



Project \_\_\_\_\_  
 Item # \_\_\_\_\_  
 Quantity \_\_\_\_\_

# SPECTRUM

## Commercial Electric Countertop Thermal Circulator

Model: ESVC-28

Get sous vide cooking with the SPECTRUM THERMAL CIRCULATOR. With precise temperature control and by reducing heat fluctuations, food retains moisture, nutrition, and flavor for perfect results every time.

### Standard Features

- ◆ All stainless steel construction
- ◆ Easy to use solid state digital control panel
- ◆ Wire clip on side conveniently holds lid when open
- ◆ Built-in drain valve for easy water removal
- ◆ Includes sectioned removable lifting rack to cook multiple vacuum-sealed portions
- ◆ Precise temperature accuracy: +1°F (0.5°C)
- ◆ Maximum volume capacity: 7.4 gallons (28L)
- ◆ Temperature range: 41°F to 210°F (5°-99°C)
- ◆ Timer setting range: 5 minutes – 99 hours
- ◆ LED display: Optional °F / °C, with last temperature and time memory when turned on
- ◆ One year parts and labor warranty



ESVC-28



### Parts

ESVC-P2	Control Board
ESVC-P4	Fan
ESVC-P11	Filter Screen
ESVC-P13	Baffle Handle
ESVC-P14	Baffle
ESVC-P15	Steel Frame
ESVC-P16	Tank Cover
ESVC-P17	NEMA 5-20P Cord/Plug (Canada)
ESVC-P18	Handle Pipe

### Options & Accessories

ESV-BH	Stainless Steel 3-Ring Bag Holder Stand
ESV-IB	Sous Vide Insulation Balls
EVPM-12	Chamber Vacuum Packaging Machine
NSP-10W	10" High Heat Nylon Mixing Paddle (400°F & BPA Free)
NS-12	12" High Heat Nylon Spoon (400°F & BPA Free)



ESV-BH



ESV-IB

### For California Customers

**WARNING:** Cancer and Reproductive Harm - [www.P65Warnings.ca.gov](http://www.P65Warnings.ca.gov)

Winco®

[www.wincous.com](http://www.wincous.com) | [equipsales@wincous.com](mailto:equipsales@wincous.com)

**New Jersey Headquarters:**  
 65 Industrial Road, Lodi, NJ 07644  
 Tel. 1.888.946.2682 | Fax: 1.888.946.2632

**California Distribution Center**  
 14950-14952 Valley View Avenue, La Mirada, CA 90638  
 Tel. 1.888.946.2652 | Fax: 1.562.926.5678

**Florida Distribution Center**  
 10800 NW 103rd St. Bldg 22, Ste 11, Miami, FL 33178  
 Tel. 1.786.536.4656



**Commercial Electric  
Countertop Thermal Circulator**  
Model: ESVC-28

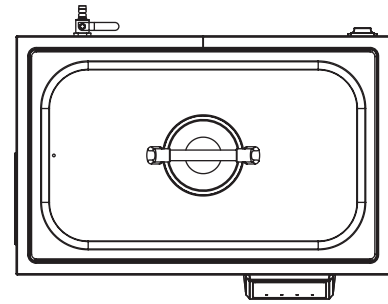

TOP VIEW

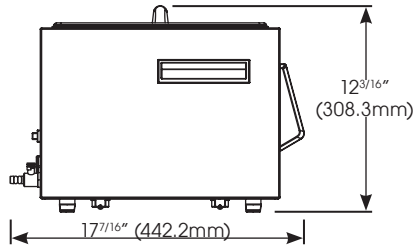

SIDE VIEW

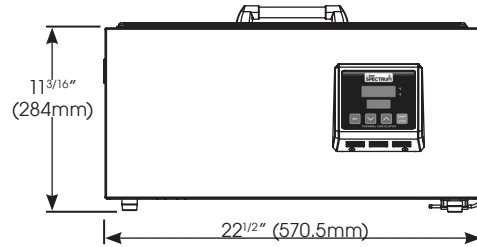

FRONT VIEW

**Specifications**

MODEL	DESCRIPTION	OVERALL DIMENSIONS			VOLTS	HZ	WATTS	AMPS	PLUG	SHIP WEIGHT
		LENGTH	DEPTH	HEIGHT						
ESVC-28	Thermal Circulator	22-1/2" (570.5mm)	17-7/16" (442.2mm)	12-3/16" (308.3mm)	110-120	60	1800	15	NEMA 5-15P	18.74 lbs (8.5 kgs)

**Cord Location**

On back right side

**Plug Configuration**

NEMA 5-15P

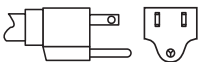

NOTE: Optional NEMA 5-20P plug available for Canada – #ESVC-P17 (sold separately)

**Product Specs**

**Spectrum Commercial Electric Thermal Circulator**

The Commercial Electric Countertop Thermal Circulator model ESVC-28 as manufactured by Winco®, Lodi, NJ 07644.

The Commercial Electric Thermal Circulator shall be rated at 1800 Watts, 120V-60Hz.

ESVC-28 shall be used with a maximum volume capacity of 7.4 gallons (28L). Wire clip on the side conveniently holds lid when open. Built-in faucet and drain allow easy water removal. Sectioned tray included to cook multiple vacuum-sealed portions. Controls and display have precise temperature accuracy of +1°F (0.5°C). Temperature range of 41°F to 210°F (5°C to 99°C). Timer setting range of 5 minutes to 99 hours, and LED display with optional °F / °C, with last temperature and time memory when turned on.

The optional stainless steel 3-Ring Bag Holder Stand (ESV-BH) conveniently holds various sizes of vacuum-packing bags open for easy filling.

The optional Insulation Balls (ESV-IB) add insulation to any open cooking bath, effectively reducing heat loss and evaporation.

ETL listed for safety (Canada & US) and sanitation.

Warranty consists of one year parts and labor.

**Winco®**

www.winco.us.com | equipsales@winco.us.com

**New Jersey Headquarters:**  
65 Industrial Road, Lodi, NJ 07644  
Tel. 1.888.946.2682 | Fax: 1.888.946.2632

**California Distribution Center**  
14950-14952 Valley View Avenue, La Mirada, CA 90638  
Tel. 1.888.946.2652 | Fax: 1.562.926.5678

**Florida Distribution Center**  
10800 NW 103rd St. Bldg 22, Ste 11, Miami, FL 33178  
Tel. 1.786.536.4656