



TSP-SG0003RD 50" HEXAGONAL FITNESS TRAMPOLINE W/ HANDLE BAR



! WARNING

- YOU MUST THOROUGHLY READ AND UNDERSTAND THE INSTRUCTIONS IN THIS MANUAL, BEFORE ASSEMBLING AND USING THIS TRAMPOLINE.
- SAVE THIS MANUAL FOR FUTURE REFERENCE.
- MAXIMUM WEIGHT OF THE USER SHALL NOT EXCEED 286LBS (130KG).
- DO NOT ALLOW MORE THAN ONE PERSON ON THE TRAMPOLINE AT A TIME.
- DO NOT ALLOW YOUNG CHILDREN TO USE UNLESS SUPERVISED BY AN ADULT.

! WARNING

CHOKING HAZARD - Small Parts
Not for children under 3 years
The product is to be assembled
by an adult.

Global Customer Service

USA / CA — ✉ support@teamson.com

+1(770) 246-4898

Mon - Fri 9 AM - 4 PM EST



EU / UK — ✉ support@teamson.co.uk

+44(0)1952-916-050

Mon - Thur 9 AM - 5 PM GMT

Fri 9 AM - 4 PM GMT



ASIA — 深圳办公室：

✉ sales_ec@teamson.com

+86(0755)8885-3558.分机号108

Mon - Sat 9 AM - 5 PM GMT+8

台北辦公室：

✉ support@teamson.com.tw

+886(2)2556-6268

Mon - Fri 9 AM - 5 PM GMT+8



AU — ✉ support@teamson.com.au

ENGLISH WARNING! Not suitable for children under 3 years, as there is a choking hazard from swallowable small parts. Assembly should be carried out by an adult. Prior to assembly this package contains sharp edges and sharp points. Keep away from children until assembled. Please remove all packaging attachments before giving this item to your child. Please keep this information for possible future correspondence.

ČESKY UPOZORNĚNÍ! Výrobek není vhodný pro děti do 3 let. Obsahuje drobné části, hrozí nebezpečí udušení. Montáž musí provádět dospělý. Design a barvy výrobků mohou být změněny bez předchozího upozornění. Před prvním použitím odstraňte všechny obaly z dosahu dětí. Tyto informace uschovejte pro případné budoucí použití.

CROATIA UPOZORENJE! Igračka nije prikladna za djecu mlađu od tri godine zbog malih dijelova gušenja opasnost. Skupština mora biti izvedena od strane odrasle osobe. Varijacije u boji i dizajnu, mi se pridržavamo. Uklonite sve ambalaze prije prve uporabe. Sačuvajte ove informacije za bilo koji naknadno dopisivanje.

DUTCH WAARSCHUWING! Niet geschikt voor kinderen beneden 3 jaar omdat er gevaar voor verstikking door inslikbare kleine voorwerpen bestaat. De montage van dit speelgoed moet door een volwassene worden uitgevoerd. Kleuren en versieringen kunnen afwijken. Verwijder alle verpakkingselementen voordat u dit speelgoed aan uw kind geeft. Bewaar deze verpakking voor een eventuele latere correspondentie.

FRENCH ATTENTION! Ce produit est inadapté aux enfants de moins de 3 ans, car il existe le risque d'étouffement causé par les petites pièces qui peuvent s'avaler. Le montage doit être effectué par un adulte. Nous nous réservons le droit d'apporter des modifications aux couleurs et à la conception. Retirer l'emballage et les attaches plastiques avant de donner cet article à votre enfant. Nous vous prions de conserver cette information pour une éventuelle utilisation ultérieure.

GERMAN ACHTUNG! Nicht geeignet für Kinder unter 3 Jahren, da Erstickungsgefahr durch verschluckbare Kleinteile besteht. Der Zusammenbau muss von einem Erwachsenen durchgeführt werden. Abweichungen in Farbe und Gestaltung behalten wir uns vor. Bitte entfernen Sie alle Verpackungsteile vor dem erstmaligen Gebrauch. Bitte bewahren Sie diese Information für evtl. spätere Korrespondenz auf.

HUNGARY FIGYELMEZTETÉS! Nem alkalmas 3 év alatti gyermekek, mert a kis alkatrészek fulladást okozhatnak. A szerkezetet úgy kell elvégezni egy felnőtt. Szín és design fenntartva. Kérjük, távolítsa el a csomagolást az első használat előtt. Kérjük, őrizze meg ezt az információt bármilyen későbbi vonatkozó levelezést.

ITALIAN AVVERTENZA! Non adatto a bambini al di sotto dei 3 anni, visto che vi è rischio di asfissamento causato dall'ingerimento di componenti piccoli. Il montaggio di questo prodotto deve essere fatto sotto di un adulto. I colori e le decorazioni possono variare. Per favore conservare la confezione nel caso ci sia bisogno di spedire indietro qualcosa.

POLSKI OSTRZEŻENIE! Produkt nie nadaje się dla dzieci poniżej 3-go roku życia. Ze względu na małe części istnieje ryzyko zadławienia, poknięcia, itd. Montaż wózka powinien odbywać się pod nadzorem osoby dorosłej. Przed pierwszym użyciem proszę usunąć wszystkie elementy opakowania. Kolory i wzory mogą się różnić. Należy zachować opakowanie w przypadku konieczności wymiany.

PORTUGAL AVISOS! Guarde esta informação para futura referência. Não apropriado para crianças com menos de 3 anos de idade devido à existência de peças pequenas e bordas/pontas afiadas. Este brinquedo deve ser montado por um adulto. As cores e o conteúdo podem ser algo diferentes do mostrado na caixa. Retire todo elemento de embalagem antes de entregar o produto à criança.

SLOVENIJA OPOZORILO! Ni primerno za otroke mlajše od treh let. Nevarnost zadušitve. Majhni deli. Sestav mora opraviti odrasla oseba. Razlike v barvo in obliko, si pridržujemo pravico do. Prosimo, odstranite vse pakirni material pred prvo uporabo. Prosimo, da shranite te informacije za vsak nadaljnji korespondenci.

SLOVENSKY UPOZORNENIE! Výrobok nie je vhodný pre deti do 3 rokov. Obsahuje drobné časti, hrozí nebezpečenstvo udusenía. Montáž musí vykonávať dospelý. Design a farby výrobkov môžu byť zmenené bez predchádzajúceho upozornenia. Pred prvým použitím odstráňte všetky obaly z dosahu detí. Tieto informácie uschovejte pre prípadné budúce použitie.

SPAIN ADVERTENCIA! Guarde esta información para futura referencia. No apto para niños menores de 3 años por contener piezas pequeñas, contiene bordes/puntas afiladas. Este juguete debe ser montado por un adulto. Los colores y el contenido pueden ser algo diferentes de lo mostrado en la caja. Retire todos los elementos de embalaje antes de dar el artículo a su hijo.

SVENSKA VARNING! Inte lämplig för barn under 3 år på grund av små delar kvävningrisk. Monteringen måste utföras av en vuxen. Färg och design är reserverade. Ta bort allt förpackningsmaterial före första användningen. Vänligen behålla denna information för eventuell senare korrespondens på.

繁體 警告! 需由成年人完成組裝。本產品不適於3歲以下兒童使用。本包裝包含細小零件，完成組裝前，請慎防兒童吞食小零件，避免窒息危險，且可能有鋒利邊緣及尖角，所以組裝完成前應置於兒童不能觸及之處，並遠離火源。

簡體 警告! 需要成年人組裝。不適合三歲以下的兒童使用。完成組裝前，本包裝包含細小零件，可能引發窒息危險；以及包含鋒利邊緣和尖角，所以完成組裝前，請確保其遠離兒童。



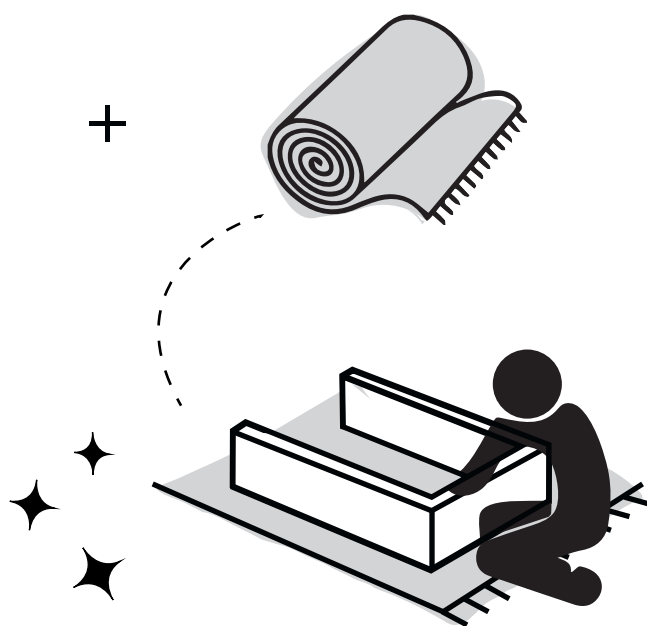
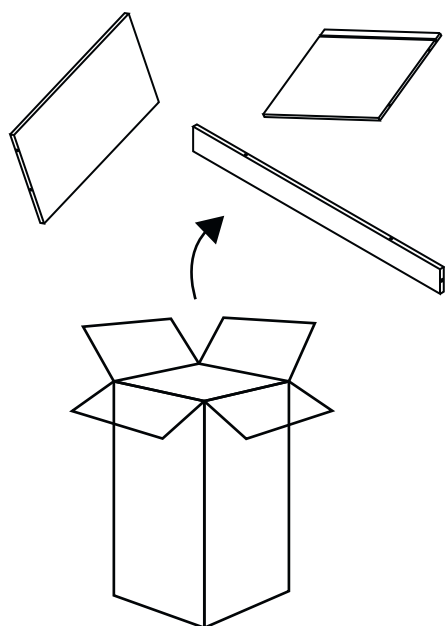
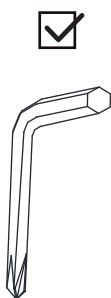

** Got questions?

Please have your product code (on the first page of this instruction, e.g. TSP-SG0003RD) and the order number ready, give us a call or email us through our customer care support!

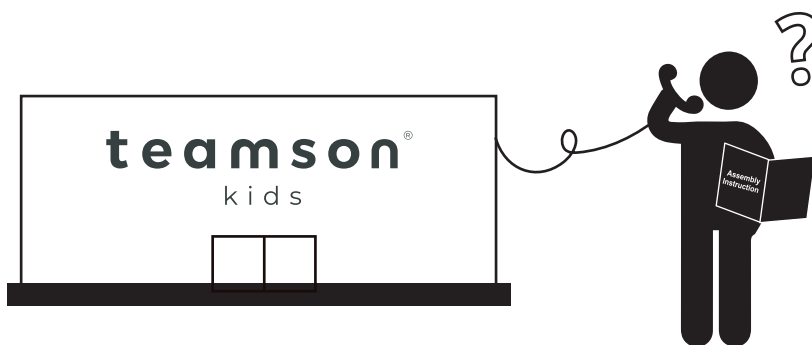

We are always ready to assist you!

CARE INSTRUCTIONS

To clean your product, use mild soap and water on a damp cloth, Do not use window cleaners or cleaning abrasives as they will scratch the surface and could damage the protective coating.

Important Safety Information

Please keep this manual in a safe place for reference.

1. It is important to read this entire manual before assembling and using the equipment. Safe and efficient use can only be achieved if the equipment is assembled, maintained and used properly. It is your responsibility to ensure that all users of the equipment are informed of all warnings and precautions.
2. Use the equipment on a solid, flat level surface with a protective cover for your floor or carpet.
3. The safety level of the equipment can only be maintained if it is regularly examined for damage and/or wear and tear. Special attention to components most susceptible to wear (e.g. mat, padding and its attachment, tension and its mounts, anti-slip or connection points).
4. Always use the equipment as indicated. If you find any defective components whilst assembling or checking the equipment, or if you hear any unusual noise coming from the equipment during use, stop. Do not use the equipment until the problem has been rectified. Defective parts are to be replaced in accordance with the manufacturer's instructions.
5. Wear suitable clothing whilst using the equipment. Avoid wearing loose clothing which may get caught in the equipment or that may restrict or prevent movement.
6. The equipment is not suitable for therapeutic use.
7. Care must be taken when lifting or moving the equipment so as not to injure your back. Always use proper lifting techniques and/or use assistance.
8. Warning. Only for domestic use and indoor use.
9. Warning. Not suitable for children under 3 years. Small parts. Choking hazard.
10. Warning. Maximum weight of user: 286lbs/130kg.
11. Warning. Only one user. Collision hazard.
12. Warning. Practice with shoes.
13. Warning. Do not use the mat when it is wet.
14. Warning. Empty pockets and hands before practice.
15. Always jump in the middle of the mat.
16. Warning. Do not eat while jumping.
17. Warning. Do not exit by a jump.
18. Limit the time of continuous usage. Make regular stops. Do not jump when tired.
19. Trampolines shall neither be installed over concrete, asphalt or any other hard surface nor at proximity of other conflicting installations (e.g. paddling pools, swings, slides, climbing frames).
20. Adult supervision required.
21. No somersaults.
22. This product is not suitable for persons under 14 years!
23. When using the trampoline, always keep your body weight centered. Do NOT lean your entire body weight on the handlebar in order to avoid flipping or tipping over.

IMPORTANT!

READ IT! Failure to follow these instructions to ensure proper operational condition of your trampoline may lead to serious injury or death. Do not allow more than one person on the trampoline at a time.

● Maintenance instruction:

Shall carry out checks and maintenance of the main parts (frame, suspension system, mat, padding and Anti-slip) at regular intervals. If these checks are not carried out, the trampoline could become dangerous.

It is of particular importance that the following recommendations shall be followed at the beginning of each season, as well as at regular intervals during the usage season:

- Regular maintenance is required. Neglecting regular maintenance can lead to a risk for users.
- All nuts and bolts must be checked for tightness and if necessary must be retightened.
- All elastic cords and joints must be checked to see that they are still intact and cannot become dislodged during play.
- Check all coverings for bolts and sharp edges and replace them if necessary.
- Check that mat and padding are without defects and can withstand load. Environment and extreme temperatures will make these parts lose strength.

● Maintenance of Frame Pad

Frame pad is prone to wear and tear like tires on a car. Gradual deterioration of the material will occur, the speed of which will depend on the level of exposure to UV rays, airborne pollution, and outdoor weather conditions such as rain and wind.

The pad needs to be properly maintained and checked by following the Maintenance Schedule set out in these instructions. When the material shows any signs of weakness, you must stop using the trampoline immediately, properly store the trampoline and restrict access by users until a new replacement pad is properly installed.

| 1 to 3 Months | 3 to 6 Months | 6 to 12 Months |
|---|---|---|
| Thorough inspection for UV damage and prior to every use for pad. | Thorough inspection for UV damage and prior to every use for pad, net and straps. | Thorough inspection before every use. Replace after 12 months or earlier |

IT IS RECOMMENDED THAT THE PAD BE REPLACED ON A YEARLY BASIS OR EARLIER UNDER NORMAL USE, EVEN IF IT DOES NOT SHOW ANY VISIBLE SIGNS OF DAMAGE.





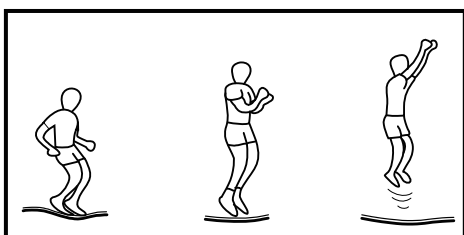





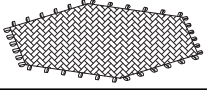
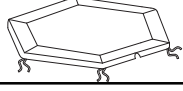

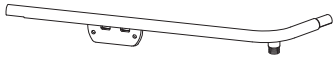

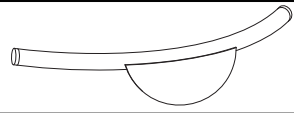
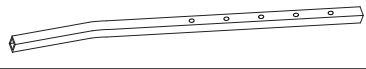
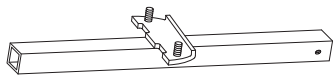

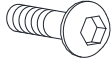
BASIC TRAMPOLINE BOUNCES

THE BASIC BOUNCE



1. Start from the standing position, with your feet having shoulder width apart and with head up and eyes on mat.
2. Swing arms forward and up in a circular motion
3. Bring feet together while in mid-air and point toes downwards.
4. Keep the feet shoulder width apart when landing on mat.

Product Parts

| Part No. | Diagram | Description | Quantity |
|----------|---|---------------------------|----------|
| 1 |  | Trampoline Mat | 1 |
| 2 |  | Frame Pad | 1 |
| 3 |  | Top Rail | 5 |
| 4 |  | Top Rail with Metal Plate | 1 |
| 5 |  | Leg with Leg Cap | 6 |
| 6 |  | T-Part with Handlebar | 1 |
| 7 |  | Upper Support Tube | 1 |
| 8 |  | Lower Support Tube | 1 |
| 9 |  | Elastic Cord | 36 |
| 10 |  | Screws | 2 |
| 11 |  | Nut | 2 |
| 12 |  | Spring Washer | 2 |
| 13 |  | Flat Washer | 2 |
| 14 |  | Screw Lock | 1 |
| 15 |  | Wrench | 1 |
| 16 |  | Allen Wrench | 1 |
| 17 |  | Elastic Cord Loading Tool | 1 |
| 18 |  | Protection Ring | 6 |
| 19 |  | Tube cap | 1 |

Assembly Instruction

STEP 1

- Two adults shall assemble the trampoline and check it before use.

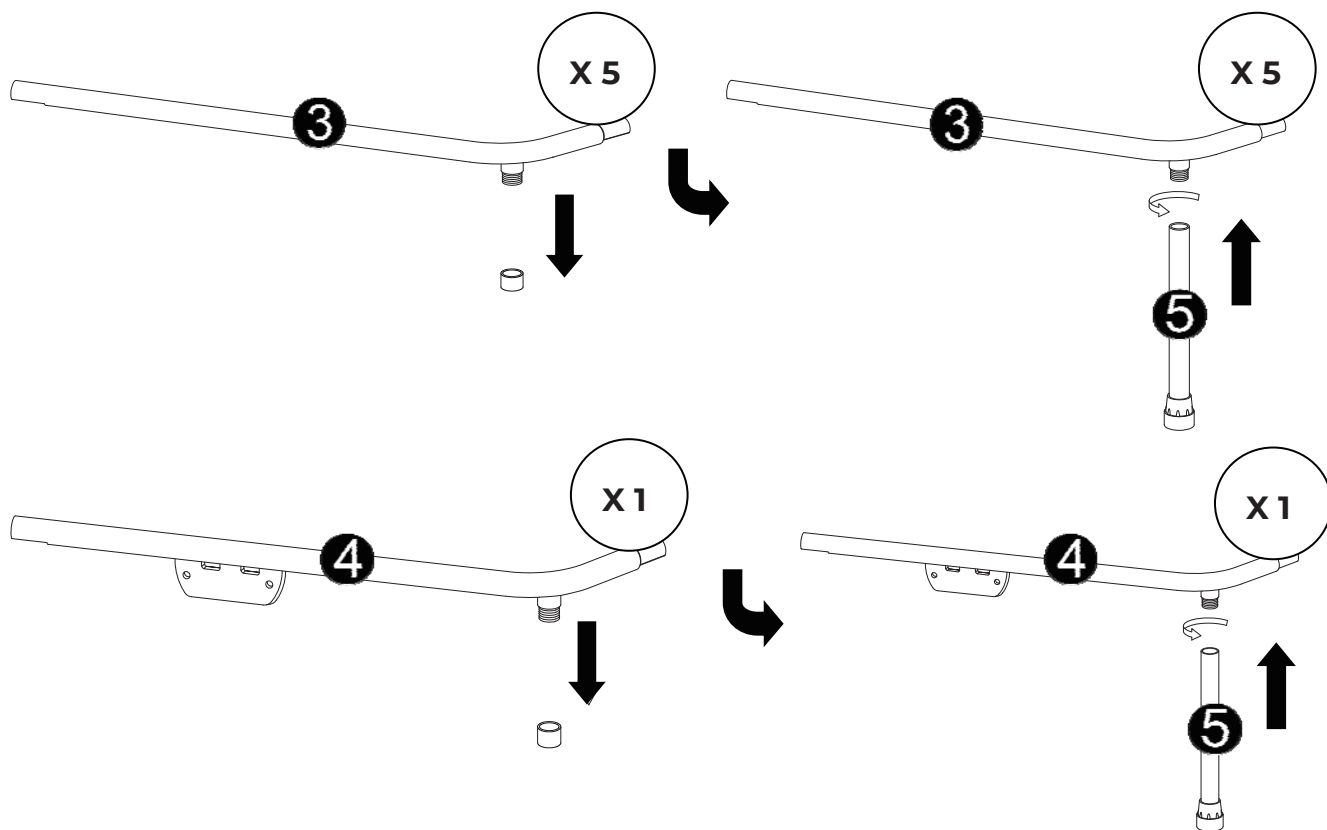

STEP 2

Slide one Protective Ring (18) on each longer arm of the Top Rails (3, 4).

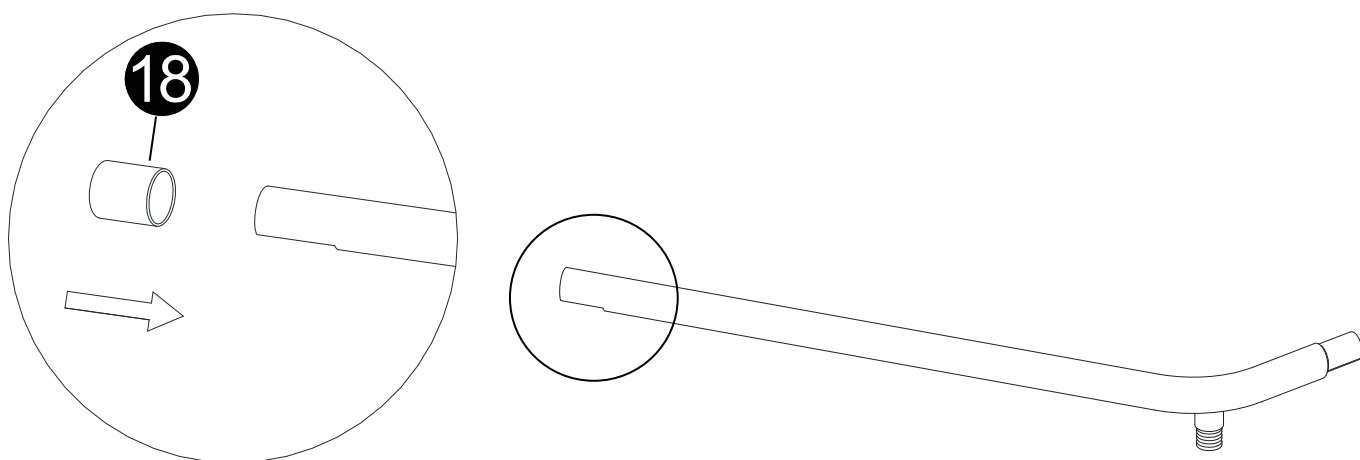

Assembly Instruction

STEP 3

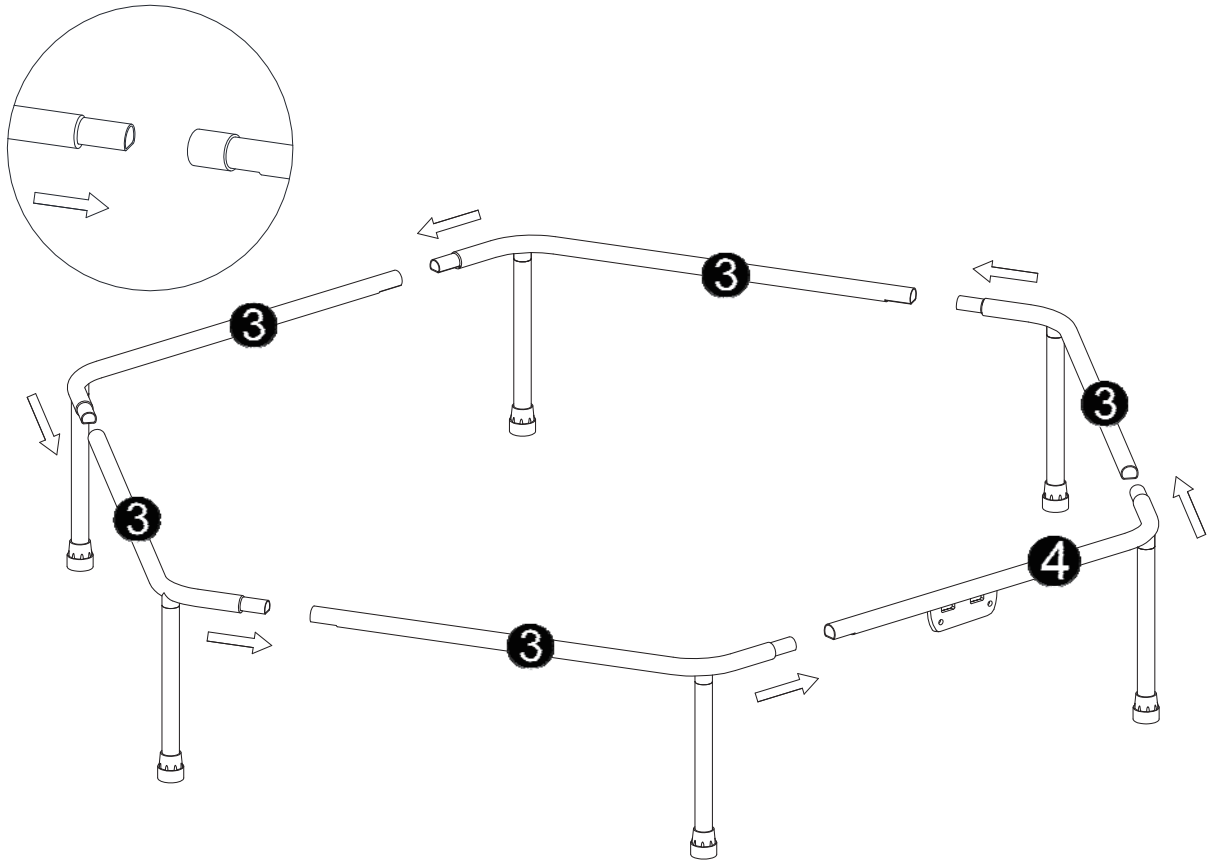

Put the 6 Top Rails (3, 4) together.

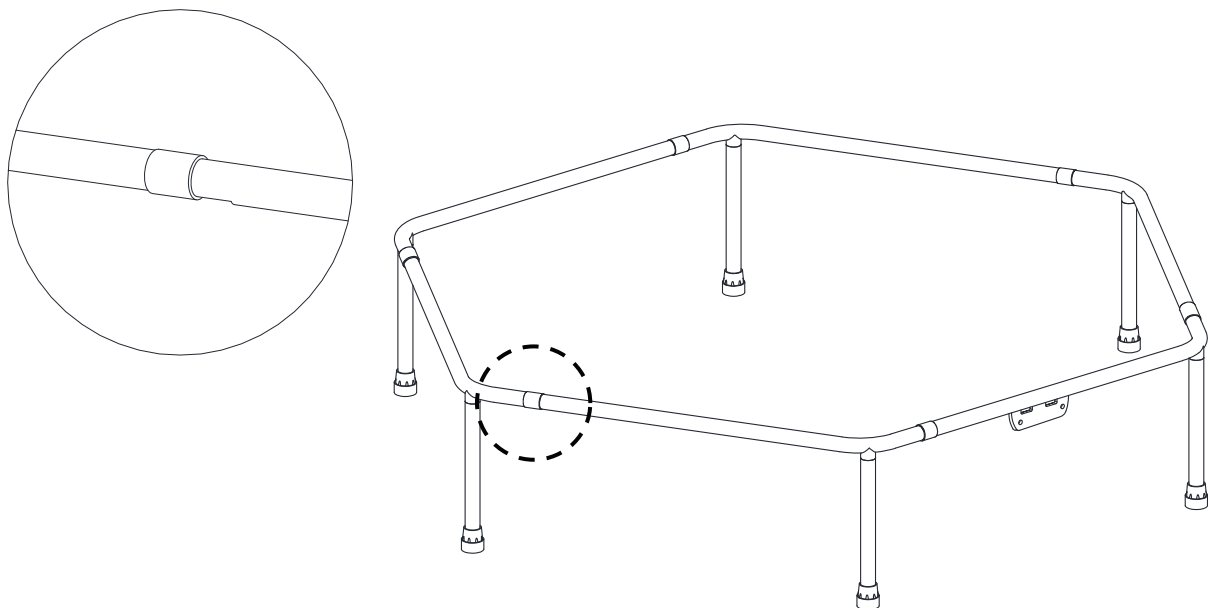

Slide the Protection Rings (18) over the contact points of the Top Rails (3, 4)

Note: The Protection Rings protect the Elastic Cords (9) from friction on the tube edges.

Assembly Instruction

STEP 4

- There is a total of 36pcs #9 Elastic cords. For even distribution of tension and ease of assembly, the Elastic cords must always be installed on opposite sides of the mat in an alternating manner.

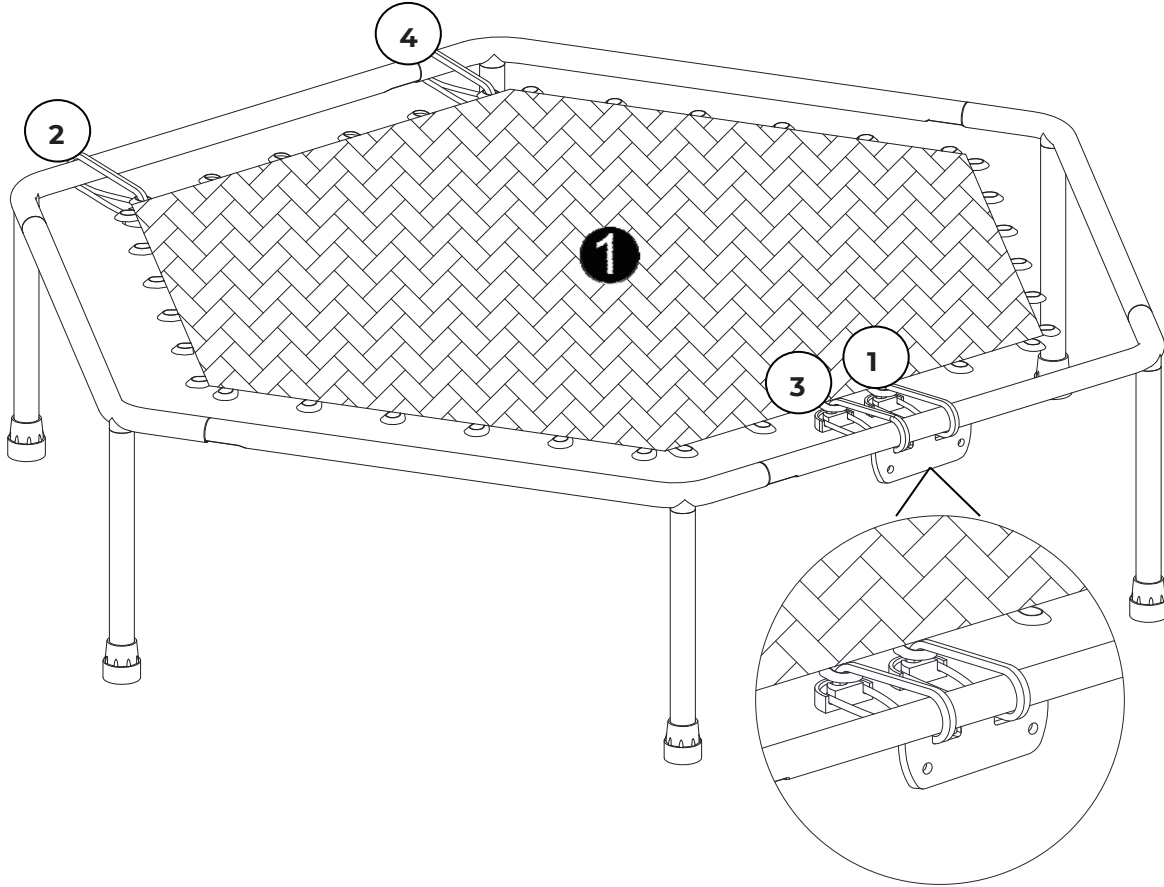

NO.1 & NO.3 : The elastic cords must be loaded through the holes on the Metal Plate

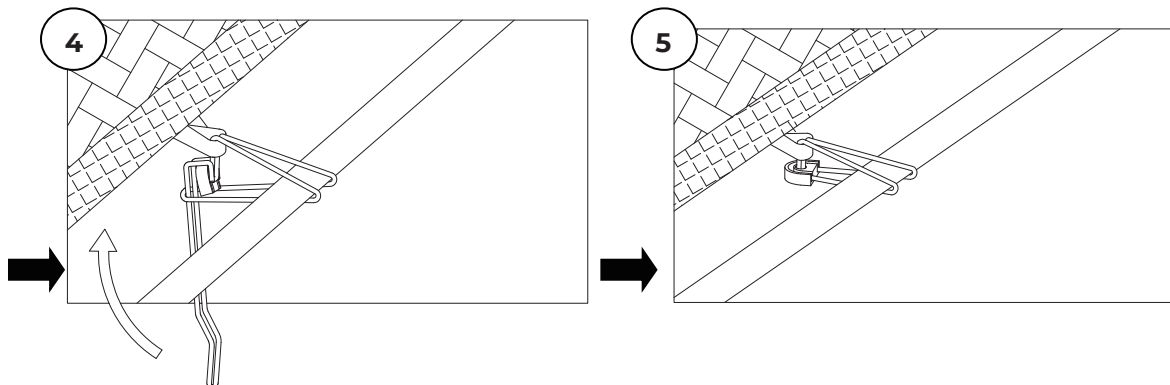
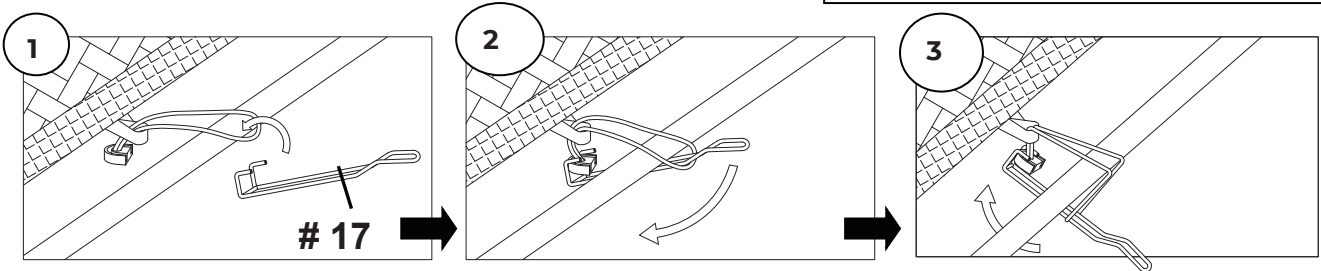

Assembly Instruction

STEP 5

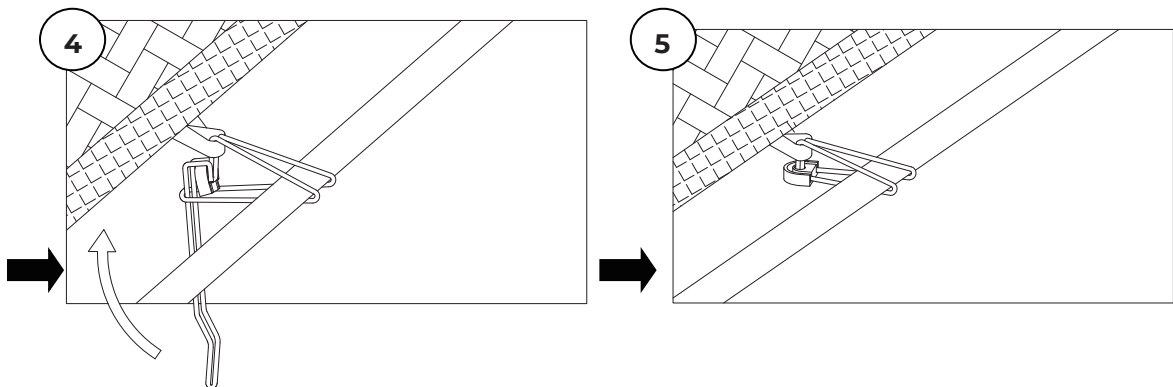
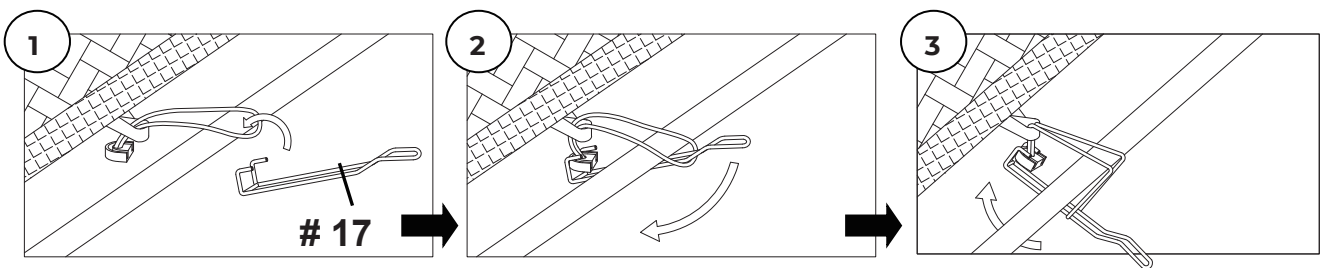
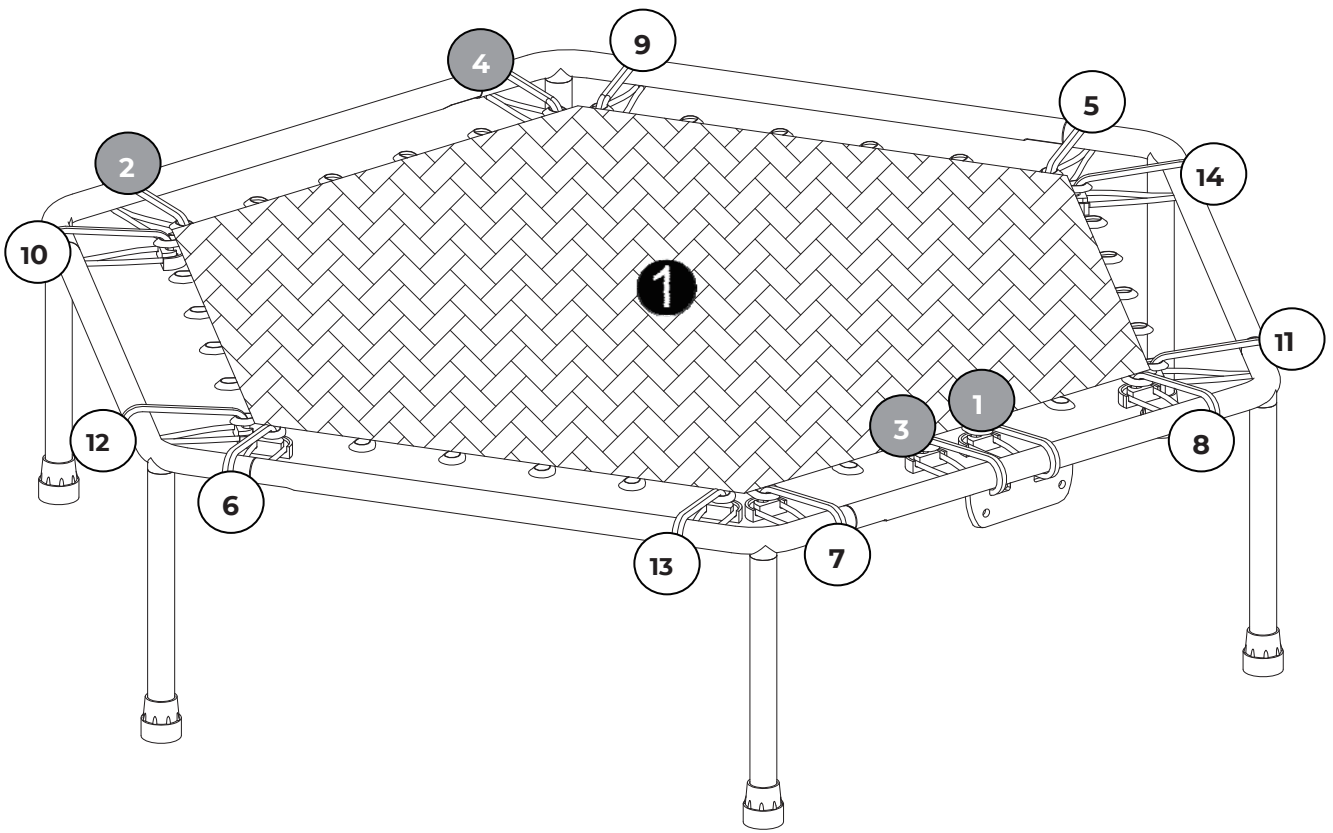

Assembly Instruction

STEP 6

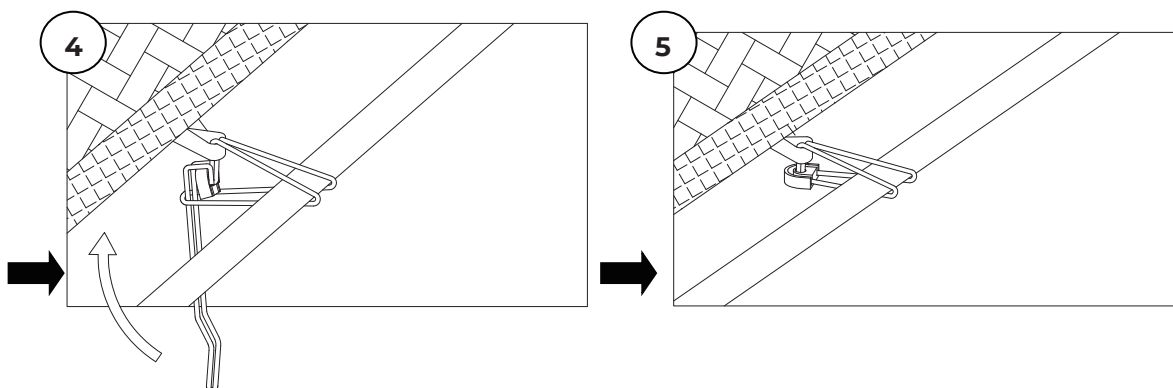
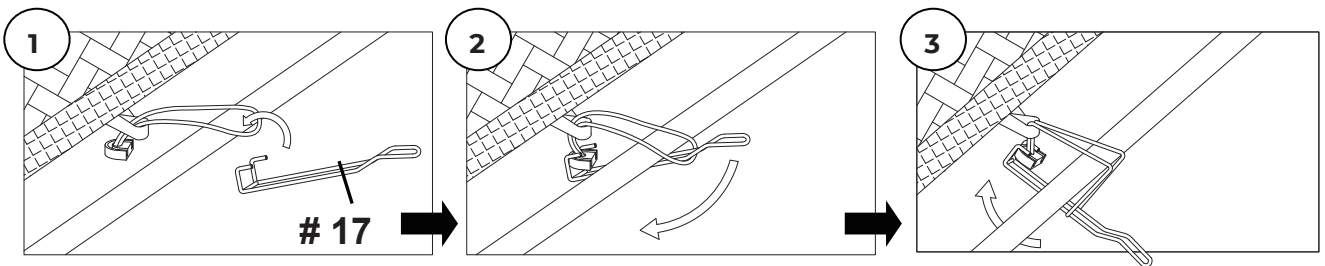
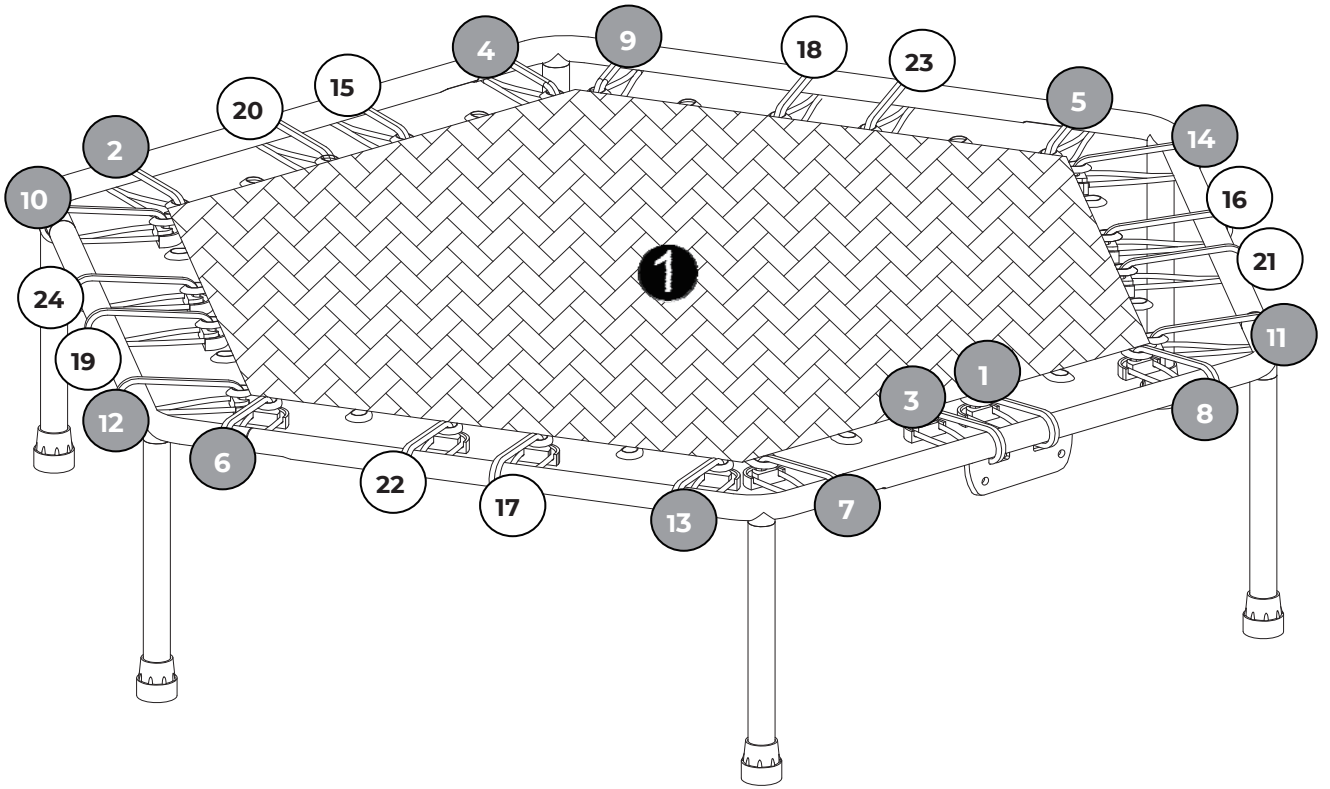

Assembly Instruction

STEP 7

- Continue to attach the remaining 12pcs of #9 Elastic cords in the same manner as the previous step.

Hint: There are 6 pieces of Elastic cords on each side of the trampoline.

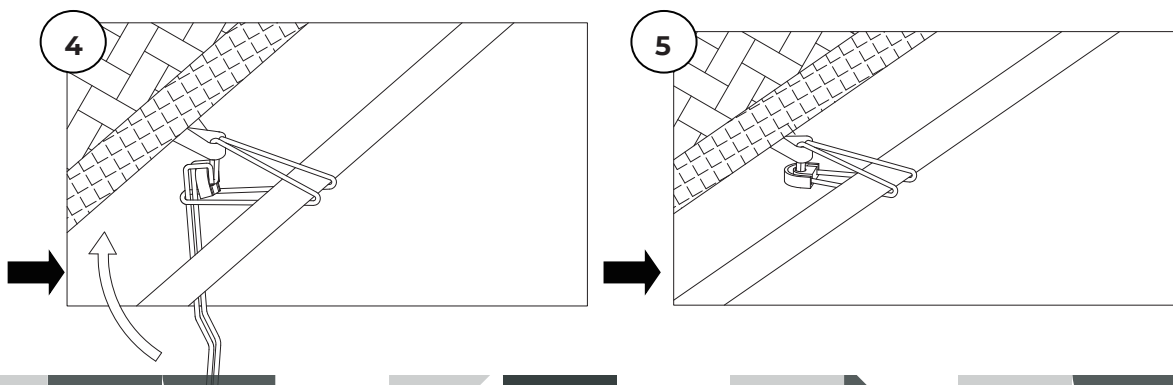
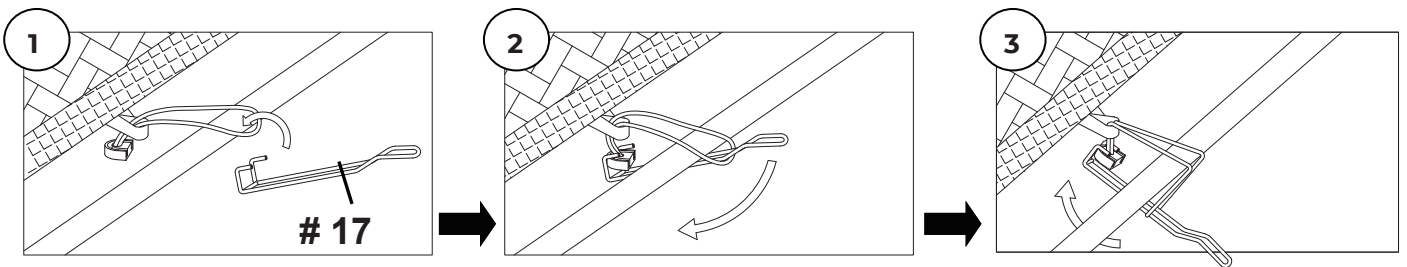
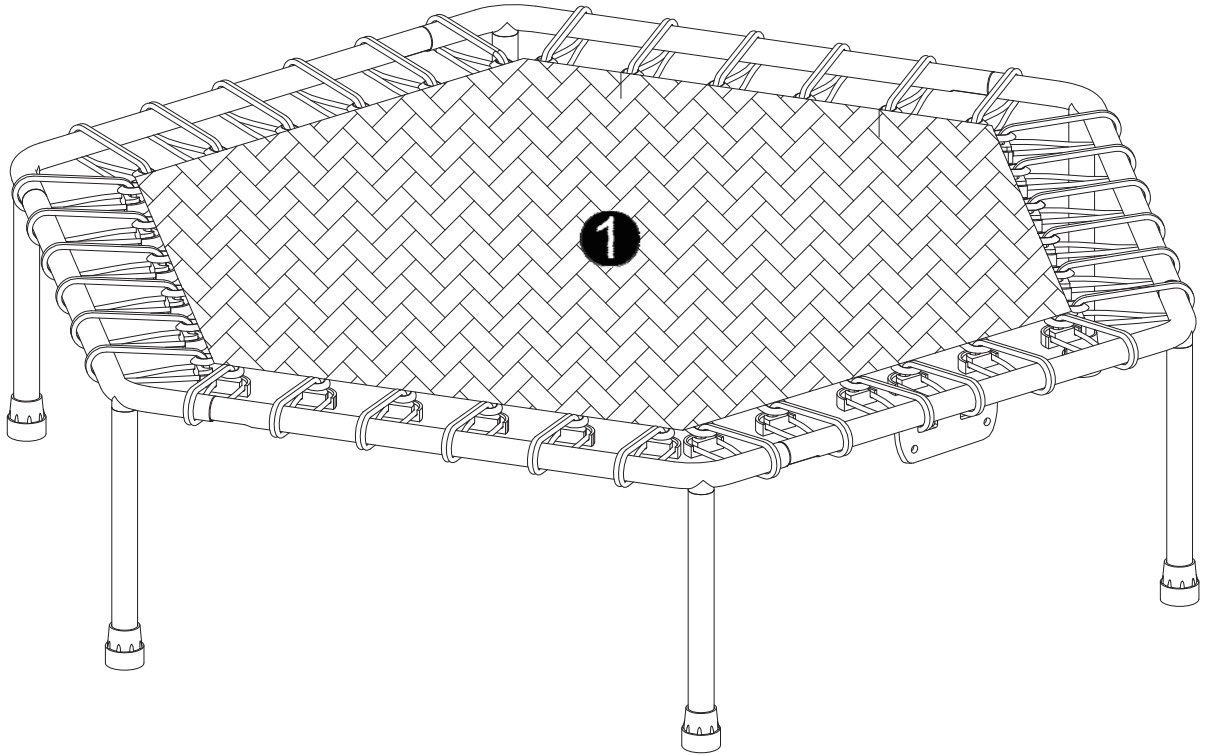

Assembly Instruction

STEP 8

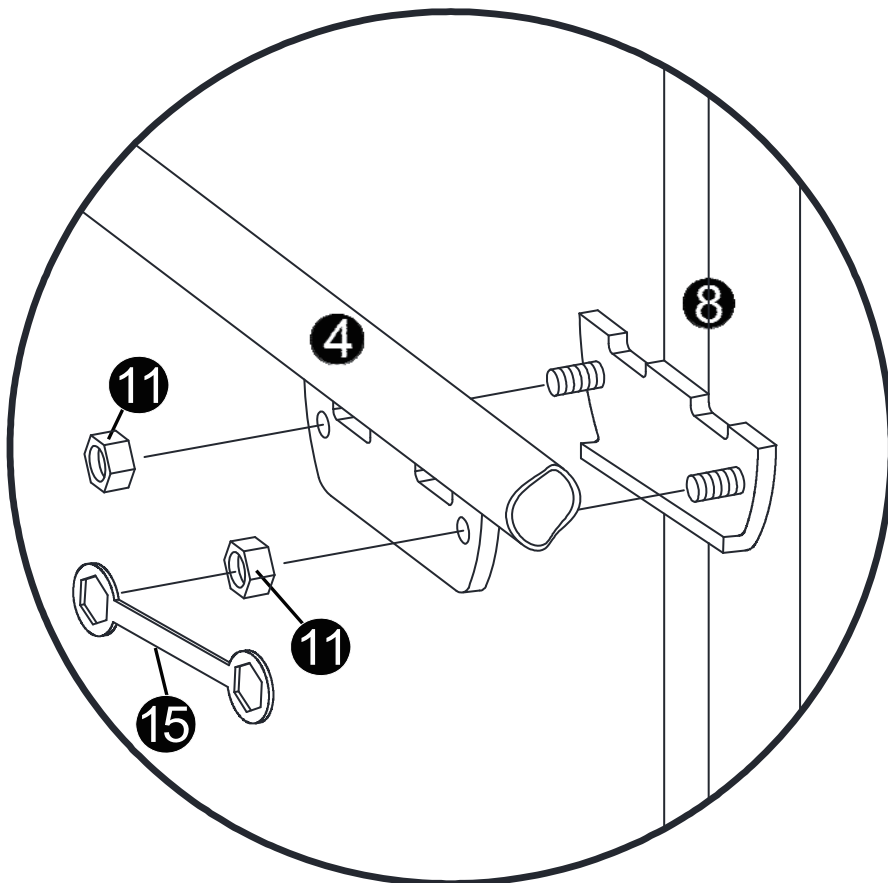
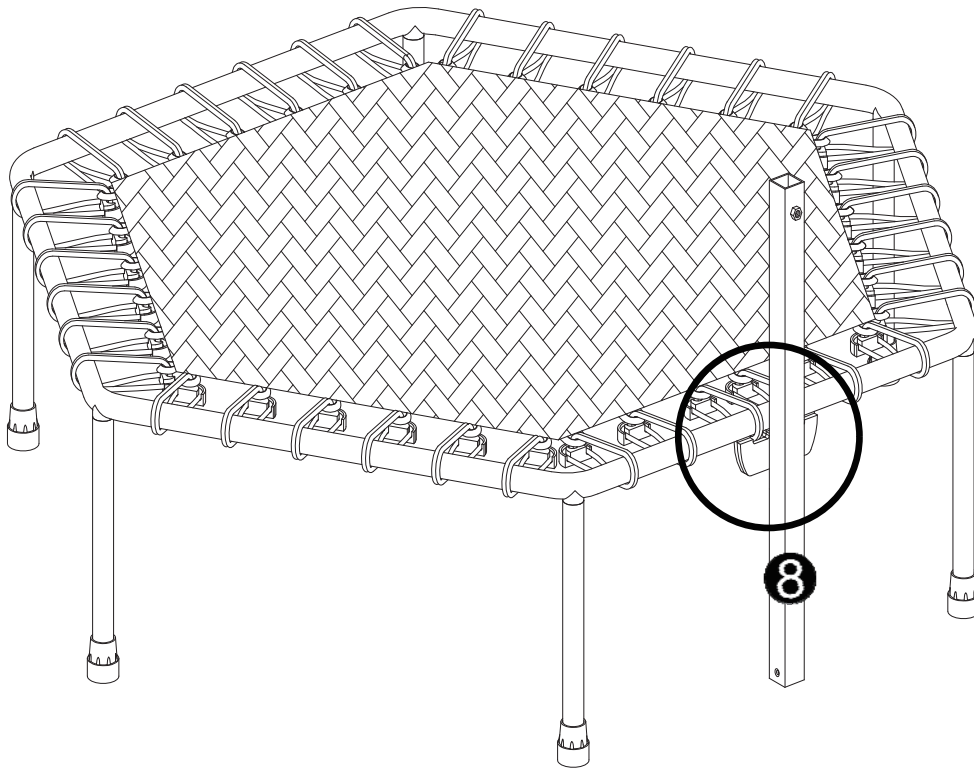

Assembly Instruction

STEP 9

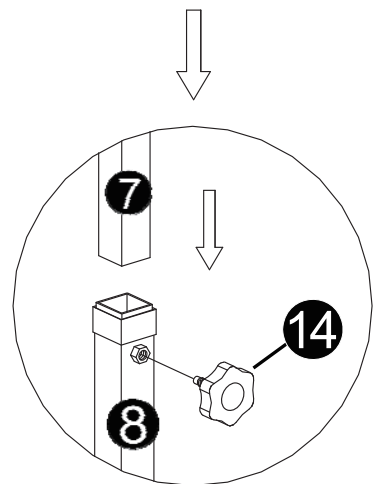
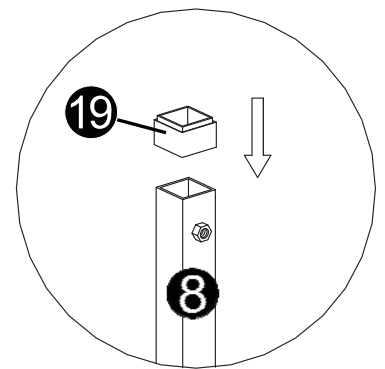
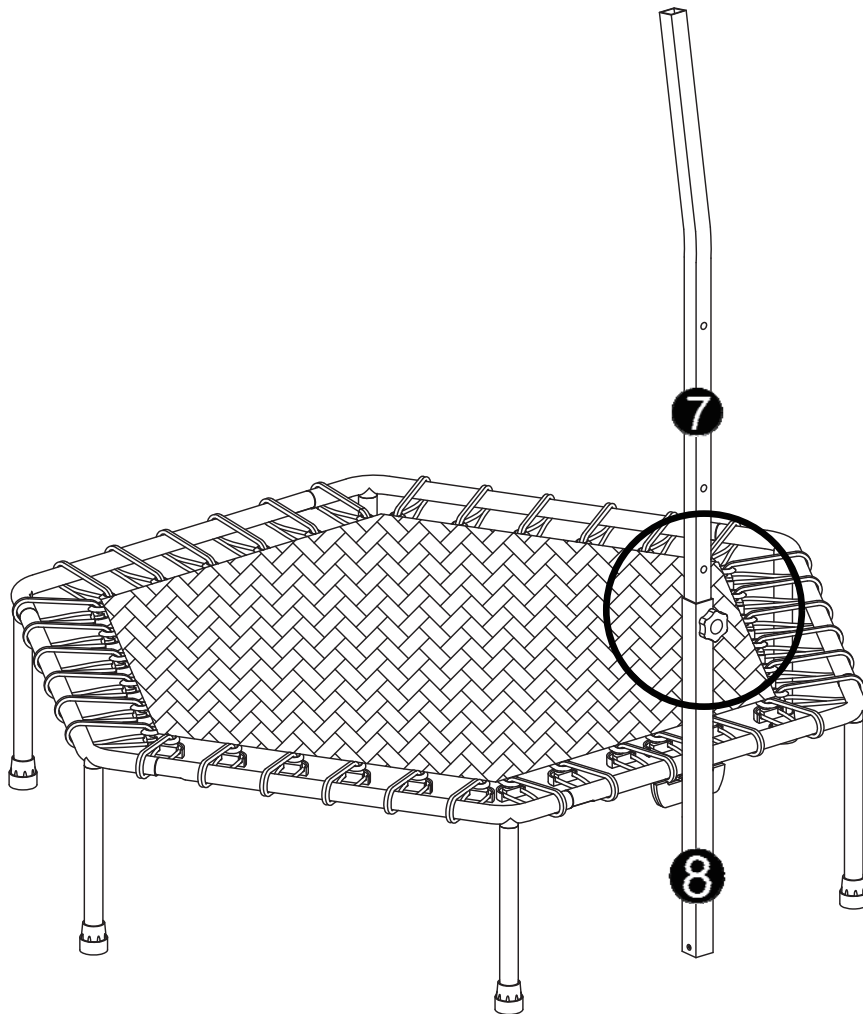

Assembly Instruction

STEP 10

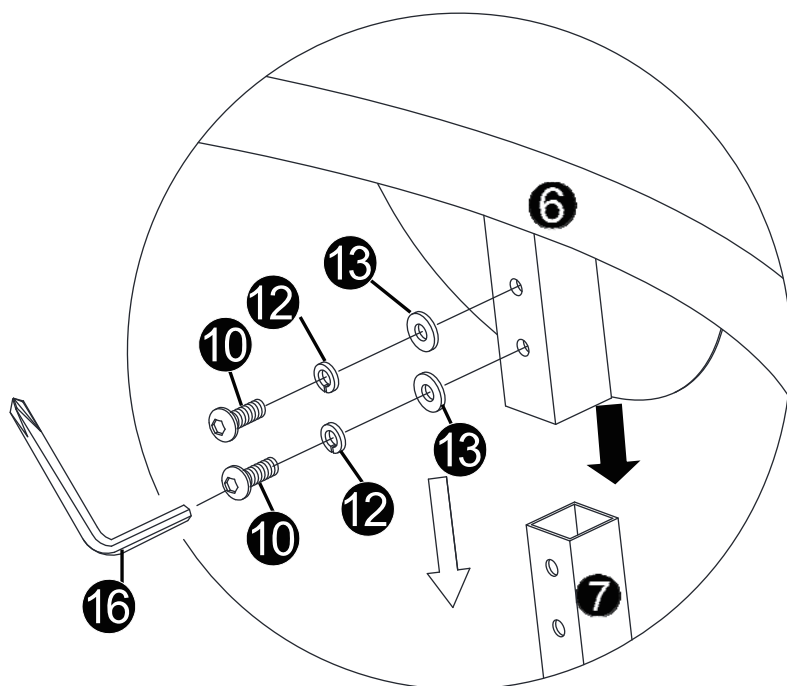
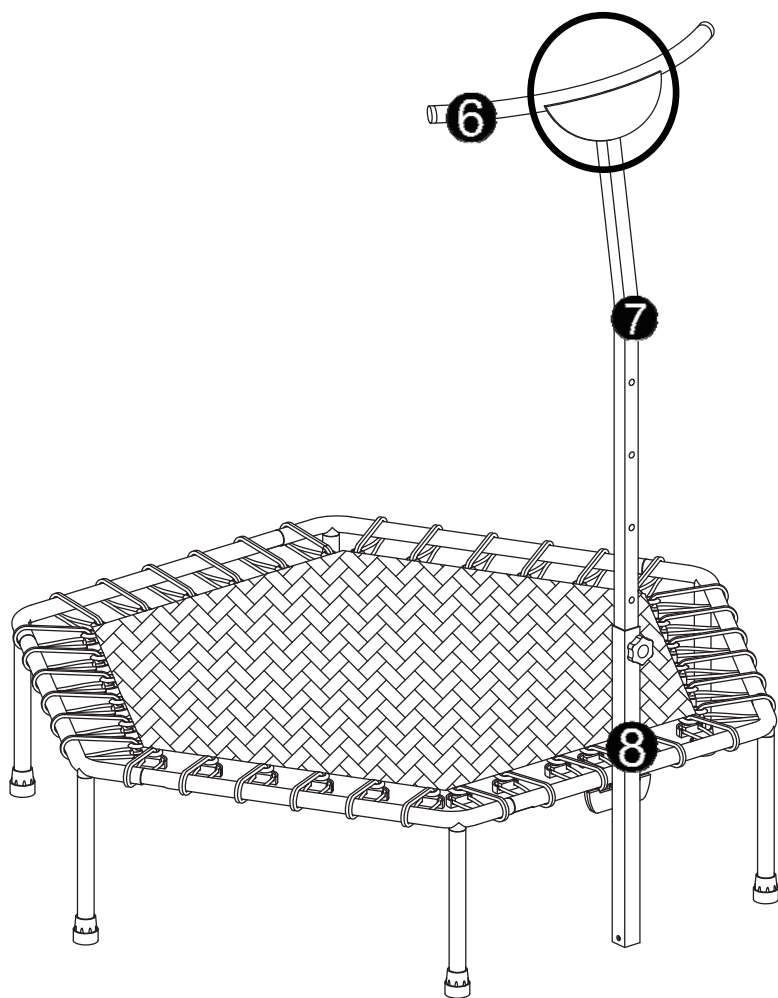

Assembly Instruction

STEP 11

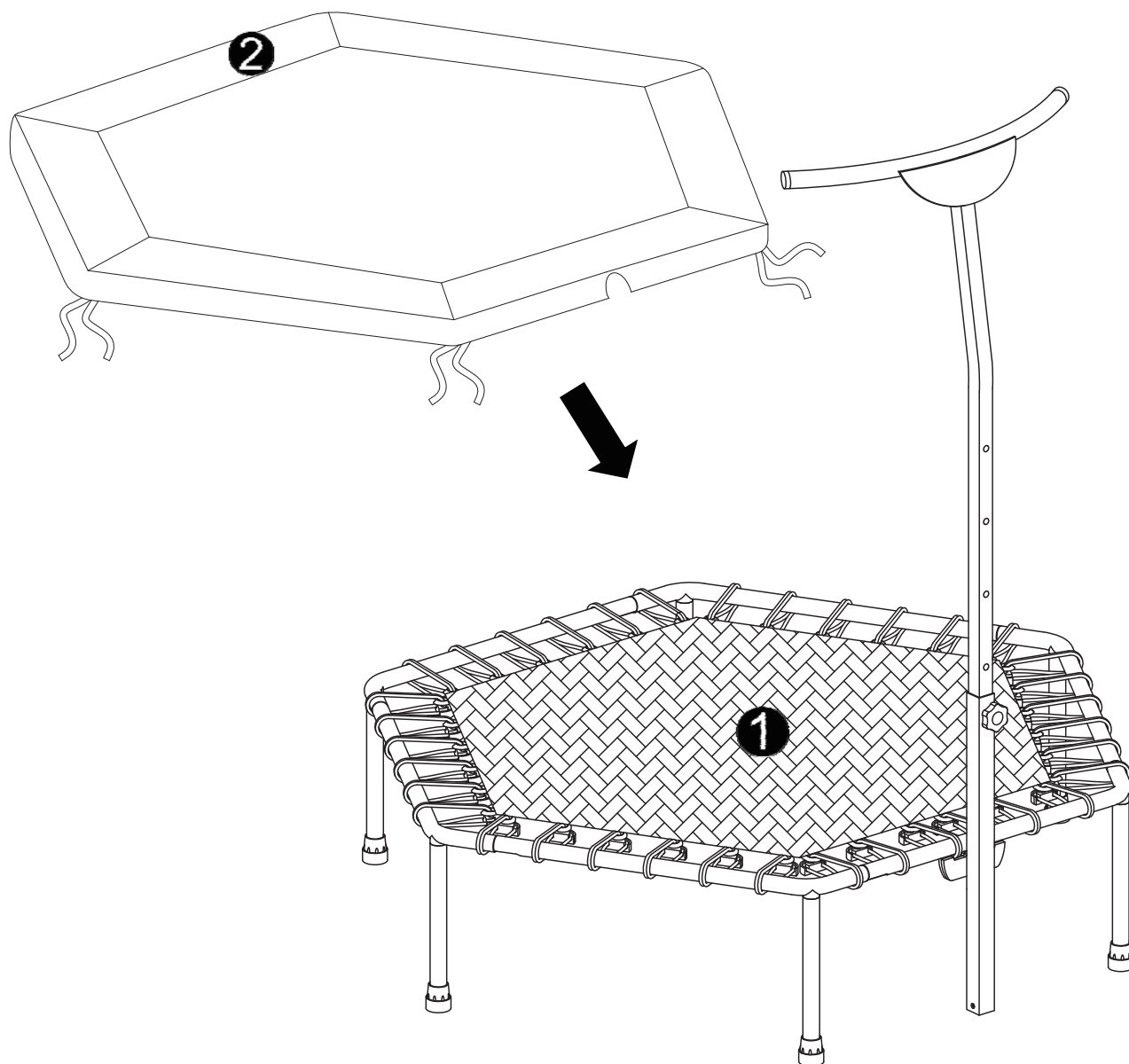

Assembly Instruction

STEP 12

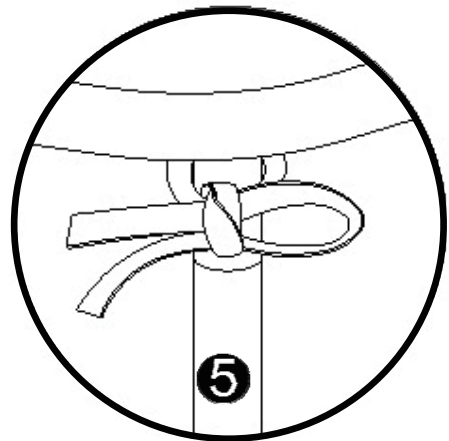
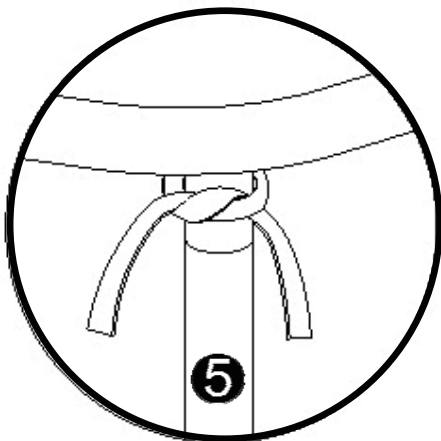
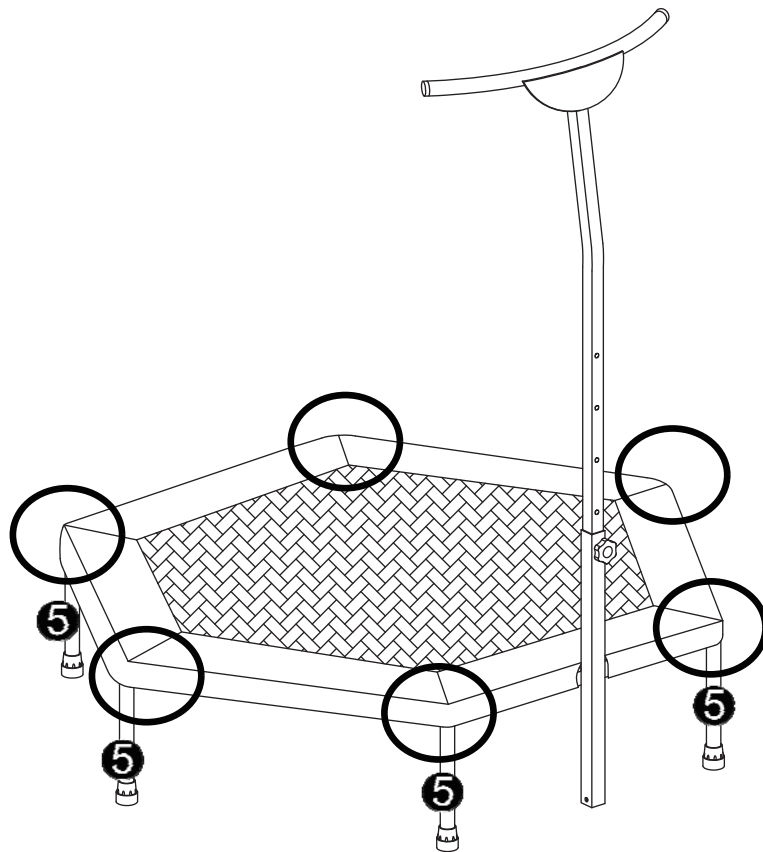

Assembly Instruction

Adjustable Handlebar

- The handlebar can be adjusted based on the user height. When adjusting the #7 Upper Support Tube, please ensure that the indented mark cannot be seen once fully assembled.

Hint: When using the trampoline, always keep your body weight centered. Do NOT lean your entire body weight on the handlebar in order to avoid flipping or tipping over.

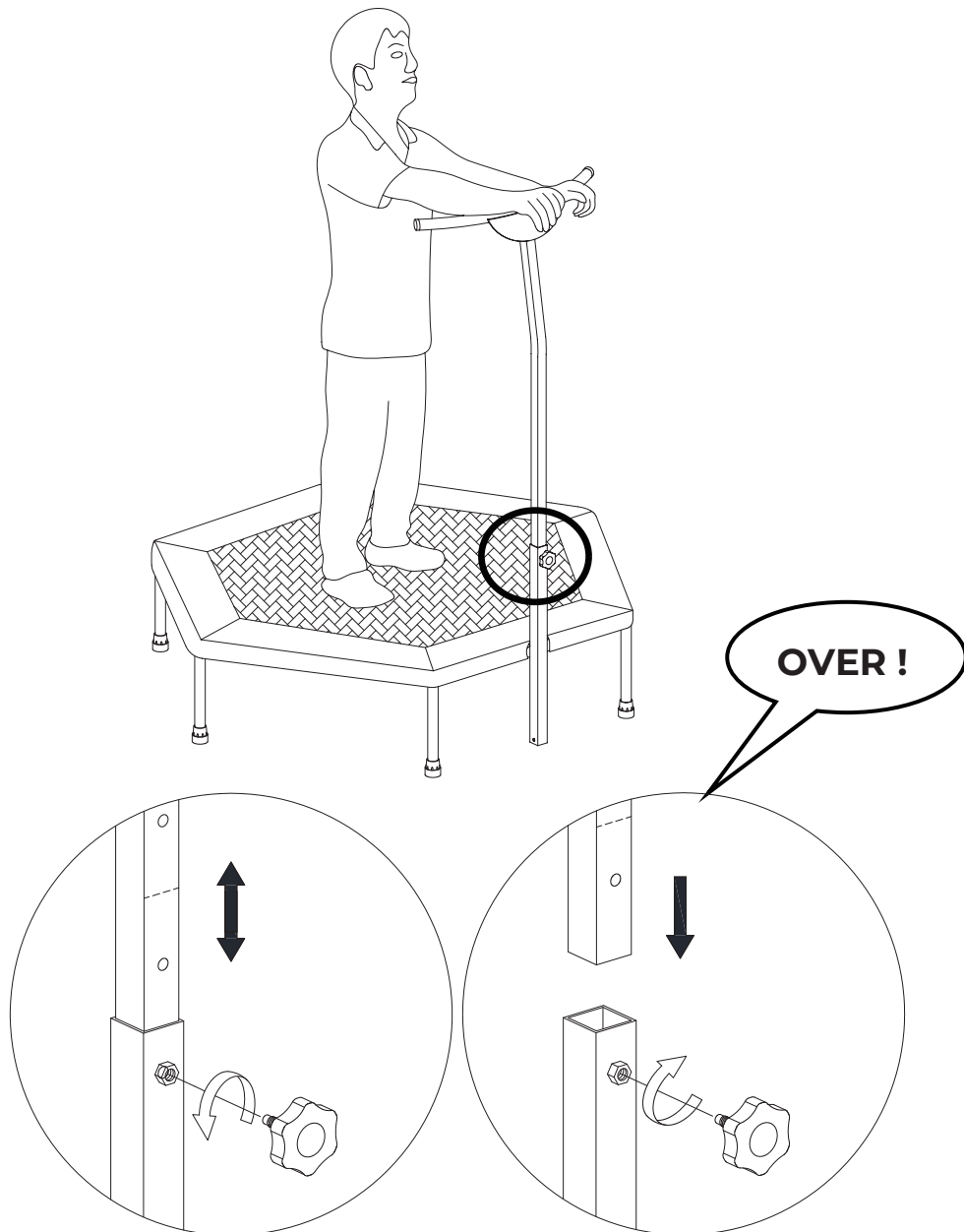

Disassembly of the Trampoline

To disassemble the trampoline, follow assembly in reverse order.

MOVING THE TRAMPOLINE

When moving, lift the trampoline slightly off the ground and keep it horizontal to the ground. For any type of other movement, you should disassemble the trampoline.