

# T8 & T12 (TYPE A+B) LINEAR LAMP

## IMPORTANT SAFETY INSTRUCTIONS AND INSTALLATION GUIDE

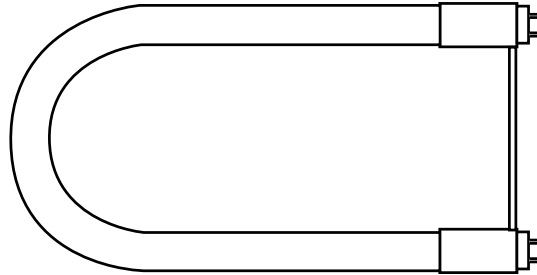

### Safety Information

**PLEASE READ THESE INSTRUCTIONS AND WARNINGS PRIOR TO INSTALLATION.  
THIS PRODUCT MUST BE INSTALLED IN ACCORDANCE WITH THE APPLICABLE INSTALLATION CODE BY A PERSON FAMILIAR WITH THE CONSTRUCTION AND OPERATION OF THE PRODUCT AND THE HAZARDS INVOLVED.**

This LED tube is intended to replace fluorescent tube lamps with ANSI designation F32T8/U with G13 base.

This product may not be compatible with all ballasts. For more information about ballast compatibility please visit [www.FEIT.COM](http://www.FEIT.COM).

1. Always follow basic safety precautions to reduce the risk of fire, electric shock and personal injury.
2. **WARNING: RISK OF FIRE OR ELECTRIC SHOCK. LED Retrofit Kit installation requires knowledge of luminaire electrical systems. If not qualified, do not attempt installation. Contact a qualified electrician.** House electric current can cause painful shock or serious injury unless handled properly. For your safety, always remember to:
  - A. **Turn OFF the power supply** at the fuse or circuit breaker box before you install the lamp.
  - B. Ensure the fixture is grounded to avoid potential electric shock and to ensure reliable starting.
  - C. Wear rubber sole shoes and work on a sturdy ladder
  - D. Do not touch with wet hands.
  - E. This lamp is not intended for use with emergency exits or emergency lights.
3. This lamp is designed for use in a circuit protected by a fuse or circuit breaker. It is also designed to be installed in accordance with local electrical codes. If you are unsure about your wiring, consult a qualified electrician or local electrical inspector, and check your local electrical code.
4. Avoid looking directly into the lamp.
5. **WARNING: RISK OF CUTS:** To prevent wiring damage, abrasion or cuts, do not expose wiring to edges of sheet metal or other sharp objects and wear gloves.
6. Account for small parts and destroy packaging material, as these may be hazardous to children.
7. Do not make or alter any open holes in an enclosure of wiring or electrical components during kit installation.
8. Installers should not disconnect existing wires from lampholder terminals to make new connections at lampholder terminals. Instead, installers should cut existing lampholder leads away from the lampholder and make new electrical connections to lampholder lead wires by employing applicable connectors.
9. Installers should examine all parts that are not intended to be replaced by the retrofit kit for damage and replace any damaged parts prior to installation of the retrofit kit.



**WARNING:** Check the luminaire (fixture) carefully before installing the lamp. Ensure the electrical lampholders (sockets) are not damaged and will make firm contact with the lamp pins.



**CAUTION: Risk of fire** - If lamp or luminaire exhibit abnormal operation (buzzing, flickering, minimal or no light, etc.), immediately turn off power and contact us for more information.



**CAUTION: Risk of fire** - Suitable for damp locations. Do not use with dimmers. Do not touch lamp pins to the metal housing when installing.



**WARNING:** Do not install this in a pre-heat luminaire (fixture), often with external starters.



**WARNING:** Install this kit only in luminaires that have the construction features and dimensions shown in the photographs and/or drawings and where the input rating of the retrofit kit does not exceed the input rating of the luminaire.



**WARNING:** To avoid potential fire or shock hazard, do not use this retrofit kit in luminaires employing shunted bi-pin lampholders. Note: Shunted lamp holders are found only in fluorescent luminaires with Instant-Start ballasts. Instant-start ballasts can be identified by the words "Instant Start" or "I.S." marked on the ballast. This designation may be in the form of a statement pertaining to the ballast itself, or may be combined with the marking for the lamps with which the ballast is intended to be used, for example F40T12/IS. For more information, contact the LED luminaire retrofit kit manufacturer.

## SAVE THESE INSTRUCTIONS



Thank you for your purchase. Questions, comments or feedback? We'd love to hear from you.

Visit [feit.com/help](http://feit.com/help) for support.

# AVERTISSEMENTS

**Avvertissement :** Risque d'incendie ou de choc électrique. L'installation d'un système DEL nécessite une connaissance des systèmes électriques pour luminaires. N'entreprenez aucune installation si vous n'êtes pas qualifié. Contactez un electricien qualifié.

**Avvertissement :** Risque d'incendie ou de choc électrique. Installer ce kit seulement dans des luminaires qui ayant les caractéristiques de construction et les dimensions mentionnées dans les photographies et/ou les dessins et où la vérification d'entrée du kit retrofit ne déplace pas la valeur d'entrée du luminaire.

**Avvertissement :** Seuls les ouvertures indiquées dans les photos et/ou les dessins peuvent être faits ou modifiés à la suite de l'installation du nécessaire. Il est interdit de laisser d'autres ouvertures dans un boîtier de câblage ou de composants électriques.

**Avvertissement :** Afin d'éviter l'endommagement ou l'abrasion des câbles, éviter tout contact entre ces derniers et le bord d'un objet tranchant tel qu'une tôle.

**Avvertissement de configuration de câblage à une extrémité :** Pour le câblage asymétrique de type B uniquement. Afin d'éviter tout risque d'incendie ou de décharge, ne pas utiliser ce système pour des luminaires utilisant des douilles de lampe bi-contacts court-circuitées. Note : Les douilles de lampe bi-contacts court-circuitées se trouvent généralement dans les luminaires fluorescents avec ballasts à allumage instantané. Ces derniers s'identifient par les termes «instant start» ou «I.S.». Ces termes prennent la forme d'un énoncé relatif au ballast même ou peuvent être ajoutés aux indications concernant les lampes avec lesquelles les ballasts doivent être utilisés (par exemple, F40T12/IS). Pour de plus amples renseignements, veuillez communiquer avec le fabricant du système de luminaire DEL.

**Avvertissement :** Risque d'incendie ou de choc électrique. Ne pas modifier, remplacer ou débrancher les câbles, les douilles d'alimentation, ou toute autre composant électrique.

Les installateurs ne devraient pas débrancher le câblage existant des bornes de douilles de lampes en vue d'établir d'autres connexions à ces bornes. Les installateurs devraient plutôt couper les fils de raccordement des douilles de lampes existants à distance de la douille et établir de nouveaux branchements électriques aux fils de raccordement de la douille en utilisant des accords convenant à cette utilisation.

Le nécessaire de modernisation est accepté à titre de composant d'un luminaire lorsque la pertinence de la combinaison doit être déterminée par les autorités compétentes.

Luminaire lorsque la pertinence de la combinaison doit être déterminée par les autorités compétentes. Ce produit doit être mis en place par un electricien qualifié conformément aux codes électriques appropriés applicables. Le guide d'installation ne supprime pas les réglementations locales ou nationales en matière d'installations électriques.

**ATTENTION :** RISQUE D'INCENDIE. SI LA LAMPE OU UN LUMINAIRE PRÉSENTE UN FONCTIONNEMENT INDÉSIRABLE (BOURDONNEMENT, SCINTILLEMENT, ETC.), COUPER IMMÉDIATEMENT L'ALIMENTATION, RETIRER LA LAMPE DU LUMINAIRE ET CONTACTER LE FABRICANT.

## Limited Warranty

This product is warranted to be free from defects in workmanship and materials for up to 5 years from date of purchase. If the product fails within the warranty period, please contact Feit Electric at [info@feit.com](mailto:info@feit.com), visit [feit.com/contact-us](http://feit.com/contact-us) or call 1-866-326-BULB (2852) for instructions on replacement or refund. REPLACEMENT OR REFUND IS YOUR SOLE REMEDY. EXCEPT TO THE EXTENT PROHIBITED BY APPLICABLE LAW, ANY IMPLIED WARRANTIES ARE LIMITED IN DURATION TO THE DURATION OF THIS WARRANTY. LIABILITY FOR INCIDENTAL OR CONSEQUENTIAL DAMAGES IS HEREBY EXPRESSLY EXCLUDED. Some states and provinces do not allow the exclusion of incidental or consequential damages, so the above limitation or exclusion may not apply to you. This warranty gives you specific legal rights, and you may also have other rights which vary from state to state or province to province.

## FCC STATEMENT

This device complies with part 15 of the FCC Rules. Operation is subject to the following two conditions: (1) This device may not cause harmful interference, and (2) this device must accept any interference received, including interference that may cause undesired operation. Note: This equipment has been tested and found to comply with the limits for a Class B digital device, pursuant to part 15 of the FCC Rules. These limits are designed to provide reasonable protection against harmful interference in a residential installation. This equipment generates, uses and can radiate radio frequency energy and, if not installed and used in accordance with the instructions, may cause harmful interference to radio communications. However, there is no guarantee that interference will not occur in a particular installation. If this equipment does cause harmful interference to radio or television reception, which can be determined by turning the equipment off and on, the user is encouraged to try to correct the interference by one or more of the following measures: Reorient or relocate the receiving antenna. Increase the separation between the equipment and receiver. Connect the equipment into an outlet on a circuit different from that to which the receiver is connected. Consult the dealer or an experienced radio/TV technician for help. Any changes or modifications not expressly approved by the manufacturer could void the user's authority to operate the equipment.

**Supplier's Declaration of Conformity:**  
47 CFR § 2.1077 Compliance Information  
**Responsible Party:** Feit Electric Company  
4901 Gregg Road, Pico Rivera, CA 90660, USA  
562-463-2852

**THIS PRODUCT MAY NOT BE COMPATIBLE WITH ALL BALLASTS.**  
FOR MORE INFORMATION ABOUT BALLAST COMPATIBILITY PLEASE VISIT [WWW.FEIT.COM](http://WWW.FEIT.COM).

# Direct Replacement/Plug & Play Installation Instructions (Type A)

**STEP 1 .** Turn- off power before installation.



**STEP 3 .** Insert the T848/840/AB/U6/LED tube into the lamp holder.

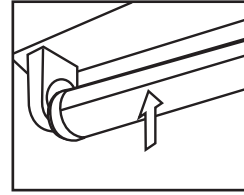

**STEP 2 .** Remove cover plate and existing bulbs in the fixture.

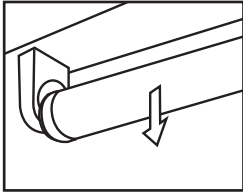

**STEP 4 .** Turn-on power and enjoy new Feit LED Tube.

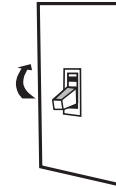

# T8 OR T12 BALLAST BYPASS INSTALLATION INSTRUCTIONS (TYPE B)

**STEP 1 .** Turn- off power before installation.



**NOTE:** THE RETROFIT KIT IS ACCEPTED AS A COMPONENT OF A LUMINAIRE WHERE THE SUITABILITY OF THE COMBINATION SHALL BE DETERMINED BY AUTHORITIES HAVING JURISDICTION. PRODUCT MUST BE INSTALLED BY A QUALIFIED ELECTRICIAN IN ACCORDANCE WITH THE APPLICABLE AND APPROPRIATE ELECTRICAL CODES. THE INSTALLATION GUIDE DOES NOT SUPERSEDE LOCAL OR NATIONAL REGULATIONS FOR ELECTRICAL INSTALLATIONS.

**STEP 2 .** Remove the existing ballast and existing starter (if present) from the fixture.

## MAGNETIC BALLAST

**STEP 1**

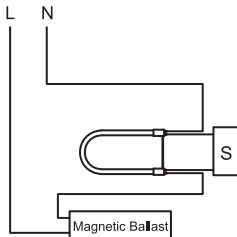

**STEP 2** The wiring can be single end or double end. The connection method refers to step3.

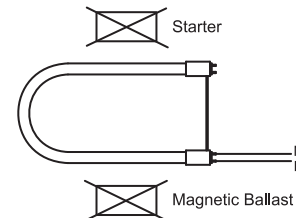

## ELECTRONIC BALLAST

**STEP 1**

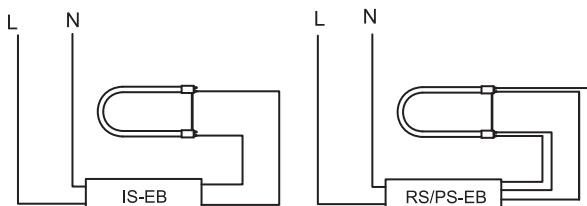

**STEP 2** The wiring can be single end or double end. The connection method refers to step3.

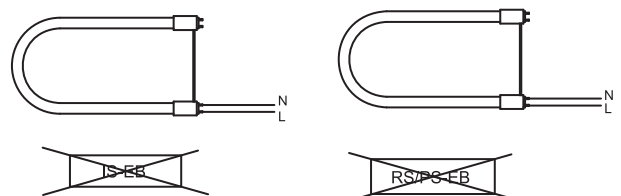

**STEP 3 .** Rewire the fixture to be one certain single end/double end power.

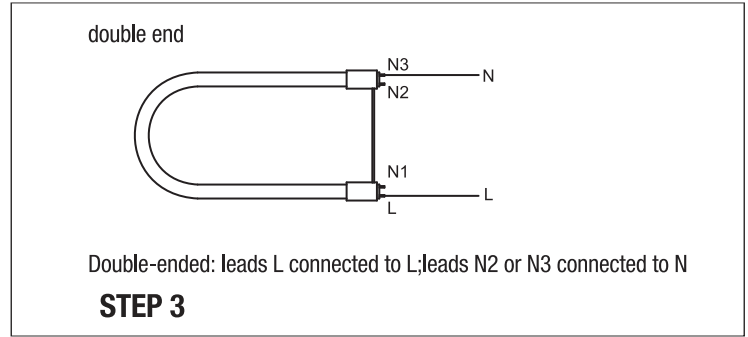
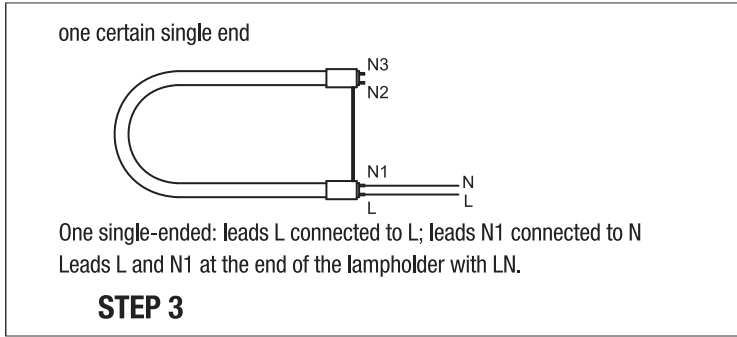

**CAUTION: Use only non-shunted lampholders for Single-Ended wiring installations.** Do not perform Single-Ended wiring installation of product in a fixture with shunted lampholders (found in all fixtures using instant start ballasts). If the existing lampholders are shunted, and Single-Ended wiring is desired, remove and replace them with non-shunted lampholders (or remove the external shunt if applicable). Make new connections directly to lampholder terminals as shown in Figure1 below.

**Typical Non-Shunted Lampholder**

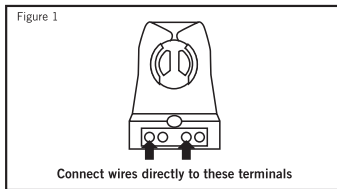

If it is non shunted socket, it can work in both single end and double end.

**Typical Shunted Lampholders**

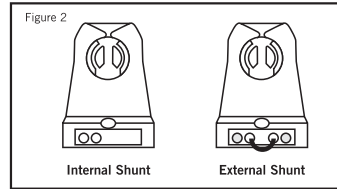

If it is shunted socket, it is double end only.

**T8 OR T12 BALLAST BYPASS INSTALLATION INSTRUCTIONS (TYPE B)**

After wiring modification is completed, attach the replacement cautionary label onto a visible place on the fixture that is kept visible after installation of LED U-bend.

Remove any pre-existing labels and replace them with the labels provided with this product.

**⚠ WARNING!**  
 USE LED LAMPS ONLY. THIS LUMINAIRE HAS BEEN MODIFIED TO USE LED LAMPS AND CAN NO LONGER OPERATE THE ORIGINALLY INTENDED LED U-bend SAFELY.  
 LED U-bend COULD BREAK AND CAUSE PERSONAL INJURY IF USED IN THIS FIXTURE.

**STEP 4 .** Install the Feit LED U-bend.

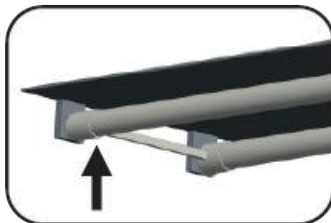

**LED U-bend**

**STEP 5 .** Turn-on the power and enjoy your Feit LED U-bend.

