

7" ANGLE POLISHER

Stock Number M647

OWNER'S MANUAL

SPECIFICATIONS:

Air pressure (P.S.I.):	90
Average air consumption (C.F.M.):	5
Free speed (R.P.M.):	2,500
Spindle Thread:	5/8 - 11
Air inlet (N.P.T.):	3/8
Hose size (I.D.):	1/2 in.
Weight (LBS.):	4.19

Specifications are subject to change without notice.



Performance Tool®

LIMITED WARRANTY

PERFORMANCE TOOL® extends only the following warranties, and only to original retail purchasers. These warranties give specific legal rights. Except where prohibited by local law, the law of the State of Washington governs all warranties and all exclusions and limitations of warranties and remedies. There may be other rights which vary from state to state.

PERFORMANCE TOOL® warrants the product to be free from defects in materials and workmanship under normal use and service. A defective product may be returned for a free replacement within 90 days from the date of purchase, provided that product is returned to place of purchase immediately after discovery of defect. After 90 days and up to one year from date of purchase, PERFORMANCE TOOL® will replace at no charge any parts which our examination shall disclose to be defective and under warranty. These warranties shall be valid only when a sales receipt showing the date of purchase accompanies the defective product or defective part (s) being returned. For part (s) after 90 days, please remit your request, postage prepaid to:

PERFORMANCE TOOL, P.O. Box 88259 Tukwila, WA 98138

These warranties exclude blades, bits, punches, dies, bulbs, fuses, hoses, and other consumables which must be replaced under normal use and service. These warranties shall not apply to any product or part which is used for a purpose for which it is not designed, or which has been repaired or altered in any way so as to affect adversely its performance or reliability, nor shall these warranties apply to any product or part which has been subject to misuse, neglect, accident or wear and tear incident to normal use and service.

PERFORMANCE TOOL® does not authorize any other person to make any warranty or to assume any liability in connection with its products.

Except for warranties of title and the limited express warranties set forth above, PERFORMANCE TOOL® makes no express or implied warranties of any kind with respect to its products. In particular, PERFORMANCE TOOL® makes no implied warranty of merchantability and no implied warranty of fitness for any particular purpose, except that for goods purchased primarily for personal, family or household use and not for commercial or business use, PERFORMANCE TOOL® makes an implied warranty of merchantability (and, if otherwise applicable, an implied warranty of fitness for a particular purpose), but only for the particular qualities or characteristics, and for the duration, expressly warranted above.

The laws on limitation of implied warranties may differ from state to state, so the above limitations may not apply in all cases.

PERFORMANCE TOOL® shall not be liable for consequential, incidental or special damages resulting from or in any manner related to any product, or to the design, use, or any inability to use the product. The sole and exclusive remedy for a defective product or part shall be the repair, or replacement thereof as provided above. The laws on limitation of remedies or on consequential, incidental or special damages may vary from state to state, so the above limitations may not apply in all cases.

© Copyright 2017 WILMAR CORPORATION, P.O. Box 88259 Tukwila, WA 98138

WARNING!

READ, UNDERSTAND AND FOLLOW ALL INSTRUCTIONS AND WARNINGS BEFORE OPERATING THIS TOOL. FAILURE TO DO SO MAY RESULT IN PERSONAL INJURY AND/OR PROPERTY DAMAGE AND WILL VOID WARRANTY.

Some dust created by power sanding contains chemicals known to the State of California to cause cancer, birth defects or other reproductive harm. An example of this type of chemical is lead from lead based paints, Crystalline Silica from bricks and cement or other masonry, Arsenic and Chromium from chemically treated lumber. Your risk from these exposures varies, depending on how often you do this type of work. To reduce your exposure: work in a well ventilated area and work with approved safety equipment, such as dusk masks that are specially designed to filter out microscopic particles.

PT
Performance Tool

IMPORTANT SAFETY INFORMATION

WARNING!

READ, UNDERSTAND AND FOLLOW ALL INSTRUCTIONS AND WARNINGS BEFORE OPERATING THIS TOOL. FAILURE TO DO SO MAY RESULT IN PERSONAL INJURY AND/OR PROPERTY DAMAGE AND WILL VOID WARRANTY.

1. Use only paper sanding disks with the proper adhesive. Read, understand and follow all adhesive manufacturers' directions. **DO NOT USE CLOTH BACKED SANDING DISKS WITH THIS TOOL.**
2. Make sure sanding pad RPM rating matches Free Speed rating of this tool.
3. Wear a dust mask while operating this tool. Read, follow and understand manufacturers instructions on paint, primer, paint preps, glazing, body filler, etc. for additional respirator and ventilating requirements.
4. Always use approved eye and ear protection when using air powered tools. If raising dust/debris, wear a suitable mask. Do not wear loose clothing or jewelry.
5. Always operate tool a safe distance from yourself and others in the work area. Keep footing and balance at all times.
6. Make sure work piece is secure to allow safe operation of the tool with both hands. Do not hold the work piece in your hand, lap or against any part of your body.
7. Make sure trigger is in the "off" position before connecting or disconnecting the tool from air source. Disconnect tool from air source before changing accessories, performing service and when not in use.
8. Follow air source manufacturer's directions for connection of regulators, filters and other accessories to air source. Do not install quick couplers directly at tool air inlet. This causes inlet failure due to excess weight and vibration. Use a whip hose between tool and quick couplers.
9. **DO NOT OVERLOAD!** Do not force tool. Match tool capacity to work load requirement. Use tool within its rated capacity and only for its designated purpose. Overloading air tools will cause premature wear and/or permanent damage of internal and external drive parts and will void warranty.
10. Inspect hoses and fittings for wear and damage prior to using tool. Do not carry or drag tool by the air hose. Keep air hose free from obstruction, twisting and binding.

TROUBLESHOOTING

INSUFFICIENT POWER:

Probable Cause	Solution
Dirty or clogged air passages.....	Flush and lubricate tool, drain air tank and supply line
Insufficient air supply.....	Increase line pressure, Make sure compressor matches tool's air pressure and consumption needs
Air leakage.....	Use PTFE tape at all fittings and joints. Check tool for worn or damaged O-rings & seals.
Worn/damaged wear & tear parts...	Replace as necessary.
Tool matching	Be sure you are using a tool suited for the torque requirements of the job at hand.

PARTS LIST

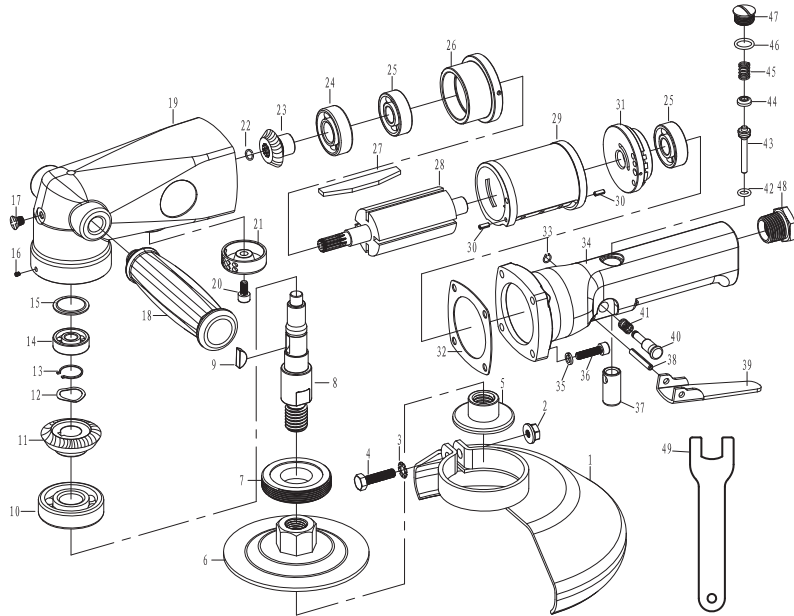

No.	DESCRIPTION	QTY	No.	DESCRIPTION	QTY
1.	Air Inlet Cover	1	24.	Bearing	1
2.	Air Inlet Screw	1	25.	Bearing	1
3.	Screw	8	26.	Gear	1
4.	Washer	8	27.	Gear Housing	1
5.	Body	1	28.	Exhaust Deflector	1
6.	Screw	1	29.	Screw	2
7.	O-Ring (15 x 2.4)	1	30.	Side Handle	1
8.	Valve Spring	1	31.	Dust Cover	1
9.	O-Ring (9.6 x 2)	1	32.	Bearing	1
10.	O-Ring (8 x 1.6)	1	33.	Woodruff Key	1
11.	Valve Stem	1	34.	Arbor	1
12.	Valve Cover	1	35.	Retaining Ring	1
13.	Trigger Pin	1	36.	Wave Washer	1
14.	Trigger	1	37.	Gear	1
15.	Gasket	1	38.	Housing Cap	1
16.	Ring	1	39.	Bearing	1
17.	Cylinder Pin	1	40.	Bearing Washer	1
18.	Bearing	1	41.	Circlip	1
19.	Back Cover	1	42.	Sanding Pad	1
20.	Rotor	1	43.	Lock Nut Wrench	1
21.	Rotor Blade	4	44.	Wrench	1
22.	Cylinder	1	45.	Lock Nut	1
23.	Front Cover	1			

ASSEMBLY

1. Thread the Side Handle (30) into the side of the Gear Housing (27) until tight.
2. Thread raised side of Pad onto Lock Nut (45).
3. Place the grinding wheel or backing pad onto Lock Nut (45).
4. Thread Sealing Ring (5) onto Lock Nut (45) making sure flange faces out.
5. Place Wrench (44) on Arbor (34) and the Lock Nut Wrench (43) on the Lock Nut (45) and tighten.

SETUP

1. Designate a clean and well-lit work area. Work area must not allow access by children or pets to prevent distraction and injury.
2. Route the air hose along a safe path to reach the work area without creating a tripping hazard or exposing the air hose to possible damage. Make sure air hose is long enough to reach work area with enough slack to allow free movement while working.
3. Secure loose work pieces using a vise or clamps to prevent movement while working.
4. Make sure there are no hazardous objects (such as utility lines or foreign objects) nearby that will present a hazard while working.
5. If an automatic oiler is not used, put a few drops of Pneumatic Tool Oil into tool at air inlet connection before use. Add a few more drops after each hour of continual use.
6. Set the compressor to 90 PSI.

OPERATION

Sanding Instructions:

1. Position the sanding disc (sold separately) in the center of the Pad, making sure there is equal overhang on the disc.
2. Grip tool with both hands and place onto the area to sand.
3. Squeeze the Trigger (14). You can vary the speed of the tool to suit your needs by varying the amount of pressure applied.
4. Move tool in a uniform pattern, either up or down or side to side to ensure even sanding.
5. Periodically check tool for any potential disc wear. Replace used disc when necessary.

Grinding Instructions:

1. Attach grinding wheel as indicated in Assembly.
2. Grip tool with both hands and place onto the area to sand.
3. Squeeze the Trigger (14). You can vary the speed of the tool to suit your needs by varying the amount of pressure applied.
4. Move tool in a uniform pattern, either up or down or side to side to ensure even grinding.
5. Periodically check the tool for any potential wear. Replace used grinding wheel when necessary.

OPERATION

Polishing/Buffering Instructions:

1. Attach a polishing bonnet (sold separately) and apply a small amount of the appropriate polishing compound onto the bonnet in a circular (or swirl) fashion.
3. Grip tool with both hands and place tool onto the area you wish to polish.
4. Squeeze trigger (14) halfway down. Move the tool in a random pattern.

CAUTION! Do not polish in one position for more than a few seconds.

5. Once you've covered the desired area, stop and replace bonnet with a new bonnet for buffering operation.
6. Avoid polishing body part edges. Use hand force to prevent possible damage to auto body finish.
7. Buff polished area the same way, applying light pressure and moving in a random pattern until the compound has been removed.
8. Use a clean, lint-free cloth to remove any compound from crevices that could not be reached with Tool.
9. If the tool requires more force to accomplish the task, verify that the tool receives sufficient, unobstructed airflow (CFM) and increase the pressure (PSI) output of the regulator up to the maximum air pressure rating of this tool.

CAUTION! To prevent tool and accessory failure, resulting in injury: Do not exceed tools maximum air pressure rating.

10. If tool still does not have sufficient force at maximum pressure and sufficient airflow, a larger tool may be required.
11. To prevent accidents, turn off the tool, detach the air supply, safely discharge air pressure, and release the trigger. Clean external surfaces of the tool with clean, dry cloth, and apply a thin coat of tool oil. Then store the tool indoors out of children's reach.

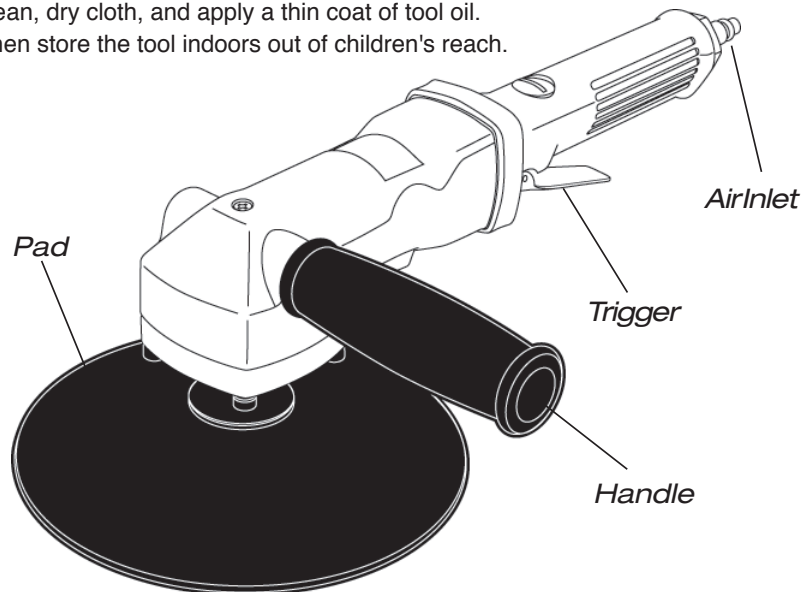

AIR SOURCE

Clean air of correct air pressure is recommended for the power supply for this tool. A maximum of 90 PSI at the tool is recommended for most air tools of this class. Check specifications section for recommended pressure. (Depending on length of air hose and other circumstances, air pressure at compressor may need to be increased to 100 PSI to ensure 90 PSI at the tool.)

Water in the air hose and compressor tank contributes to reduced performance and damage of the air tool. Drain the air tank and filters before each use and as necessary to keep the air supply dry. Hose length over 25' causes loss in line pressure. Increase hose I.D. or increase compressor pressure to compensate for the pressure loss. Use an in-line pressure regulator with gauge if air inlet pressure is critical.

LUBRICATION & MAINTENANCE

Oil tool before each use. 4 to 5 drops of a good grade Air Tool Oil placed in the air inlet is sufficient. Use proper air pressure and CFM rating listed for this tool.

Drain water from hoses and compressor tank. Water in the air supply line will cause gumming and loss of power. Clean the air filter on the supply line and flush the tool with gum solvent or a 50/50 mix of air tool oil and kerosene. It may be necessary to disassemble the tool to properly clean and re-lubricate.



Yes

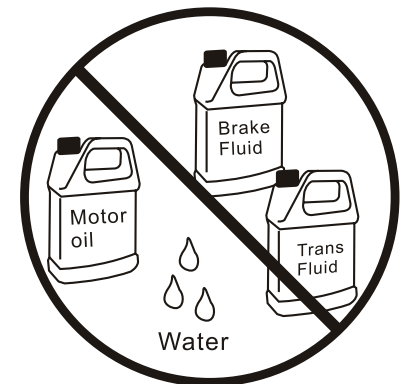

No