

JACK & JUNE

CEDAR TOY CHEST

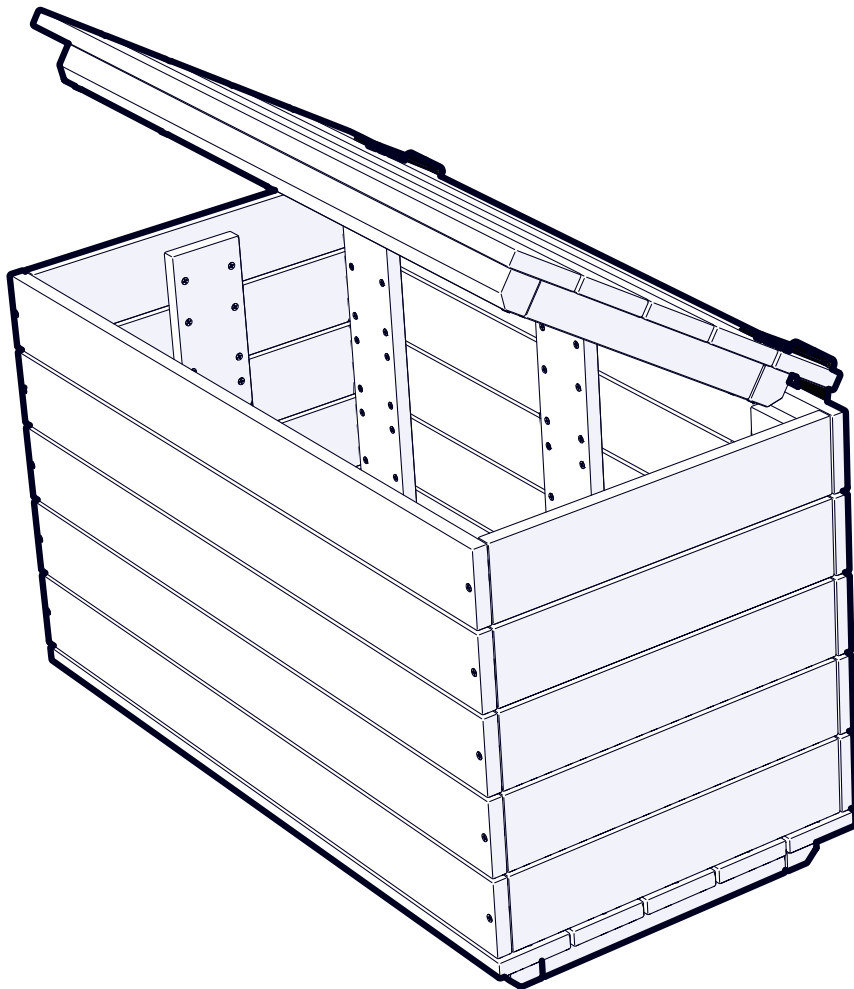

JJ-TOYCHEST

PRE-ASSEMBLY TIPS

1. **Read this manual carefully before starting assembly.** Read each step completely before beginning each step.
2. **Some smaller parts may be shipped inside larger parts. Check inside all parts and cartons before assembling or ordering parts.**
3. **To make assembly easier, use the Identifier on page 3-4 to identify and sort all parts. Check all cartons for kits.**
4. **Do not tighten until instructed to do so. If parts are tightened too soon, parts may not easily fit together.**
6. **Save these instructions and your proof of purchase (receipt) in the event that the manufacturer has to be contacted for replacement parts.**



Please Do Not Return This Product To The Store!

Contact Escalade® Sports customer service department at:

Phone: 1-800-USA-GOAL Toll – Free !

Fax: 1-866-873-3536 Toll – Free !

E-mail: basketball@escaladesports.com

Escalade Sports

Physical Location: Mailing Address: (Correspondence Only)

817 Maxwell Ave. PO Box 889

Evansville, IN 47711 Evansville, IN 47706

PARTS LIST (NOT ACTUAL SIZE)

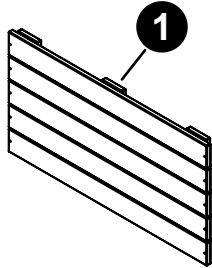

FRONT PANEL
JJ-TOYCHEST-FRT
QTY. 1

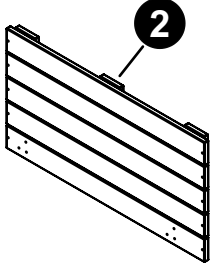

BACK PANEL (with pilot holes)
JJ-TOYCHEST-BACK
QTY. 1

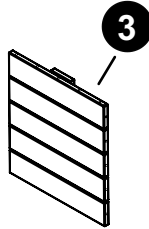

SIDE PANEL
JJ-TOYCHEST-SIDE
QTY. 2

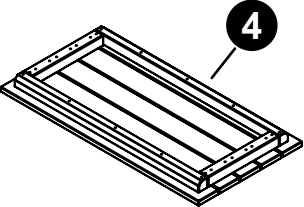

BOTTOM PANEL
JJ-TOYCHEST-BTM
QTY. 1

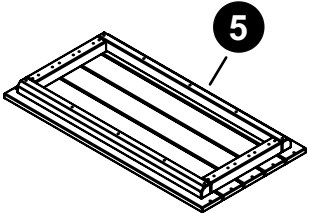

LID (with pilot holes)
JJ-TOYCHEST-LID
QTY. 1

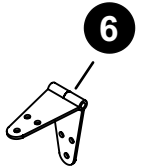

HINGE
PG-AC-0051
QTY. 2

HARDWARE IDENTIFIER (ACTUAL SIZE)

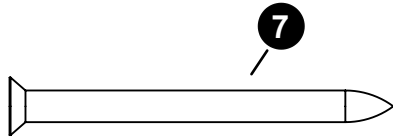

#8X2.25" FLAT HEAD WOOD SCREW
PG-HW-S004
QTY. 30

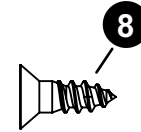

#8 X .5" FLAT HEAD SCREW
PG-HW-S023
QTY. 12

TOOLS NEEDED



PHILLIPS SCREW DRIVER

NOTE:

An electric screwdriver is helpful in assembly. However, please set at **low torque and use extreme caution** with an electric screwdriver because you could over-tighten the hardware & strip out the screws.

STEP 1:

On a flat surface attach (#1) Front Panel to (#3) Side Panels with (#7) Screws, then attach the (#2) Back Panel that has the pre-drilled hinge holes.

NOTE: All panels have a top side and bottom side. The top side has the support offset 3/4" from the edge.

FIGURE 1

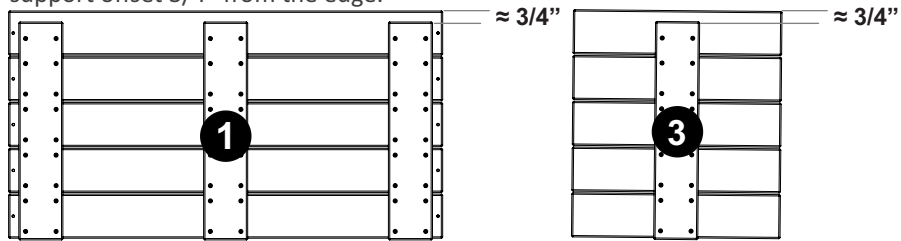

NOTE: End of (#1) & (#4) panels with 3/4" offset face up.

NOTE: Back panel (#2) with pre-drilled holes. See Back View.

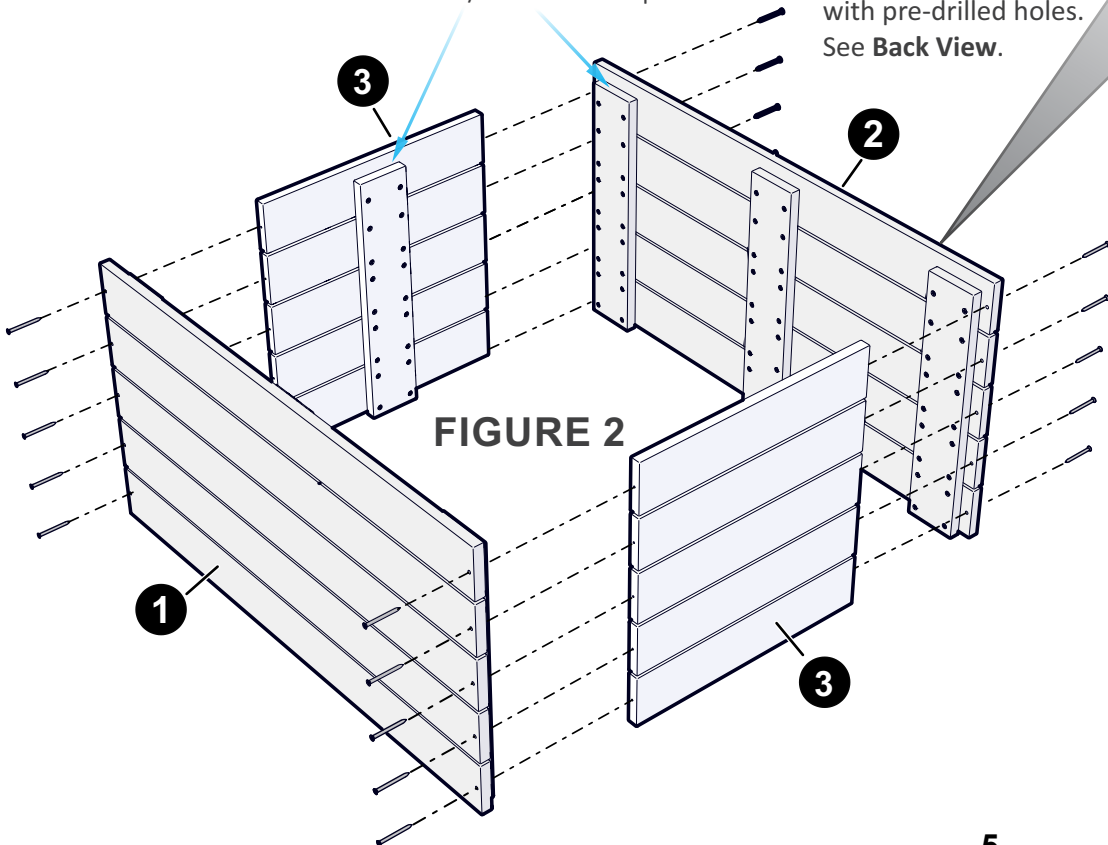
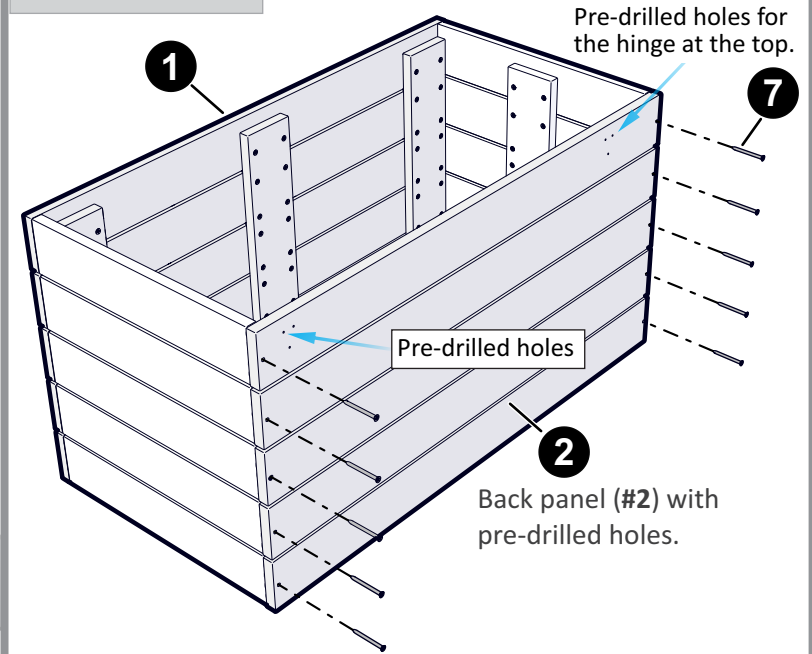

FIGURE 2

BACK VIEW



NOTE: The back panel will have pre-drilled holes for the hinges. Make sure the holes are at the top as shown.

STEP 2:

Position the assembly as shown on a clean flat surface and attach **(#4)** Bottom Panel with ten **(#7)** screws.

NOTE: **(#4)** Bottom Panel does not have any hinge pilot holes.

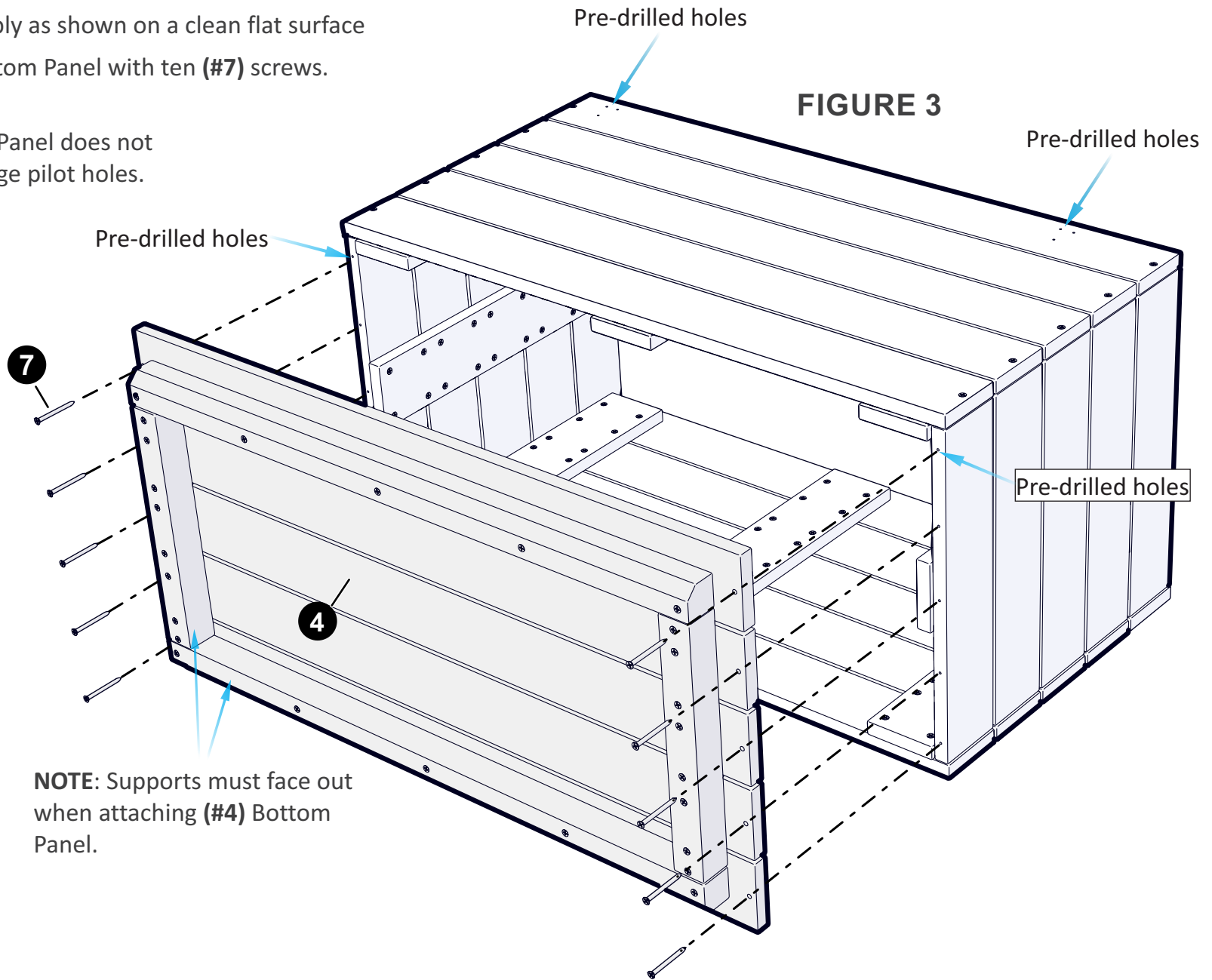

STEP 3:

Place the (#5) Lid on the Box as shown with the pre-drilled holes on the same side. See **Figure 4**.

STEP 4:

Line up the holes on the hinges to the pre-drilled holes on Lid and Back panel and attach as shown in **Detail A**.

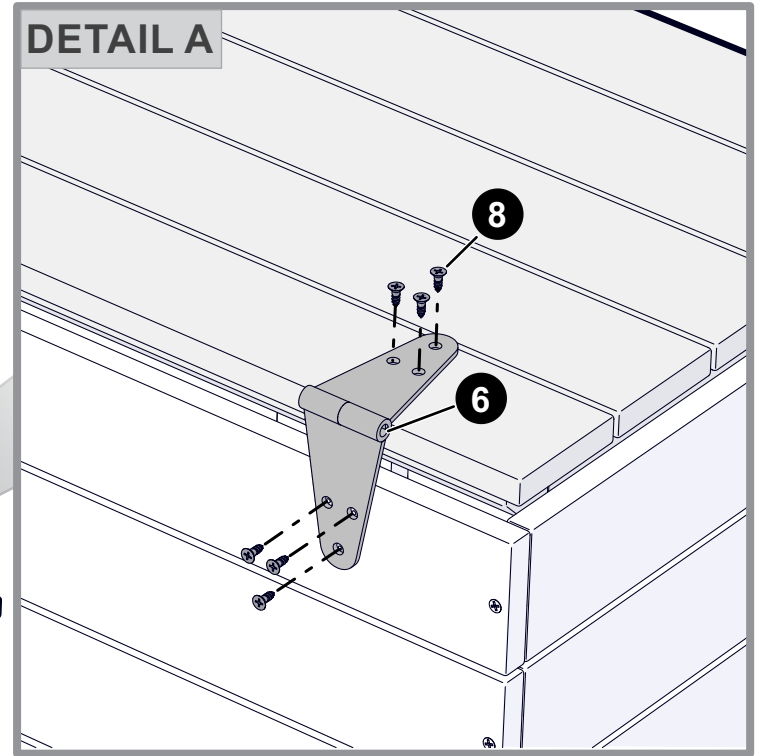
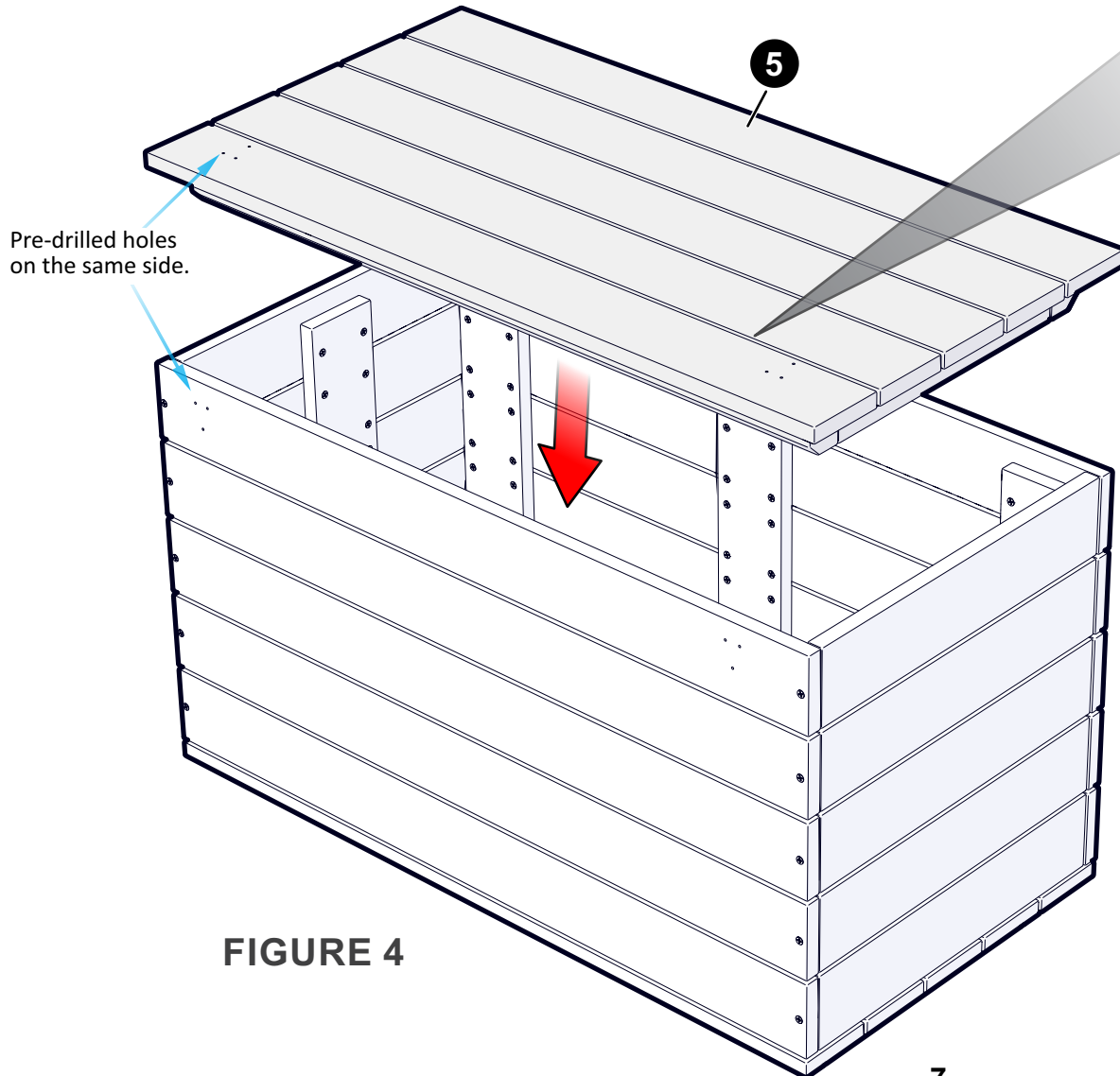

JACK & JUNE WARRANTY

1 Year Warranty

Subject to proper installation and normal residential use, Jack & June warrants, subject to the limitations stated below, to the original retail purchaser, parts to be free from defects in material and workmanship for a period of **one year** from date of purchase. Merchandise covered under this limited **one-year** warranty will, at our option, be repaired or replaced, excluding any freight or labor fees.

For **one Year** after the original purchase date of our **products**, Jack & June warrants, to the original retail purchaser, all wooden components against structural failure due to corrosion, wood rot, or insect infestation. Seasonal checks, surface cracks, knotholes and knots, not resulting in structural failure, are natural characteristics of all wooden play equipment, are not covered under this warranty and will not affect the integrity of your playset.

Jack & June warrants to the original retail customer that we will replace any hardware that fail due to rust or breakage (excludes surface rust).

Timber is a natural material which can absorb and release moisture. Although this product is designed to minimize this effect, in certain circumstances some movement or distortion is unavoidable. During dry hot weather timber may shrink and check - this is a normal process of weathering. After the first year of service it is advisable to clean and apply a non-toxic stain or sealant to the wood, safe for children's use.

Components covered under this **1 year** warranty will be replaced free of charge excluding freight and labor fees.

Non-residential use of the playset is prohibited and voids the warranty as the playsets are designed for residential use only.

Escalade Sports reserves the right to examine photographs and/or physical evidence of merchandise claimed to be defective, and to recover said merchandise, prior to disposition of warranty claims. Merchandise returned to our factory for examination or recovery must be shipped freight prepaid, unless a Return Authorization Number is issued.

This warranty program does not cover normal wear and tear, color fading, or damages resulting from misuse, abuse, vandalism, alteration, acts of God, or assembly and maintenance contrary to our instructions. Escalade Sports assumes no responsibility for incidental or consequential damages which may arise from the purchase or use of our equipment. Please supervise your children's play activity and maintain your play equipment periodically.

This warranty is expressly in lieu of all other warranties, expressed or implied, including warranties of merchantability or fitness for use. Jack & June does not assume or authorize any person to assume for us, any other liability in connection with the sale of our products.

Special Note: Jack & June reserves the right to make changes in materials, design, and pricing without notice. See your instruction manual for maintenance requirements. Your child's safety is your responsibility; therefore, you should inspect this equipment regularly for wear and safety.

For warranty service, contact:

Escalade Sports

P.O. Box 889

Evansville, IN 47706

1-800-GO-SWING

Or E-Mail us at: playgroundcs@escaladesports.com