

INSTRUCTION MANUAL

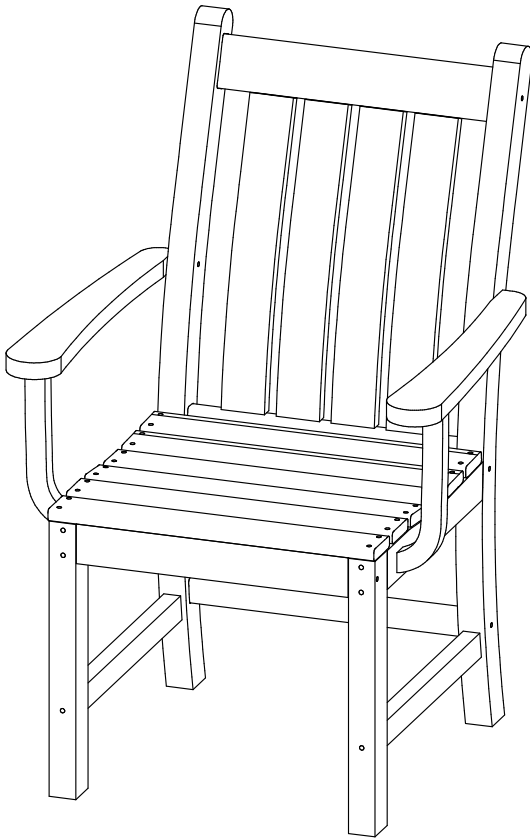

Laguna Patio Dining Armchair
SKU:OP2006

V1.0

! NOTICE

Do not overtighten screws. (Insert all screws before tighten screws.)

- Please do not exceed the weight limitations of this item.
- Do not stand on or use any part of this item as a step ladder.
- Firmly secure all bolts, screws and nuts before use.
- Reconfirm that all bolts, screws, and nuts are secure every 90 days.
- Do not use or store this item in the proximity of open flame or flammable/combustible chemicals.
- Be aware that some parts are heavy and have sharp edges.
- Please adjust the speed slowly when you use electric drill for assembling to avoid screw slippage.

TOOLS REQUIRED

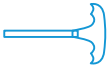

ALLEN WRENCH
(PROVIDED)



SCREWDRIVER BLADES
(PROVIDED)



CHAIR
330 LBS
CAPACITY



1 PERSON
ASSEMBLY



UP TO 30 MIN.
ASSEMBLY

HARDWARE

1

M6.3 x 80mm
BOLT



12 PCS

2

M6.3 x 60mm
BOLT



2 PCS

3

M6.3 x 50mm
BOLT



2 PCS

4

ALLEN
WRENCH

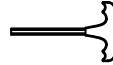

1 PC

5

SCREWDRIVER
BLADES



1 PC

6

ALLEN
WRENCH



1 PC

PARTS

A

CHAIR FRONT LEG

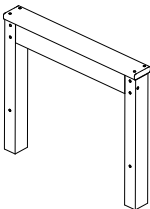

1 PC

B

CHAIR BACKREST

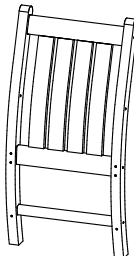

1 PC

C

CHAIR SEAT

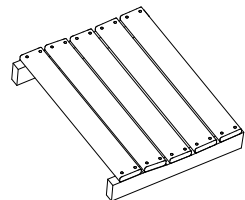

1 PC

PARTS

D

SIDE RAIL

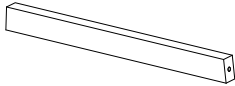

2 PCS

E

CHAIR RIGHT ARM

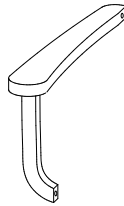

1 PC

F

CHAIR LEFT ARM

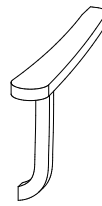

1 PC

PRODUCT ASSEMBLY - OVERALL VIEW

1

Look at following overall view of this chair and learn the exact position of each parts to be assembled.

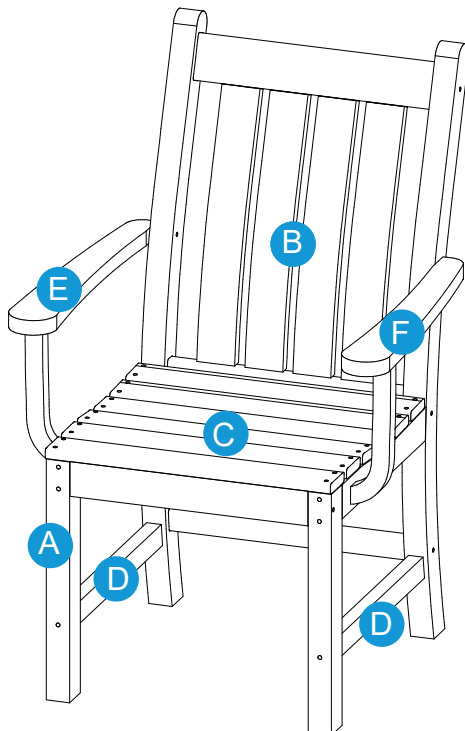

PRODUCT ASSEMBLY

1

Attach part A Chair Front Leg to part C Chair Seat with 4 pcs of Hardware 1 Bolt ,

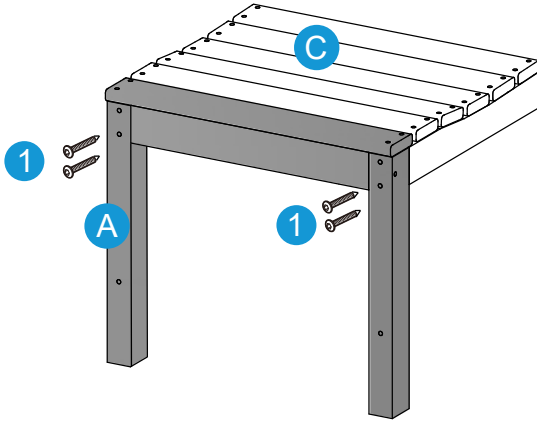

2

Attach part B Chair Backrest to part C Chair Seat with 4pcs of Hardware 1 Bolt

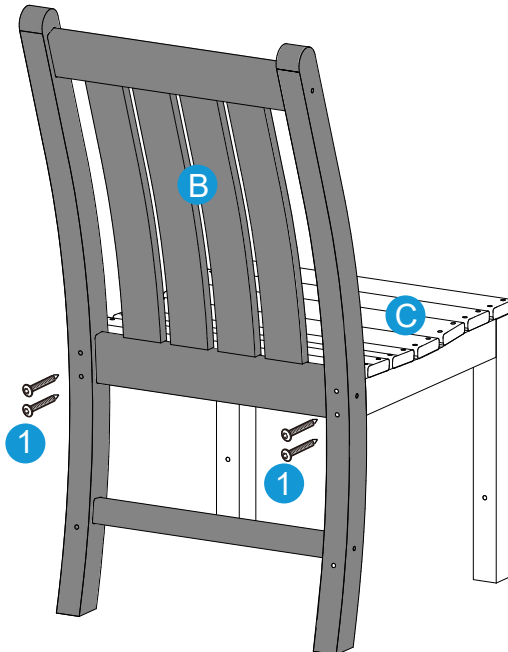

PRODUCT ASSEMBLY

3

Attach part D Side Rail between part B Chair Backrest and part A Chair Front Leg with 4 pcs of Hardware 1 Bolt

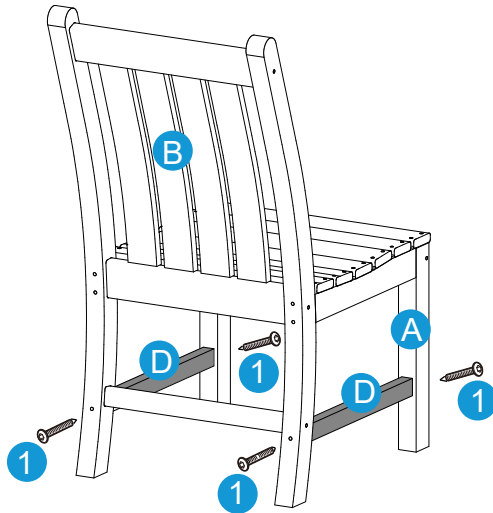

4

Attach part E Chair Right Arm to Part B Chair Backrest with 1 pc of Hardware 2 Bolt, and part C Chair Seat with 1 pc of Hardware 3 Bolt. Do the same to attach part F Chair Left arm to part B Chair Backrest and part C Chair Seat.

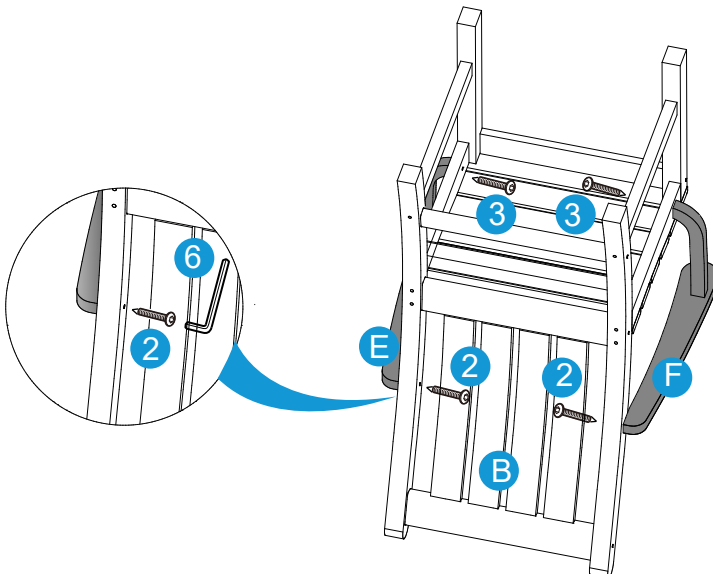

Check and tighten all the bolts and screws again and finish the assembly.

