

Thank you for choosing Sunnydaze Decor. We stand behind our brand and the quality of the items we sell. Replacement parts or products will be sent at our discretion within the 1-year warranty period. Proof of purchase, with the date of purchase as well as photos of the merchandise defect, must be provided. Photos are used to determine the cause of defects and for future quality control. Register your warranty at <https://tiny.cc/SunnydazeWarranty>. If you have any questions, comments or concerns, feel free to contact us by phone at 833-982-1977, by email: customerservice@sunnydazedecor.com, or via our contact us page at <https://tiny.cc/SunnydazeContact>

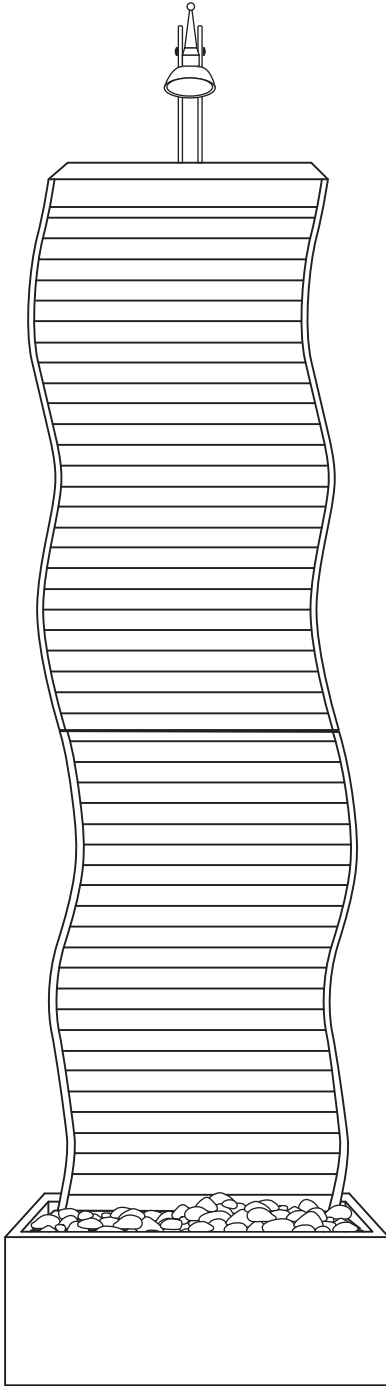

CURVED RIDGE SLATE WATER FOUNTAIN GSI-6051

Review all assembly and care information before using this product.

Save this manual for future reference.

Select a smooth, level surface to place the fountain.

Assemble components on a soft, clean surface to avoid scratching or damaging the finish.



Inspect packaging to ensure all parts are accounted for before disposing of packing materials.
 Save the packing slip.

No.	PARTS	QTY.
A	Basin	1
B	Electric Submersible Pump	1
C	Lower Fountain Body	1
D	Upper Fountain Body	1
E	M6x25mm Bolt Set	6
F	LED Light	1
G	AC Adapter	1
H	Pump Access Panel	1
I	Decorative Stones	1 PK



2-PERSON ASSEMBLY RECOMMENDED

TOOLS REQUIRED (not included)



Phillips Screwdriver



NOTE: The LED light switch is NOT rated for contact with water. The switch may become permanently damaged if it is exposed to water.

IMPORTANT INFORMATION ABOUT SLATE FOUNTAINS:

- Slate is a natural product; the colors and texture of each piece are unique, no two fountains will look the same. Variations in the cuts and colors of the slate are normal.
- Each piece is cut from a large slab of slate. Spalling (flaking) may occur during product production, naturally over time, and/or if slate is dropped.

Variations in the natural characteristics of slate are not a cause for return.

ASSEMBLY

! HELPFUL HINTS

The water tubing is built into the fountain body. Take care when handling the water tube; detaching the water tube will damage the fountain and void the product warranty.

Before assembly, check the basin for leaks. The sealant used to join the slate pieces can crack if the fountain is not handled with care. Simply add water and wait to see if water begins to leak. If a leak is discovered, contact an expert at your local hardware store for an appropriate sealant and carefully follow the sealant manufacturer's instructions to seal the leak.

WARNING: THE ONE-YEAR WARRANTY DOES NOT COVER DAMAGES OR DEFECTS CAUSED BY THE APPLICATION OF CHEMICAL TREATMENTS, PROTECTIVE COATINGS, SEALANTS, OR CLEANING PRODUCTS.

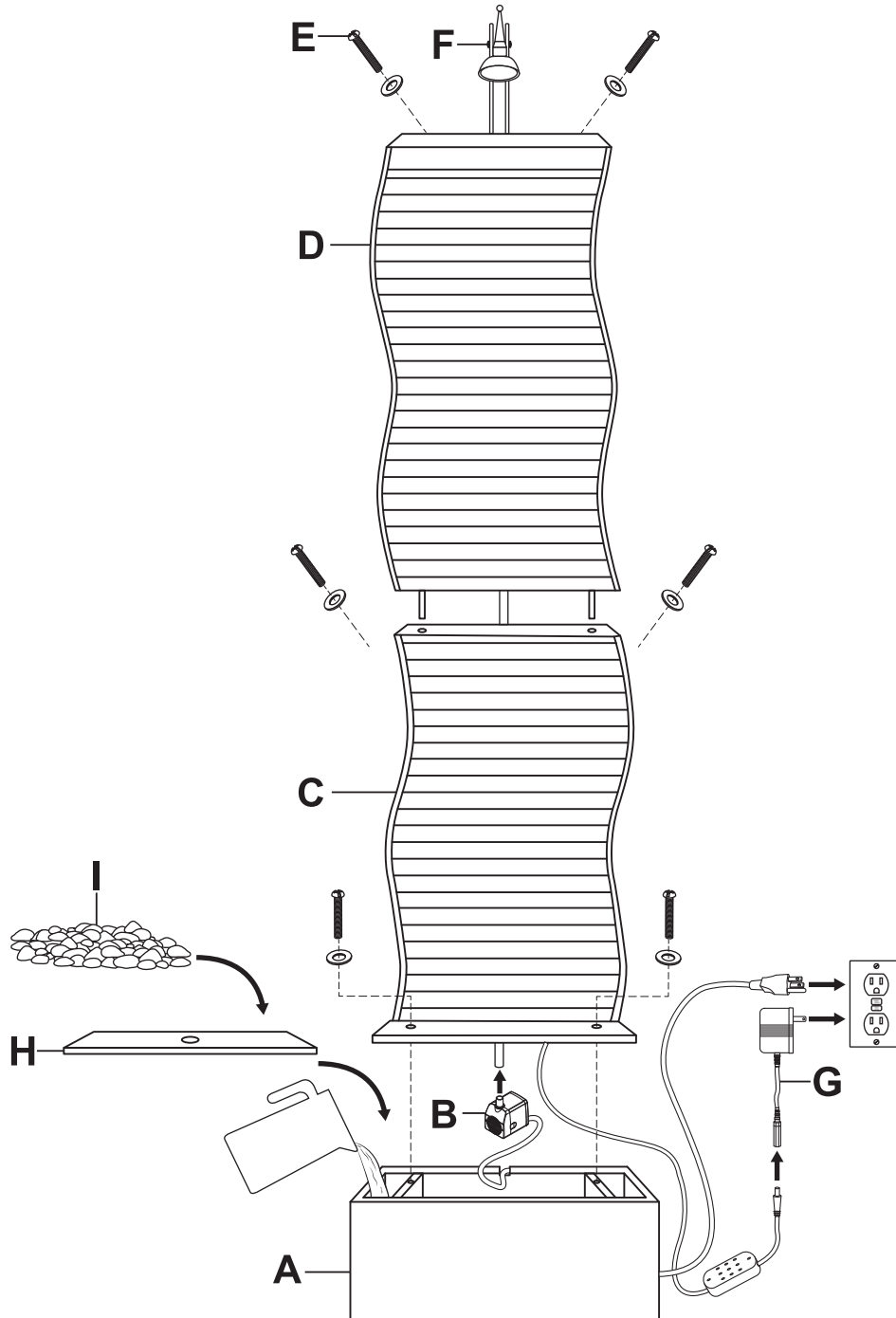

1. Set Pump (B) in Basin (A) and run the power cord over the back of it.
2. Remove Bolt Sets (E) from the basin. Then, use the bolts to install Lower Fountain Body (C) to the basin.
3. Place Upper Fountain Body (D) onto the lower fountain body and secure using two Bolt Sets (E).
4. Connect the pump to the water tube.
5. Gently place Pump Access Cover (H) on the front of the basin.
6. Fasten LED Spotlight (F) to the backside of the upper fountain body using two Bolts (E). Then, connect AC Adapter (G) to the light cable.
7. Fill the fountain with enough water to keep the pump fully submerged during operation.
8. Plug both power cords directly into a properly grounded GFCI outlets.
9. If necessary, adjust water flow rate using the flow control on the front of the pump. Once water flow is satisfactory, rinse Decorative Stones (I) with clean water and gently arrange them on the bottom of the fountain body.

Note: When first plugged in, there may be air in the pump. It may take several moments for trapped air to escape, allowing water to flow.

Care & Maintenance

- For indoor use only if the LED spotlight is installed. To use outdoors, remove the LED spotlight (the light switch is not waterproof).
- Always protect surfaces that can be damaged by water. Splashing is possible; adjust the flow rate on the pump if the water rate is too high.
- Check the water level frequently to ensure the pump remains fully submerged; never allow the pump to run dry as it will burn out the motor.
- Some climates and weather conditions increase water evaporation, requiring water to be added more frequently. Frequently check water levels, especially during high temperatures, long-term exposure to direct sunlight, and windy conditions to ensure the pump does not run dry.
- Only use water in this fountain. Distilled water will help prevent mineral buildup but is not required. Tap water is okay to use, but avoid heavily chlorinated water as it may damage the fountain and pump.
- Periodically change the water to reduce scale and buildup — clean components regularly for optimal performance and appearance. DO NOT use abrasive materials and harmful additives such as bleach or chlorine to clean the fountain or pump. Additionally, never use a pressure washer to clean this unit.
- Always unplug the power supply before cleaning and maintaining the fountain and the recirculating pump.
- Take care when handling the pump; only pick it up by the body of the pump, never the power cord.
- During freezing temperatures, drain the fountain, disconnect the pump and store indoors; allowing ice to form may damage the fountain in such ways as, but not limited to, fountain cracking and/or permanent pump damage.

Troubleshooting

- If water is not flowing within several moments of the fountain being plugged in, ensure the pump is fully submerged underwater. Add water to the reservoir if necessary. The pump may have air bubbles in the filter that can prevent water from circulating properly and can also cause excess pump noise. Unplug the power supply for a few moments and plug it back in.
- Check the flow control on the body of the pump, it may need to be adjusted to achieve the desired water flow rate.
- Inspect the pump and tubing for obstructions.
- Pump noise can be caused by trapped air, low water level, or the pump being too close to the walls of the fountain. While the pump is fully submerged, try gently tapping the pump with your finger to help release the trapped air. Also, try adding water or moving the pump to help reduce noise.
- If the light is not working, make sure the AC adapter is connected to the light power cable.
- Make sure the power outlet is working; consult a certified electrician when in doubt about electrical connections.

If you experience issues with assembly, pump operation, or the product was damaged during shipping, please contact our customer service team through one of the methods mentioned at the top of page 1.

Please have the item number and order information ready to expedite response time.



IMPORTANT SAFETY INFORMATION



- Fountains may splash or leak; always protect surfaces that can be damaged by water.
- Prevent water loss and damage to electrical sockets by ensuring the power cord has a drip loop; refer to the diagram on the right.
- Keep fountain out of reach of children and pets.
- Make sure the power cord is away from areas where it could be a trip hazard.
- Keep power cord away from all heat sources. Do not use electrical cords in areas with high temperatures.
- Check the water level frequently to ensure the pump remains fully submerged; never allow the pump to run dry as it will burn out the motor.
- Always unplug the power supply before cleaning and maintaining the fountain and the recirculating pump.
- Take care when handling the pump; only pick it up by the body of the pump, never by the power cord.
- Always empty and store the fountain and pump indoors during freezing temperatures.

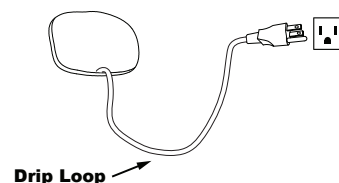

Drawing is for visual reference only, cord placement and plug type vary by fountain style.

Any modification to the product or failure to follow recommended care will void the product warranty.

WARNING:

Manufacturer and seller expressly disclaim any and all liability from personal injury, property damage or loss, whether direct or indirect, or incidental, resulting from the incorrect attachment, improper use, inadequate maintenance, or neglect of this product.