

BC H@G I B @GGC H 9FK -G9 CD97 = 98
%": C F; 9B 9F 5 @9@7 HF 7 5 @A 97 <5B 7 5 @5B 8 9BJ F C BA 9BH5 @
GD97 = 7 5 HC B G G99 G8 &) ! \$\$\$%

.....&" A 5H@F 5 @GD97 = 7 5 HC B G
 6C 8M5B8 7 C I D @B; ' B I H ' G H 5 B @GGG H 9@D9F ' 5 G H A ' 5), &
 B G I @5 H C F . H@: @ C B D 9F ' 5 G H A ' 8 % + % \$
 ; 5 G ? 9 H ' G @ 7 C B ' F I 66 9F ' D 9F ' N N F ! + *)
 F 9 H 5 B . B ; ' F B ; ' 5 B 8 7 C B H 5 7 H 7 C D D 9F ' 5 @ C M

.....": B G < GD97 = 7 5 HC B G
 6C 8M5B8 7 C I D @B; ' B I H ' D 5 G G 7 5 H D 9F ' 5 - * +
 7 C B H 5 7 H ; C @ B D 9F ' 5 G H A ' 6 (, , , ' C J 9F
 B 7 ? 9 @ D 9F ' E E ! B I & - \$ "

.....(" 9 @ 7 H F 7 5 @ GD97 = 7 5 HC B G
 : F 9 E I 9 B 7 M F 5 B ; 9 . \$! & + ; < n "
 J G K F . % \$) - (\$ \$) Z I < n t
 B G 9 F H C B @ C G " \$ ' | √ Z I < n t

.....) " D 7 H C F 5 @ J 9 K ' G D F @ F H C ' 7 F A D B ; ' C D 9 F 5 H C B "

.....* " I G 9 F ; ! (\$) ' f \$,) ' G F E 7 5 6 @ 9 C F ' 9 E I 7 5 @ B H

.....+ " % (+) ' A B A I A ' G F 5 = < H 7 5 6 @ 9 @ B ; H : F 9 E I # 9 8 "

....., " 7 F A D H C ' 7 5 6 @ 1 G B ; ' H M 7 C ' 9 @ 7 H C B 7 G 7 F A D H C @ (% \$) , ') ! %
 5 B J - @ G A 5 # A
 7 F A D @ B ; H : G 9 H B ; . " & \$

.....< C I G B ; ' 7 5 6 @ 9 B H M H C ' 6 9 « " \$, , ' A B A I A ' D F @ F H C ' 7 F A D B ; "

.....% \$ H : G 8 A 9 B G @ C B H C ' 6 9 " & ' \$ Q , (Q 5 : H F 7 F A D B ; "

F9J	8 9 G 7 F D H C B	6M 8 5 H	5 D D 8
5	9 7 F . .) \$	\$ # \$ \$ \$ * DGA	8 7 U a

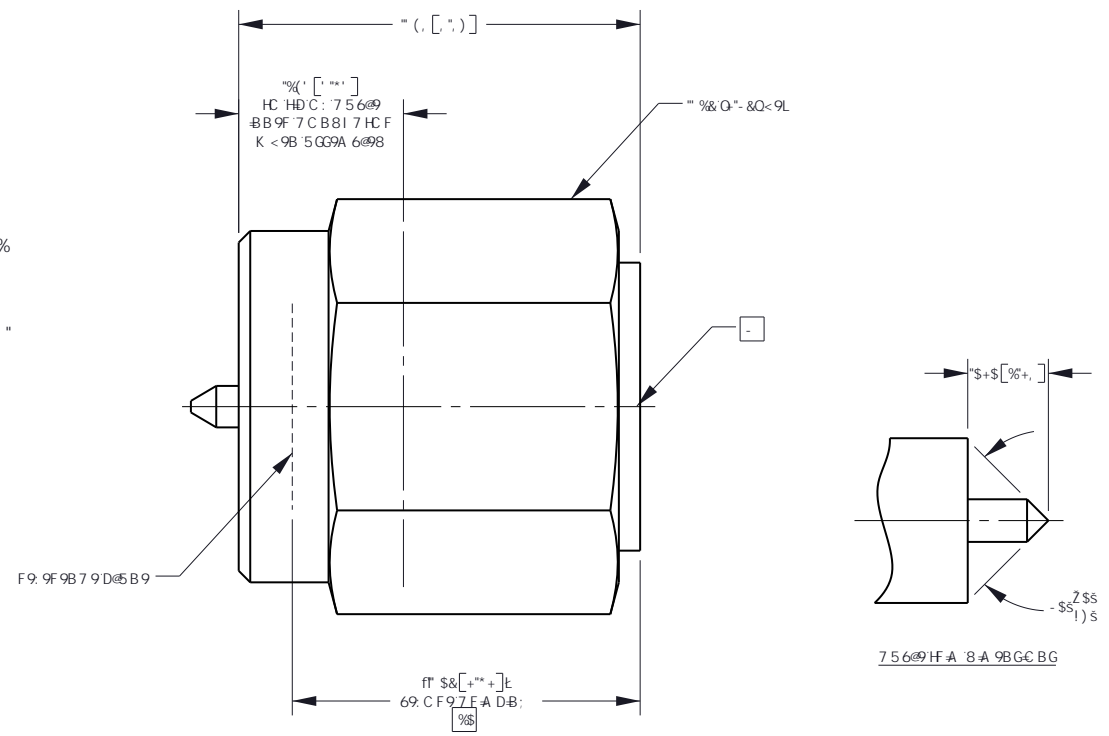

75H5@; D#B. &) \$! - \$\$\$ \$,) \$D

D9F 5 GA 9 M () A 1% - (I B @GGC H 9FK -G9 CD97 = 98, 8 A 9B GC B G 5 F 9 B B 7 < 9 G A A Q HC @F 5 B 7 9 G 8 9 7 A 5 @ " L L - " \$ % Q " O " L L L - " \$ \$) Q % Q " L L L L - " L L L L % G 7 5 @ 9 . * % 5 B : @ G - 8 & / G 7 5 @ 9 . * %		BCFH<FCD; FI A A 5B K] b v X Y g Y f 9 Y W f c b] M g * & 6 U b Y g @ X i g H U F c U X B c H K U] [Z D X 7 H S * (- &	
7 I G C A 9 F 8 F 5 K B ;		GA 5 7 5 6 @ D @ ; 7 C A D F 9 G G C B 7 F A D 5 H 5 7 < A 9 B H	
8 F 5 K B	8 5 H	5 D D F C J 9 8	8 5 H
DGA	\$ + # / # \$	8 7 U a	\$ + # / # \$) #
5 D D F C J 9 8	8 5 H	5 D D F C J 9 8	8 5 H
K DA	\$ & # / # \$ *	H A 7	\$ & # / # \$ * #
5 (G 8 &) \$! - \$\$\$ \$,) \$ D		G < H % C : %	
		F 9 J 5	