

SIDES	BOTTOM
8 1/2" KNOCKOUTS	2 1/2" KNOCKOUTS
4 1/2"-3/4" MOON KNOCKOUTS	2 3/4" KNOCKOUTS
	1 Ground Hump
2 PCS 8-32X1/2 Screws Installed	
Material: Steel-0.0625"-G60 Galvanized	

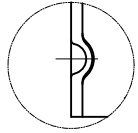

WELDING STYLE DETAIL VIEW D

4 1/2" KNOCKOUTS  $\phi=22.50$  [ $\phi=0.886$ ]

2 1/2"-3/4" MOON KNOCKOUTS  $\phi=22.50$  [ $\phi=0.886$ ]  
 $\phi=28.50$  [ $\phi=1.122$ ]

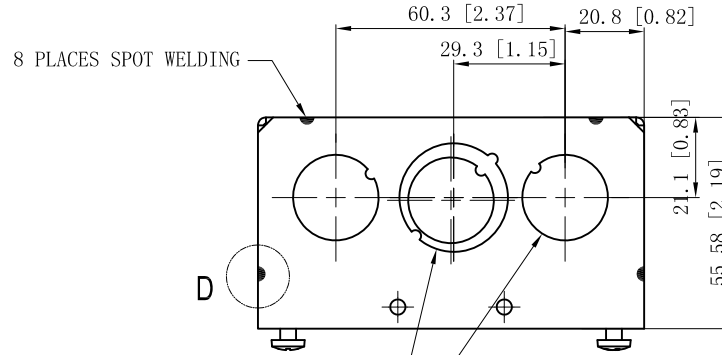
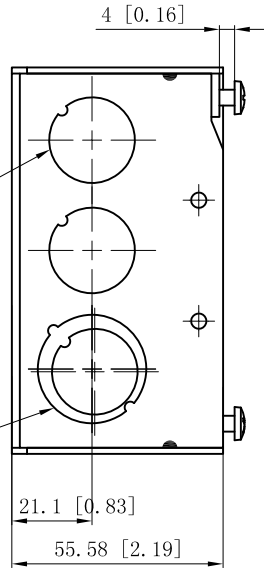

2 1/2"-3/4" MOON KNOCKOUTS  $\phi=22.50$  [ $\phi=0.886$ ]  
 $\phi=28.50$  [ $\phi=1.122$ ]  
 4 1/2" KNOCKOUTS  $\phi=22.50$  [ $\phi=0.886$ ]

2 1/2" KNOCKOUTS  $\phi=22.50$  [ $\phi=0.886$ ]

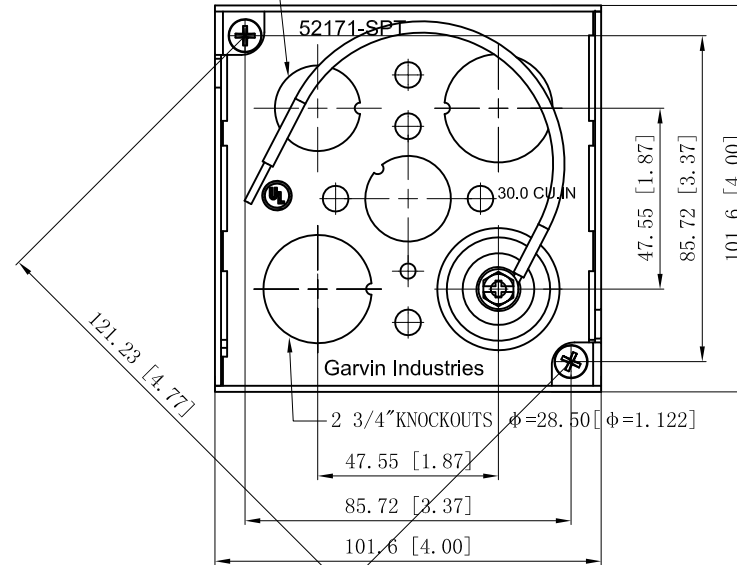

This data sheet is for reference only. GARVIN INDUSTRIES reserves the right to make changes to the design without prior notice.

DESCRIPTION
TRADE REFERENCE TERMS

STANDARD PACKING
25 PCS

<b>GARVIN INDUSTRIES</b>	
TITLE 4" SQUARE BOXES 2-1/8" DEEP	
SIZE A4	DWG NO. 52171-SPT
DATA SHEET	
REV A	