



INSTRUCTIONS FOR ASSEMBLING A TORNADO SLIDE



ASSEMBLING A TORNADO SLIDE

SLIDE PART DESCRIPTIONS

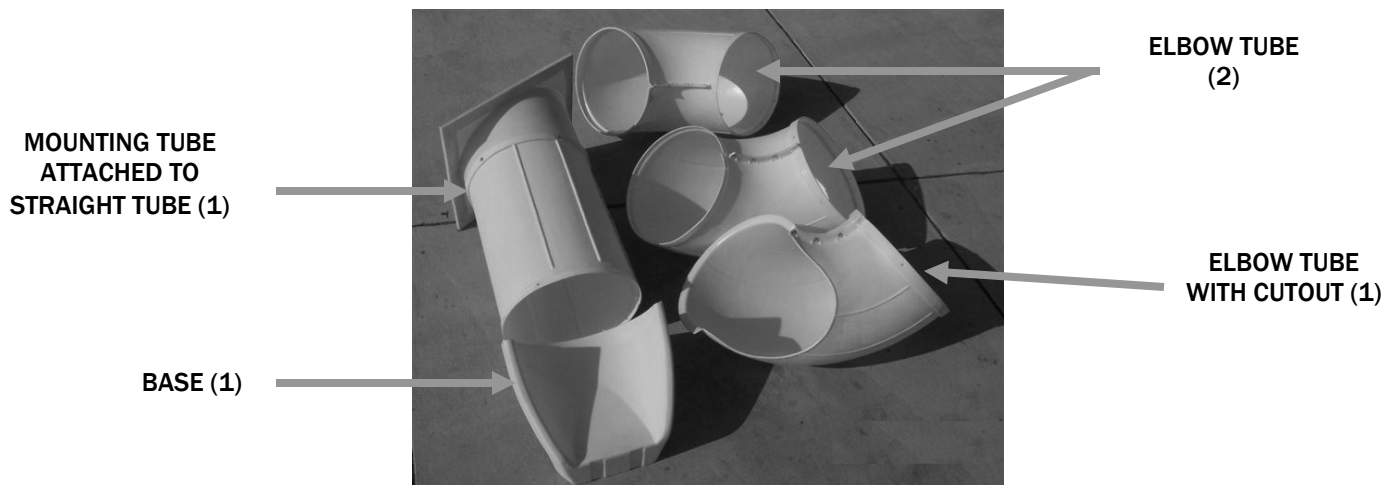

HARDWARE LIST (HWBAG-TORNADO)

ITEM#	PART #	DESCRIPTION	QUANTITY
A	HWLS5/16X3S	5/16" X 3" LAG SCREW SS	8
B	HWLS5/16X1 3/4S	5/16" X 1 3/4" LAG SCREW SS	5
C	HWBSC5/16X1S	5/16" X 1" BUTTON SOCKET SS	10
D	HWBSC5/16X7/8S	5/16" X 7/8" BUTTON SOCKET SS	21
E	HWMB5/16X1S	5/16" X 1" MACHINE BOLT SS	4
F	HWMB5/16X3/4S	5/16" X 3/4" MACHINE BOLT SS	14
G	HWW5/26STDSS	5/16" STD WASHER SS	112
H	HWN5/16LOCS	5/16" LOC NUT SS	50

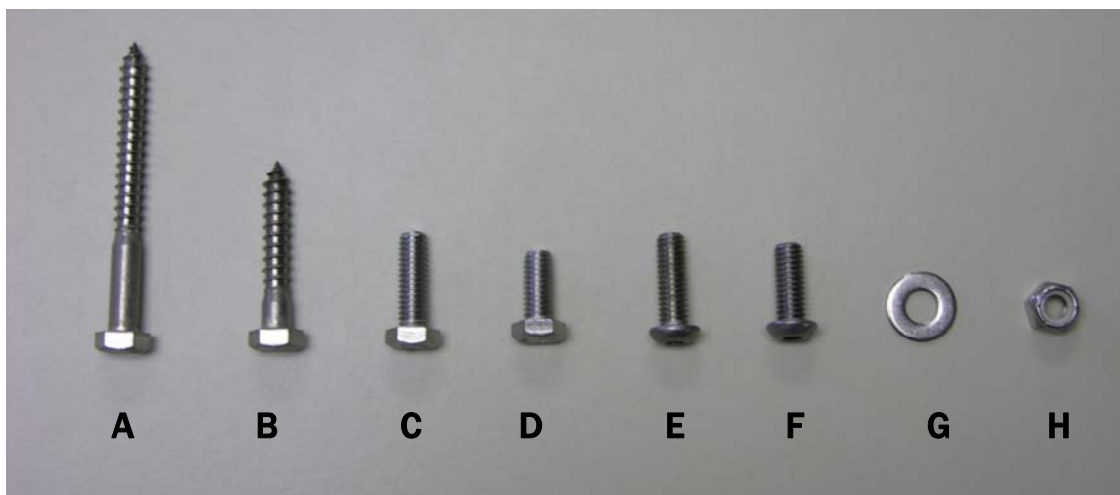

HARDWARE IDENTIFICATION

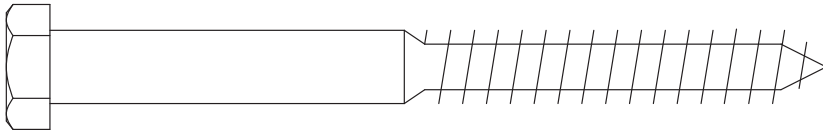

LS4 (3/8" X 4" Lag Screw)

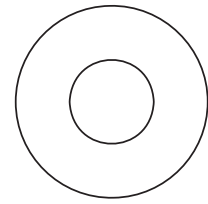

FW2 (3/8" Standard Flat Washer)

STANDARD PARTS LIST

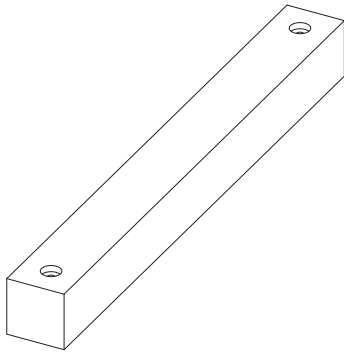

RW-4X4-031-FIL
31" Vertical Filler

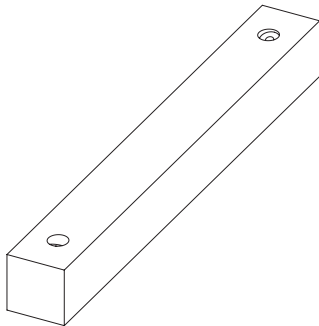

28-1/2" Ladder Filler
RW-4X4-029-FIL

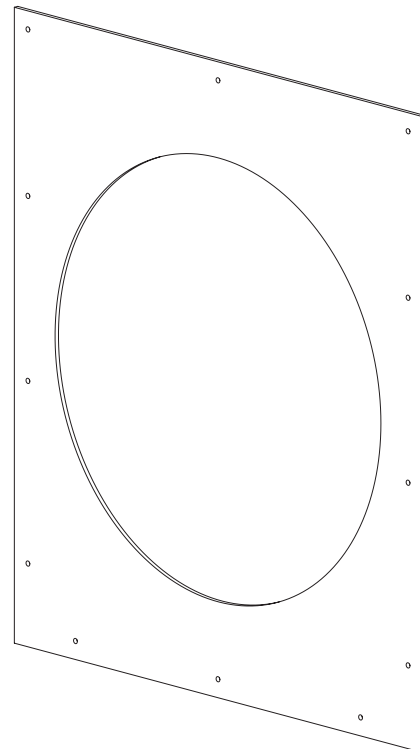

Bubble Mounting Plate
PL-BMP-035-030

STEP 1

Filler Installation for Tornado Slide and Bubble Panel

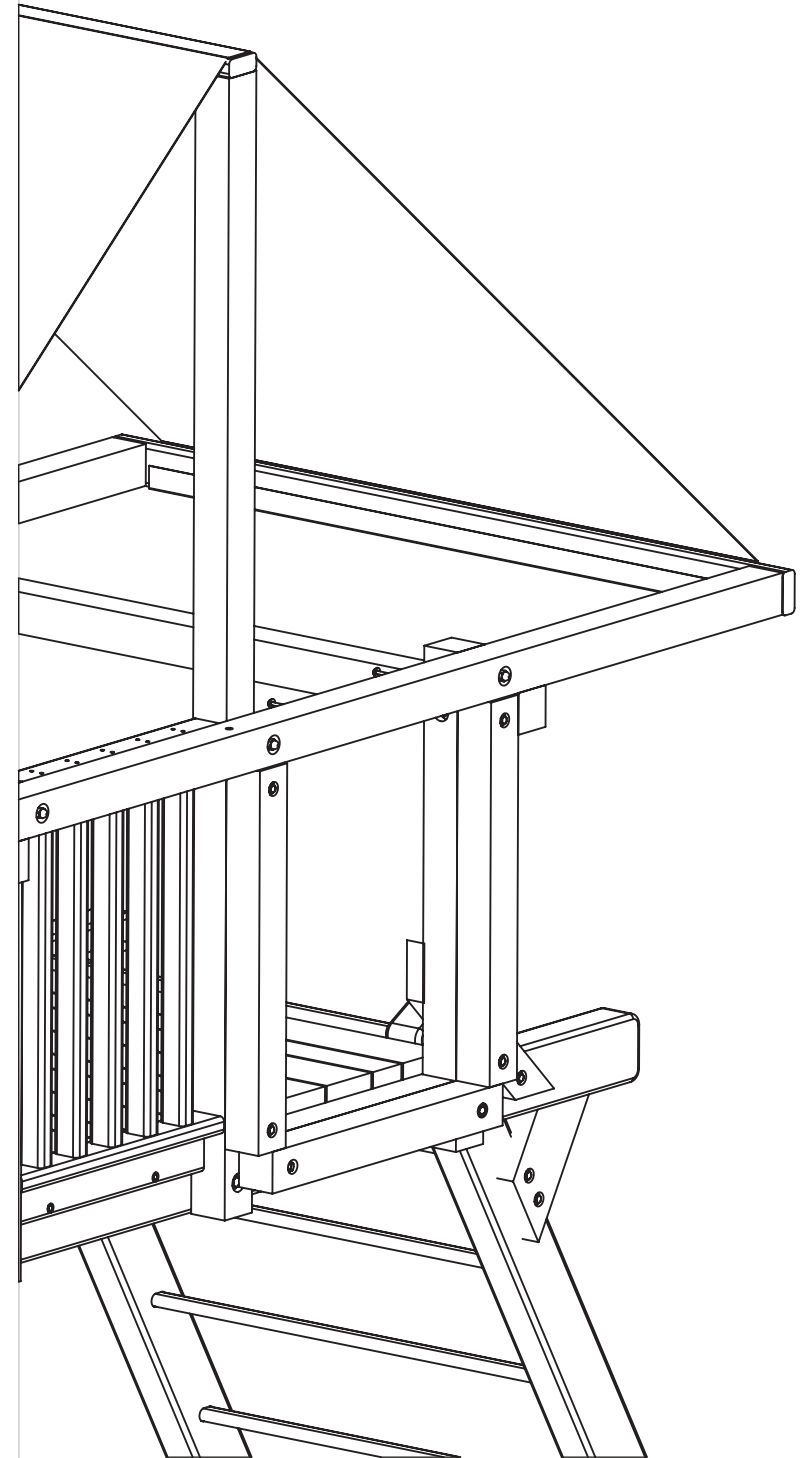
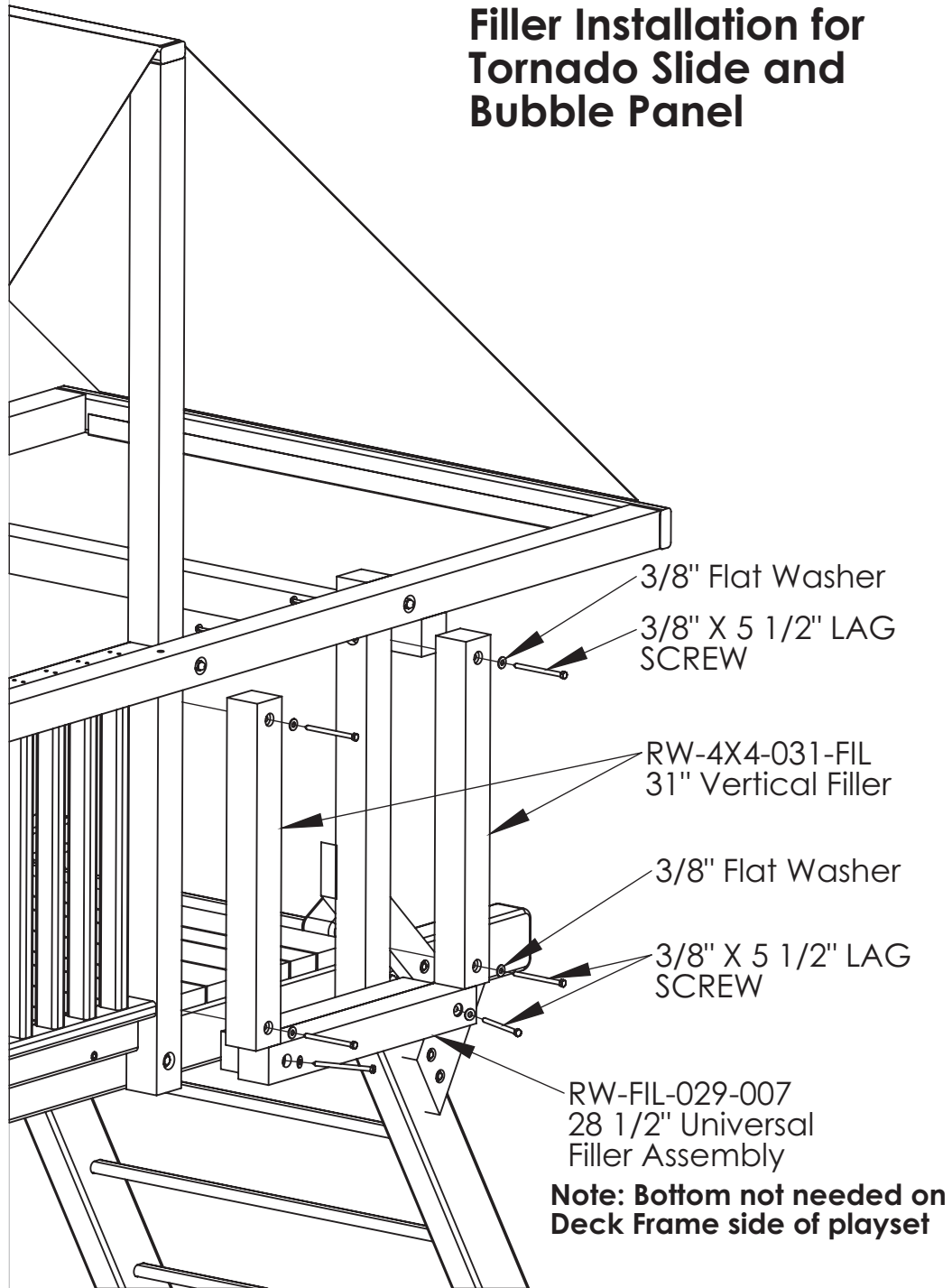

STEP 2 - BUILD TUBE SECTIONS

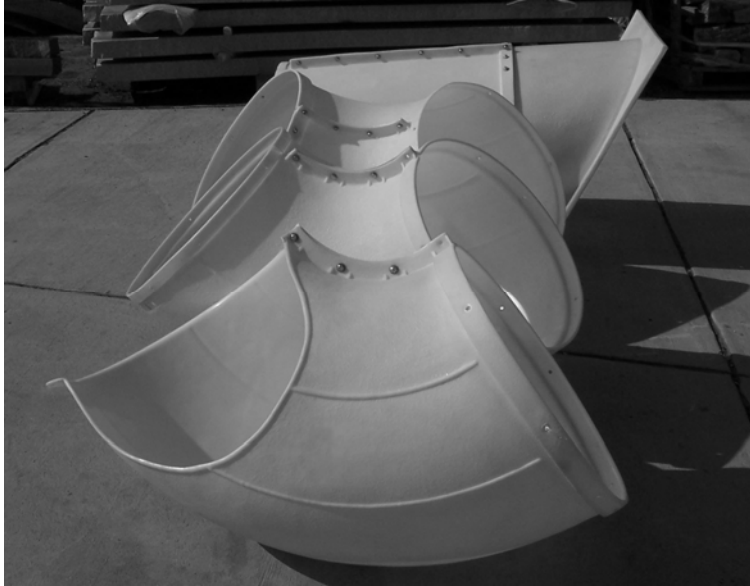

Connect the flanges of each tube section to make 3 elbows. Use $7/8$ " Hex Head Machine Bolts in 3 holes. In the fourth hole (the hole closest to female end), use a 1" Hex Head Machine bolt. Place a washer on each side with a $5/16$ " Loc nut to secure the bolts. Repeat this step for the straight tube.
Do not tighten bolts at this time.

STEP 3 - ATTACH MOUNTING TUBE TO STRAIGHT TUBE



Stand up the Straight Tube with the female end up and insert the Mounting Tube. (You may need to temporarily remove the end bolt in the flange) Align the flange of the Straight Tube and the seam on the long side of the Mounting Tube. Tighten the bolts in the flange to hold the sections in place.

Using a 5/16" drill bit and the predrilled holes as a guide, from the outside, drill through the slide. From the inside of the slide insert a 1" Button Head Cap Screw with a washer and secure it on the outside with a washer and Loc nut. Repeat for the remaining holes and tighten all bolts in the Step 2 Assembly.

STEP 4 - ATTACH THE STEP 2 ASSEMBLY TO THE PLAYSET PANEL



With a helper hold the Mounting Tube up against the playset tornado panel and align all sides with the panel. Attach using the 3" lag screws and washers.

STEP 5 - ATTACH AN ELBOW TUBE WITH THE STRAIGHT TUBE



Insert an elbow tube (without the cutout) onto the straight tube. (You may need to temporarily remove the end bolt in the flange). Align the #1 on the elbow tube with the #1 on the straight tube. Tighten the bolts in the flange to hold the sections in place. Using a 5/16" drill bit and the predrilled holes as a guide, drill through the slide from the outside. From the inside of the slide insert the 7/8" Button Head Cap Screw with a washer and secure it on the outside with a washer and Loc nut. Repeat for the remaining holes and tighten all bolts in the Step 3 assembly.

STEP 6 - ATTACH ANOTHER ELBOW TUBE AND ALIGN THE BASE



Insert another elbow tube (without the cutout) onto the first elbow tube (You may need to temporarily remove the end bolt in the flange). **Do not attach the elbow tube at this time.** Insert the third elbow tube (with the cutout) onto the second elbow tube. Place the base at the bottom. Rotate the two sections until the desired height is achieved at the base. Depending on the deck height, the markings on the tube should be close to #1 at a 6' deck height and #2 at a 7' deck height. When the desired setting is reached, drill a hole through the second elbow tube and insert a Button Head Cap Screw from the outside to hold it in place.

Remove the last elbow tube and finish drilling the holes in the second elbow tube. From the inside, attach with the 7/8" Button Head Cap Screw, place a washer on both sides and secure on the outside with a Loc Nut.

STEP 7 - ATTACH THE LAST ELBOW TUBE



Insert the third elbow tube (with the cutout) onto the second elbow tube. (You may need to temporarily remove the end bolt in the flange). Place the base at the bottom and rotate the third elbow tube to its desired location making sure it fits snugly in the rim of the base. Drill a hole through the elbow and insert a Button Head Cap Screw from the outside to hold it in place. Finish drilling all holes and attach from the inside with 7/8" Button Head Cap Screws, place washers on both sides and secure with Loc Nuts. Tighten all bolts in this step.

STEP 8 - ATTACH THE BASE



Place the base under the last elbow tube. Adjust so the elbow tube fits snugly into the rim of the base. Drill (5) $1/8$ " tap holes through the last elbow and into the base, evenly spaced around the rim. Attach using the $5/16$ " x $1\ 3/4$ " Lag Screws with Washers.

Note: Be careful not to over tighten the lag screws.