

B E R N H A R D T



Assembly Instructions

Forsyth Desk

Model # : D16-514

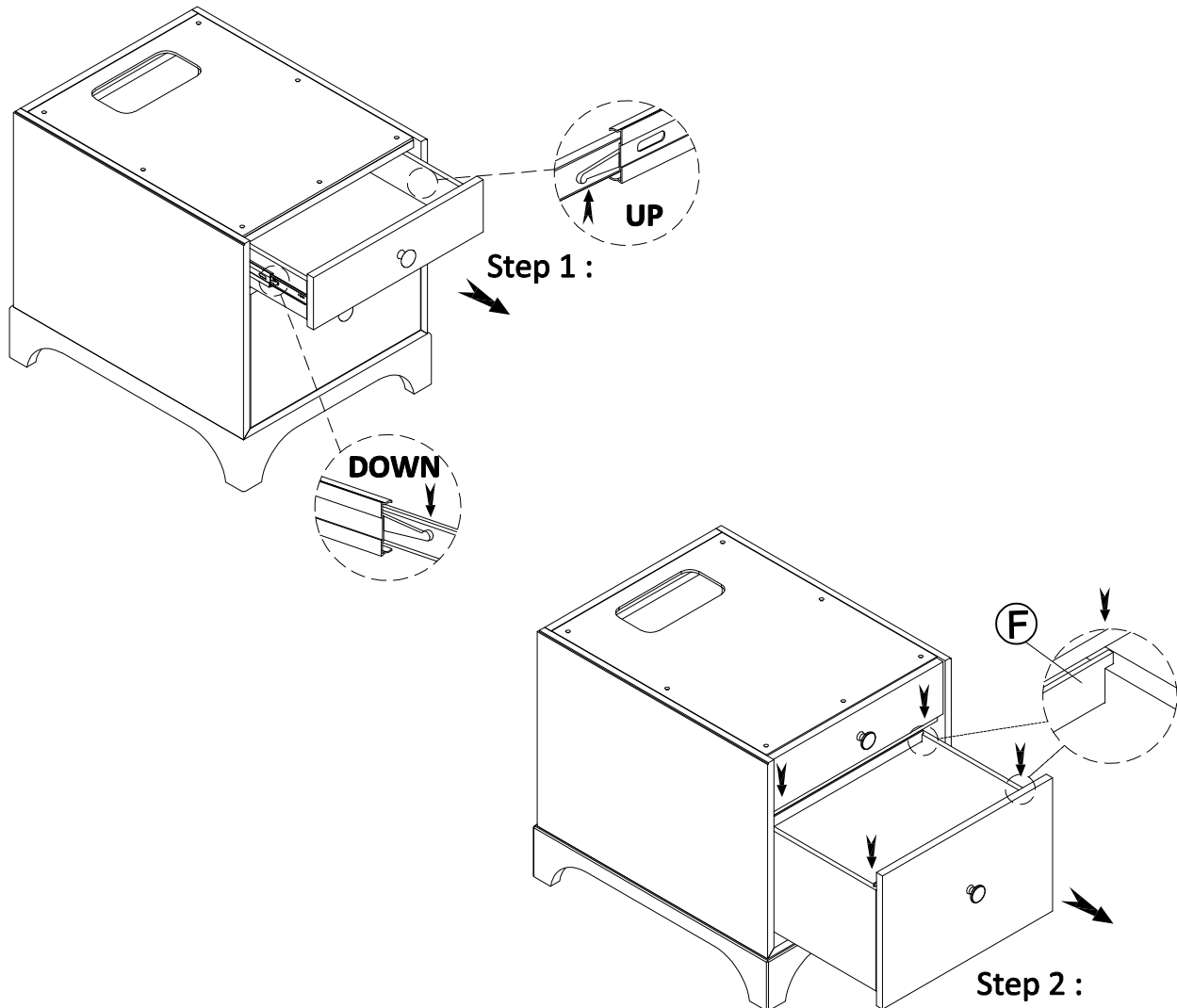
Thank you for purchasing Bernhardt furniture . Please check all packing material to ensure proper assembly. Please read all instructions carefully before starting the assembly process . Some parts are large and heavy and require AT LEAST TWO PEOPLE to assemble , in order to prevent possible injury and / or damage to the piece



No.	Hardware List		Q'ty
A		Flat Washer $\varnothing 5/16"$ x $\varnothing 18$ x1mm	16
B		Lock Washer $\varnothing 1/16"$ x $\varnothing 14$ x1mm	16
C		Bolt $\varnothing 5/16$ xL1-1/2" ($\varnothing 14$)	16
D		Allen Wrench 4mm	1
E		Tipping restraint	1
F		File Hanger Bar	4

Cleaning instruction: Wipe surface to be cleaned with damp cotton cloth ; dry immediately with soft dry cotton cloth to remove all moisture .

Thank you for purchasing Bernhardt furniture . Please check all packing material to ensure proper assembly. Please read all instructions carefully before starting the assembly process . Some parts are large and heavy and require AT LEAST TWO PEOPLE to assemble , in order to prevent possible injury and / or damage to the piece

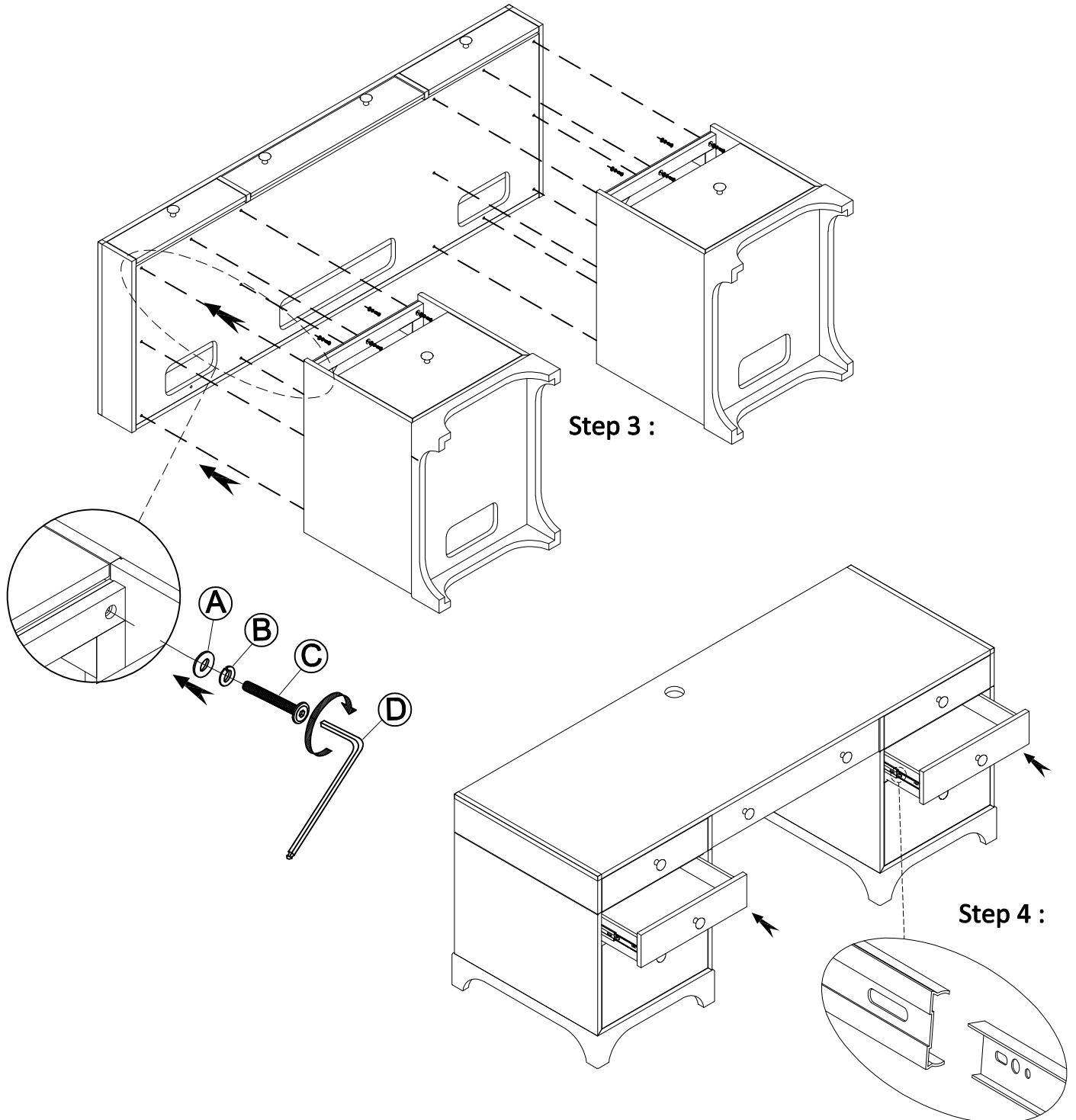

Cleaning instruction: Wipe surface to be cleaned with damp cotton cloth ; dry immediately with soft dry cotton cloth to remove all moisture .

Thank you for purchasing Bernhardt furniture . Please check all packing material to ensure proper assembly. Please read all instructions carefully before starting the assembly process . Some parts are large and heavy and require AT LEAST TWO PEOPLE to assemble , in order to prevent possible injury and / or damage to the piece

Please, refer to the tip restraint's instruction for proper installation

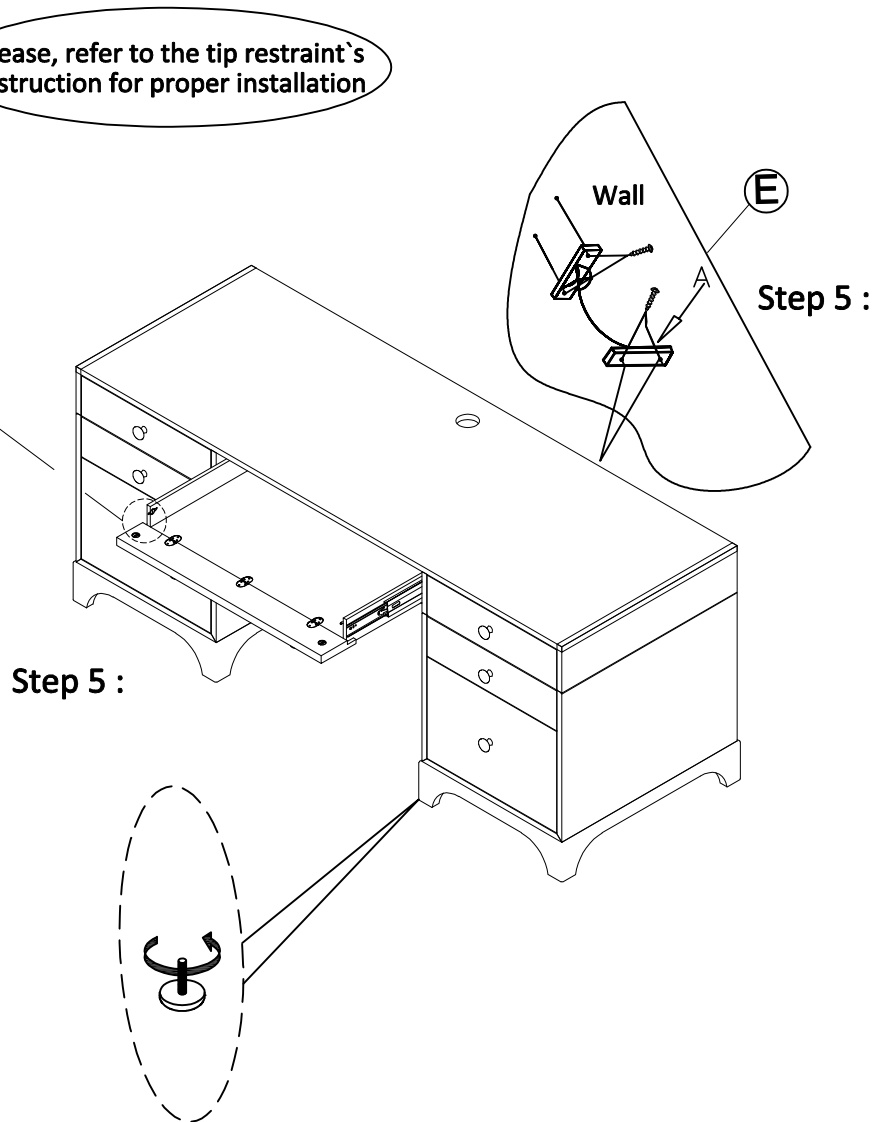
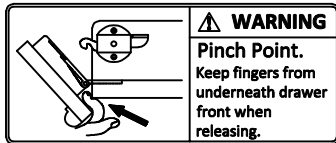

Cleaning instruction: Wipe surface to be cleaned with damp cotton cloth ; dry immediately with soft dry cotton cloth to remove all moisture .