

ASPEN / TRISHA / BARNEY

SIDE TABLE

MODEL # AXCASP-C04

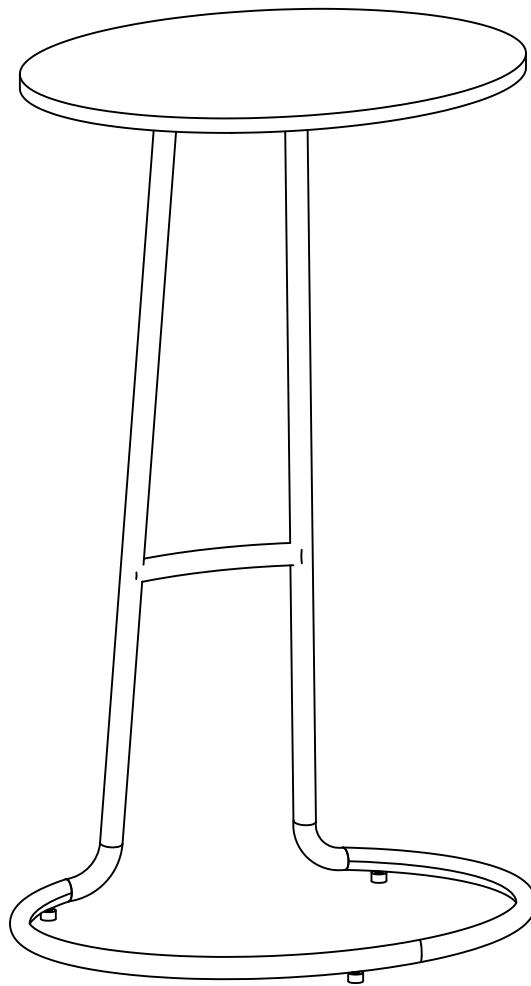

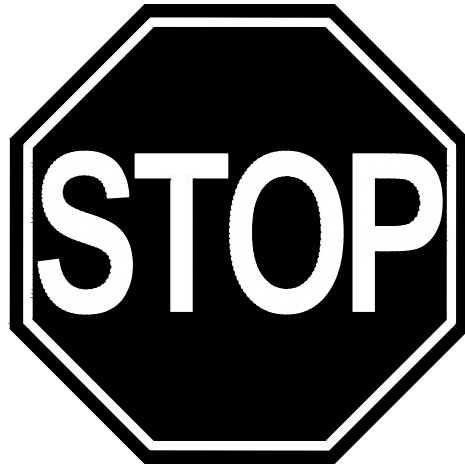

Questions, problems, assembly help, missing parts?

No need to return the product, we will gladly help and ship your replacement parts free of charge

Please call Customer Service at 1-866-518-0120 ext. 262

Monday to Friday between 9 am –4 pm EST

or go to

www.simpli-home.com/parts request

In order to assist you in a timely manner, please have the following information ready:

Model # _____ Part Number or Letter _____

Purchased at _____ Date of Purchase _____

If you wish to return the product, please contact the retailer where the product was purchased.

IMPORTANT : Keep this manual for future reference.

CARE and MAINTENANCE

This furniture is designed for indoor use.

Marble tops are factory polished to a smooth gloss finish and are sealed for added protection. In order to maintain the surface and keep it looking fresh and natural, we recommend the following procedures:

- For regular cleaning, use a damp cloth with warm water, rinse and dry thoroughly to prevent streaks.
- Wipe off any spills immediately.
- Never use abrasive cleaners or rough cleaning pads. These types of cleaners can etch or dull stone surfaces. If necessary, a soft buffing pad can be used.

To help protect your metal furniture, follow these steps:

- Use a humidifier, preferably one with an automatic control system that can sense the humidity level and adjust itself accordingly.
- Dust with soft dry cloth.
- Wipe up spills promptly. Clean with a dry cloth.
- Do not use abrasive cleaners, chemical solvents, strong detergents, cleaners with bleach, and furniture polish.
- Use soft felt base coasters, placemats to help prevent scratches.
- Keep furniture out of direct sunlight, which can cause cracking or roughness on the protective layer.
- If it can be avoided, do not put furniture near heating vents. Keep the furniture 3 to 4 inches away from the wall, giving heat and air space to circulate.

PRE-ASSEMBLY INFORMATION

MODEL # AXCASP-C04

PARTS DESCRIPTION

A

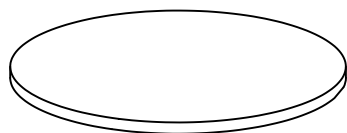

TOP
QTY 1

B

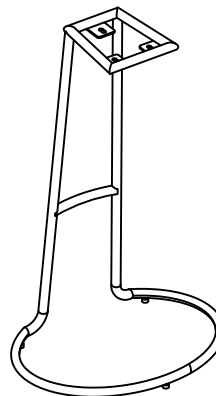

BASE
QTY 1

PRE-ASSEMBLY INFORMATION

MODEL # AXCASP-C04

HARDWARE DESCRIPTION

1

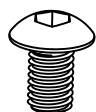

ALLEN KEY BOLT
M6 X 15 mm
QTY 3

2



WASHER
Ø 17 / Ø 6.5 X 1.0 mm
QTY 3

3



LOCK WASHER
Ø 10 / Ø 6.5 X 2.0 mm
QTY 3

4



ALLEN KEY
QTY 1

NEED HELP? for help with assembly or if you are missing a part,
Please call customer service at 1-866-518-0120 ext. 262 (9 am to 4 pm est)

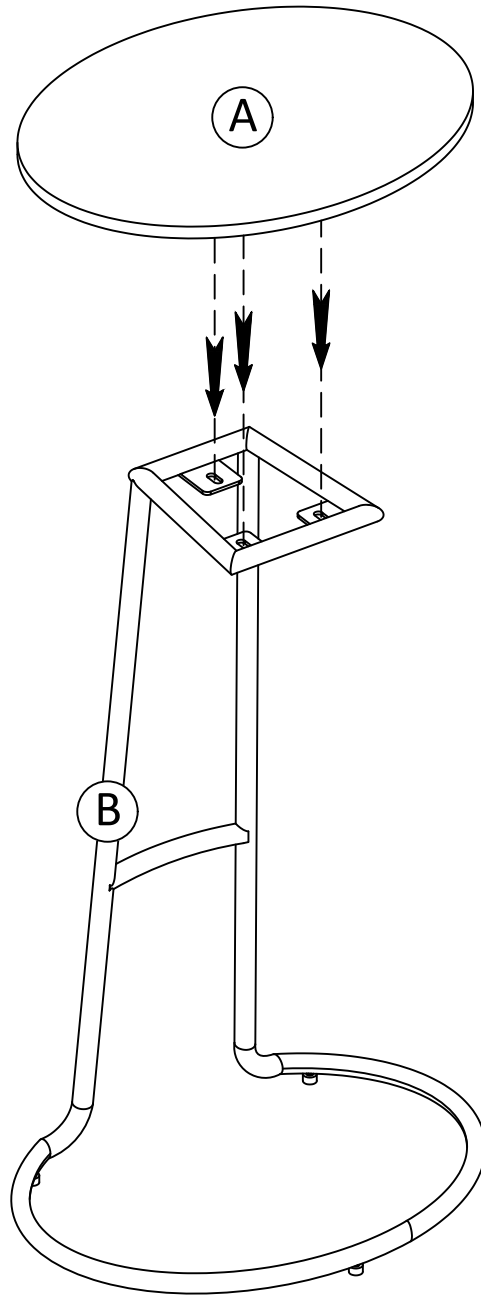

STEP 1

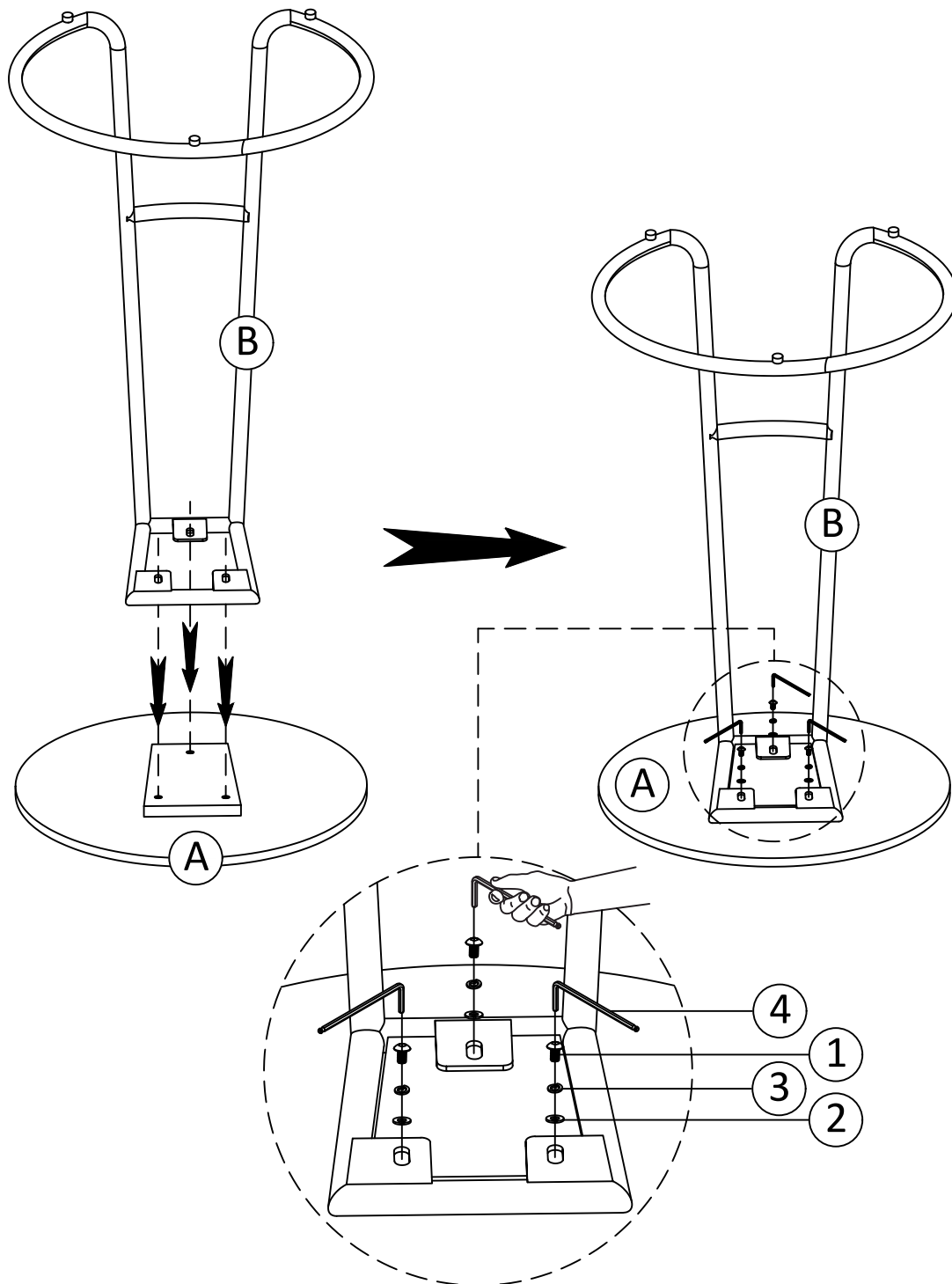

1. Place the Top (A) upside on a flat smooth surface.
2. Place the Base (B) on the Top (A) and align the holes.
3. Use three Allen Key Bolts (1), three Washers (2) and three Lock Washers (3) to attach Top (A) and Base (B).
4. Use Allen Key (4) to tighten Bolts. Do not over tighten.

STEP 2

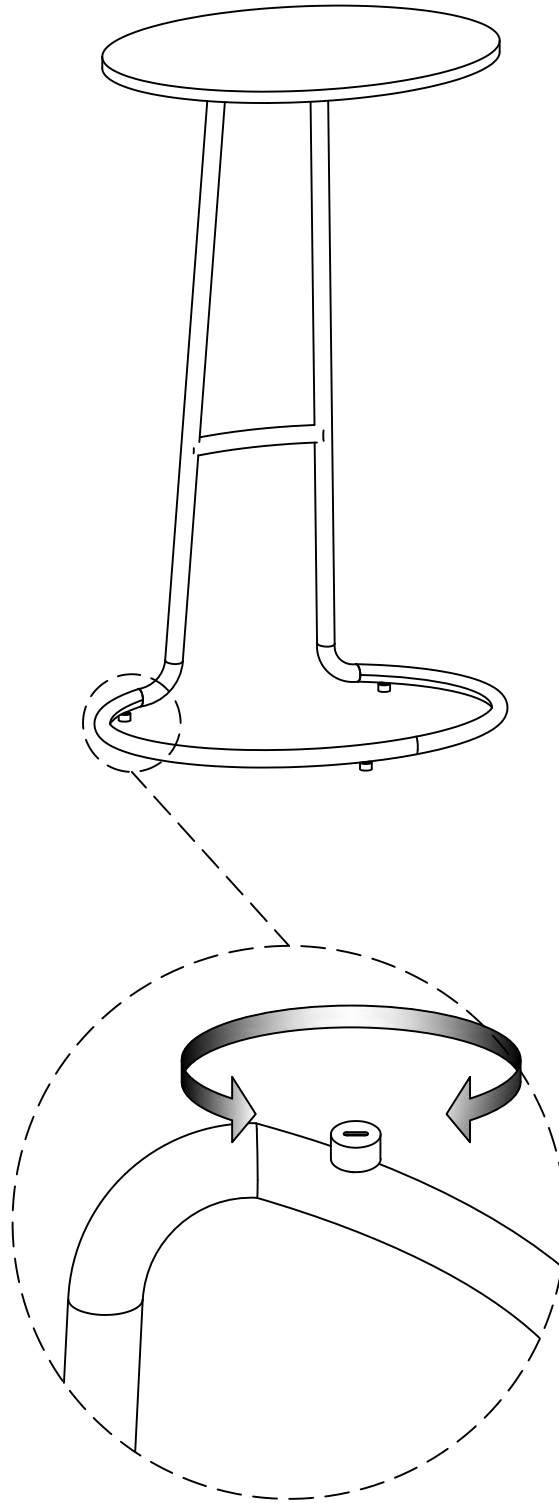

Note: Levelers underneath the base can be adjusted if floor is uneven.



WARRANTY

Thank you for purchasing a **Simpli Home – Wyndenhall – Brooklyn + Max** product. These products have been made to demanding, high-quality standards and are guaranteed for domestic use against manufacturing faults for a period of 12 months from the date of purchase. This warranty does not affect your statutory rights.

In case of any malfunction of your product (failure, missing parts, etc.) please contact us at our toll free service line at 1-866-518-0120 ext. 262 from 9 am to 4 pm, Monday to Friday, Eastern Standard Time or by email at customerservice@simpli-home.com

We reserve the right to repair or replace the defective product, at its discretion.

This product is guaranteed for 12 months if used for normal purposes. Any warranty is invalid if the product has been overloaded or subject to neglect, improper use or an attempted repair by other than an authorized agent. Heavy-duty or daily professional/commercial usage are not guaranteed.

Due to continuous product improvement, we reserve the right to change the product specifications without prior notice.