

A

B

C

D

E

F

REVISIONS

| REV. | DESCRIPTION | DATE | APPROVED |
|------|-----------------------|------------|----------|
| A | INITIAL RELEASE | 12/02/2004 | |
| B | STUD BALL DIA REVISED | 04/08/2005 | |
| C | REVISED PART (700883) | 1/14/2013 | |

1

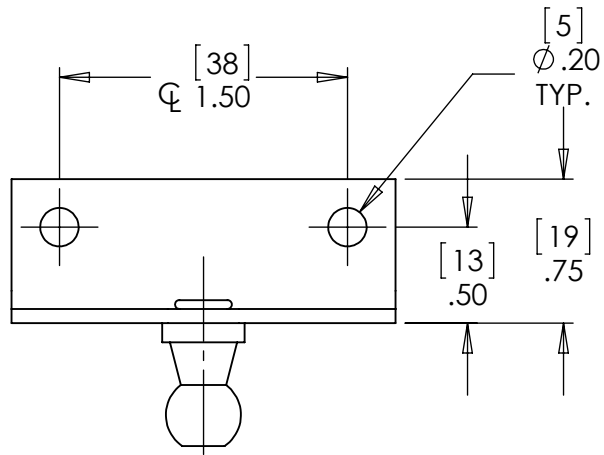

2

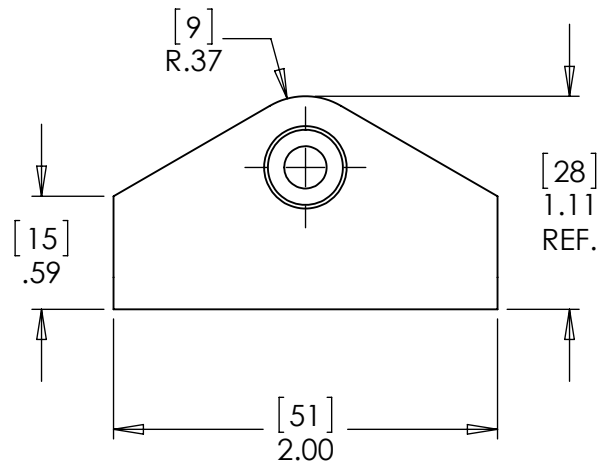

3

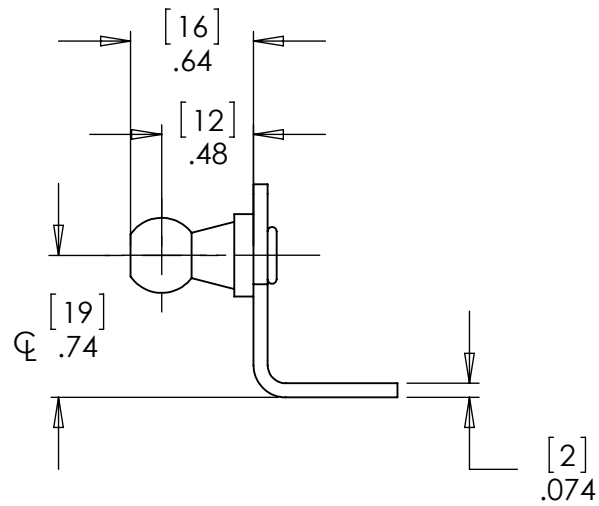

4

NOTES:

- ALL DIMENSIONS ARE IN INCHES [MILLIMETERS]
- MATERIAL: STEEL
- FINISH: BRIGHT ZINC PLATE

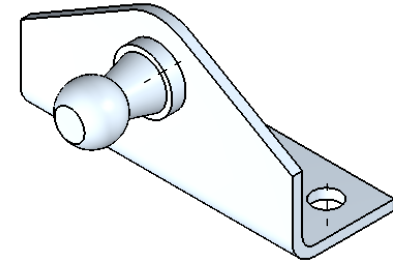

1

2

3

4

THE INFORMATION CONTAINED IN THIS DRAWING IS THE SOLE PROPERTY OF TRANS CONTINENTAL HARDWARE. ANY REPRODUCTION IN PART OR AS A WHOLE WITHOUT THE WRITTEN PERMISSION OF TRANS CONTINENTAL HARDWARE IS PROHIBITED.

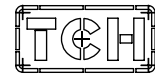

TRANS CONTINENTAL HARDWARE

PART NAME **10MM - 2-HOLE RT BRACKET**MATERIAL **STEEL**DRAWING NO. **530-100800**

REVISION NO.

DATE **12/2/2004** SCALE **1:1** THIRD ANGLE PROJECTION DRAWING

ALL DIMENSIONS WITHOUT TOLERANCES ARE REFERENCE

SPECIFICATION SUBJECT TO CHANGE WITHOUT NOTICE

A

A

B

C

D

E

F