



Project Name: \_\_\_\_\_

Location: \_\_\_\_\_

Item #: \_\_\_\_\_ Qty: \_\_\_\_\_

Model: \_\_\_\_\_

# MEGA TOP SALAD/SANDWICH PREP TABLES

MODEL:  GRSLM-2D



Grista's Mega Top Salad/Sandwich Prep Tables are constructed of heavy duty stainless steel making them strong and durable enough to survive in any kitchen environment. Store all of your condiments, meats and vegetables in the cold topping area that can hold a variety of different sized food pans up to 6" deep. The oversized hinged insulated cover keeps the food items cold when not in service. Store additional items below in the cabinet for quick access when needed. All salad/sandwich prep tables come with 4" casters, plastic coated wire shelving and a 3/4" thick polyethylene cutting board. These models are ETL Listed and ETL Sanitation. They are backed with a 2 year warranty on parts and labor and a 5 year warranty on the compressor.

## FEATURES AND CONSTRUCTION

- 430 series stainless steel exterior
- Painted aluminum interior
- Environmentally-friendly R290 refrigerant
- Precise digital temperature controller with LED display
- Foamed-in-place polyurethane high density cell insulation throughout the entire cabinet
- Oversized hinged insulated lid
- Removable door gasket
- Recessed door handles
- 3/4" thick removable polyethylene cutting board
- Clear plastic food pans included
- (4) 4" casters (2 locking and 2 non-locking)

## ELECTRIC

115V / 60Hz / 1Ph  
7' (2.1m) NEMA 5-15P cord set included

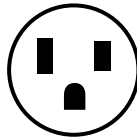

NEMA 5-15P

## 3RD PARTY APPROVALS



Intertek



Intertek

## NOMINAL STORAGE CAPACITY

GRSLM-2D ..... 12 Cu Ft (340 L)

## TEMPERATURE

Holding Temperature ..... 33°F to 41°F (1°C to 5°C)

- These models are designed to operate in an environment where temperature and humidity do not exceed 75°F (24°C) and 55% relative humidity

## GRISTA WARRANTY (USA / CANADA)

Contact Admiral Craft for warranty statement at [info@admiralcraft.com](mailto:info@admiralcraft.com) or 516.433.3535

# MEGA TOP SALAD/SANDWICH PREP TABLES

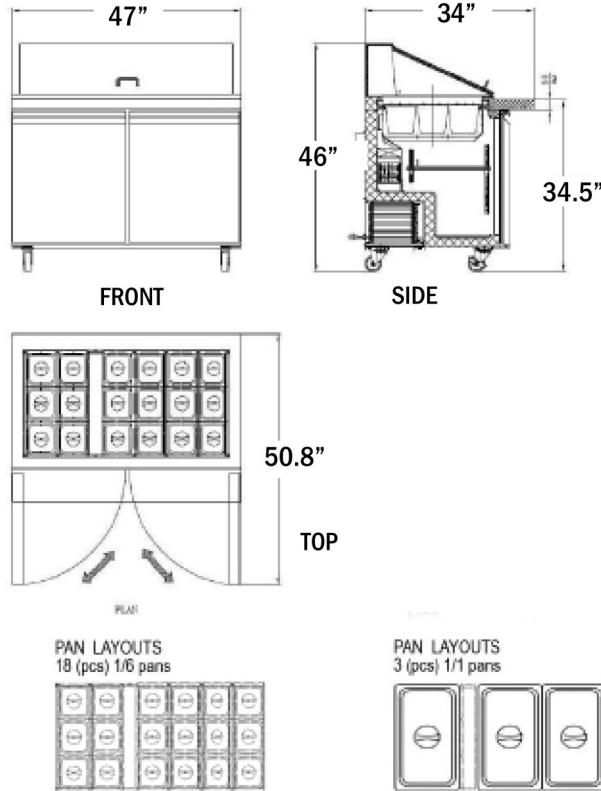

Model Number	GRSLM-2D
Doors	2
Shelves	2
Net Volume (Cu. Ft.)	12 Cu. Ft
Overall Dimensions (in)	47"L x 34W" x 46"H
Interior Dimensions (in)	43"L x 24"W x 24"H
Horsepower	1/4+
Refrigerant	R290
Voltage/Hertz/Phase	115/60/1
Amps	6.1
Net Weight (lbs)	282 lbs
Gross Weight (lbs)	407 lbs
Shipping Dimensions (in)	51"L x 34"W x 49"H