

# TWIN MOUNTAIN LODGE – F25700X

## INSTALLATION AND OPERATING INSTRUCTIONS

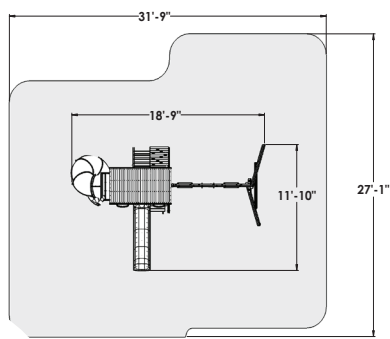

### WARNING

To reduce the risk of serious injury or death, you must read and follow these instructions. Keep and refer to these instructions often and give them to any future owner of this play set. Manufacturer contact information provided below.

OBSTACLE FREE SAFETY ZONE - 31' 9" x 27' 1" (9.67 x 8.23 m) area requires Protective Surfacing. See page 3.

MAXIMUM VERTICAL FALL HEIGHT - 6' 7" (2.01 m)

CAPACITY - 12 Users Maximum, Ages 3 to 10; Weight Limit 110 lbs. (49.9 kg) per child.

RESIDENTIAL HOME USE ONLY. Not intended for public areas such as multi-unit residences, schools, churches, nurseries, day cares or parks.

Warning. Only for domestic use.

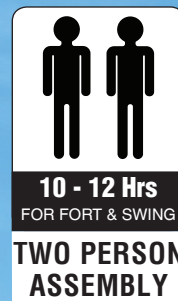
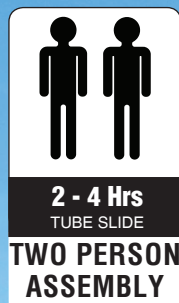

KidKraft, Inc.  
4630 Olin Road  
Dallas, Texas 75244 USA  
customerservice@kidkraft.com  
canadacustomerservice@kidkraft.com  
1.800.933.0771  
972.385.0100  
For online parts replacement visit  
<https://parts.kidkraft.com/>

KidKraft Netherlands BV  
Olympisch Stadion 29  
1076DE Amsterdam  
The Netherlands  
europecustomerservice@kidkraft.com  
+31 20 305 8620 M-F from 09:00 to 17:30  
(GMT+1)  
For online parts replacement visit  
<https://parts.kidkraft.eu/>

### Table of Contents

Warnings and Safe Play Instructions.....	pg. 2
Protective Surfacing Guidelines.....	pg. 3
Instructions for Proper Maintenance.....	pg. 4
About Our Wood – Limited Warranty.....	pg. 5
Keys to Assembly Success.....	pg. 6
Part ID.....	pg. 8
Step-By-Step Instructions.....	pg. 18
Installation of I.D./Warning Plaque.....	Final Step
9405700X	Rev 06/11/2019

# Warnings and Safe Play Instructions



**CONTINUOUS ADULT SUPERVISION REQUIRED.** Most serious injuries and deaths on playground equipment have occurred while children were unsupervised! Our products are designed to meet mandatory and voluntary safety standards. Complying with all warnings and recommendations in these instructions will reduce the risk of serious or fatal injury to children using this play system. Go over the warnings and safe play instructions regularly with your children and make certain that they understand and follow them. Remember on-site adult supervision is required for children of all ages.



## WARNING

### SERIOUS HEAD INJURY HAZARD

Installation over concrete, asphalt, dirt, grass, carpet and other hard surface creates a risk of serious injury or death from falls to the ground. Install and maintain shock absorbing material under and around play-set as recommended on page 3 of these instructions.

### COLLISION HAZARD

Place play-set on level ground at least 2m from any obstruction such as a garage or house, fences, poles, trees, sidewalks, walls, landscape timbers, rocks, pavement, planters, garden borders, overhanging branches, laundry lines, and electrical wires. (See OBSTACLE FREE SAFETY ZONE on cover)

### CHOKING HAZARD/SHARP EDGES & POINTS

Adult assembly required. This product contains small parts and parts with sharp edges and points. Keep parts away from children until fully assembled.

### WARNING LABEL

Owners shall be responsible for maintaining the legibility of the warning labels.

### STRANGULATION HAZARD

- NEVER allow children to play with ropes, clotheslines, pet leashes, cables, chains or cord-like items when using this play-set or to attach these items to play-set.
- NEVER allow children to wear loose fitting clothing, ponchos, hoods, scarves, capes, necklaces, items with draw-strings, cords or ties when using this play-set.
- NEVER allow children to wear bike or sport helmets when using this play-set.

Failure to prohibit these items, even helmets with chin straps, increases the risk of serious injury and death to children from entanglement and strangulation.

### TIP OVER HAZARD

Choose a level location for the equipment. This can reduce the likelihood of the play set tipping over and loose-fill surfacing materials washing away during heavy rains.

DO NOT allow children to play on the play-set until the assembly is complete and the unit is properly anchored.

Never add extra length to chain or rope. The chains or ropes provided are the maximum length designed for the swinging element(s).



## WARNING – Safe Play Instructions

- ✓ Observe capacity limitations of your play-set. See front cover.
- ✓ Dress children with well fitting and full foot enclosing footwear.
- ✓ Teach children to sit with their full weight in the center of the swing seat to prevent erratic swing motion or falling off.
- ✓ Check for splintered, broken or cracked wood; missing, loose, or sharp edged hardware. Replace, tighten and or sand smooth as required prior to playing.
- ✓ Verify that suspended climbing ropes, rope ladders, chain or cable are secured at both ends and cannot be looped back on itself as to create an entanglement hazard.
- ✓ On sunny and or hot days, check the slide and other plastic rides to assure that they are not very hot as to cause burns. Cool hot slide and rides with water and wipe dry prior to using.
- ✓ Orientate slide such that it gets the least amount of exposure to the sun.
- ✗ Do not allow children to wear open toe or heel footwear like sandals, flip-flops or clogs.
- ✗ Do not allow children to walk, in front, between, behind or close to moving rides.
- ✗ Do not let children twist swing chains or ropes or loop them over the top support bar. This may reduce the strength of the chain or rope and cause premature failure.
- ✗ Do not let children get off rides while they are in motion.
- ✗ Do not permit climbing on equipment when it is wet.
- ✗ Do not permit rough play or use of equipment in a manner for which it was not intended. Standing on or jumping from the roof, elevated platforms, swings, climbers, ladders or slide can be dangerous.
- ✗ Do not allow children to swing empty rides or seats.
- ✗ Do not allow children to go down slide head first or run up slide.



# ⚠️ Protective Surfacing - Reducing Risk of Serious Head Injury From Falls.

One of the most important things you can do to reduce the likelihood of serious head injuries is to install shock-absorbing protective surfacing under and around your play equipment. The protective surfacing should be applied to a depth that is suitable for the equipment height in accordance with ASTM F1292. There are different types of surfacing to choose from; whichever product you select, follow these guidelines:

## Loose-Fill Materials

- Maintain a minimum depth of 9 inches of loose-fill materials such as wood mulch/chips, engineered wood fiber (EWF), or shredded/recycled rubber mulch for equipment up to 8 feet high; and 9 inches of sand or pea gravel for equipment up to 5 feet high. NOTE: An initial fill level of 12 inches will compress to about a 9-inch depth of surfacing over time. The surfacing will also compact, displace, and settle, and should be periodically raked and refilled to maintain at least a 9-inch depth.
- Use a minimum of 6 inches of protective surfacing for play equipment less than 4 feet in height. If maintained properly, this should be adequate. (At depths less than 6 inches, the protective material is too easily displaced or compacted.)

NOTE: Do not install home playground equipment over concrete, asphalt, or any other hard surface. A fall onto a hard surface can result in serious injury to the equipment user. Grass and dirt are not considered protective surfacing because wear and environmental factors can reduce their shock absorbing effectiveness. Carpeting and thin mats are not adequate protective surfacing. Ground level equipment -- such as a sandbox, activity wall, playhouse or other equipment that has no elevated play surface -- does not need any protective surfacing.

- Use containment, such as digging out around the perimeter and/or lining the perimeter with landscape edging. Don't forget to account for water drainage.
- Periodically rake, check and maintain the depth of the loose-fill surfacing material. Marking the correct depth on the play equipment support posts will help you to see when the material has settled and needs to be raked and or replenished. Be sure to rake and evenly redistribute the surfacing in heavily used areas.
- Do not install loose fill surfacing over hard surfaces such as concrete or asphalt.

## Poured-In-Place Surfaces or Pre-Manufactured Rubber Tiles

You may be interested in using surfacing other than loose-fill materials - like rubber tiles or poured-in-place surfaces.

- Installations of these surfaces generally require a professional and are not "do-it yourself" projects.
- Review surface specifications before purchasing this type of surfacing. Ask the installer/manufacturer for a report showing that the product has been tested to the following safety standard: ASTM F1292 *Standard Specification for Impact Attenuation of Surfacing Materials within the Use Zone of Playground Equipment*. This report should show the specific height for which the surface is intended to protect against serious head injury. This height should be equal to or greater than the fall height - vertical distance between a designated play surface (*elevated surface for standing, sitting, or climbing*) and the protective surfacing below - of your play equipment.
- Check the protective surfacing frequently for wear.

## Placement

Proper placement and maintenance of protective surfacing is essential. Refer to diagram on front cover. Be sure to;

- Extend surfacing at least 2m from the equipment in all directions.
- For to-fro swings, extend protective surfacing in front of and behind the swing to a distance equal to twice the height of the top bar from which the swing is suspended.
- For tire swings, extend surfacing in a circle whose radius is equal to the height of the suspending chain or rope, plus 6 feet in all directions.

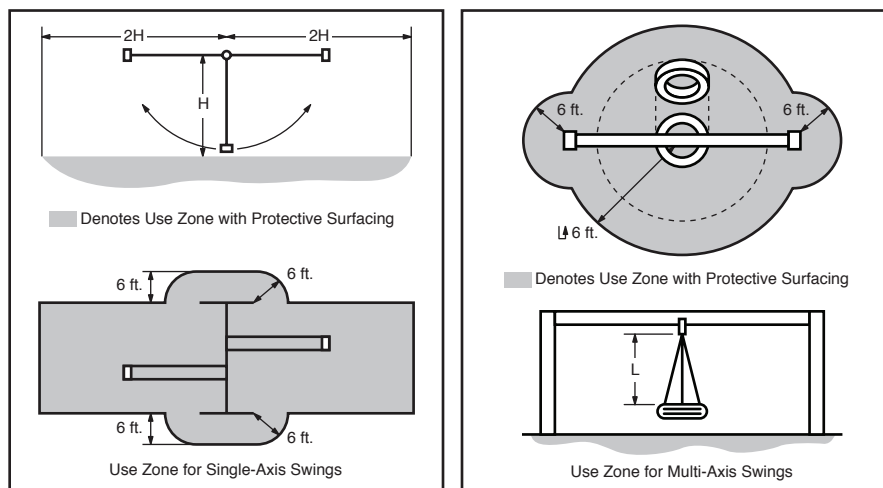

# Instructions for Proper Maintenance

Your KidKraft Play System is designed and constructed of quality materials with your child's safety in mind. As with all outdoor products used by children, it will weather and wear. To maximize the enjoyment, safety and life of your Play Set, it is important that you, the owner, properly maintain it.

## Check the following at the beginning of the play season:

<p><b>HARDWARE:</b></p> <ul style="list-style-type: none"> <li>✓ Check metal parts for rust. If found, sand and repaint using a non-lead paint complying with 16 CFR 1303.</li> <li>✓ Inspect and tighten all hardware. On wood assemblies <b>DO NOT OVER-TIGHTEN</b> as to cause crushing and splintering of wood.</li> <li>✓ Check for sharp edges or protruding screw threads, add washers if required.</li> </ul>		<p><b>GROUND STAKES (ANCHORS):</b></p> <ul style="list-style-type: none"> <li>✓ Check for looseness, damage or deterioration. Should firmly anchor unit to ground during use. Re-secure and or replace, if necessary.</li> </ul> <p><b>SWING HANGERS:</b></p> <ul style="list-style-type: none"> <li>✓ Check that bolts are secure and tight. Quick clips should be completely closed and threaded clips screwed tight.</li> <li>✓ If squeaking occurs lubricate bushings with oil or WD-40®.</li> </ul> <p><b>SWINGS, ROPES AND RIDES:</b></p> <ul style="list-style-type: none"> <li>✓ Reinstall if removed during cold season. Check all moving parts including swing seats, ropes, chains and attachments for wear, rust and other deterioration. Replace as needed.</li> <li>✓ Check that ropes are tight, secure at both ends and cannot loop back as to create an entrapment.</li> </ul>
<p>If Bolt protrudes beyond T-Nut</p> <p>Use an extra Flat Washer</p>	<p><b>WOOD PARTS:</b></p> <ul style="list-style-type: none"> <li>✓ Check all wood members for deterioration, structural damage and splintering. Sand down splinters and replace deteriorated wood members. As with all wood, some checking and small cracks in grain is normal.</li> <li>✓ Unprotected, they will appear weathered over time. Periodic application of an exterior water repellent or stain (water-based) will help improve appearance and life.</li> </ul>	
<p><b>SHOCK ABSORBING SURFACING:</b></p> <ul style="list-style-type: none"> <li>✓ Check for foreign objects. Rake and check depth of loose fill protective surfacing materials to prevent compaction and maintain appropriate depth. Replace as necessary. (See Protective Surfacing, page 3)</li> </ul>		

## Check twice a month during play season:

<p><b>HARDWARE:</b></p> <ul style="list-style-type: none"> <li>✓ Inspect for tightness. Must be firmly against, but not crushing the wood. <b>DO NOT OVER-TIGHTEN.</b> This will cause splintering of wood.</li> <li>✓ Check for sharp edges or protruding screw threads. Add washers if required.</li> </ul>	<p><b>SHOCK ABSORBING SURFACING:</b></p> <ul style="list-style-type: none"> <li>✓ Rake and check depth of loose fill protective surfacing materials to prevent compaction and maintain appropriate depth. Replace as necessary. (See Protective Surfacing, page 3)</li> </ul>
---	---

## Check once a month during play season:

<p><b>SWING HANGERS:</b></p> <ul style="list-style-type: none"> <li>✓ Check that they are secure and orientated correctly. Hook should rotate freely and perpendicular to support beam.</li> <li>✓ If squeaking occurs lubricate bushings with oil or WD-40®.</li> </ul>	<p><b>SWINGS AND RIDES:</b></p> <ul style="list-style-type: none"> <li>✓ Check swing seats, all ropes, chains and attachments for fraying, wear, excessive corrosion or damage. Replace if structurally damaged or deteriorated.</li> </ul>
--	---

## Check at the end of the play season:

<p><b>SWINGS AND RIDES:</b></p> <ul style="list-style-type: none"> <li>✓ To prolong their life, remove swings and store inside when outside temperature is below 32°F/0°C. Below freezing, plastic parts may become more brittle.</li> </ul>	<p><b>SHOCK ABSORBING SURFACING:</b></p> <ul style="list-style-type: none"> <li>✓ Rake and check depth of loose fill protective surfacing materials to prevent compaction and maintain appropriate depth. Replace as necessary. (See Protective Surfacing, page 3)</li> </ul>
--	---

**If you dispose of your play set:** Please disassemble and dispose of your unit so that it does not create any unreasonable hazards at the time it is discarded. Be sure to follow your local waste ordinances.

## About Our Wood

KidKraft Premium Play Systems uses 100% FSC wood. Although we take great care in selecting the best quality lumber available, wood is still a product of nature and susceptible to weathering which can change the appearance of your set.

### What causes weathering? Does it affect the strength of my Play System?

One of the main reasons for weathering is the effects of water (moisture); the moisture content of the wood at the surface is different than the interior of the wood. As the climate changes, moisture moves in or out of the wood, causing tension which can result in checking and or warping. You can expect the following due to weathering. These changes will not affect the strength of the product:

1. **Checking** is surface cracks in the wood along the grain. A post (4" x 4") will experience more checking than a board (1" x 4") because the surface and interior moisture content will vary more widely than in thinner wood.
2. **Warping** results from any distortion (twisting, cupping) from the original plane of the board and often happens from rapid wetting and drying of the wood.
3. **Fading** happens as a natural change in the wood color as it is exposed to sun-light and will turn a grey over time.

### How can I reduce the amount of weathering to my Play System?

At the factory we have coated the wood with a water repellent or stain. This coating decreases the amount of water absorption during rain or snow thus decreasing the tension in the wood. Sunlight will break down the coating, so we recommend applying a water repellent or stain on a yearly basis (see your local stain and paint supplier for a recommended product).

Most weathering is just the normal result of nature and will not affect safe play and enjoyment for your child. However if you are concerned that a part has experienced a severe weathering problem please call our consumer relations department for further assistance.

### Complete and mail registration card to receive important product notifications and assure prompt warranty service.

## 5 Year Limited Warranty

KidKraft warrants that this product is free from defect in materials and workmanship for a period of one year from the original date of purchase. In addition, lumber is warranted for 5 years against structural failure due to rot and insect damage. All other parts, such as hardware, swings, rides, accessories, and slides carry a one-year warranty only.

This warranty applies to the original owner and registrant and is non-transferable.

Regular maintenance is required to assure the integrity of your Play System. This warranty does not cover any inspection cost.

This Limited Warranty does not cover:

- Labor for replacement of any defective item(s);
- Incidental or consequential damages;
- Cosmetic defects which do not affect performance or integrity;
- Vandalism; improper use or installation; acts of nature;
- Minor twisting, warping, checking, or any other natural occurring properties of wood that do not affect performance or integrity.

KidKraft products have been designed for safety and quality. Any modifications made to the original product could damage the structural integrity of the unit leading to failure and possible injury.

Kidkraft cannot assume any responsibility for modified products. Furthermore, modification voids any and all warranties.

This product is warranted for **RESIDENTIAL USE ONLY**. Under no circumstance should a KidKraft Play System be used in public settings such as schools, churches, playgrounds, parks, day cares and the like. Such use may lead to product failure and potential injury. Any and all public use will void this warranty.

KidKraft disclaims all other representations and warranties of any kind, express or implied.

This Warranty gives you specific legal rights. You may have other rights as well which vary from state to state or province to province. This warranty excludes all consequential damages, however, some states do not allow the limitation or exclusion of consequential damages, and therefore this limitation may not apply to you.



# Keys to Assembly Success

## Tools Required

<ul style="list-style-type: none"> <li>• Tape Measure</li> <li>• Carpenters Level</li> <li>• Carpenters Square</li> <li>• Claw Hammer</li> <li>• Standard or Cordless Drill</li> </ul>	<ul style="list-style-type: none"> <li>• #1, #2 &amp; #3 Phillips or Robertson Bits or Screwdriver</li> <li>• Ratchet with extension (1/2" &amp; 9/16" sockets)</li> </ul>	<ul style="list-style-type: none"> <li>• Open End Wrench (7/16", 1/2" &amp; 9/16")</li> <li>• Adjustable Wrench</li> <li>• 1/8" &amp; 3/16" Drill Bits</li> <li>• Pencil</li> </ul>	<ul style="list-style-type: none"> <li>• 3/16" Hex Key</li> <li>• 8' Step Ladder</li> <li>• Safety Glasses</li> <li>• Adult Helpers</li> </ul>
--	--	---	--

## Part Identification Key



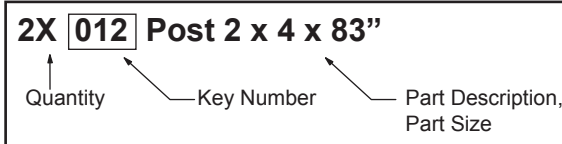



On each page, you will find the parts and quantities required to complete the assembly step illustrated on that page. Here is a sample.



**Key Number:** The first two digits represent the step number. The third digit represents the piece. Note that if the part is used in multiple steps then the number only reflects the first step it is used in.

## Symbols

Throughout these instructions symbols are provided as important reminders for proper and safe assembly.

<p>This identifies information that requires special attention. Improper assembly could lead to an unsafe or dangerous condition.</p> 	<p>Check that set or assembly is properly level before proceeding.</p> <p>Use Level</p> 
<p>Use Help</p>  <p>Use Help</p>  <p>Where this is shown, 2 or 3 people are required to safely complete the step. To avoid injury or damage to the assembly make sure to get help!</p>	<p>Pre-drill 1/8" &amp; 3/16" Bit</p> <p>Pre-drill a pilot hole before fastening screw or lag to prevent splitting of wood.</p>
<p>Measure Distance</p>  <p>Check that assembly is square before tightening bolts.</p> <p>Use a measuring tape to assure proper location.</p>	<p>Square Assembly</p>  <p>Tighten Bolts</p>  <p>This indicates time to tighten bolts, but not too tight! Do not crush the wood. This may create splinters and cause structural damage.</p>

## CAUTION – Protrusion Hazard

Once the assembly is tightened, watch for exposed threads. If a thread protrudes from the T-Nut, remove the bolt and add washers to eliminate this condition. Extra washers have been provided for this purpose.

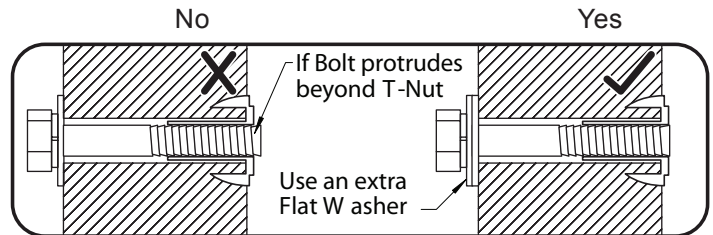

## Proper Hardware Assembly

Lag screws require drilling pilot holes to avoid splitting wood. Only a flat washer is required. For ease of installation liquid soap can be used on all lag-type screws.

For bolts, tap T-Nut into hole with hammer. Insert the hex bolt through lock washer first then flat washer then hole. Because the assemblies need to be squared do not completely tighten until instructed. Pay close attention to diameter of the bolts. 5/16" is slightly larger than 1/4".

**Note:** Wafer head bolts with blue lock tight or a bolt with a Ny-Lok nut do NOT require a lock washer.

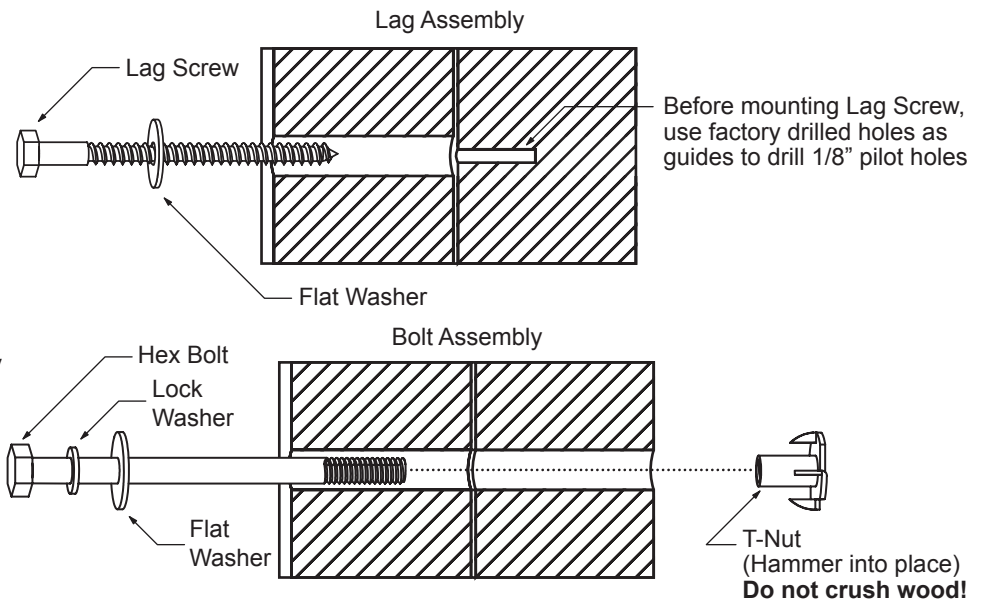

# Your Key To Quick Assembly

**SORTING WOOD PARTS INTO EACH ASSEMBLY STEP WILL SAVE TIME!**

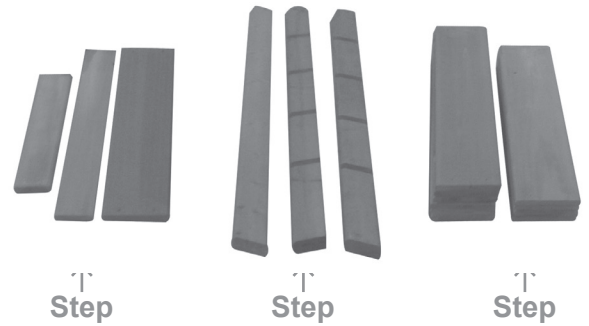

## SAVE TIME - TIP #1:

Open each box with wood parts and look for the Key Number stamped on the end of the wood part (see chart below). Sort each wood part into the different assembly steps.

**2X**      **012**      **Post**      **2 x 4 x 83"**  
↑            ↑            ↑            ↑  
Part Quantity    Key Number    Part Description    Part Size

<b>Step Number</b> (This is Step 1)	<b>01</b>	<b>2</b>	<b>Order Listed</b> (The order the part is listed in step 1)
--	-----------	----------	---

**Key Number:** The first two digits represent the step number. The third digit represents the order in which the part is listed in the step.

*Note that if the part is used in multiple steps then the key number only reflects the first step it is used in.*

## SAVE TIME - TIP #2:

In addition to the key number stamp, you can also identify the wood parts by using the Parts Identification pages in the manual.

## HARDWARE:

The majority of each hardware part comes packed in a separate bag so you do not need to sort the hardware. Each assembly step indicates which hardware (bolt, screw, washer etc.) you will require to complete the step.

# FRONT

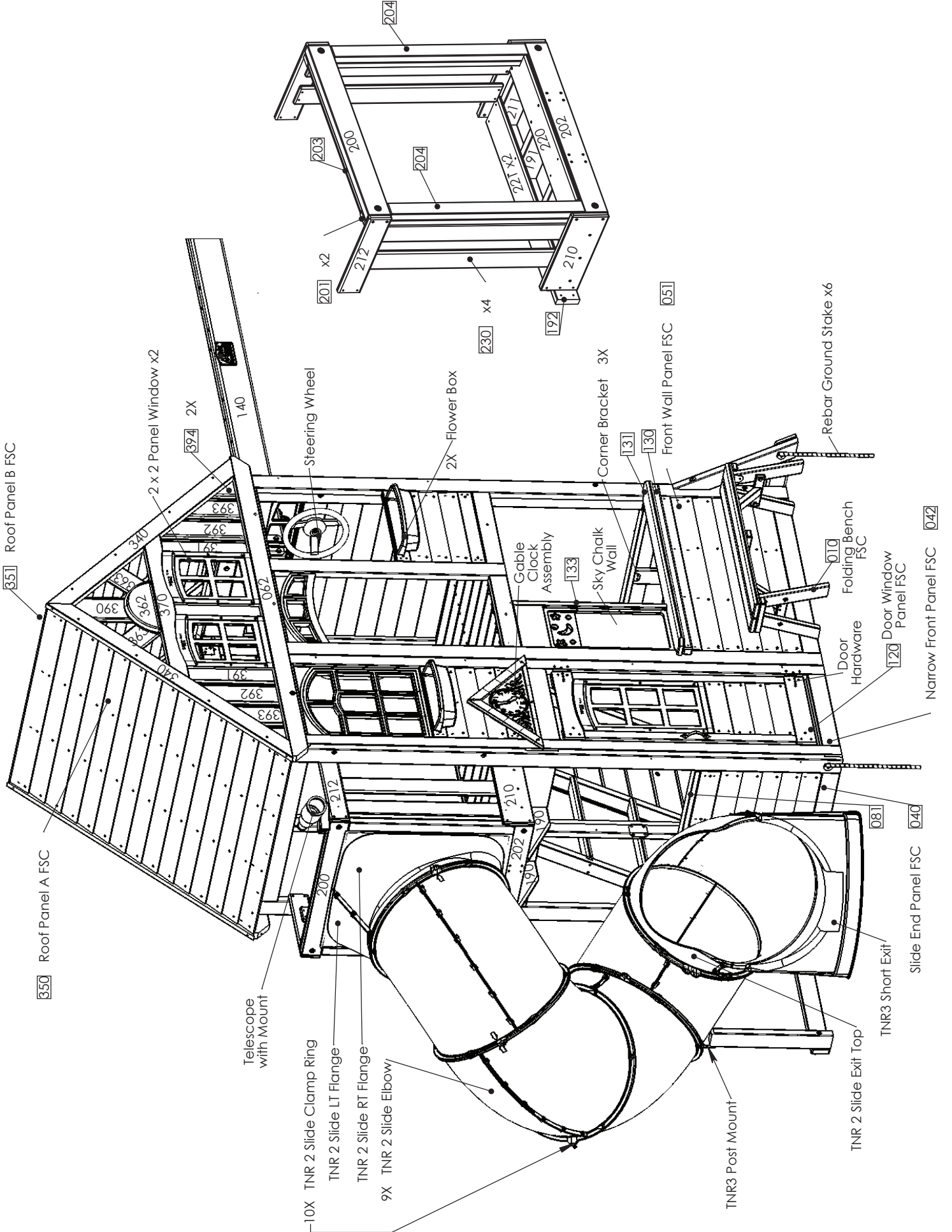



# BACK

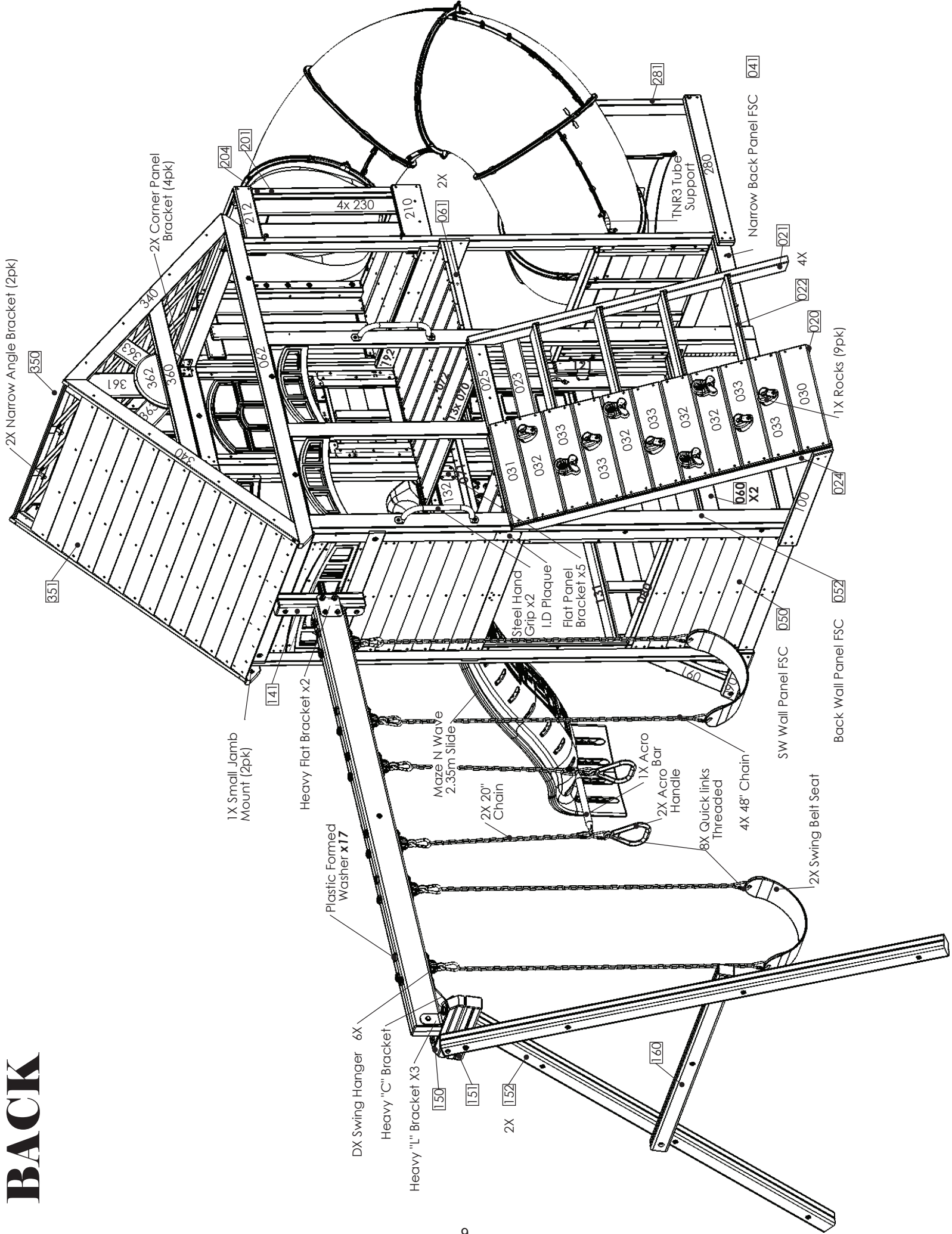

# Part Identification (Reduced Size)

(1) **023** - 1 x 4 x 21" - Ladder Gap FSC - Box 2 - 4598958

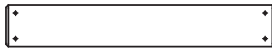

(4) **230** - 1 x 4 x 29" - Cedar Wall FSC - Box 3 - 4591975

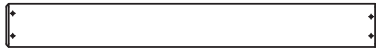

(1) **072** - 1 x 4 x 35-5/8" - Floor Board FSC - Box 3 - 4599050



(1) **025** - 1 x 4 x 41-3/4" - RW - AL Support FSC - Box 2 - 4599062

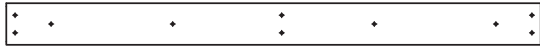

(2) **394** - 1 x 5 x 7-1/8" - End Gable C FSC - Box 3- 4599047



(4) **363** - 1 x 5 x 10" - Sunburst Side FSC - Box 2 - 4599066



(2) **393** - 1 x 5 x 12-1/8" - End Gable B FSC - Box 3 - 4599046

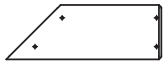

(2) **392** - 1 x 5 x 17-1/8" - End Gable D FSC - Box 3 - 4599048



(2) **391** - 1 x 5 x 17-1/8" - End Gable A FSC - Box 3 - 4599045



(1) **031** - 1 x 5 x 22-1/8" - Access Board FSC - Box 2 - 4599032



(13) **070** - 1 x 5 x 35-5/8" - Floor Board FSC - Box 2,3 - 4599051



(1) **361** - 1 x 6 x 19" - Bk Centre Gable FSC - Box 2 - 4599033



(1) **220** - 1 x 6 x 29-3/8" - Crowsnest Gap Board FSC - Box 2 - 4599040



(2) **221** - 1 x 6 x 29-3/8" - Crowsnest Floor FSC - Box 2 - 4599038



(5) **033** - 1 x 6 x 22-1/8" - Board Rock B FSC - Box 2 - 4598512



(4) **032** - 1 x 6 x 22-1/8" - Board Rock A FSC - Box 2 - 4598511

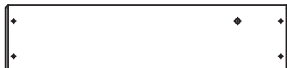

(1) **030** - 1 x 6 x 22-1/8" - Access Rock Bottom FSC - Box 3 - 4598515

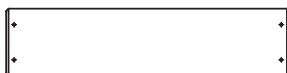

# Part Identification (Reduced Size)

(1) - **390** - 1 x 6 x 34-15/16" - Fr Centre Gable FSC - Box 3 - 4599052

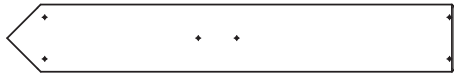

(1) **133** - 1 x 2 x 27-7/16" - Chalkwall Side FSC - Box 2 - 4599035

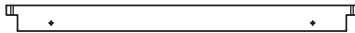

(2) **201** - 1 x 2 x 34-1/8" - Upright Crowsnest FSC - Box 3 - 4599072



(2) **212** - 3/4 x 3-1/4 x 14-3/4" - Crowsnest Side FSC - Box 2 - 4599042



(2) **210** - 3/4 x 5-1/4 x 14-3/4" - Crowsnest Bottom Side FSC - Box 3 - 4599037



(1) **121** - 5/4 x 3 x 10" - Door Stop FSC - Box 2 - 4592715



(1) **081** - 5/4 x 3 x 33" - Half Wall Top FSC - Box 3 - 4599053

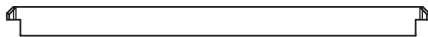

(1) **080** - 5/4 x 3 x 33-1/2" - SW Wall Top FSC - Box 3 - 4599071

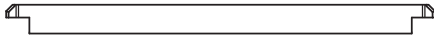

(1) **090** - 5/4 x 4 x 14 1/4" - SW Ground FSC - Box 3 - 4592606



(4) **022** - 5/4 x 4 x 19-1/2" - Tread FSC - Box 3 - 4598957



(1) **203** - 5/4 x 4 x 25-1/2" - Crowsnest Short FSC - Box 3 - 4598115



(1) **100** - 5/4 x 4 x 27-3/4" - RW-AL Ground Brace FSC - Box 3 - 4599061



(1) **131** - 5/4 x 5 x 39-5/8" - Table Top FSC - Box 3 - 4592611



(2) **362** - 5/4 x 6 x 12" - Starburst Centre FSC - Box 3 - 4598305



(2) **204** - 1-1/4 x 2 x 27-1/2" - Crowsnest Spacer FSC - Box 2 - 4599043



(1) **281** - 1-1/4 x 3 x 20-1/4" - TNR Upright FSC - Box 3 - 4598965



(1) **091** - 1-1/4 x 3 x 22" - Diagonal FSC - Box 2 - 4592607

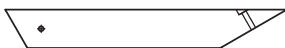

(1) **192** - 5/4 x 4 x 34" - Crowsnest Back FSC - Box 2 - 4599036





# Part Identification (Reduced Size)

- (1) **280** - 1-1/4 x 3 x 32-1/4" - TNR Ground Brace FSC - Box 2 - 4598963

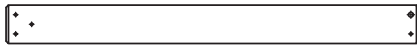

- (1) **360** - 1-1/4 x 3 x 34-1/2" - Back Gable Support FSC - Box 3 - 4599031



- (1) **370** - 1-1/4 x 3 x 34-1/2" - Mid Gable Support FSC - Box 3 - 4599057



- (2) **060** - 1-1/4 x 3 x 40-3/4" - Floor Joist FSC - Box 3 - 4592608



- (4) **340** - 1-1/4 x 3 x 50-15/16" - Roof Rafter FSC - Box 3 - 4599059

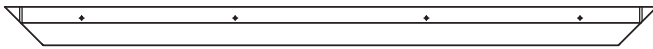

- (1) **071** - 1-1/4 x 3 x 63-1/4" - Long Floor Joist FSC - Box 3 - 4599056



- (2) **062** - 1-1/4 x 3 x 72" - Roof Support FSC - Box 3 - 4599060



- (1) **132** - 1-1/4 x 5 x 10" - Chalkwall Block FSC - Box 3 - 4599034

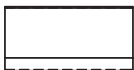

- (1) **024** - 1-3/8 x 2-1/2 x 57-53/64" - Rock Rail FSC - Box 1 - 4599058

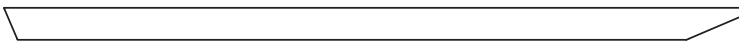

- (1) **020** - 1-3/8 x 2-1/2 x 57-53/64" - Left Access FSC - Box 1 - 4599054

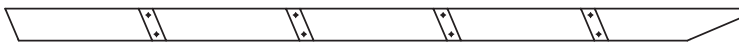

- (1) **021** - 1-3/8 x 2-1/2 x 57-53/64" - Right Access FSC - Box 1 - 4599055

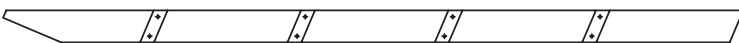

- (1) **130** - 2 x 2 x 39-5/8" - Table Support FSC - Box 1 - 4592612



- (2) **061** - 2 x 2 x 63" Side Joist FSC - Box 1 - 4599064



- (2) **211** - 2 x 4 x 12-1/2" - Short Crowsnest Joist FSC - Box 2 - 4599063



- (2) **191** - 2 x 4 x 13-1/2" - Crowsnest Joist FSC - Box 3 - 4599041

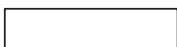

- (1) **202** - 2 x 4 x 29-1/2" - Crowsnest Front FSC - Box 3 - 4599039

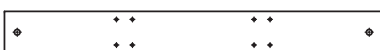

- (1) **200** - 2 x 4 x 29-1/2" - Crowsnest Top FSC - Box 3 - 4599044

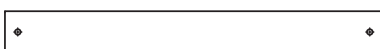

- (2) **190** - 2 x 6 x 15" Crowsnest Gusset FSC - Box 2 - 4598112



# Part Identification (Reduced Size)

(1) **151** - 2-1/2 x 3 x 15" - Block SW FSC - Box 3 - 4598507

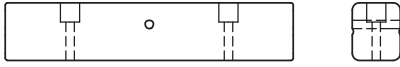

(1) **150** - 2-1/2 x 3 x 15" - SW Block Angle FSC - Box 3 - 4599068

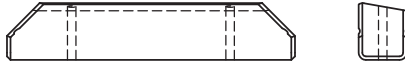

(1) **141** - 4 x 4 x 16" - SW Mount FSC - Box 3 - 4599069

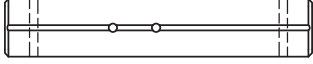

(1) **160** - 2-1/2 x 3 x 51" - Support Cross FSC - Box 1 - 4599067



(2) **152** - 4 x 4 x 92" - SW Post FSC - Box 1 - 4599070

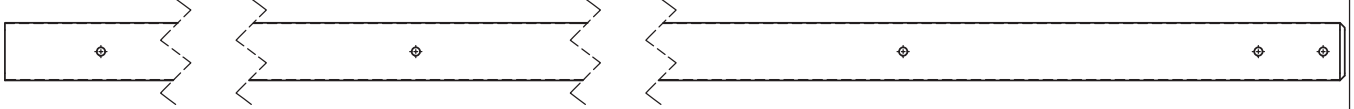

(1) **140** - 4 x 6 x 92" - Engineered SW Beam FSC - Box 1 - 4599049

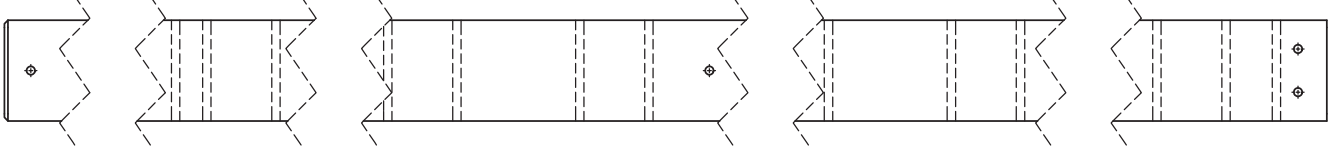

1x - TNR 2 Slide Rt Flange  
(3310223) Yellow

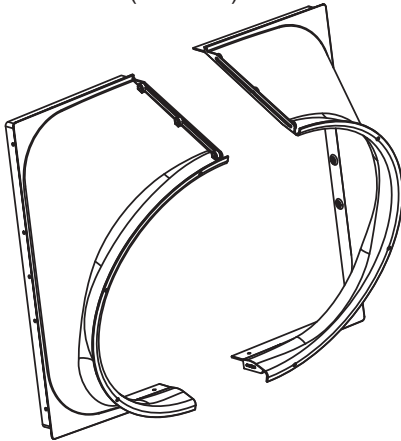

1x - TNR 2 Slide Lt Flange  
(3310222) Yellow

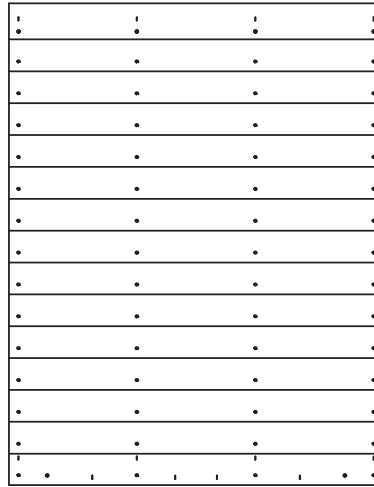

(1) **350** - 1-1/4 x 39 x 50-3/16"  
Roof Panel A FSC - Box 3 - 47599022

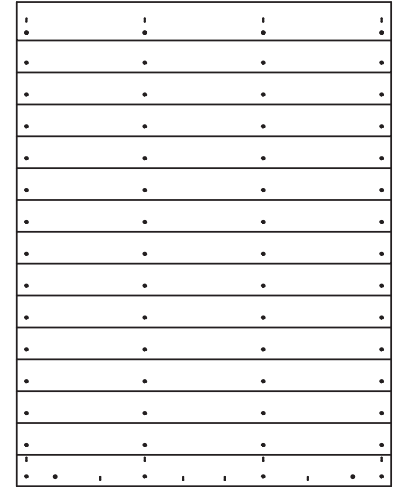

(1) **351** - 1-1/4 x 39 x 50-7/16"  
Roof Panel B FSC - Box 3 - 47599029

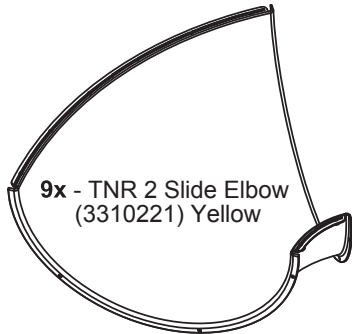

9x - TNR 2 Slide Elbow  
(3310221) Yellow

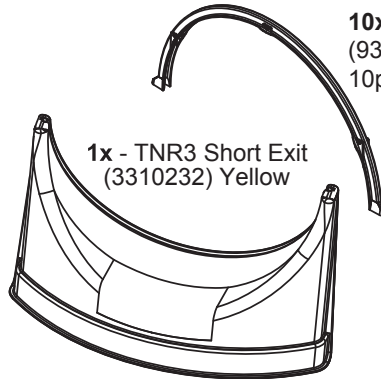

1x - TNR3 Short Exit  
(3310232) Yellow

10x - TNR 2 Clamp Ring  
(9300220) (Yellow)  
10pcs number 3300220

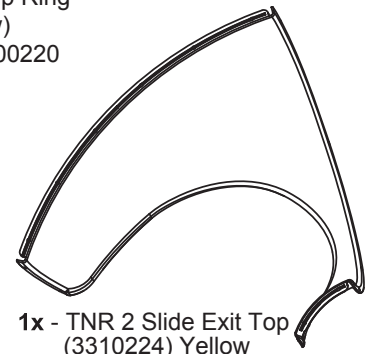

1x - TNR 2 Slide Exit Top  
(3310224) Yellow

# Part Identification (Reduced Size)

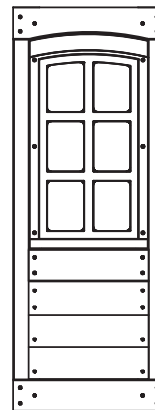
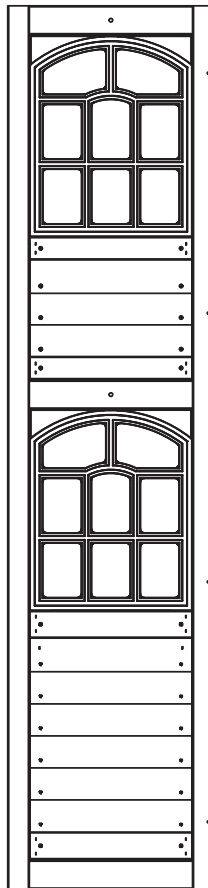
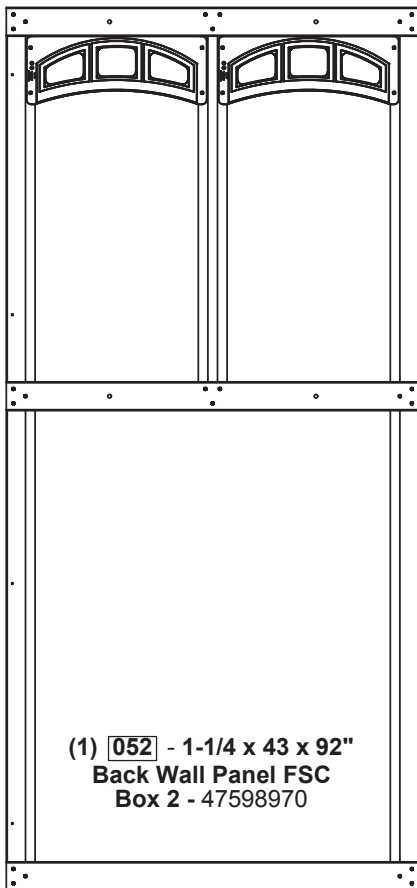
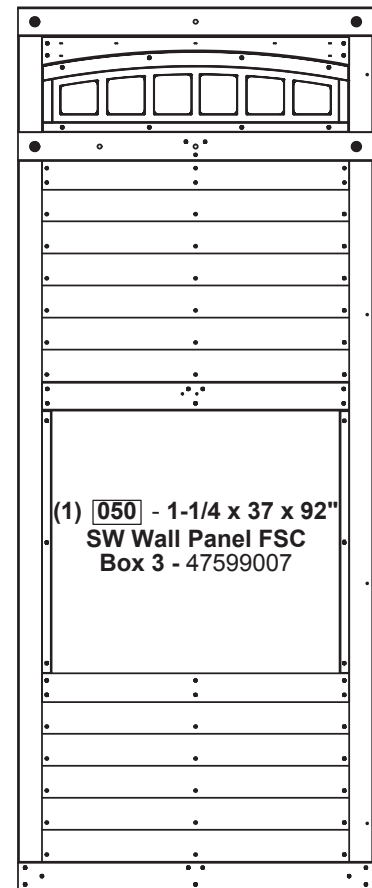
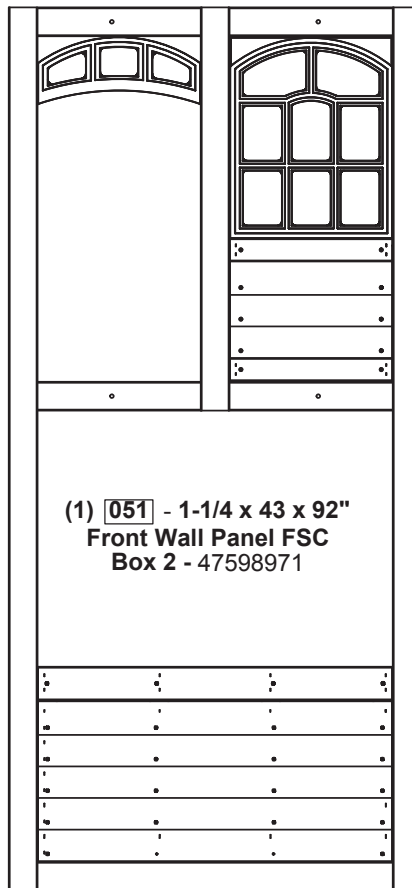
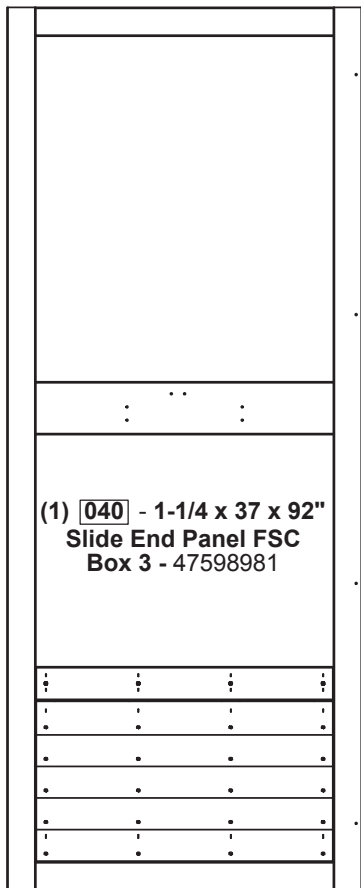

(1) **120** - 1-1/4 x 15-3/4 x 42-1/8"  
Door Window Panel FSC  
Box 2 47598977



(1) **010** - 2-13/32 x 6-3/4 x 34"  
47592658 Folding Bench FSC - Box 2

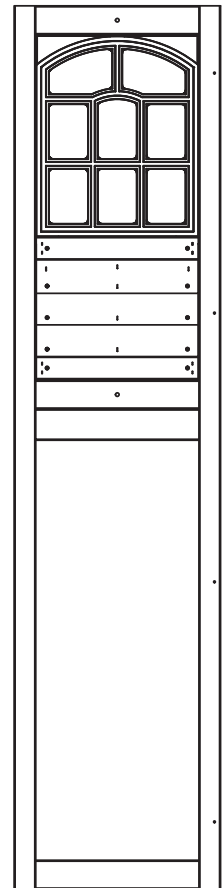

(1) **042** - 1-1/4 x 21-1/2 x 92" - 47599003  
Narrow Front Panel FSC - Box 2



# Hardware Identification (Actual Size)

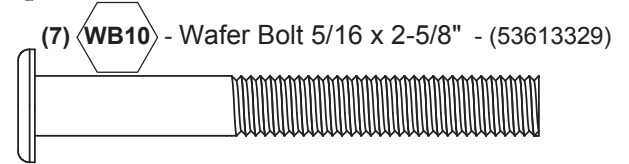
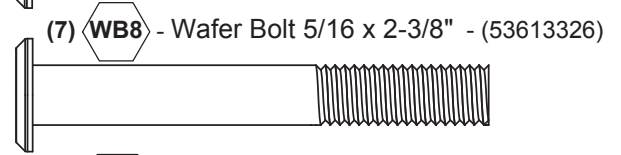
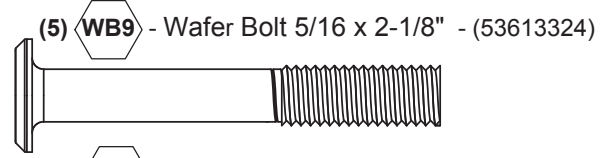
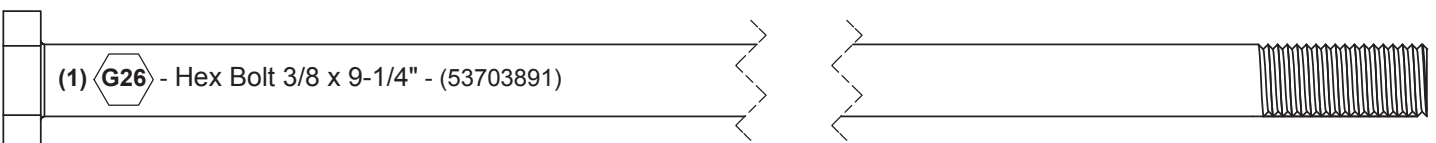
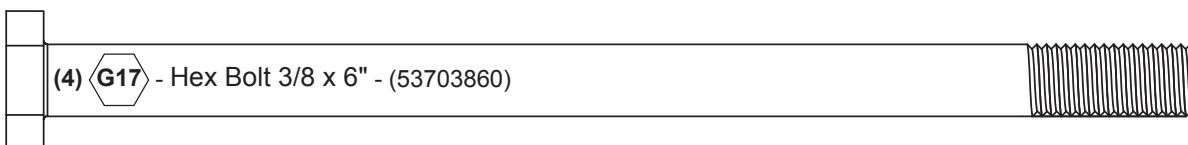
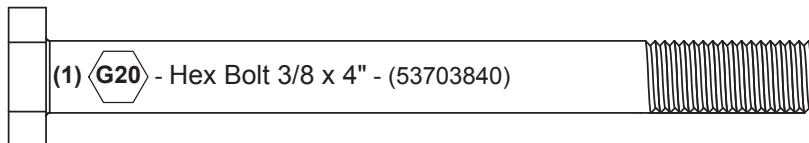
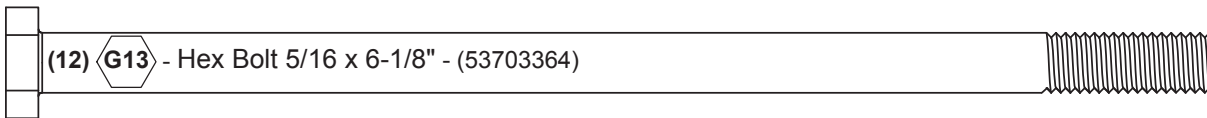
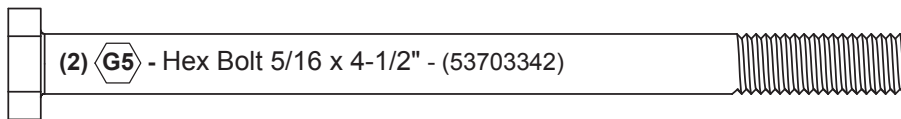
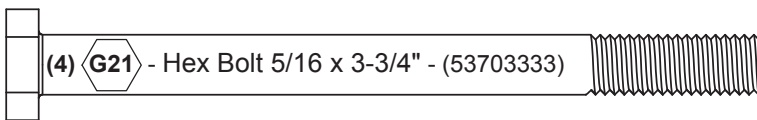
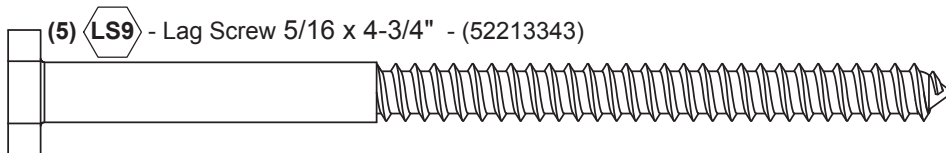
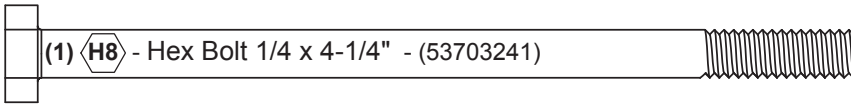
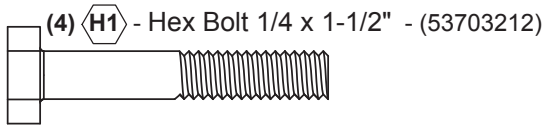
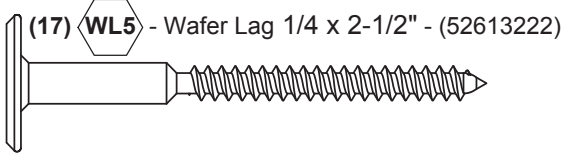
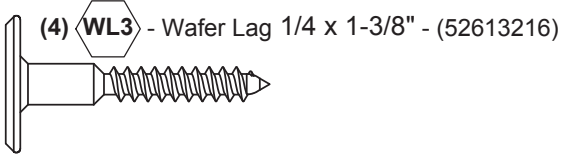
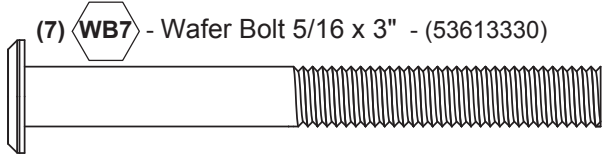

# Hardware Identification (Actual Size)

(1) **LW2** - 5/16" Lock Washer - (51303300)



(14) **LW1** - 1/4" Lock Washer - (51303200)



(89) **LN1** - 1/4 Lock Nut - (54303200)



(18) **LN2** - 5/16" Lock Nut - (54303300)

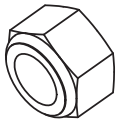

(6) **LN3** - 3/8 Lock Nut - (54303800)

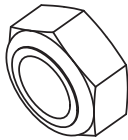

(89) **PB1** - Pan Bolt 1/4 x 3/4" - (53453203)

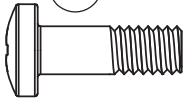

(1) **PB6** - Pan Bolt 1/4 x 1" - (53413210)

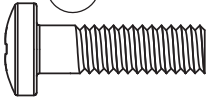

(33) **S13** - Pan Screw #6 x 5/8" - (52413908)



(21) **S10** - Pan Screw #8 x 1" - (52433510)

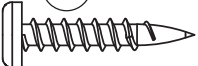

(52) **S8** - Pan Screw #12 x 3/4" - (52433603)

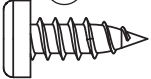

(17) **S6** - Pan Screw #12 x 1" - (52433610)

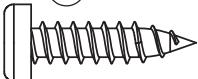

(28) **S7** - Pan Screw #12 x 2" - (52433620)

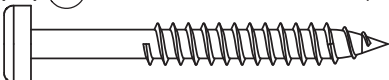

(9) **FW0** - 3/16" Flat Washer - (51103100)

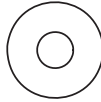

(11) **FW1** - 1/4" Flat Washer - (51103200)

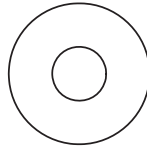

(70) **FW2** - 5/16" Flat Washer - (51103300)

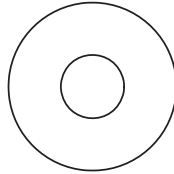

(12) **FW10** - 3/8" Flat Washer - (51103800)

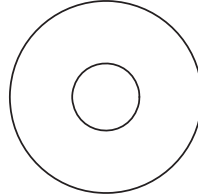

(5) **TN1** - 1/4" T - Nut - (54503200)

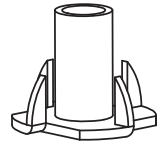

(26) **TN2** - 5/16" T- Nut - (54503300)

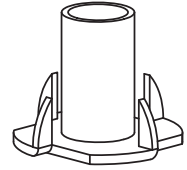

(9) **BN1** - 1/4" Barrel Nut - (54803200)

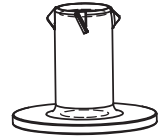

(8) **FW6** - #12 Screw Bezel - (9299500)

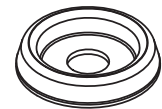

(10) **PB2** - Pan Bolt 1/4 x 1-1/4" - (53433212)

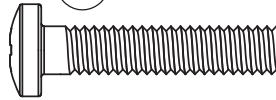

(12) **S0** - Truss Screw #8 x 7/8" - (52933505)

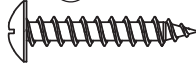

(4) **S18** - Wood Screw #6 x 1" - (52013910)

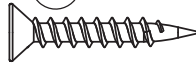

(28) **S33** - Wood Screw #8 x 1" - (52043510)



(215) **S20** - Wood Screw #8 x 1-3/8" - (52043516)



(76) **S11** - Wood Screw #8 x 2" - (52043520)



(47) **S3** - Wood Screw #8 x 2-1/2" - (52043522)



(21) **S4** - Wood Screw #8 x 3" - (52043530)



# Part Identification (Reduced Part Size)



1x - Kidkraft Logo  
Plaque (3320353)

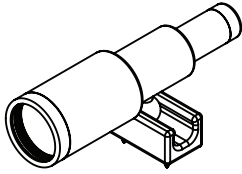

1x - Telescope w/ Mount  
(3320161)



1x - KK Playset Plaque  
(9320374)



1x - TNR3 Post Mount  
(9200257)

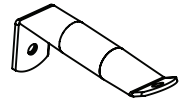

1x - TNR3 Tube Support  
(9200258)



2x - Steel Hand Grip  
(9200211) -Yellow



1x - Plastic Formed  
Washer (18 Pk)  
(3290000)



1x - Rocks (9pk) (3320093)  
Green/Yellow/Burgundy

1x - #2 x 2"  
Robertson Driver  
(9200014)

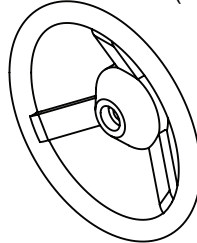
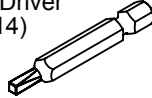

1x - Steering Wheel  
(3320255)

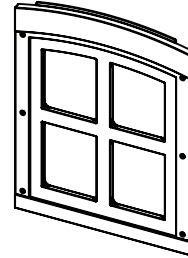

2x - 2 x 2 Panel Window  
(9320118) -Green

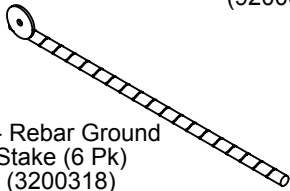

1x - Rebar Ground  
Stake (6 Pk)  
(3200318)

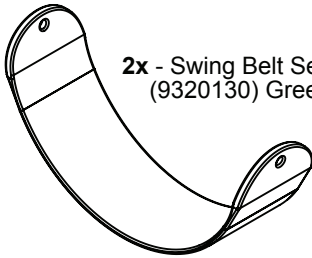

2x - Swing Belt Seat  
(9320130) Green

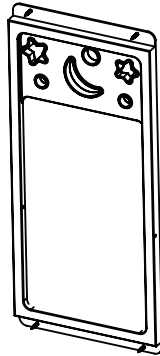

1x - Sky Chalk  
Wall (3320117)

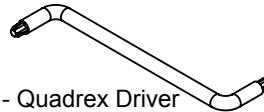

1x - Quadrex Driver  
(9200015)

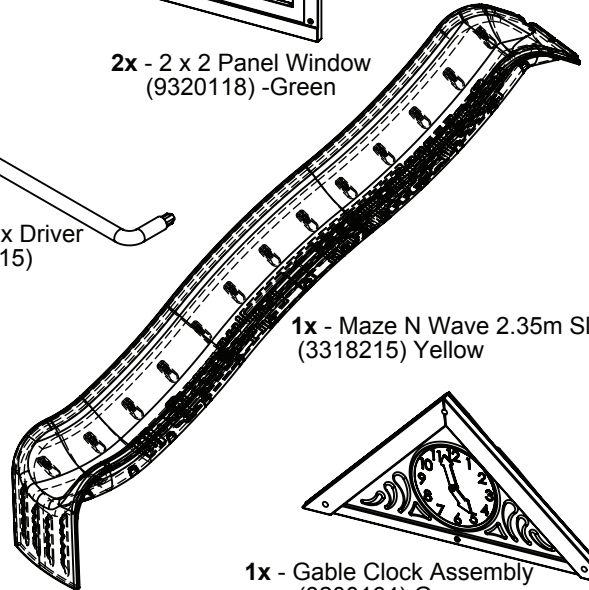

1x - Maze N Wave 2.35m Slide  
(3318215) Yellow

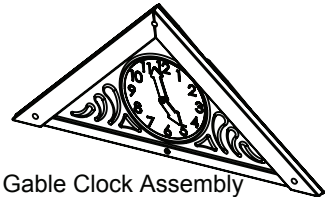

1x - Gable Clock Assembly  
(3200164) Green



2x - Acro Handle  
(9320131) Green

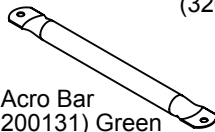

1x - Acro Bar  
(9200131) Green

1x - Quick Links w.  
Thread (2pk)  
(3200022)

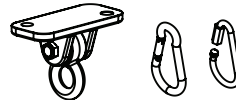

1x - DX Swing Hangers  
with Quick Links (6 Pk)  
(3201950)

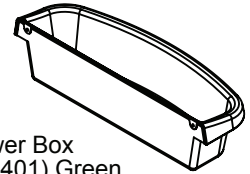

2x - Flower Box  
(9320401) Green

1x - Door Hardware (3201710)

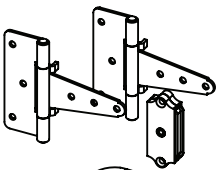

2x 9201712  
Door Hinge -Green

9207713  
Door Catch -Brown

1x Magnetic Catch  
1x Catch Plate



2x 9201711  
Door Handle -Green

1x - Welded Chain Bag (3200173) Green

2x 20" chain -Green

4x 48" chain -Green

1x - Twin Mountain Heavy  
Bracket Set (3205701)  
Green

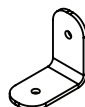

3x - Heavy L-Bracket  
(9200151)



2x - Heavy Flat Bracket  
(9200149)

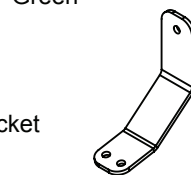

1x - Heavy C-Bracket  
(9200153)

1x - Twin Mountain Bracket Set  
(3205700)



1x - Flat Panel Bracket  
(5 Pk)(3205935)



2x - Narrow Angle  
Bracket (2 Pk)  
(3205939)



2x - Corner Panel  
Bracket (4 Pk)  
(3205975)



1x - Corner  
Bracket (3 Pk)  
(3205970)



1x - Small Jamb Mount  
(2 Pk) (3205947)

# First Step: Inventory Parts - Read This Before Starting Assembly

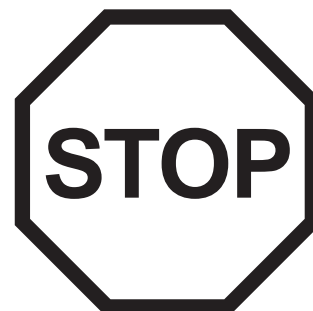
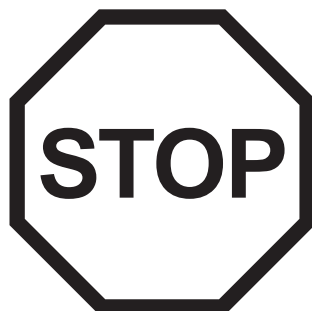
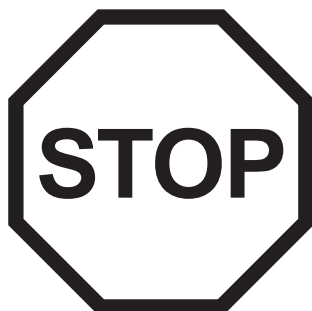
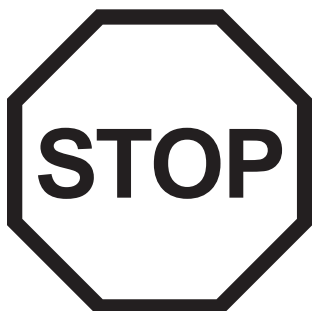

**A.** This is the time for you to inventory all your hardware, wood and accessories, referencing the parts identification sheets. This will assist you with your assembly.

- The wood pieces will have the key number stamped on the ends of the boards. Organize the wood pieces by step, as per the key numbering system below.

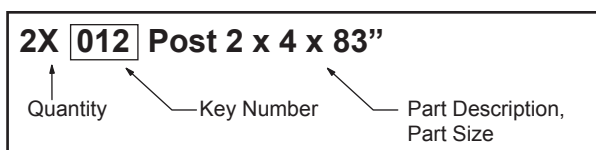

**Key Number:** The first two digits represent the step number. The third digit represents the piece. Note that if the part is used in multiple steps then the number only reflects the first step it is used in.

- Please refer to Page 6 for proper hardware assembly.
- Each step indicates which bolts and/or screws you will need for assembly, as well as any flat washers, lock washers, t-nuts or lock nuts.

**B.** If there are any missing or damaged pieces or you need assistance with assembly please contact the consumer relations department directly. Call us before going back to the store.

1.800.933.0771 or 972.385.0100  
 customerservice@kidkraft.com  
 canadacustomerservice@kidkraft.com  
 For online parts replacement visit  
<https://parts.kidkraft.com/>

+31 20 305 8620  
 europecustomerservice@KidKraft.com  
 For online parts replacement visit  
<https://parts.kidkraft.eu/>

**C.** Read the assembly manual completely, paying special attention to ANSI warnings; notes; and safety/maintenance information on pages 1 - 6.

**D.** Before you discard your cartons fill out the form below.

- The carton I.D. stamp is located on the end of each carton. The tracking number is located on the KidKraft ID Plaque (9320374).
- Please retain this information for future reference. You will need this information if you contact the Consumer Relations Department.

## MODEL NUMBER: F25700X

CARTON I.D. STAMP: \_\_\_ \_\_\_ \_\_\_ \_\_\_ 14459 \_\_\_ (Box 1)

CARTON I.D. STAMP: \_\_\_ \_\_\_ \_\_\_ \_\_\_ 14459 \_\_\_ (Box 4)

CARTON I.D. STAMP: \_\_\_ \_\_\_ \_\_\_ \_\_\_ 14459 \_\_\_ (Box 2)

CARTON I.D. STAMP: \_\_\_ \_\_\_ \_\_\_ \_\_\_ 14459 \_\_\_ (Box 5)

CARTON I.D. STAMP: \_\_\_ \_\_\_ \_\_\_ \_\_\_ 14459 \_\_\_ (Box 3)

CARTON I.D. STAMP: \_\_\_ \_\_\_ \_\_\_ \_\_\_ 14459 \_\_\_ (Box 6)

TRACKING NUMBER (from ID Plaque): \_\_\_\_\_

# Step 1: Bench Assembly

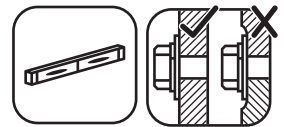

**A:** Open the Folding Bench Assembly. (fig. 1.1, 1.2 and 1.3)

**B:** Make sure assembly is level then secure with 2 (H1) 1/4 x 1-1/2" Hex Bolts (with lock washer, flat washer and t-nut) per side. (fig. 1.4)

**C:** Tighten the top screws in all 4 Bench Legs. (fig. 1.4)

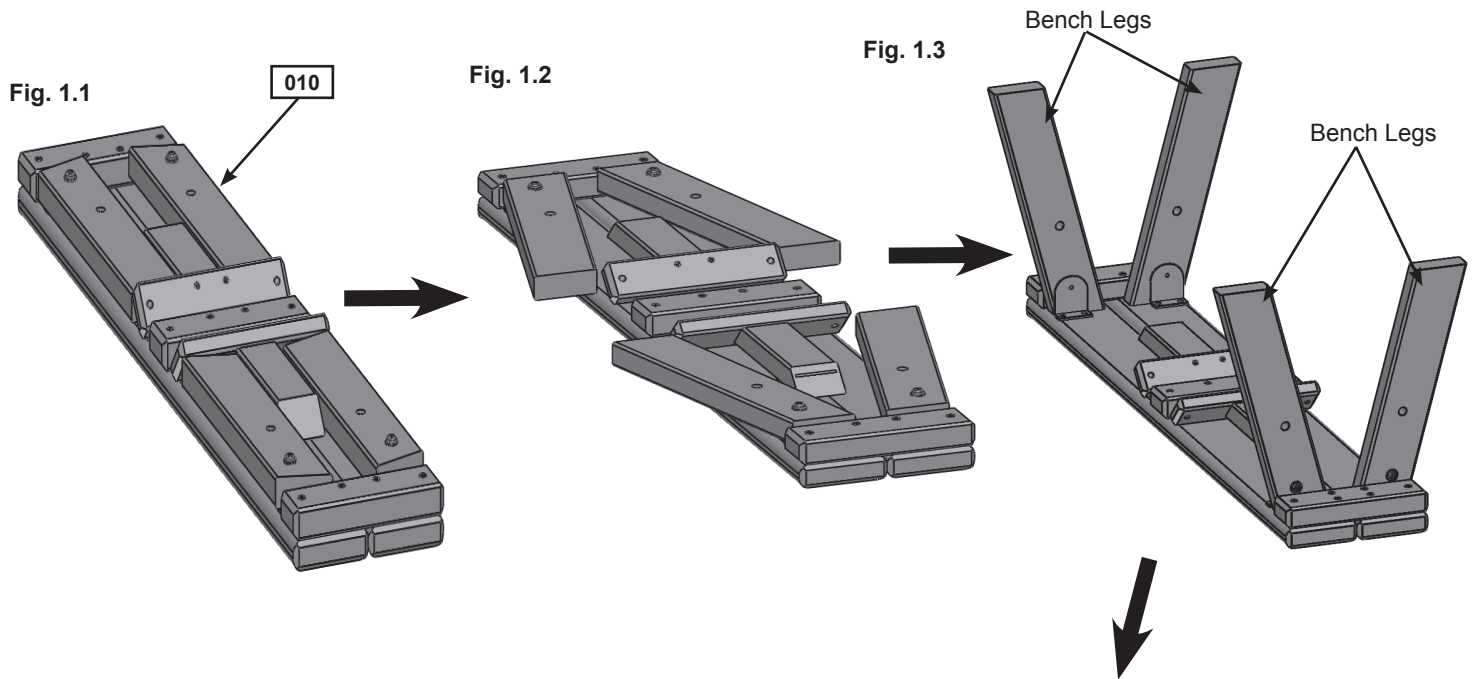
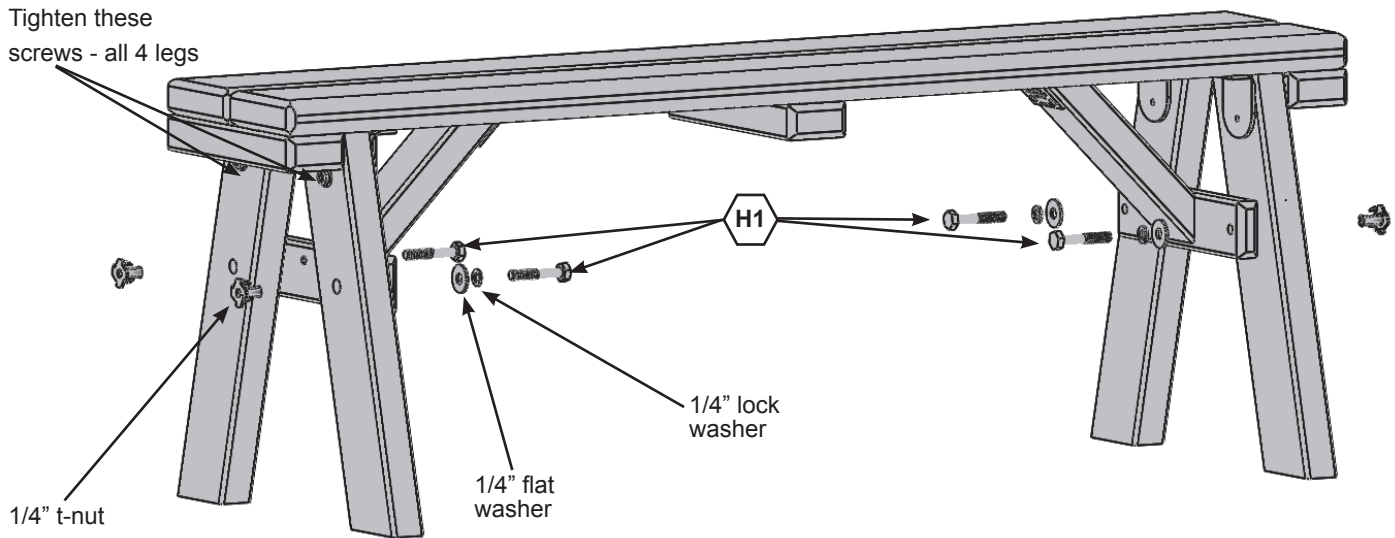

Fig. 1.4

Tighten these screws - all 4 legs



## Wood Parts

1 x 010 Folding Bench 2-13/32 x 6-3/4 x 34"

## Hardware

4 x H1 1/4 x 1-1/2" Hex Bolt  
(1/4" lock washer, 1/4" flat washer, 1/4" t-nut)



# Step 2: Access Ladder / Rockwall Assembly

## Part 1



- A:** Place (020) Left Access on one side of 4 (022) Treads and (021) Right Access on the other side with the grooves facing in. (fig. 2.1)
- B:** Fit each (022) Tread into grooves on both (020) and (021) Access rails, make sure the top edge of the (022) Treads are flush to the front of the Access rails. (fig. 2.1 and 2.2)
- C:** Pre-drill pilot holes with a 1/8" drill bit and attach rails and treads together using 4 (S3) #8 x 2-1/2" Wood Screws per tread. (fig. 2.1)

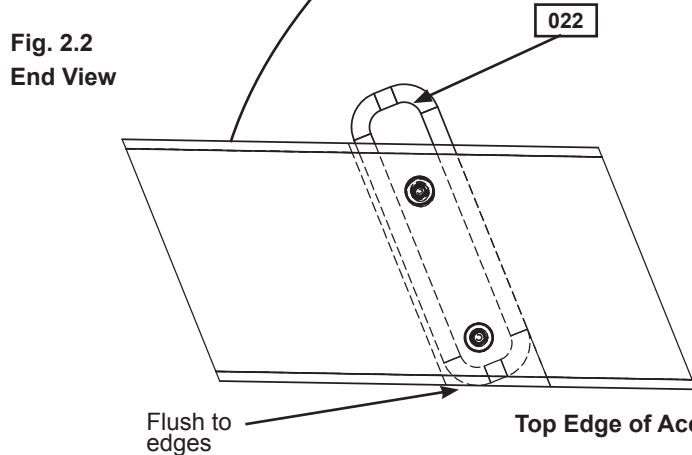
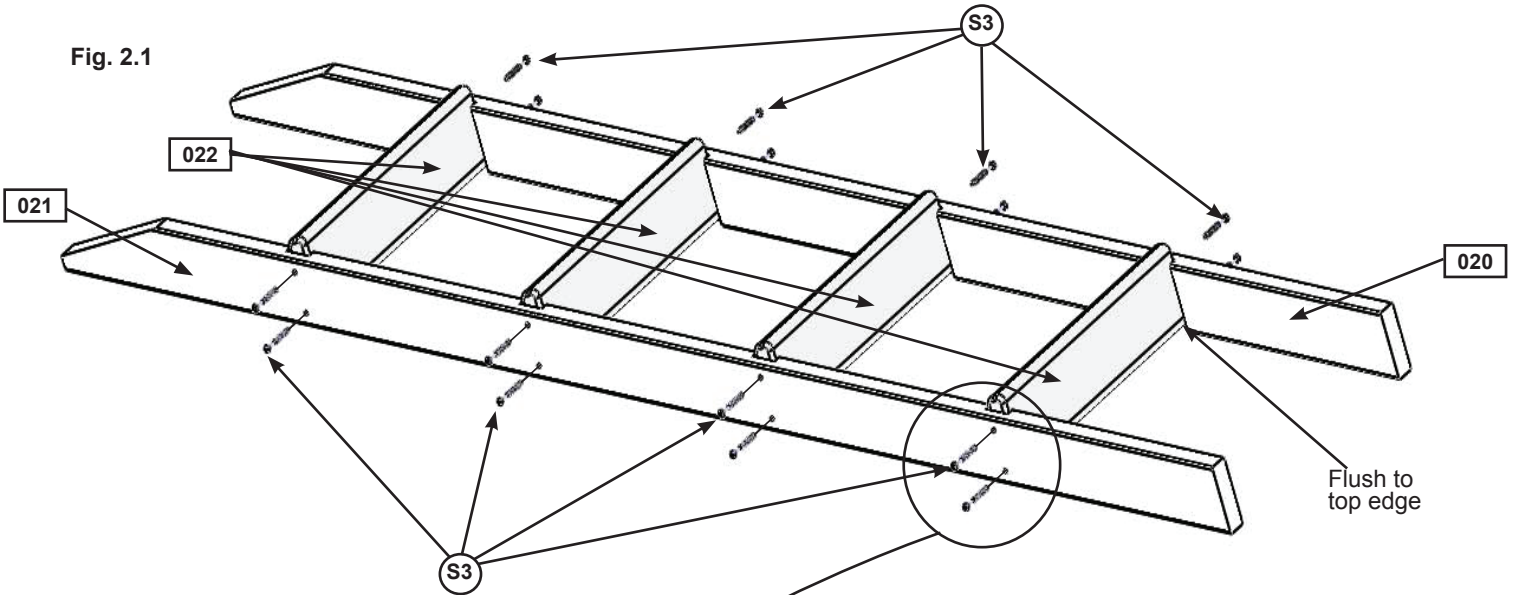

**Wood Parts**

- 1 x (020) Left Access 1-3/8 x 2-1/2 x 57-7/8"
- 1 x (021) Right Access 1-3/8 x 2-1/2 x 57-7/8"
- 4 x (022) Tread 5/4 x 4 x 19-1/2"

**Hardware**

- 16 x (S3) #8 x 2-1/2" Wood Screw

# Step 2: Access Ladder / Rockwall Assembly

## Part 2



**D:** Place (023) Ladder Gap on each access rail so there is a 2-3/8" gap between (023) Ladder Gap and the top (022) Tread. Attach using 4 (S11) #8 x 2" Wood Screws. (fig. 2.3)

**E:** Place (024) Rock Rail on the ground next to (020) Left Access so it matches the orientation of the two access rails as shown in fig. 2.3. Attach (025) RW-AL Support flush to the top of Access Ladder assembly and (024) Rock Rail using 3 (S20) #8 x 1-3/8" Wood Screws in the top holes and 3 (S11) #8 x 2" Wood Screws in the bottom holes. Pilot holes in (025) RW-AL Support should be centred over the rails. (fig. 2.3)

Fig. 2.3

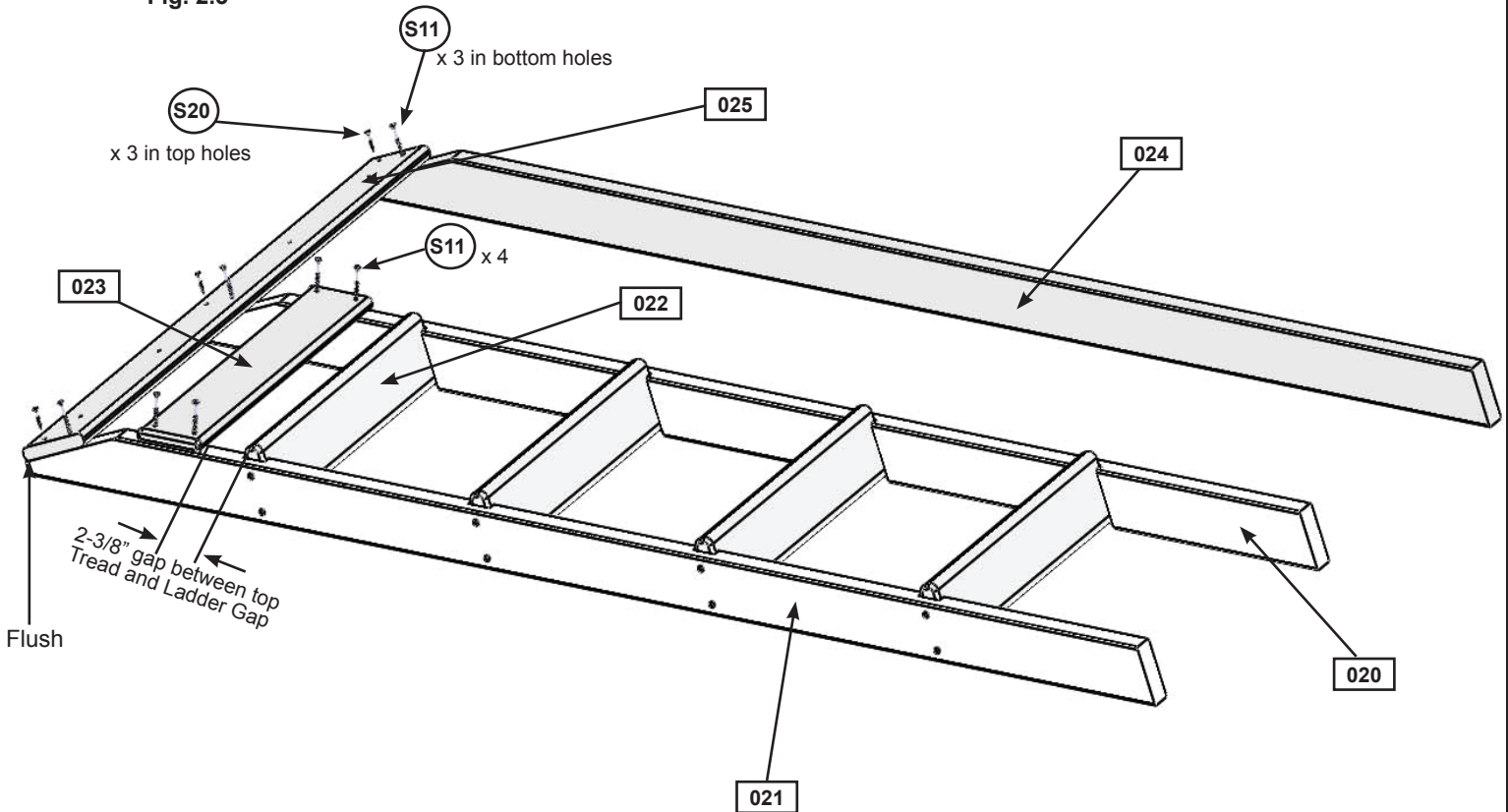

### Wood Parts

- 1 x 023 Ladder Gap 1 x 4 x 21"
- 1 x 024 Rock Rail 1-3/8 x 2-1/2 x 57-7/8"
- 1 x 025 RW-AL Support 1 x 4 x 41-3/4"

### Hardware

- 7 x S11 #8 x 2" Wood Screw
- 3 x S20 #8 x 1-3/8" Wood Screw

# Step 3: Rockwall Assembly Part 1



**A:** Place (031) Access Board flush to the top of the Access Ladder/Rockwall Assembly and (030) Access Rock Bottom at the bottom of the assembly as shown in fig. 3.1. Then place (032) Board Rock A and (033) Board Rock B as shown in fig. 3.1. Do not screw boards down yet. Rock holes are to be staggered so they do not form a straight line and are at the top of the boards. **Note: Rock Boards are to be flush to (020) Left Access and pilot holes are centred over (024) Rock Rail. (fig. 3.1)**

**B:** Make sure all boards are tight together and the assembly is square, then attach all boards except for (031) Access Board using 4 (S20) #8 x 1-3/8" Wood Screws per board. (031) Access Board to be attached in Step 10, Part 2, keep aside until needed. (fig. 3.1)

Fig. 3.1

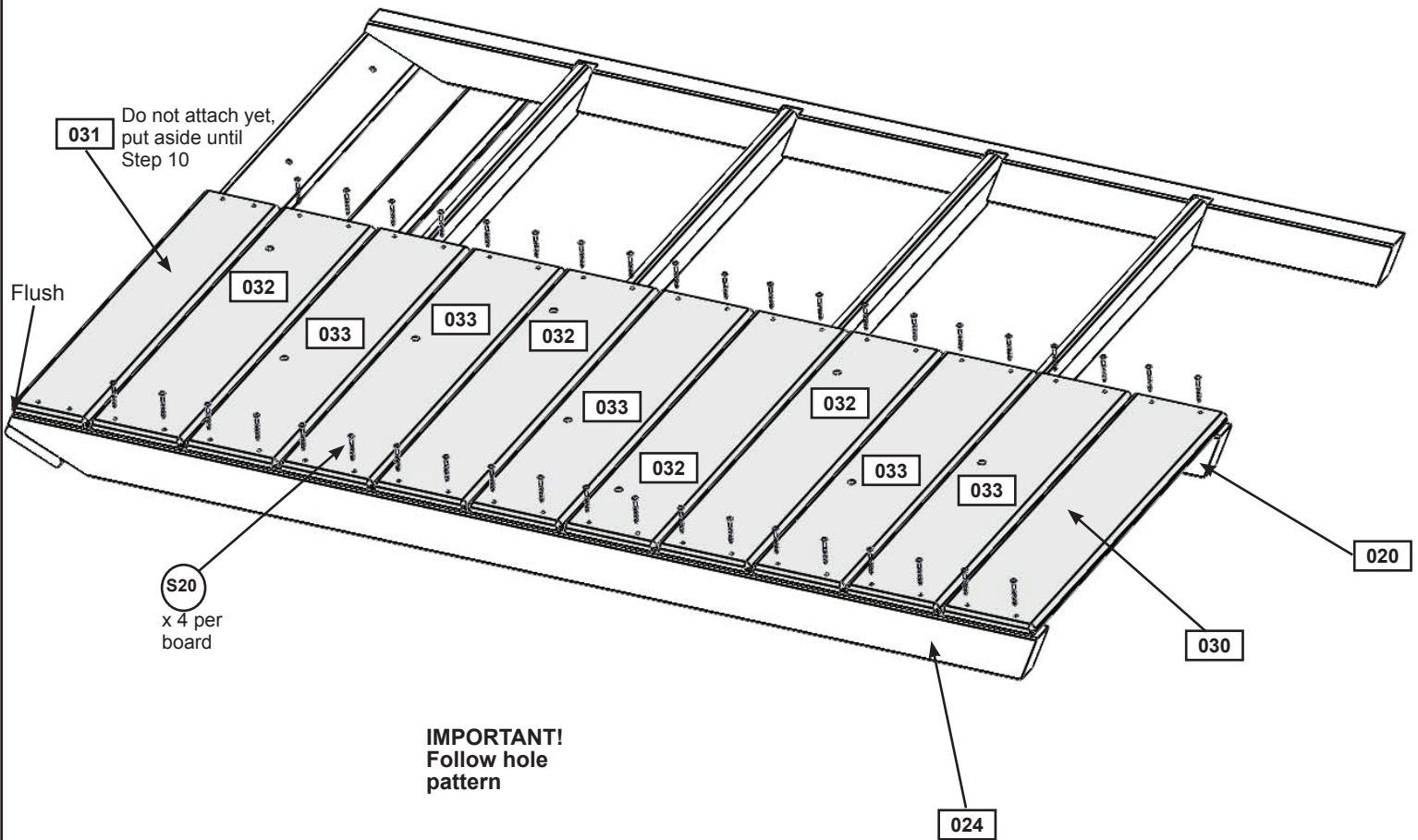

### Wood Parts

- 1 x **030** Access Rock Bottom 1 x 6 x 22-1/8"
- 1 x **031** Access Board 1 x 5 x 22-1/8"
- 4 x **032** Board Rock A 1 x 6 x 22-1/8"
- 5 x **033** Board Rock B 1 x 6 x 22-1/8"

### Hardware

- 40 x **S20** #8 x 1-3/8" Wood Screw

# Step 3: Rockwall Assembly Part 2

**C:** Alternating colours and shapes, attach 1 rock to each rock board using 1 (PB2) 1/4 x 1-1/4" Pan Bolt (with lock washer, flat washer and barrel nut) and 1 (S10) #8 x 1" Pan Screw per rock. (fig. 3.2 and 3.3)

The Pan Screw is placed in the hole beneath the Pan Bolt. (fig. 3.2 and 3.3)

**Note:** Make sure all hardware is used to secure each rock properly.

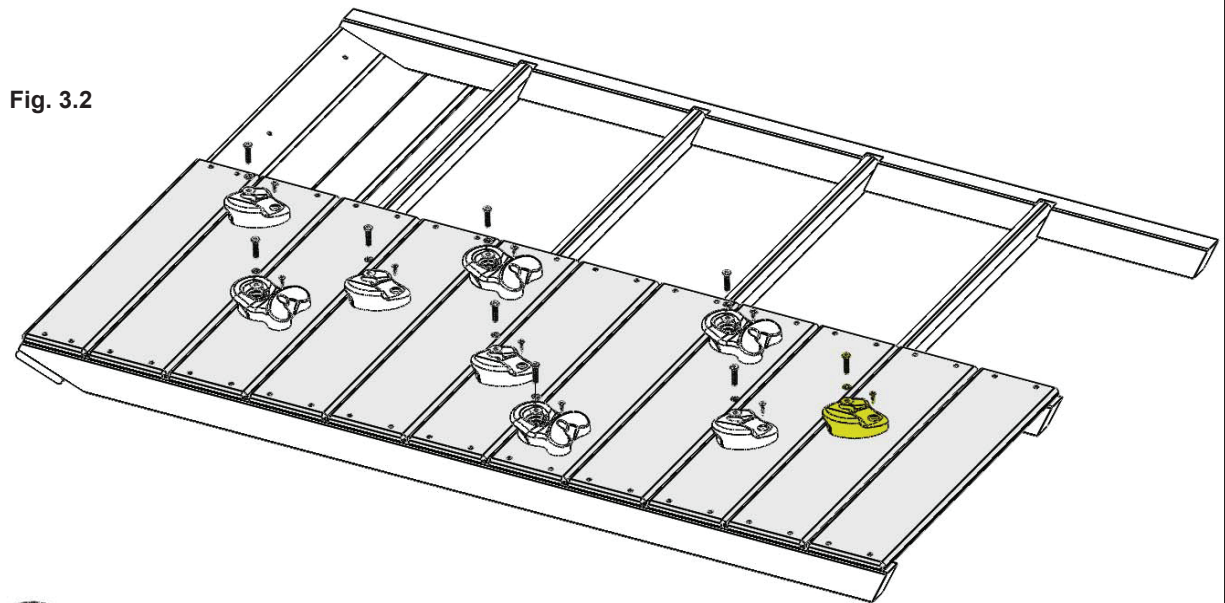

Fig. 3.2

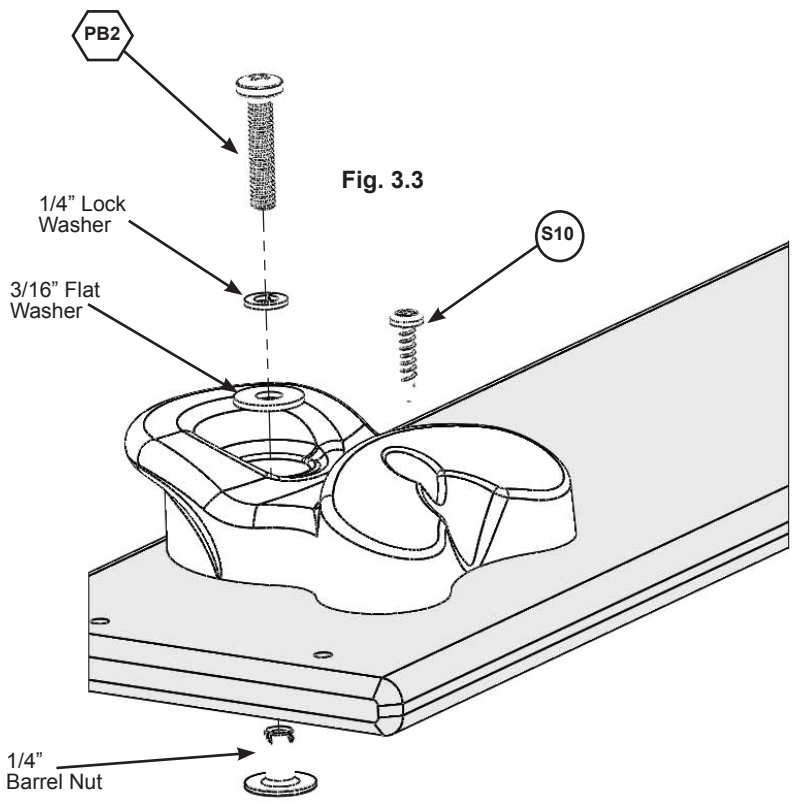



Fig. 3.3

### Hardware

- 9 x  1/4 x 1-1/4 Pan Bolt  
(1/4" lock washer, 3/16" flat washer & 1/4" barrel nut)
- 9 x  #8 x 1" Pan Screw

### Other Parts

- 9 x Rocks (green/yellow/burgundy)



# Step 4: Slide Wall Assembly

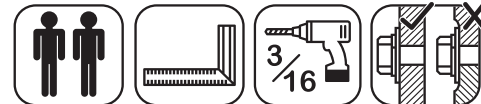

**A:** Place (041) Narrow Back Panel against the left side of (040) Slide End Panel noticing panel orientation. The tops and bottoms of the panels should be flush and panels square. Pre-drill with a 3/16" drill bit, then fasten (041) Narrow Back Panel to (040) Slide End Panel with 4 (WL5) 1/4 x 2-1/2" Wafer Lags. (fig. 4.1 and 4.2)

**B:** Place (042) Narrow Front Panel against the right side of (040) Slide End Panel noticing panel orientation. The tops and bottoms of the panels should be flush and panels square. Pre-drill with a 3/16" drill bit, then fasten (040) Slide End Panel to (042) Narrow Front Panel with 4 (WL5) 1/4 x 2-1/2" Wafer Lags. (fig. 4.1 and 4.3)

Fig. 4.2

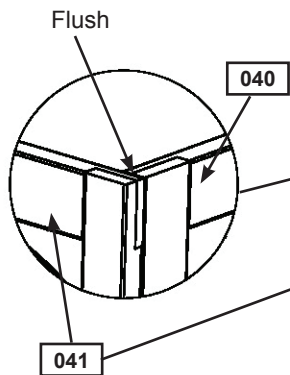

Notice (041) Narrow Back Panel overlaps (040) Slide End Panel

Fig. 4.1

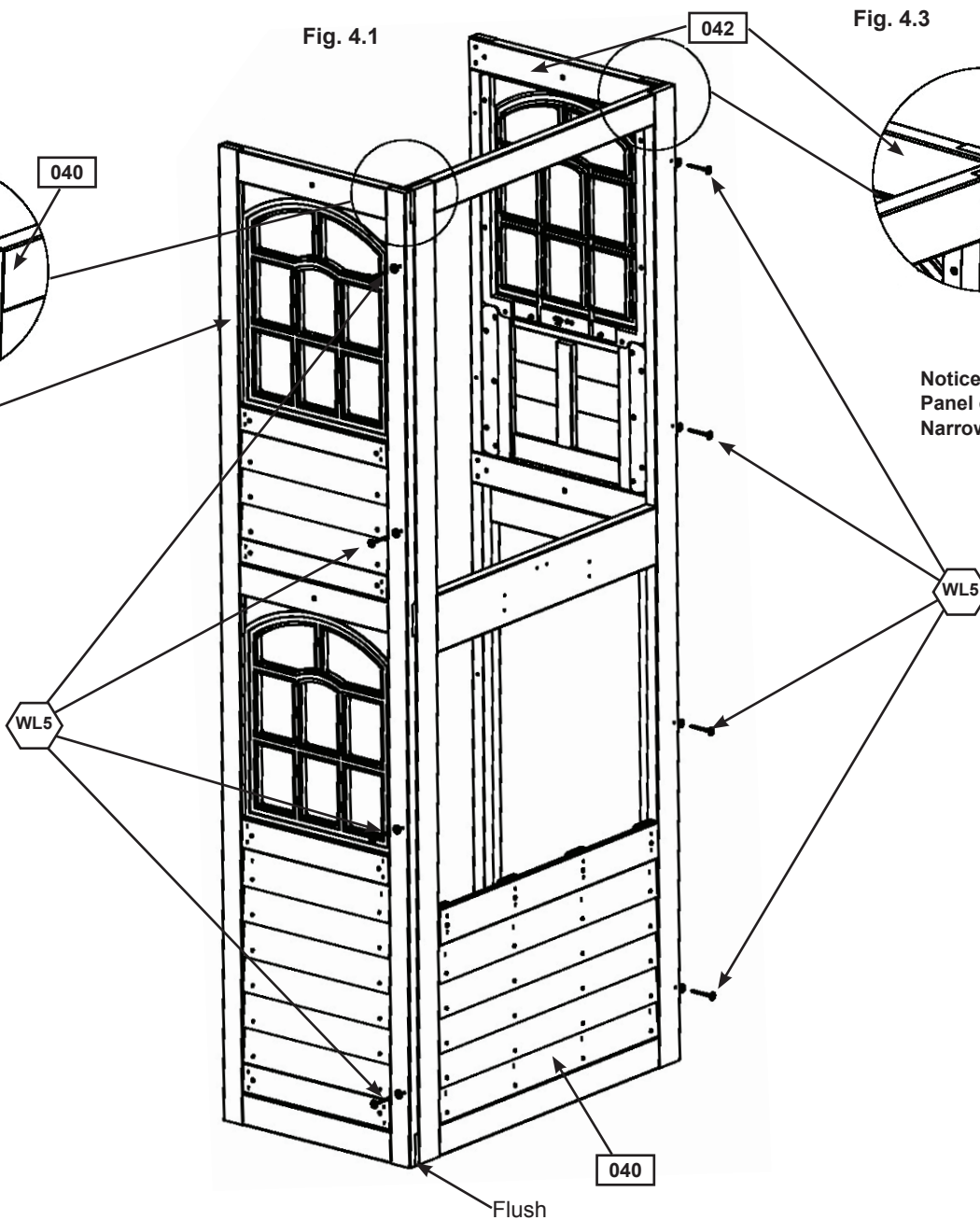
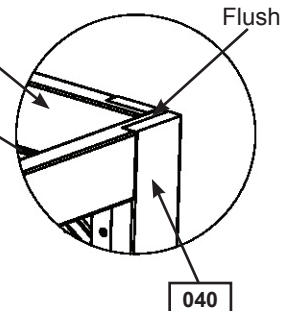

Fig. 4.3



Notice (040) Slide End Panel overlaps (042) Narrow Front Panel

### Wood Parts

- 1 x 040 Slide End Panel 1-1/4 x 37 x 92"
- 1 x 041 Narrow Back Panel 1-1/4 x 21-1/2 x 92"
- 1 x 042 Narrow Front Panel 1-1/4 x 21-1/2 x 92"

### Hardware

- 8 x WL5 1/4 x 2-1/2" Wafer Lag



# Step 5: Swing Wall Assembly

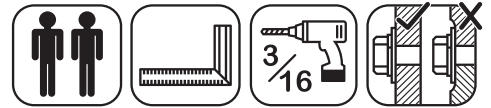

**A:** Place (051) Front Wall Panel against the left side of (050) SW Wall Panel noticing panel orientation. The tops and bottoms of the panels should be flush and panels square. Pre-drill with a 3/16" drill bit, then fasten (051) Front Wall Panel to (050) SW Wall Panel with 4 (WL5) 1/4 x 2-1/2" Wafer Lags. (fig. 5.1 and 5.2)

**B:** Place (052) Back Wall Panel against the right side of (050) SW Wall Panel noticing panel orientation. The tops and bottoms of the panels should be flush and panels square. Pre-drill with a 3/16" drill bit, then fasten (050) SW Wall Panel to (052) Back Wall Panel with 4 (WL5) 1/4 x 2-1/2" Wafer Lags. (fig. 5.1 and 5.3)

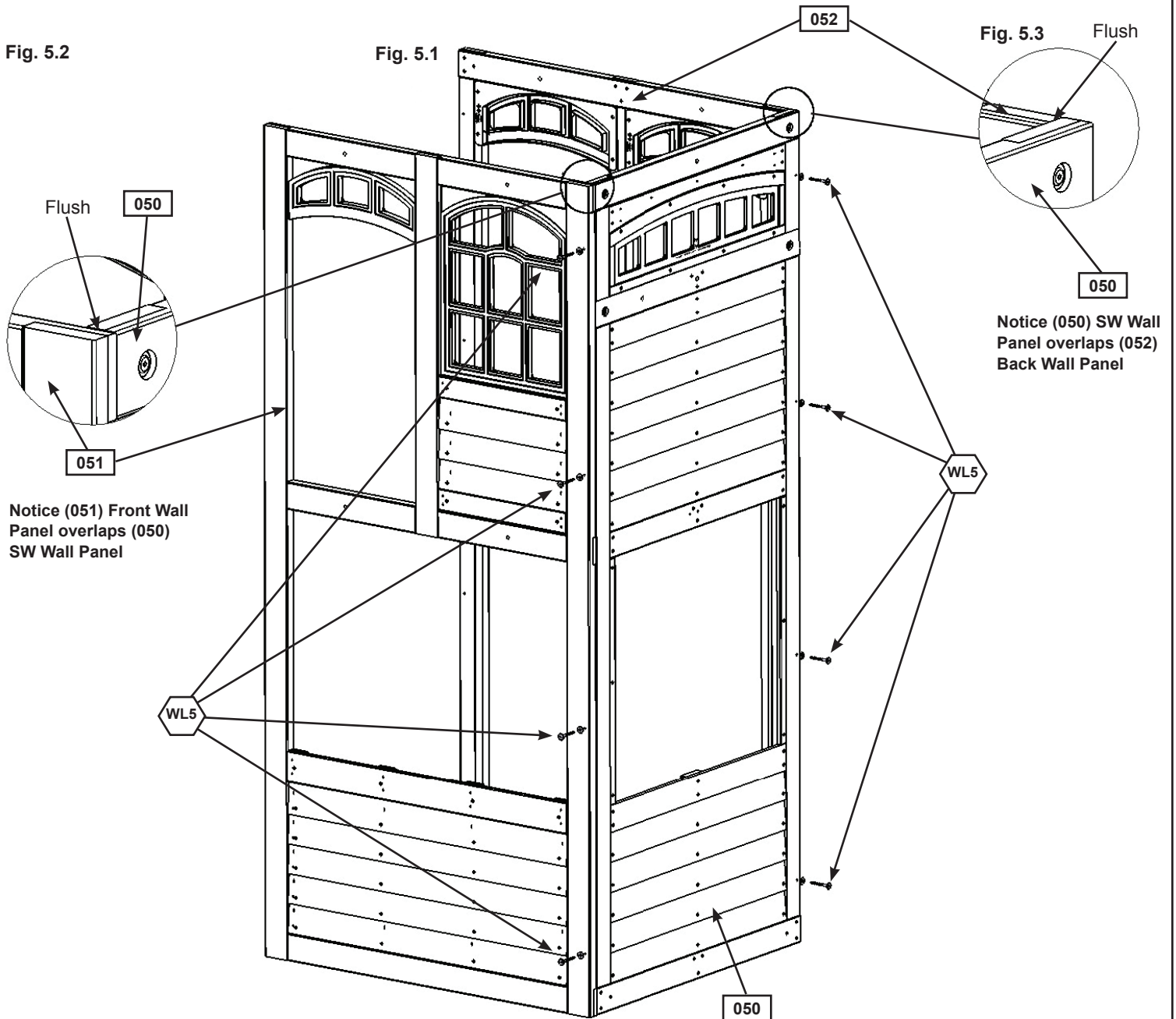

### Wood Parts

- 1 x 050 SW Wall Panel 1-1/4 x 37 x 92"
- 1 x 051 Front Wall Panel 1-1/4 x 43 x 92"
- 1 x 052 Back Wall Panel 1-1/4 x 43 x 92"

### Hardware

- 8 x WL5 1/4 x 2-1/2" Wafer Lag

# Step 6: Join Swing and Slide Wall Assemblies Part 1

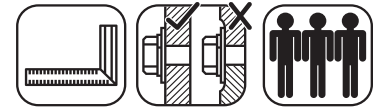

**A:** With at least two helpers lift the Slide Wall Assembly and Swing Wall Assembly so the (041) Narrow Back Panel and (042) Narrow Front Panel meet with (052) Back Wall Panel and (051) Front Wall Panel and are tight together as shown in fig. 6.1.

**B:** Make sure the assembly is square then on the inside of the assembly, tight to (040) Slide End Panel and flush to the bottom of the panels attach 1 (060) Floor Joist to (041) Narrow Back Panel and (052) Back Wall Panel and a second (060) Floor Joist to (042) Narrow Front Panel and (051) Front Wall Panel with 4 (S7) #12 x 2" Pan Screws per board. (fig. 6.1 and 6.2)

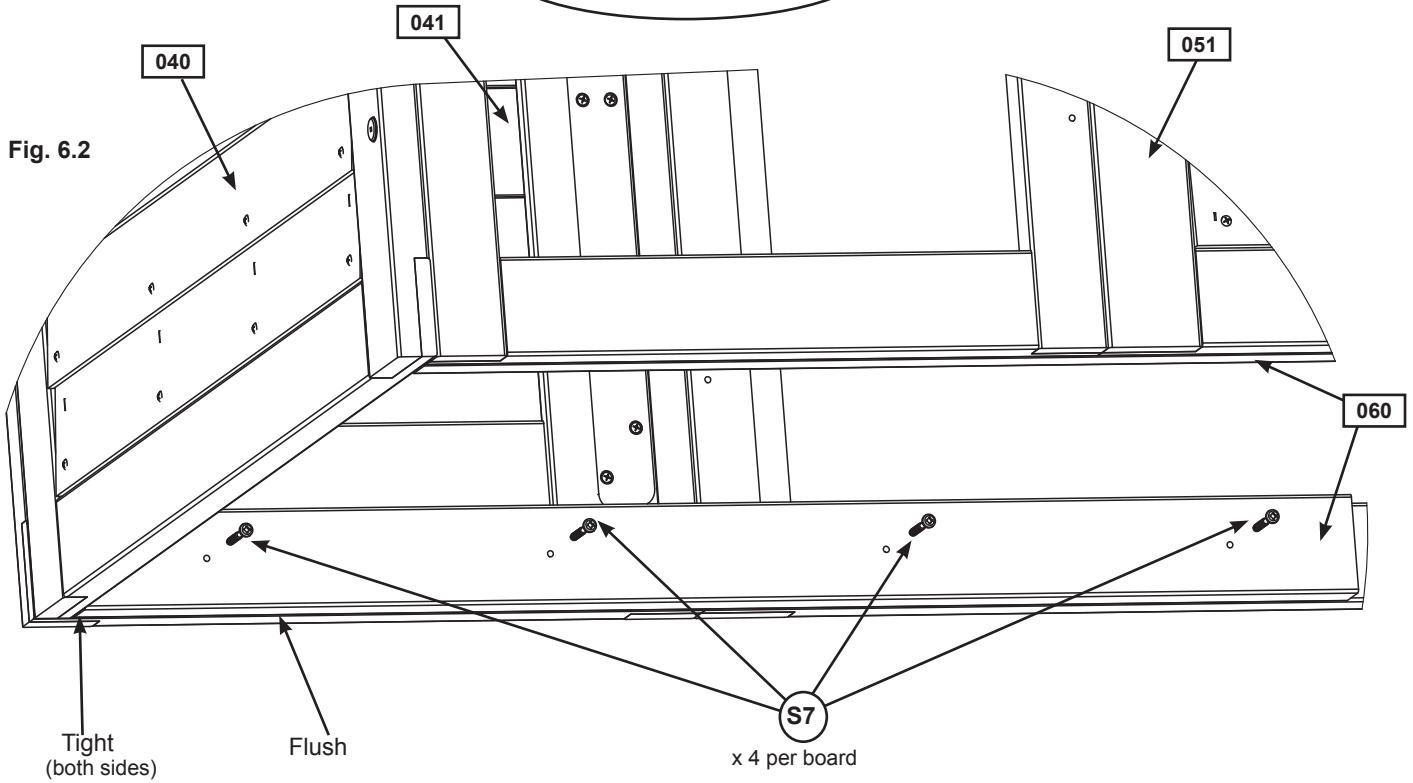
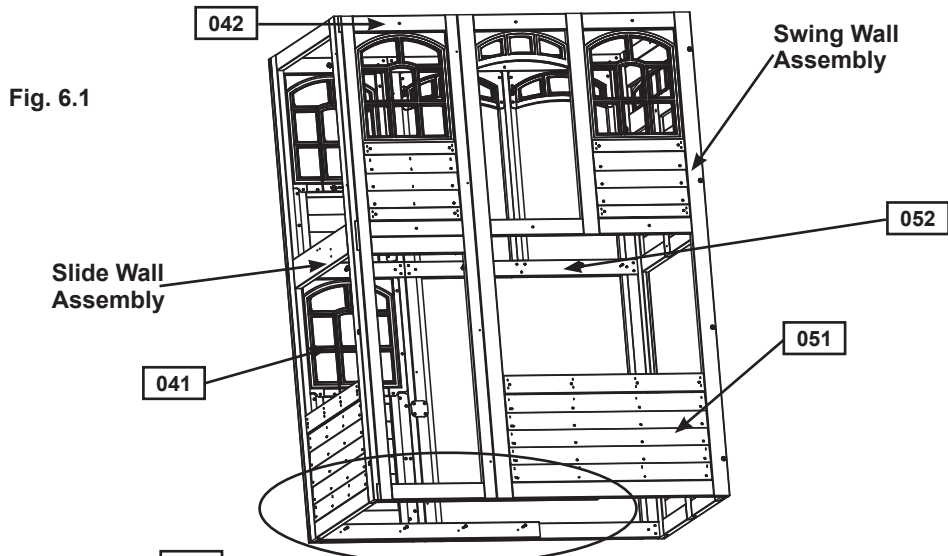

**Wood Parts**

2 x 060 Floor Joist 1-1/4 x 3 x 40-3/4"

**Hardware**

8 x S7 #12 x 2" Pan Screw

# Step 6: Join Swing and Slide Wall Assemblies Part 2



**C:** From inside the assembly, tight to both (040) Slide End Wall and (050) SW Wall Panel, halfway up the assembly, 5/8" below the panel, loosely attach 1 (061) Side Joist to (041) Narrow Back Panel and (052) Back Wall Panel with 3 (WB10) 5/16 x 2-5/8" Wafer Bolts (with flat washer and t-nut). Bolts are installed from inside the assembly. Make sure (061) Side Joist is level then attach with 2 (S3) #8 x 2-1/2" Wood Screws and tighten bolts. (fig. 6.3, 6.4 and 6.5)

**D:** Repeat Step C to attach 1 (061) Side Joist to (042) Narrow Front Panel and (051) Front Wall Panel. (fig. 6.3 and 6.4)

Fig. 6.3

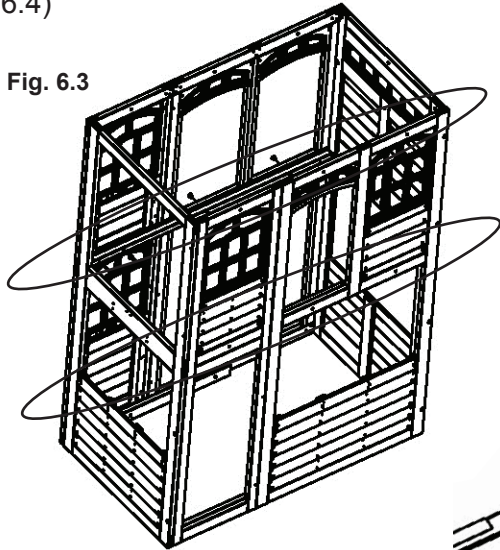

Fig. 6.4  
Inside View

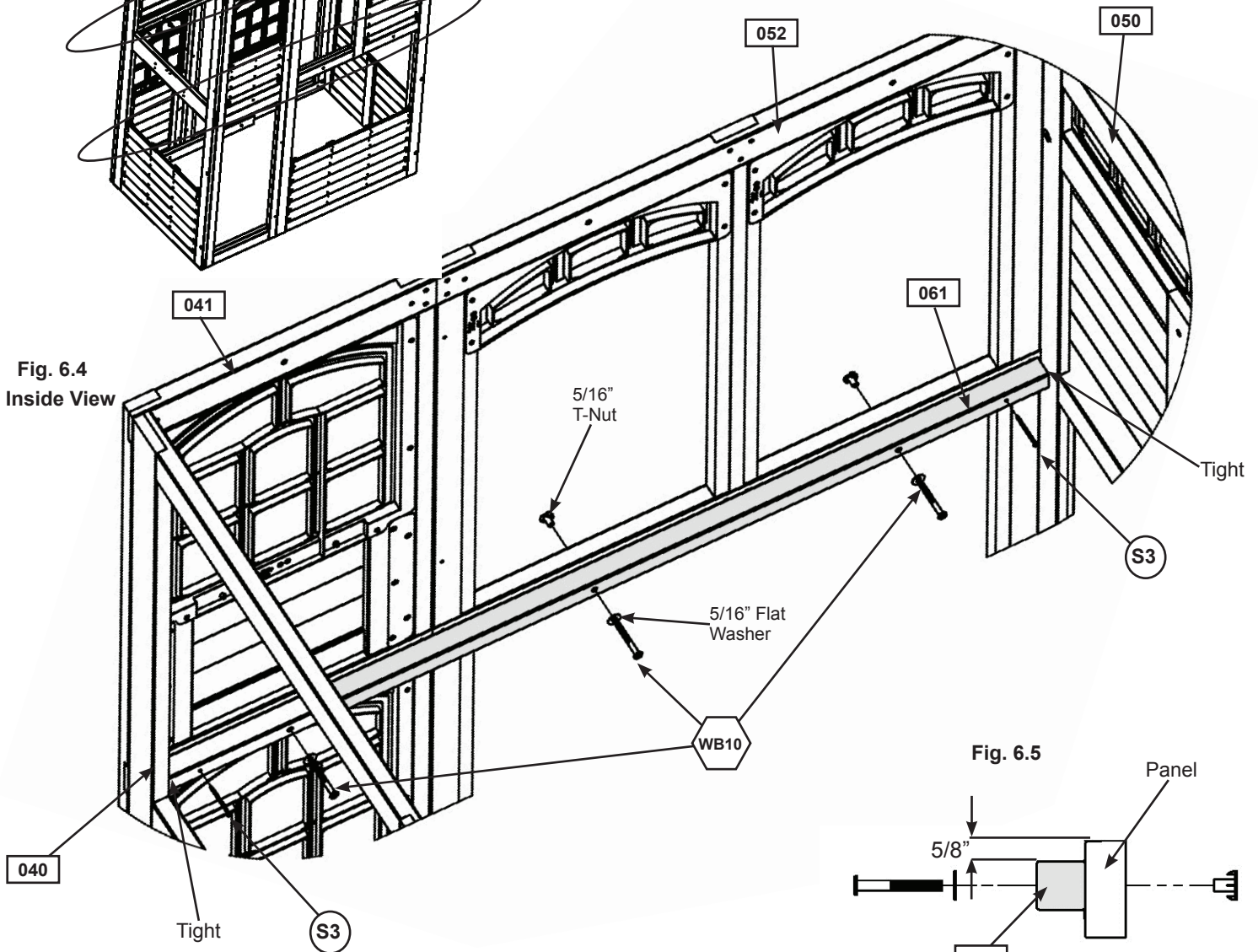
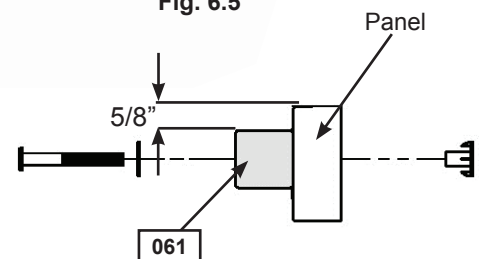

Fig. 6.5



### Wood Parts

2 x 061 Side Joist 2 x 2 x 63"

### Hardware

4 x S3 #8 x 2-1/2" Wood Screw

6 x WB10 5/16 x 2-5/8" Wafer Bolt  
(5/16" flat washer, 5/16" t-nut)

# Step 6: Join Swing and Slide Wall Assemblies Part 3

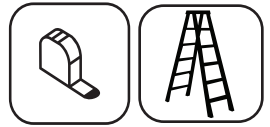

**E:** From outside the assembly, place 1 (062) Roof Support against (041) Narrow Back Panel and (052) Back Wall Panel so it sits  $3/4$ " above the panels and has approximately  $3-1/16$ " overhang at each corner then attach with 3 (WB8)  $5/16$  x  $2-3/8$ " Wafer Bolts (with flat washer and t-nut) . (fig. 6.6 and 6.7)

**F:** Repeat Step E to attach 1 (062) Roof Support to (042) Narrow Front Panel and (051) Front Wall Panel. (fig. 6.6 and 6.7)

Fig. 6.6

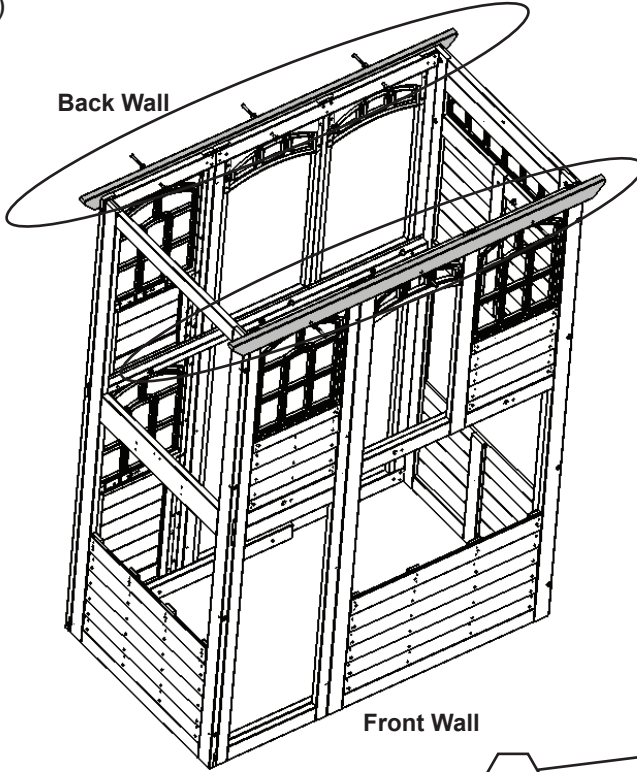
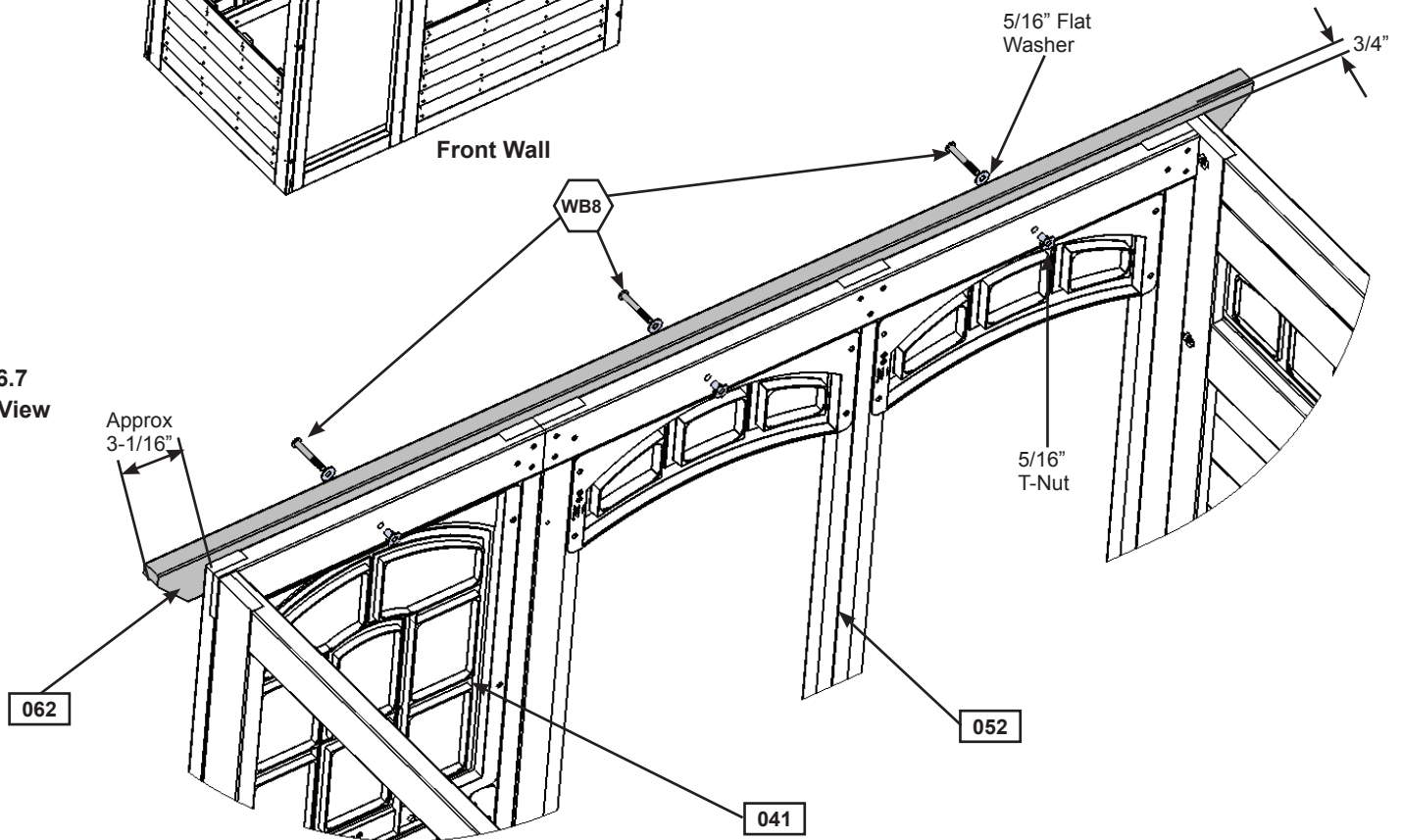

Fig. 6.7  
Inside View



**Wood Parts**

2 x **062** Roof Support 1-1/4 x 3 x 72"

**Hardware**

6 x **WB8**  $5/16$  x  $2-3/8$ " Wafer Bolt  
( $5/16$ " flat washer,  $5/16$ " t-nut)



# Step 6: Join Swing and Slide Wall Assemblies Part 4

**G:** On the inside of the assembly attach (041) Narrow Back Panel to (052) Back Wall Panel using 2 Flat Panel Brackets in the places shown with 4 (S8) #12 x 3/4" Pan Screws per bracket. (fig. 6.8 and 6.9)

**H:** Repeat Step G to attach (042) Narrow Front Panel to (051) Front Wall Panel. (fig. 6.8 and 6.9)

**I:** At all four corners, both top and bottom, attach 1 Panel Corner Bracket with 4 (S8) #12 x 3/4" Pan Screws per bracket. Brackets to be flush to the top and bottom of the panels. (fig. 6.8 and 6.10)

Fig. 6.8

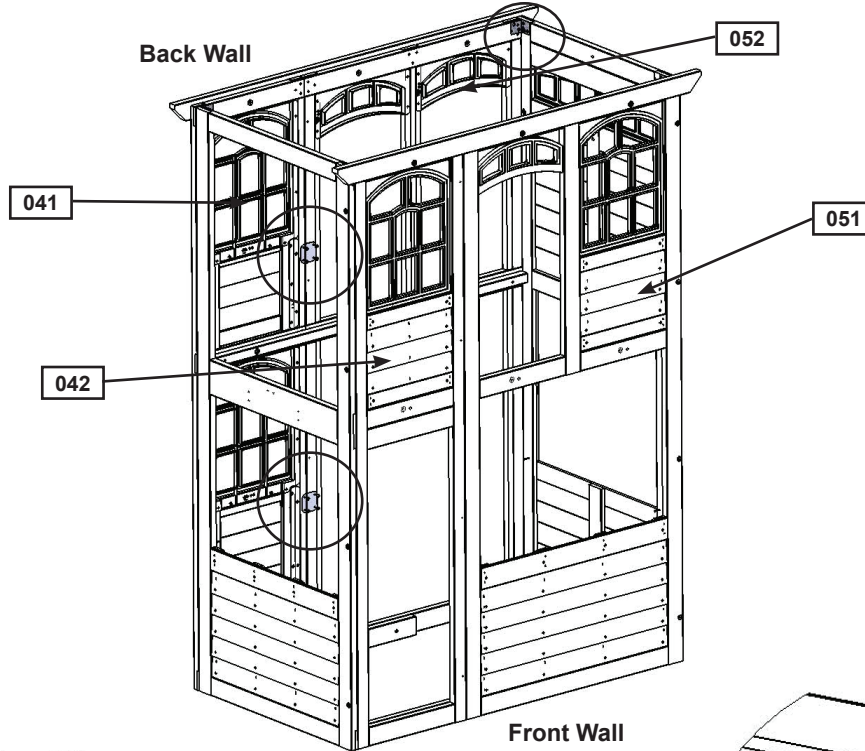

Fig. 6.9  
Inside View

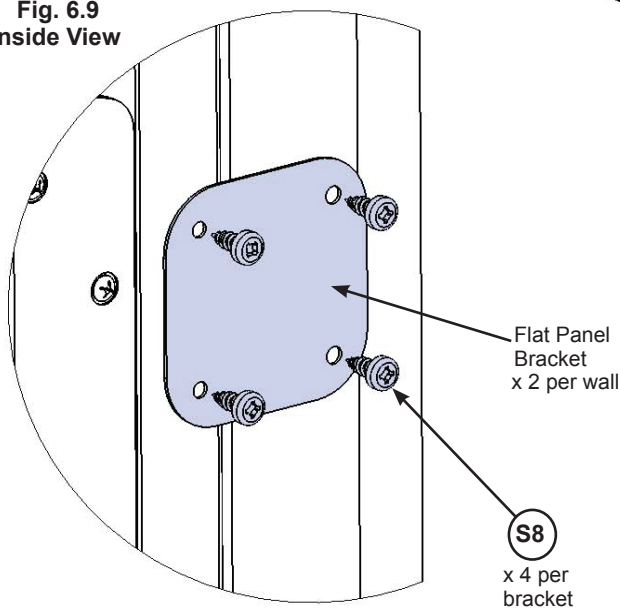
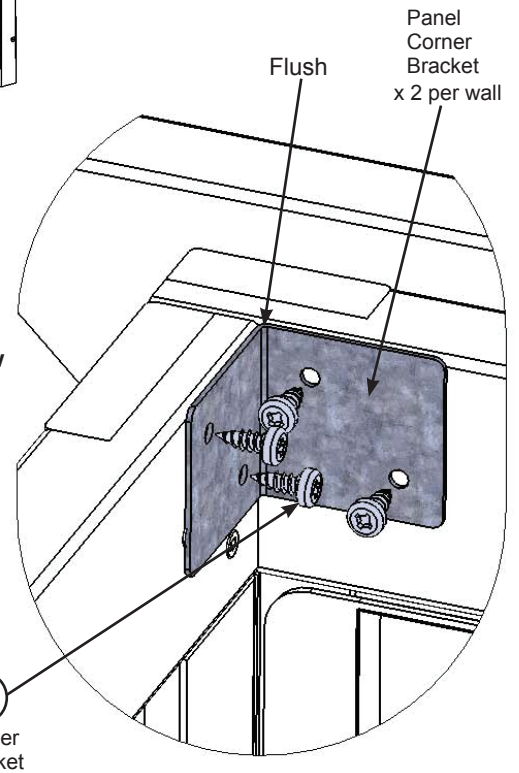

Fig. 6.10  
Inside View



### Hardware

48 x (S8) #12 x 3/4" Pan Screw

### Other Parts

4 x Flat Panel Bracket  
8 x Panel Corner Bracket



# Step 7: Floor Assembly Part 1



**A:** Place 1 (070) Floor Board tight to (040) Slide End Panel and 1 tight to (050) SW Wall Panel then attach each to the (061) Side Joists with 4 (S20) #8 x 1-3/8" Wood Screws per board. (fig. 7.1 and 7.2)

**B:** Place (071) Long Floor Joist tight to the bottom of each (070) Floor Board, centred over the pilot holes on the (040) Slide End Panel and (050) SW Wall Panel then attach with 2 (S4) #8 x 3" Wood Screws per panel. Attach (070) Floor Board to (071) Long Floor Joist with 2 (S20) #8 x 1-3/8" Wood Screws per board (fig. 7.1, 7.2 and 7.3)

Fig. 7.2

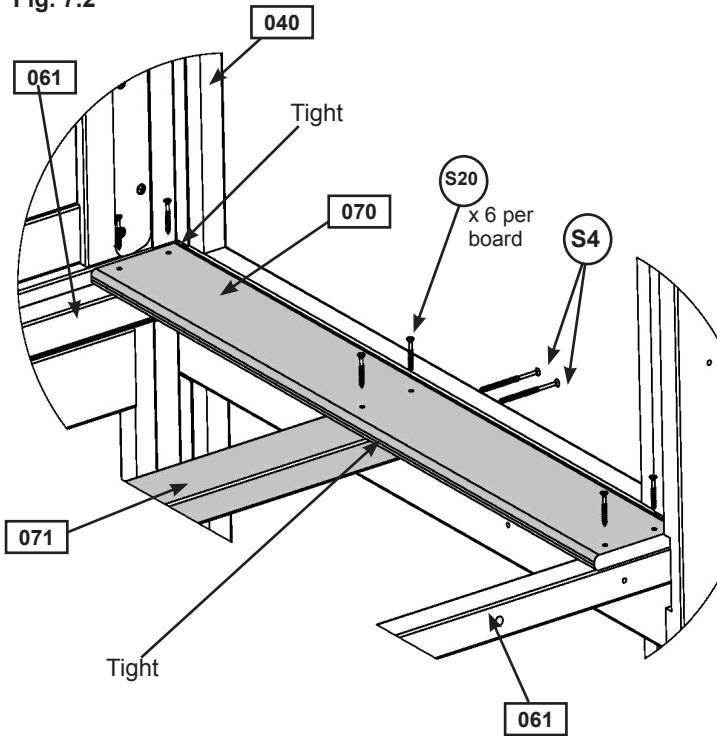

Fig. 7.1

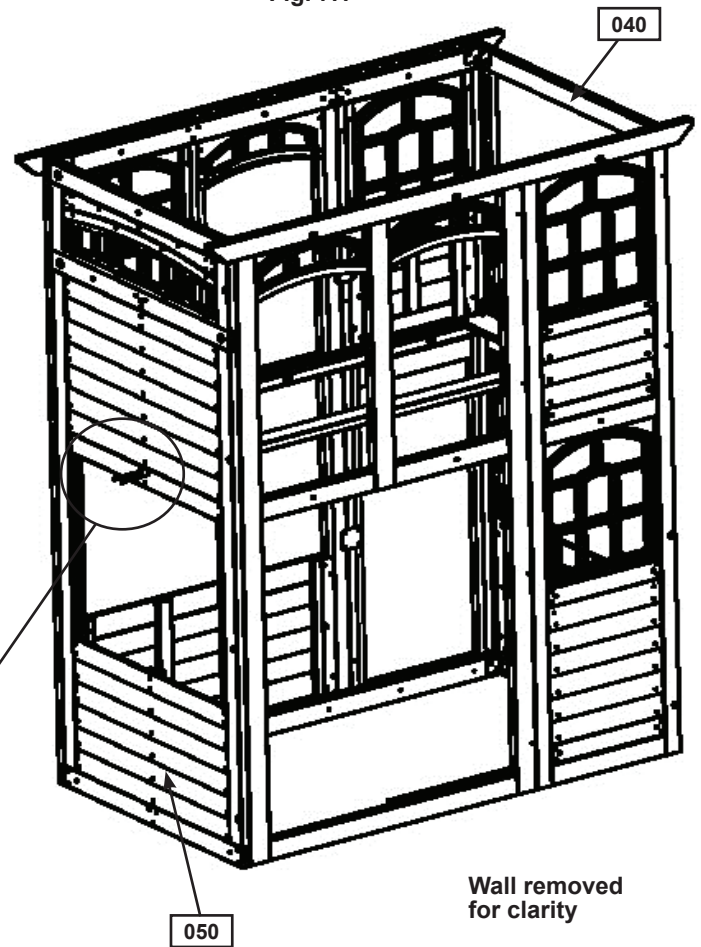
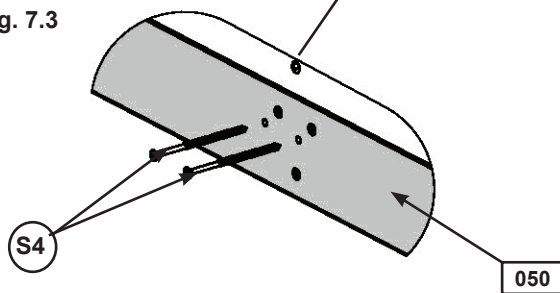

Fig. 7.3



### Wood Parts

- 2 x 070 Floor Board 1 x 5 x 35-5/8"
- 1 x 071 Long Floor Joist 1-1/4 x 3 x 63-1/4"

### Hardware

- 12 x S20 #8 x 1-3/8" Wood Screw
- 4 x S4 #8 x 3" Wood Screw

# Step 7: Floor Assembly Part 2



**C:** Measure the distance from the Back Wall to the Front Wall from the inside of the panels to make sure it equals 35-3/4". Maintain this measurement when installing the floor boards. Starting at the Slide Wall place 3 (070) Floor Boards tight to the previously attached (070) Floor Board, followed by 1 (072) Floor Board then 8 more (070) Floor Boards. Make sure all boards are equally spaced then attach to (071) Long Floor Joist and each (061) Side Joist with 6 (S20) #8 x 1-3/8" Wood Screws per board. (fig. 7.4, 7.5 and 7.6)

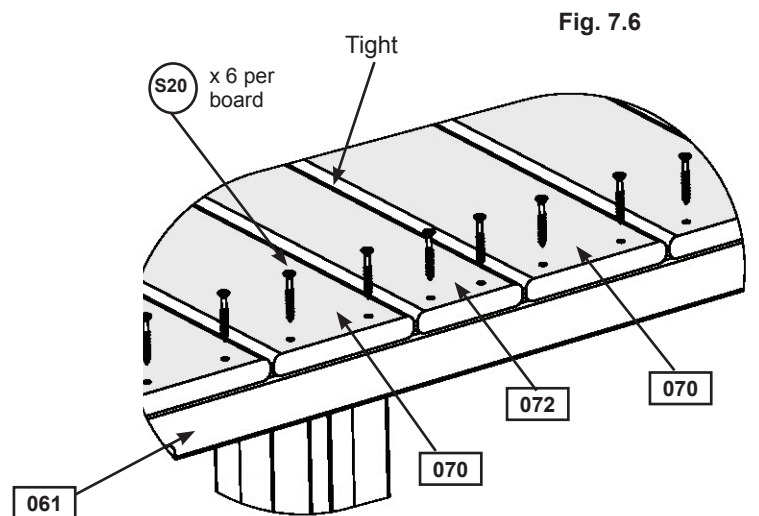
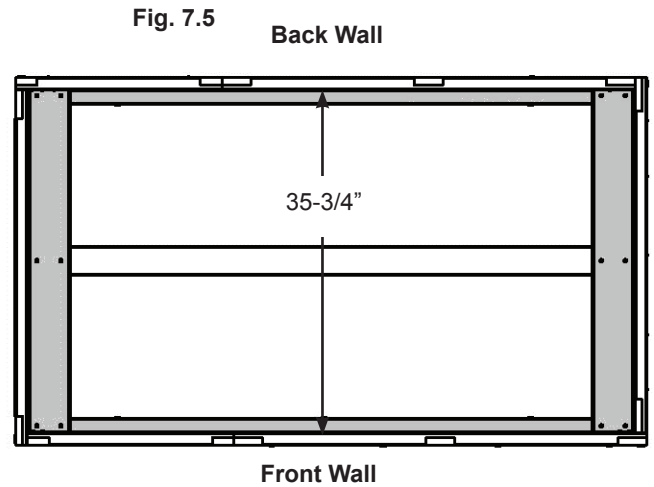
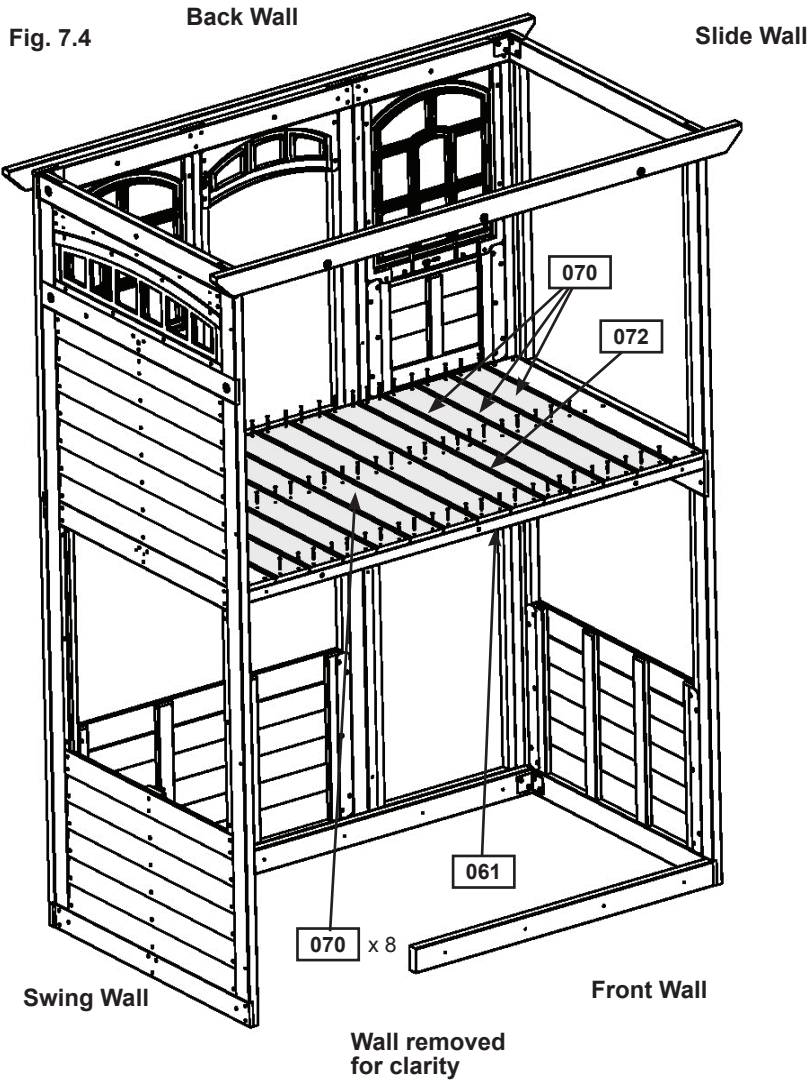

### Wood Parts

- 11 x 070 Floor Board 1 x 5 x 35-5/8"
- 1 x 072 Floor Board 1 x 4 x 35-5/8"

### Hardware

- 72 x S20 #8 x 1-3/8" Wood Screw

## Step 8: Attach Wall Tops

**A:** In the opening of (050) SW Wall Panel, from the inside, attach (080) SW Wall Top, tight to the corner of the panels with overhang facing in with 1 (S11) #8 x 2" Wood Screw at each end as shown in fig. 8.1 and 8.2.

**B:** Attach (080) SW Wall Top to slat in (050) SW Wall Panel with 1 Corner Bracket using 3 (S13) #6 x 5/8" Pan Screws. (fig. 8.1 and 8.3)

**C:** In the opening of (040) Slide End Panel, from the inside, attach (081) Half Wall Top, tight to the corner of the panels with overhang facing in with 1 (S11) #8 x 2" Wood Screw at each end as shown in fig. 8.1 and 8.2.

**D:** Attach (081) Half Wall Top to slats in (040) Slide End Panel with 2 Corner Bracket using 3 (S13) #6 x 5/8" Pan Screws per bracket. (fig. 8.1 and 8.3)

**Fig. 8.2**  
Inside View

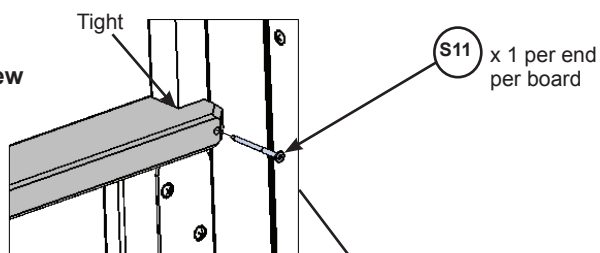

**Fig. 8.3**  
Inside View

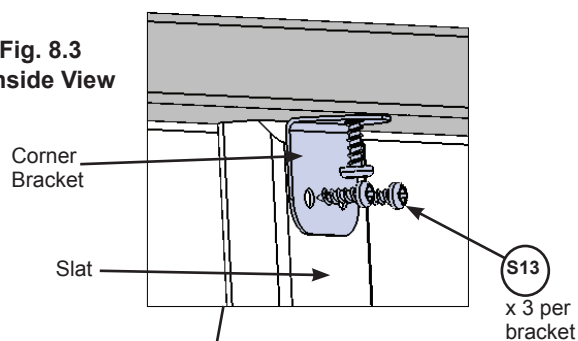

**Fig. 8.1**

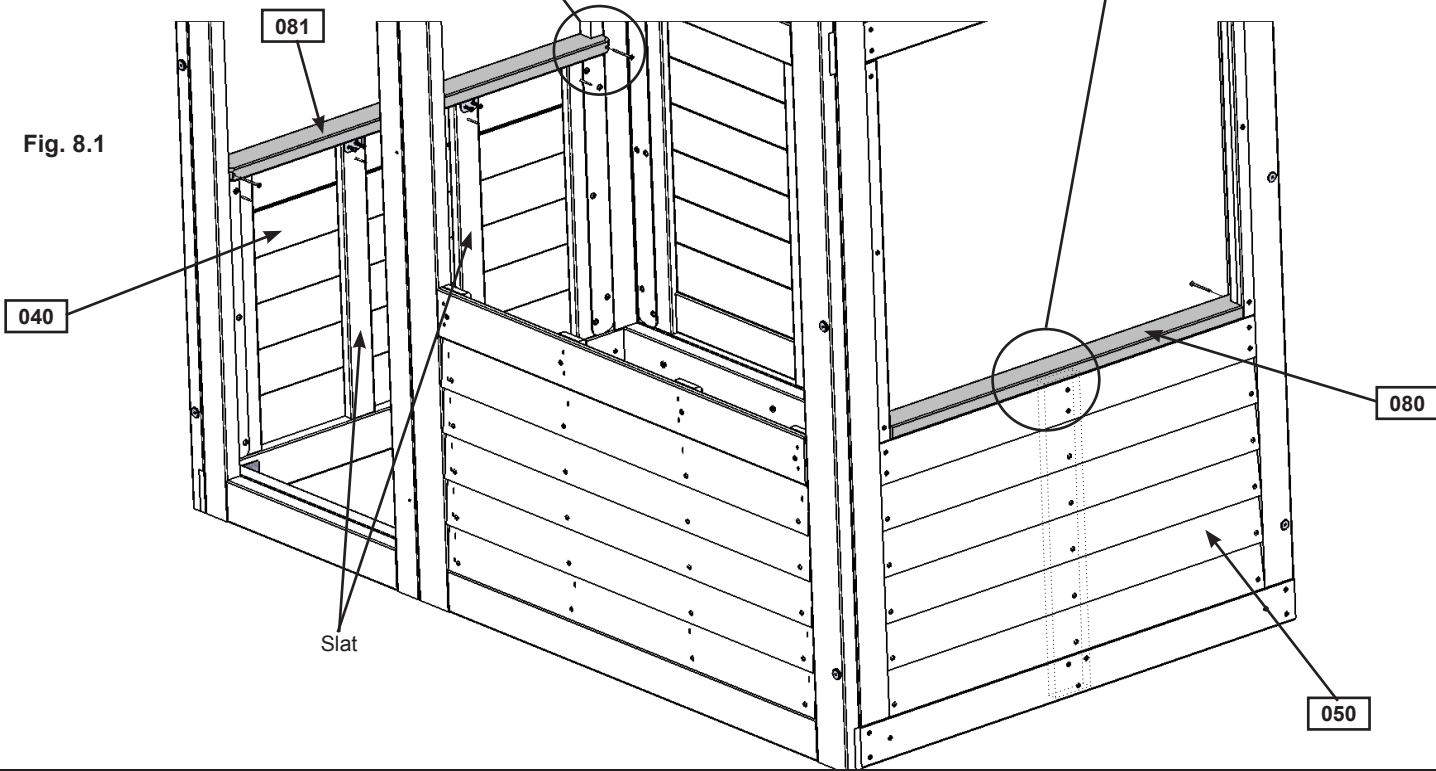

### Wood Parts

- 1 x **080** SW Wall Top 5/4 x 3 x 33-1/2"
- 1 x **081** Half Wall Top 5/4 x 3 x 33"

### Hardware

- 4 x **S11** #8 x 2" Wood Screw
- 9 x **S13** #6 x 5/8" Pan Screw

### Other Parts

- 3 x Corner Bracket

# Step 9: Attach SW Ground and Diagonal



**A:** Loosely attach (090) SW Ground to (091) Diagonal with 1 (WB9) 5/16 x 2-1/8" Wafer Bolt (with flat washer and t-nut) then place (091) Diagonal tight and flush to the front of (050) SW Wall Panel. (090) SW Ground to be flush to the bottom of (050) SW Wall Panel. (fig. 9.1 and 9.2)

**B:** Pre-drill pilot hole with a 3/16" drill bit then attach (091) Diagonal to (050) SW Wall Panel with 1 (WL5) 1/4 x 2-1/2" Wafer Lag (with flat washer), checking that it remains flush to outside edge. (fig. 9.1 and 9.2)

**C:** Making sure bottom of (090) SW Ground is flush to bottom of (050) SW Wall Panel pre-drill with a 1/8" drill bit then attach with 2 (S11) #8 x 2" Wood Screws and 1 (S4) #8 x 3" Wood Screw then tighten the bolt. (fig. 9.1 and 9.2)

Fig. 9.1

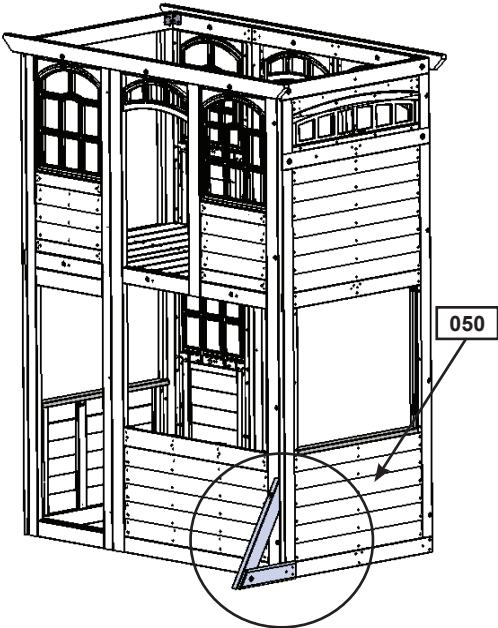
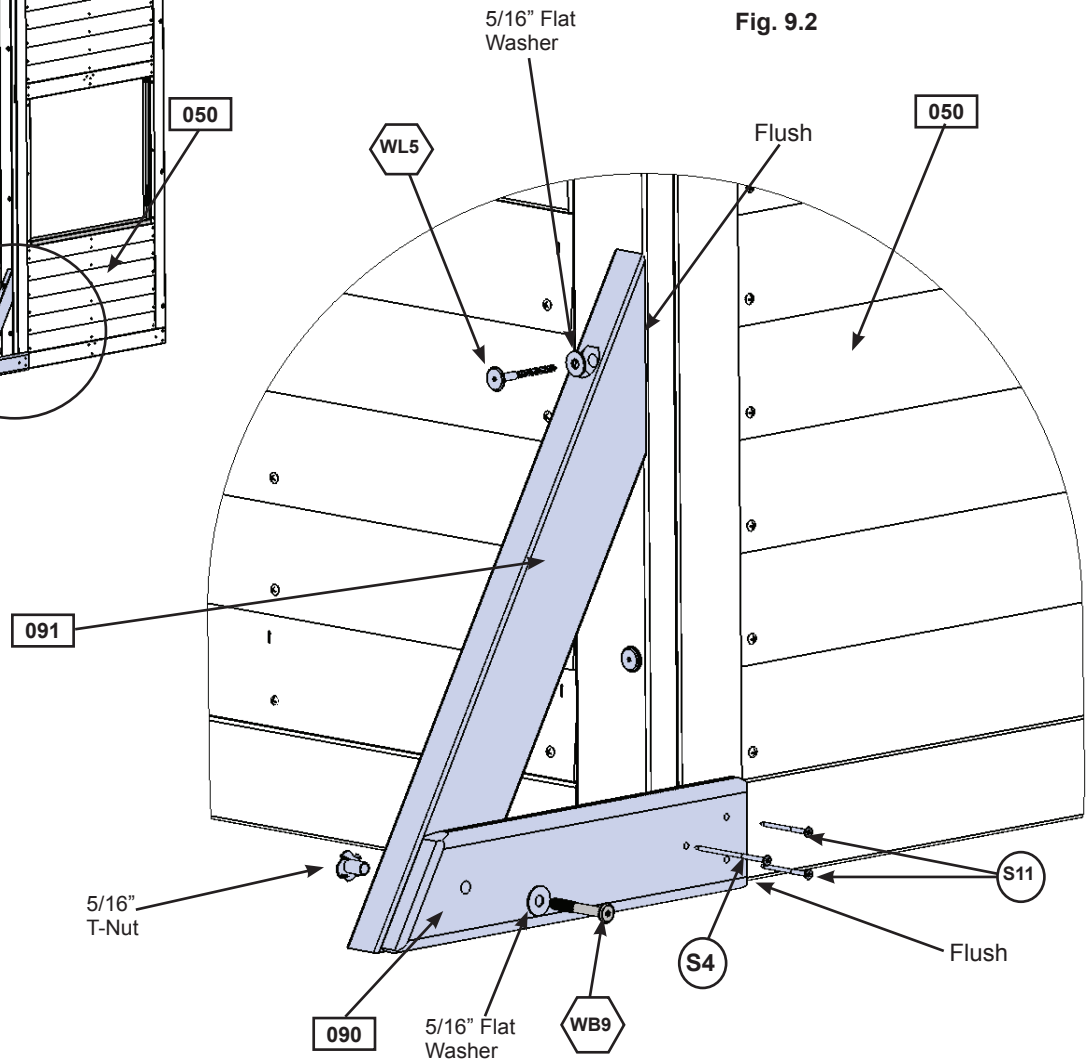

Fig. 9.2



### Wood Parts

- 1 x 090 SW Ground 5/4 x 4 x 14-1/4"
- 1 x 091 Diagonal 1-1/4 x 3 x 22"

### Hardware

- 1 x WB9 5/16 x 2-1/8" Wafer Bolt (5/16" flat washer, 5/16" t-nut)
- 1 x WL5 1/4 x 2-1/2" Wafer Lag (5/16" flat washer)
- 1 x S4 #8 x 3" Wood Screw
- 2 x S11 #8 x 2" Wood Screw

# Step 10: Attach Access Ladder/Rockwall Assembly Part 1

**A:** Place Access Ladder/Rockwall Assembly from Step 3 against (052) Back Wall Panel, flush to the outside edge and flush to the top of the floor boards then attach with 4 (S11) #8 x 2" Wood Screws. (fig. 10.1 and 10.2)

Fig. 10.1

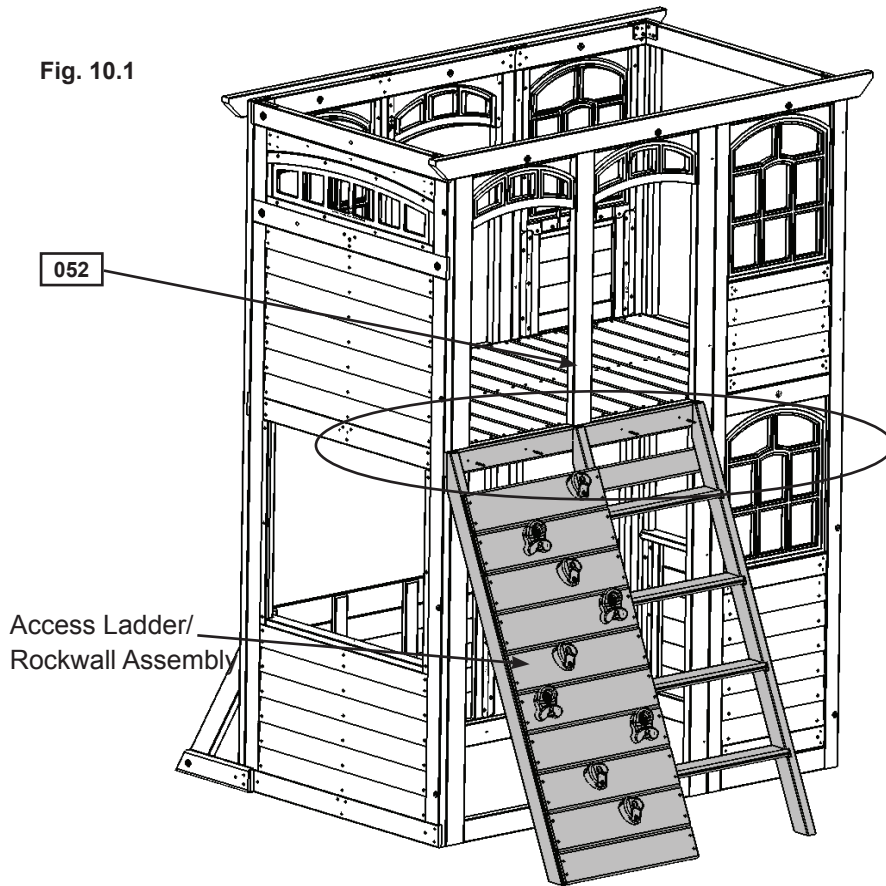
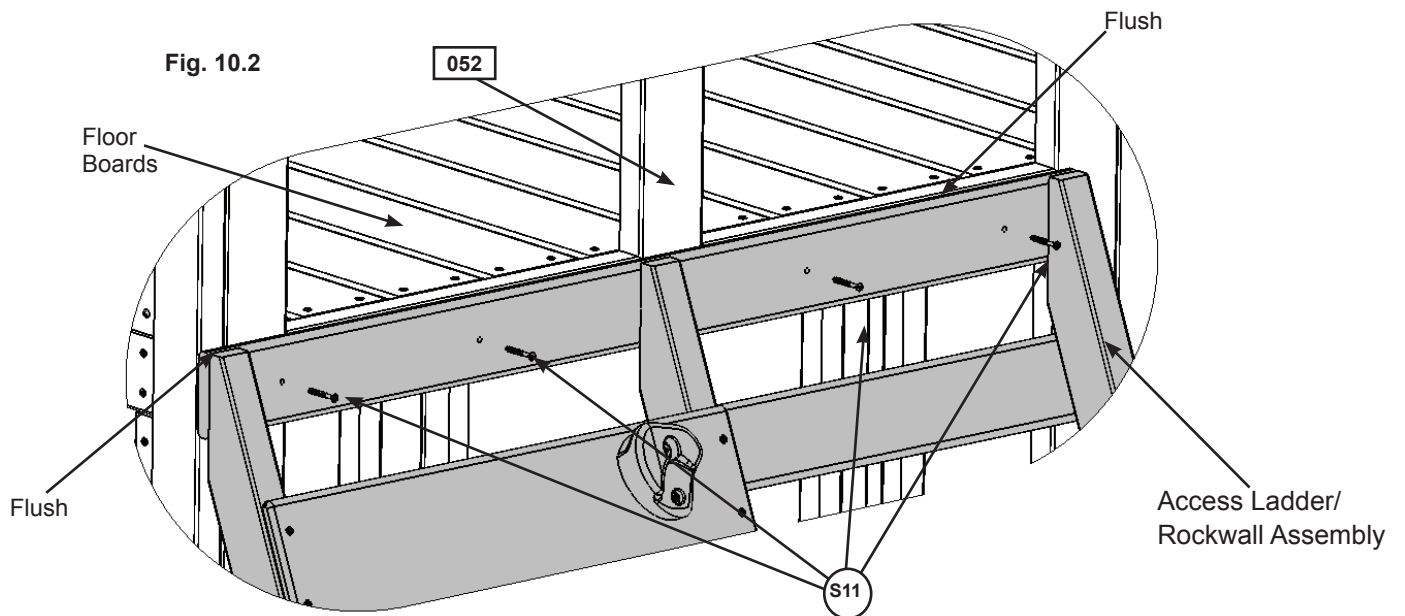



Fig. 10.2



## Hardware

4 x  #8 x 2" Wood Screw



# Step 10: Attach Access Ladder/Rockwall Assembly Part 2

**B:** Place (031) Access Board from Step 3, Part 1 against (020) Left Access and (024) Rock Rail and flush to the top then attach with 4 (S20) #8 x 1-3/8" Wood Screws. (fig. 10.3 and 10.4)

Fig. 10.3

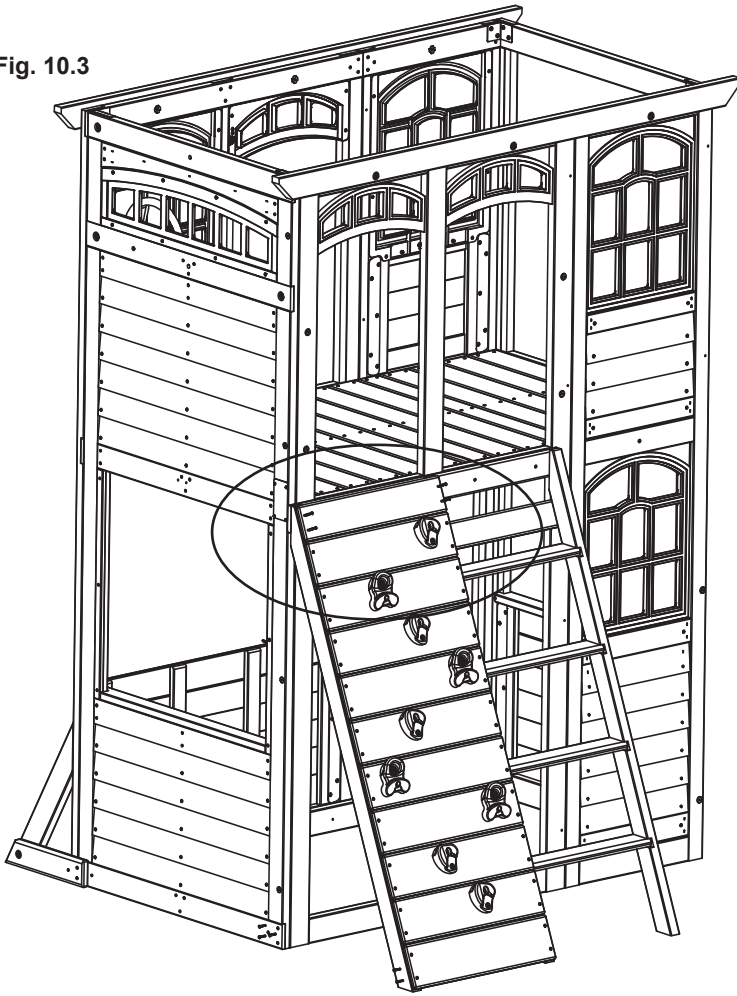
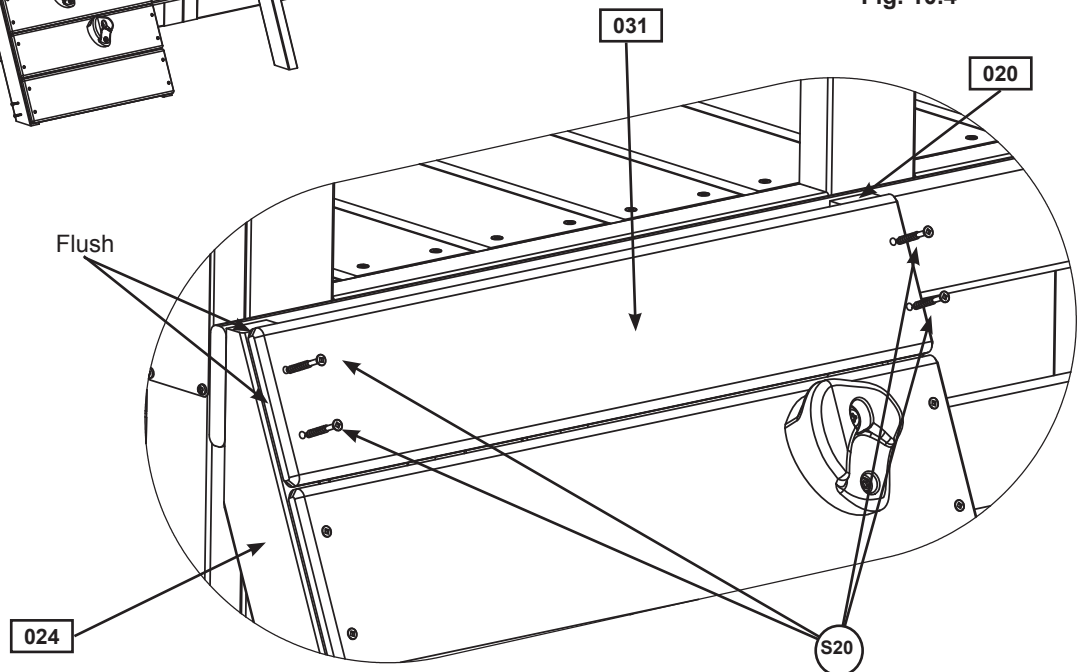

Fig. 10.4



### Hardware

4 x  #8 x 1-3/8" Wood Screw

# Step 10: Attach Access Ladder/Rockwall Assembly Part 3

**C:** Place (100) RW-AL Ground Brace flush to the end and bottom of (024) Rock Rail. Make sure the other end of the board is flush to the bottom of (050) SW Wall Panel then attach to (024) Rock Rail with 2 (S11) #8 x 2" Wood Screws. (fig. 10.5 and 10.6)

**D:** Attach other end of (100) RW-AL Ground Brace to (050) SW Wall Panel with 2 (S11) #8 x 2" Wood Screws and 1 (S4) #8 x 3" Wood Screw. (fig. 10.5 and 10.6)

Fig. 10.5

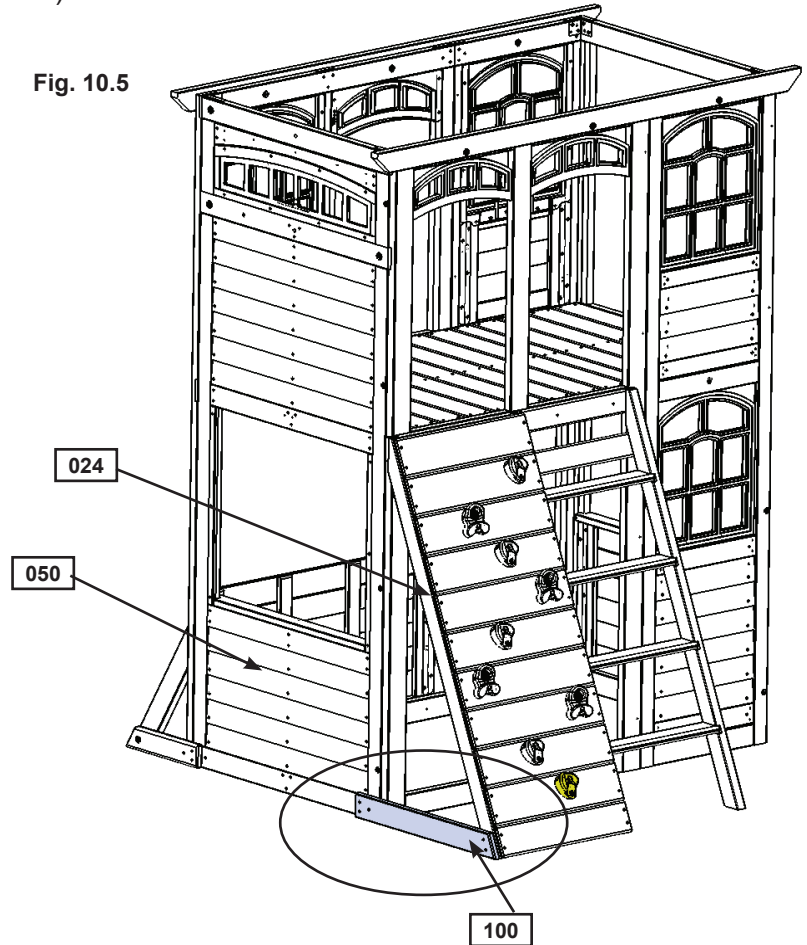
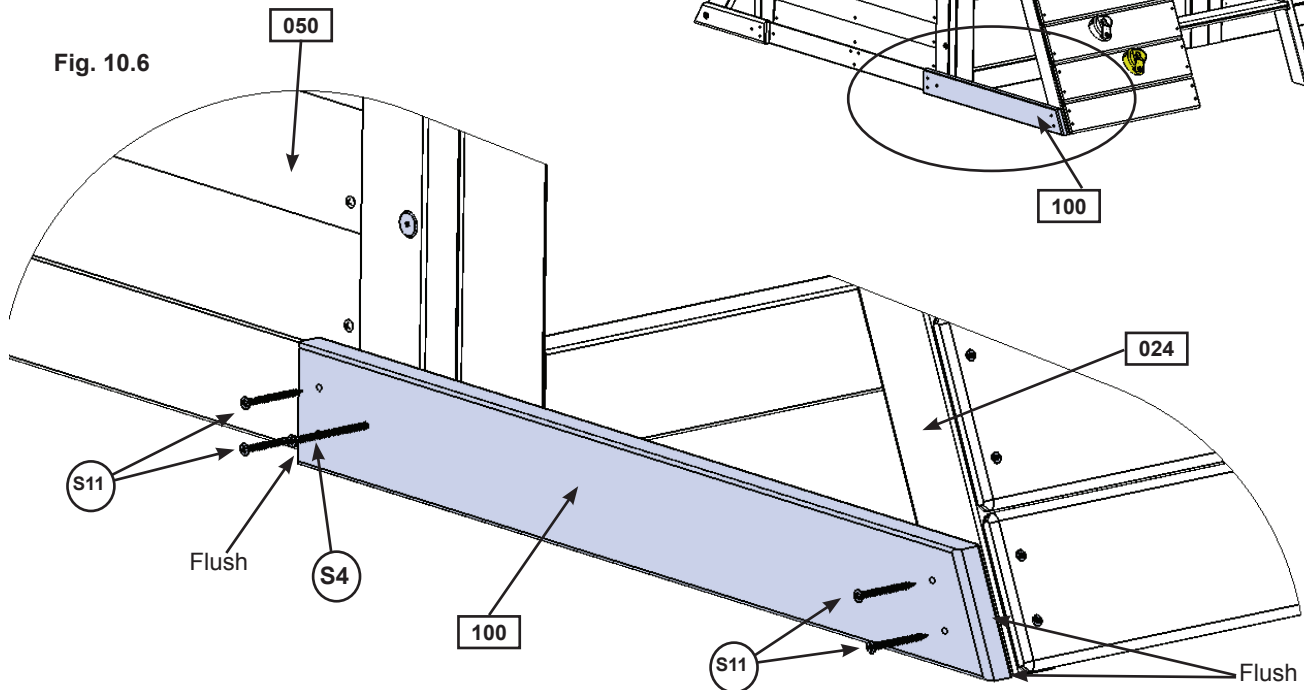

Fig. 10.6



### Wood Parts

1 x 100 RW-AL Ground Brace 5/4 x 4 x 27-3/4"

### Hardware

1 x S4 #8 x 3" Wood Screw

4 x S11 #8 x 2" Wood Screw

# Step 11: Attach Steel Hand Grips to Fort

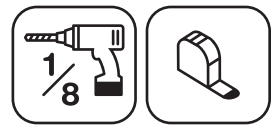

**A:** Measure 6" from the top of (025) RW/AL Support on (052) Back Wall Panel in the 2 places shown below, pre-drill with a 1/8" drill bit then attach 2 Steel Hand Grips with 2 (WL3) 1/4 x 1-3/8" Wafer Lag (with flat washer) per Steel Hand Grip. (fig. 11.1 and 11.2)

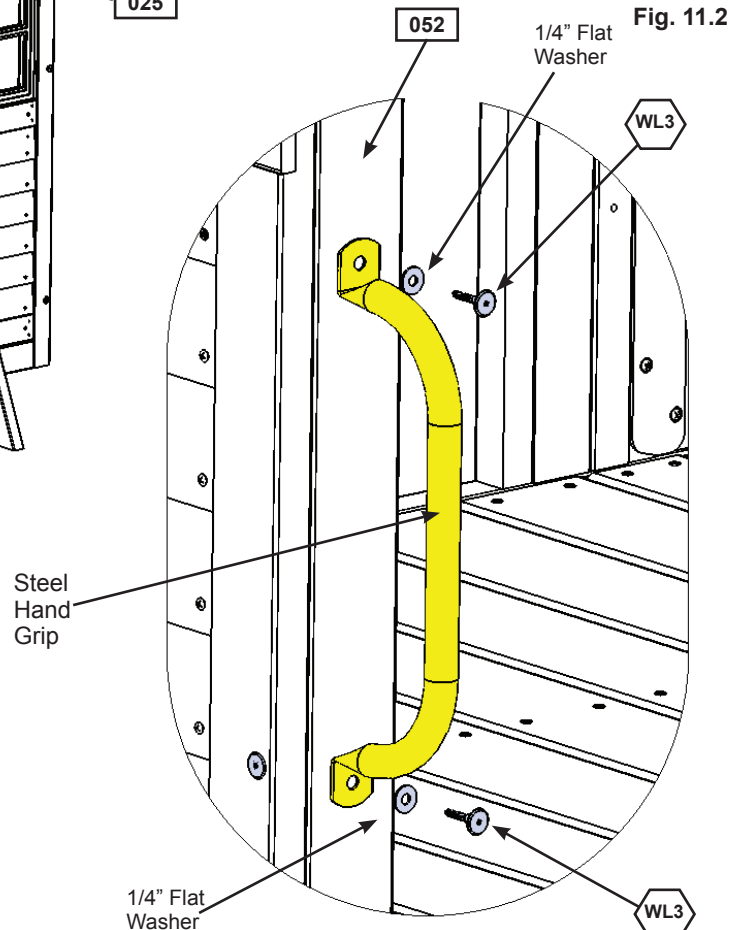
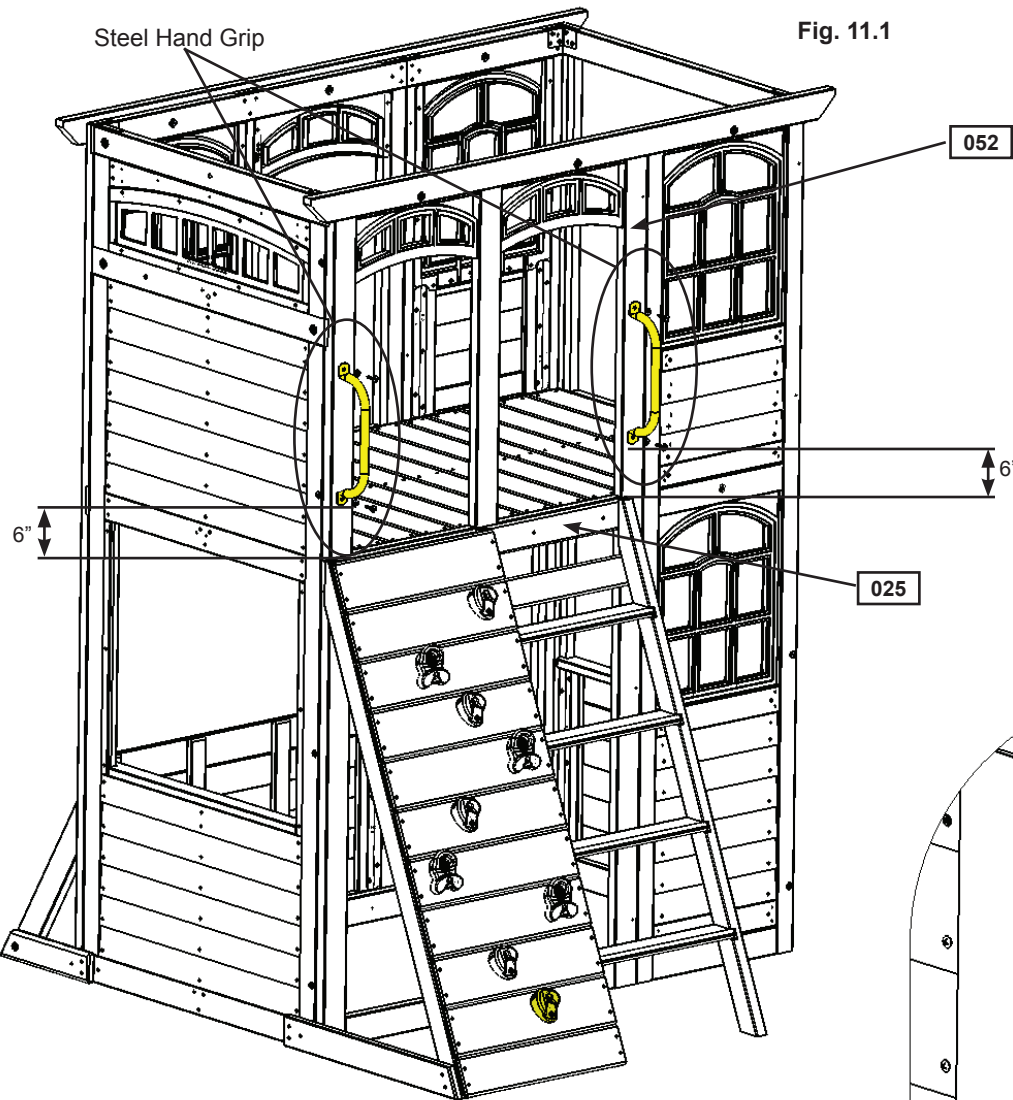

### Hardware

4 x  1/4 x 1-3/8" Wafer Lag  
(1/4" flat washer)

### Other Parts

2 x Steel Hand Grip

# Step 12: Door Panel Assembly Part 1



**A:** On the inside of (120) Door Window Panel measure 15" up from the bottom and attach Catch Plate flush to the edge using 2 (S18) #6 x 1" Wood Screws. (fig. 12.1 and 12.2)

**B:** On the inside of (120) Door Window Panel measure 22" up from the bottom and attach 1 Door Handle using 2 (S13) #6 x 5/8" Pan Screws. (fig. 12.1 and 12.2)

Fig. 12.1

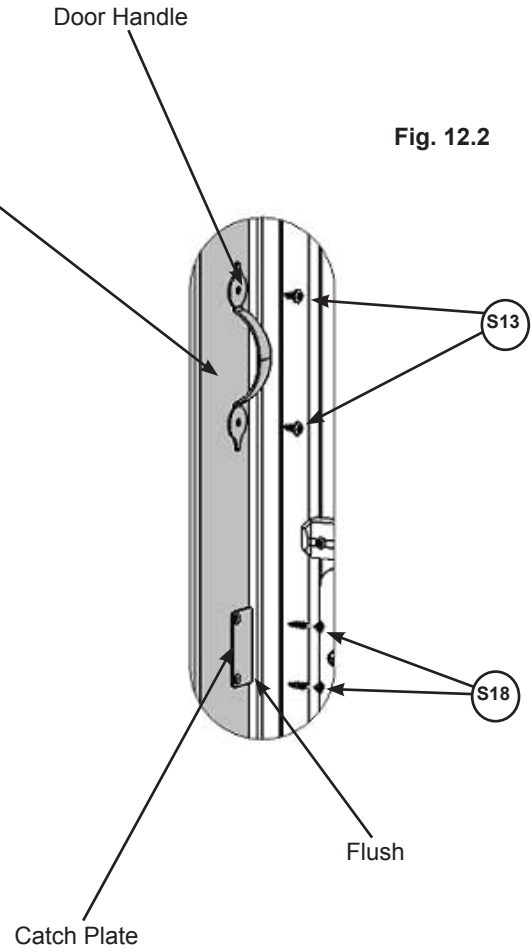
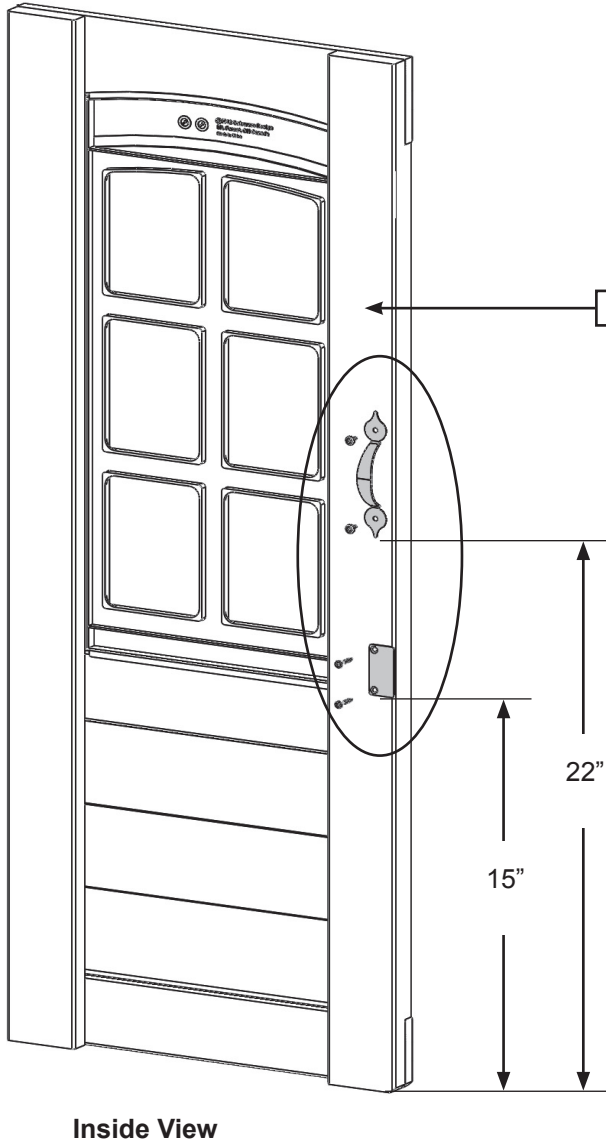

Fig. 12.2

### Wood Parts

1 x 120 Door Window Panel 1-1/4 x 15-3/4 x 42-1/8"

### Hardware

2 x S18 #6 x 1" Wood Screw  
2 x S13 #6 x 5/8" Pan Screw

### Other Parts

1 x Door Handle  
1 x Catch Plate

# Step 12: Door Panel Assembly Part 2

**C:** On the outside of the (120) Door Window Panel attach the second Door Handle at approximately the same place as the one on the inside. Use 2 (S13) #6 x 5/8" Pan Screws. (fig. 12.3)

**D:** Attach 2 Door Hinges on the outside of the (120) Door Window Panel on the opposite side from the Door Handle. Judge spacing based on fig. 12.3. Use 3 (S13) #6 x 5/8" Pan Screws per Hinge.

**Note:** Hinge stops must be tight to (120) Door Window Panel. (fig. 12.4)

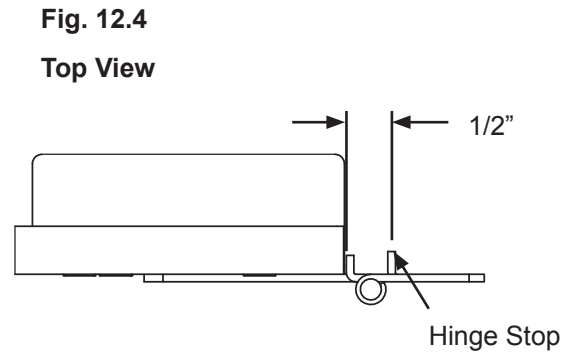
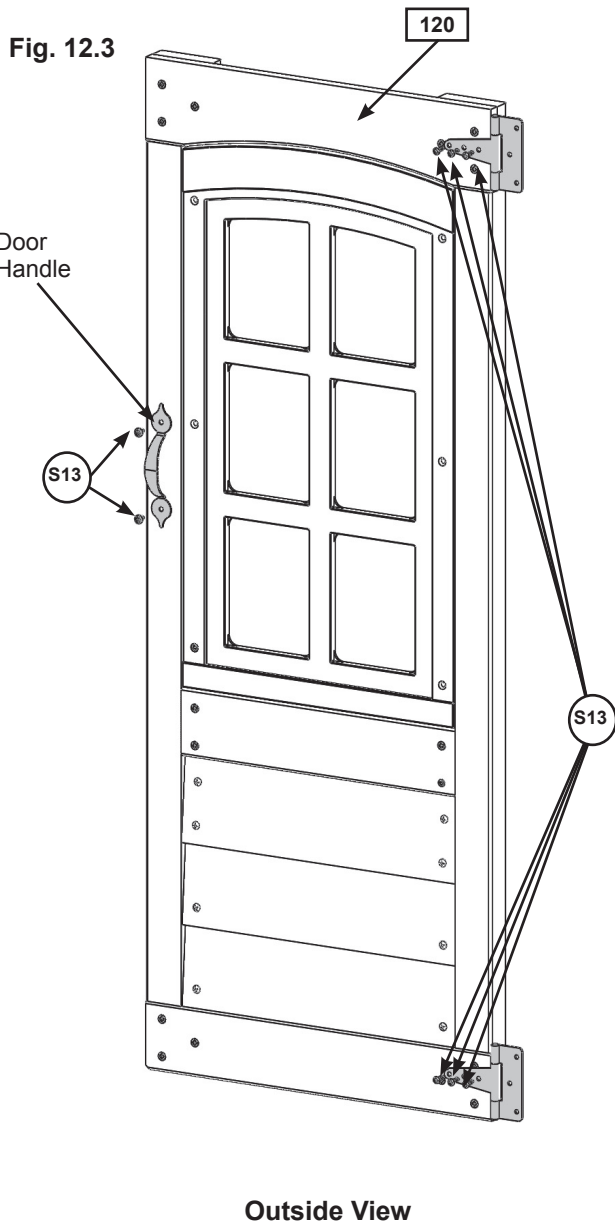

### Hardware

8 x (S13) #6 x 5/8" Pan Screw

### Other Parts

1 x Door Handle  
2 x Door Hinge



# Step 12: Door Panel Assembly Part 3



E: In the opening for the door, measure  $3/4$ " from the top of (042) Narrow Front Panel bottom and maximum  $5/8$ " from right side of the opening which would be the Door Hinge side and attach the remaining side of the hinges to (042) Narrow Front Panel using 3 (S13) #6 x  $5/8$ " Pan Screws per hinge. (fig. 12.5 and 12.6)

Fig. 12.5

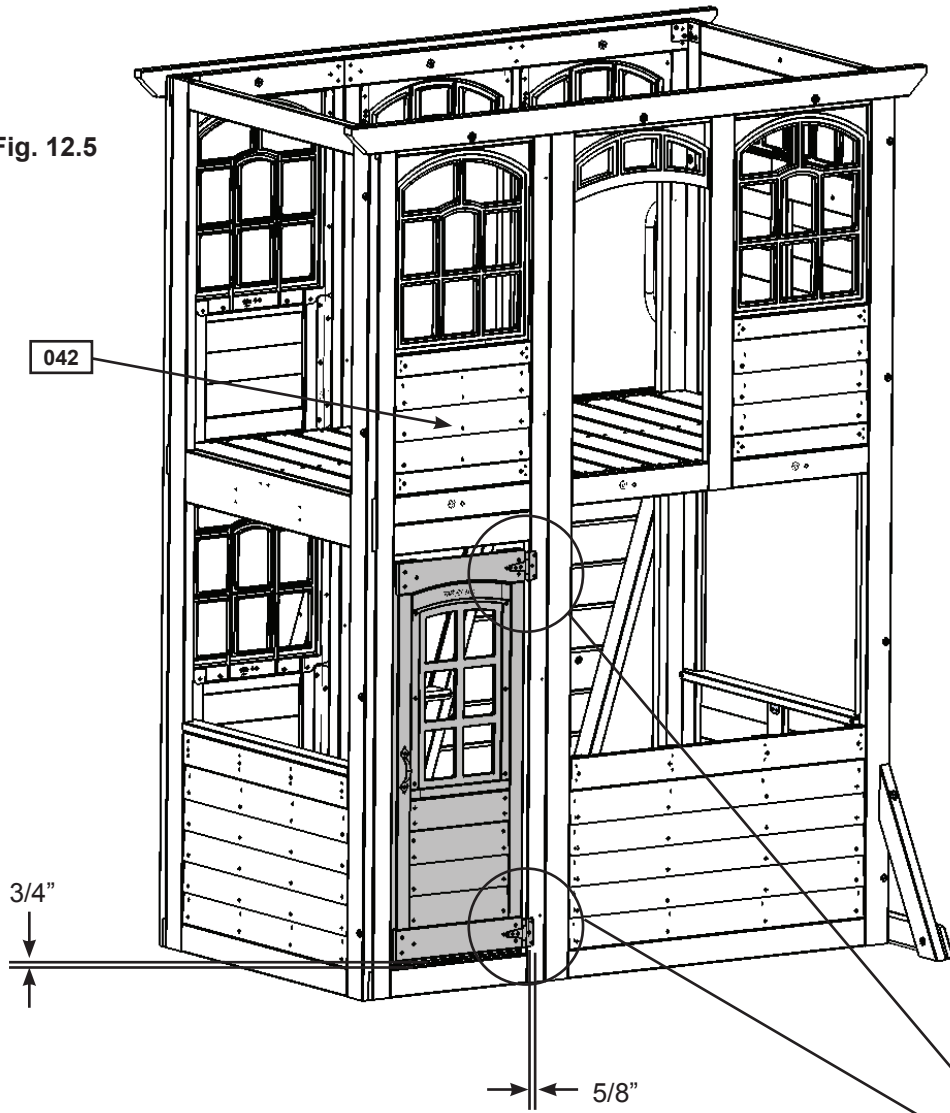
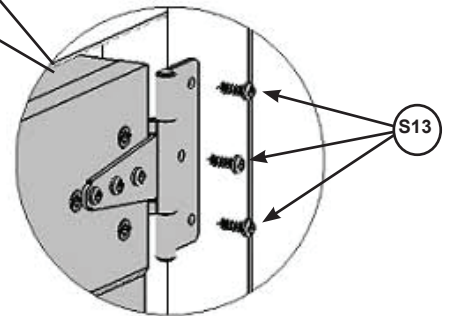

Fig. 12.6



### Hardware

6 x (S13) #6 x  $5/8$ " Pan Screw

# Step 12: Door Panel Assembly Part 4



**F:** In the notched out opening of (121) Door Stop attach the Magnetic Catch using 2 (S18) #6 x 1" Wood Screws. (fig. 12.7) **Important: Use a hand held screw driver and DO NOT over tighten.**

**G:** On the inside of the assembly, attach (121) Door Stop to (042) Narrow Front Panel with 3 (S11) #8 x 2" Wood Screws, making sure (121) Door Stop overhangs (042) Narrow Front Panel by 1-1/4" and is in position to receive the Catch Plate. (fig. 12.8 and 12.9).

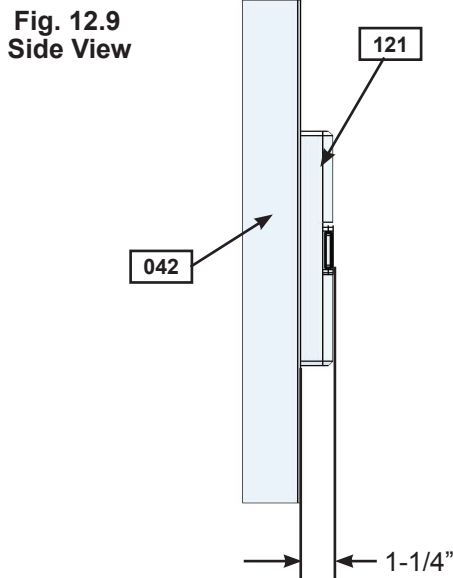
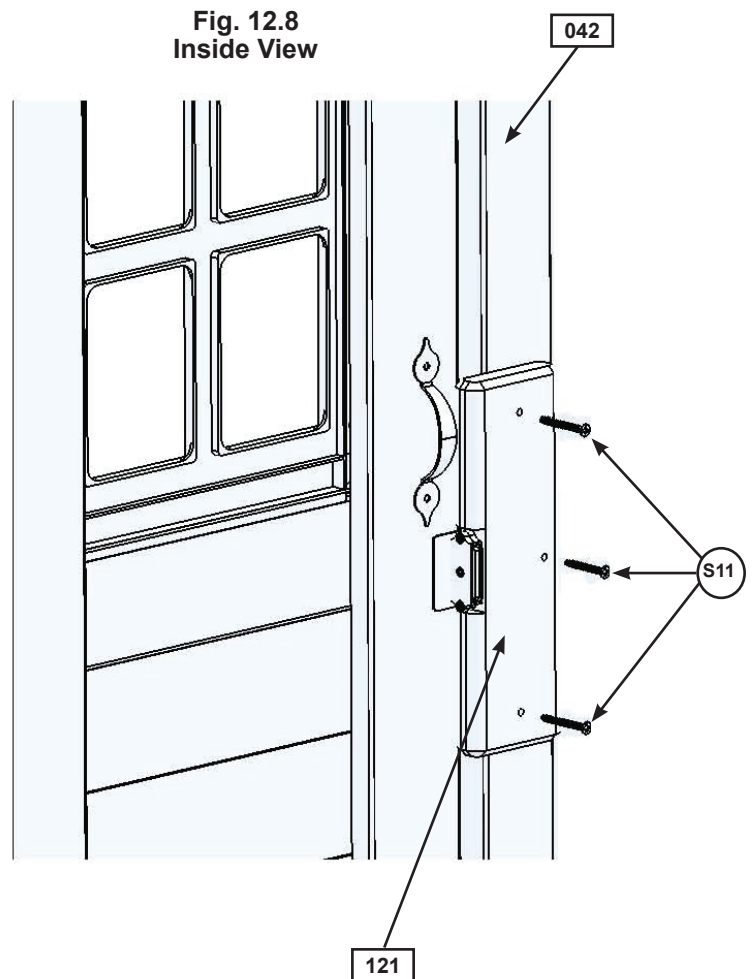
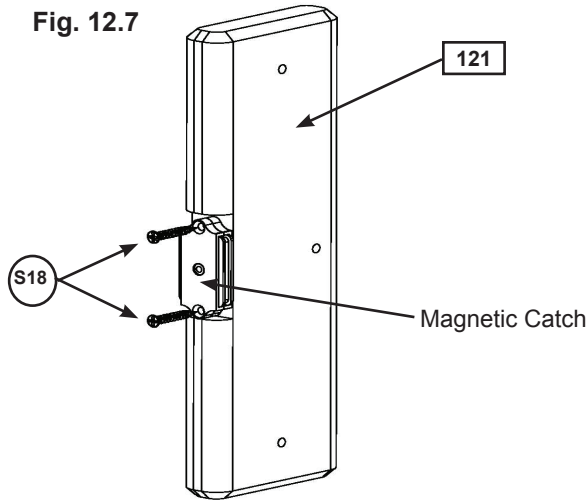

### Wood Parts

1 x 121 Door Stop 5/4 x 3 x 10"

### Hardware

2 x S18 #6 x 1" Wood Screw

3 x S11 #8 x 2" Wood Screw

### Other Parts

1 x Magnetic Catch

# Step 13: Front Wall Assembly Part 1

**A:** Place (130) Table Support flush to the notched out ends of (131) Table Top and attach with 4 (S7) #12 x 2" Pan Screws as shown in fig. 13.1.

**B:** Place Table Top Assembly tight in the opening of (051) Front Wall Panel and attach (130) Table Support to (051) Front Wall Panel with 2 (S3) #8 x 2-1/2" Wood Screws. (fig. 13.2 and 13.3)

Fig. 13.1

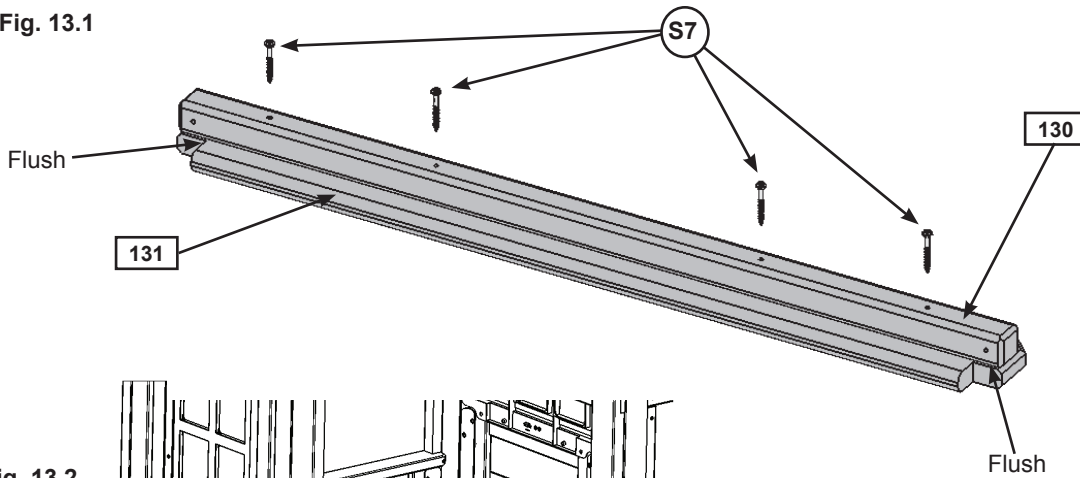

Fig. 13.2

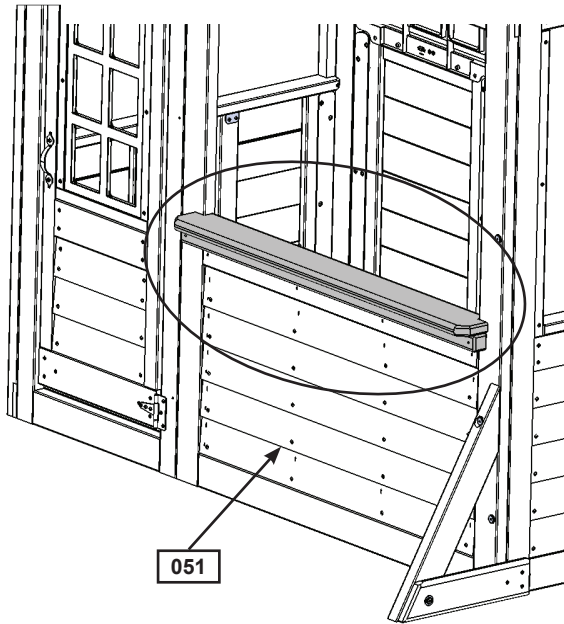
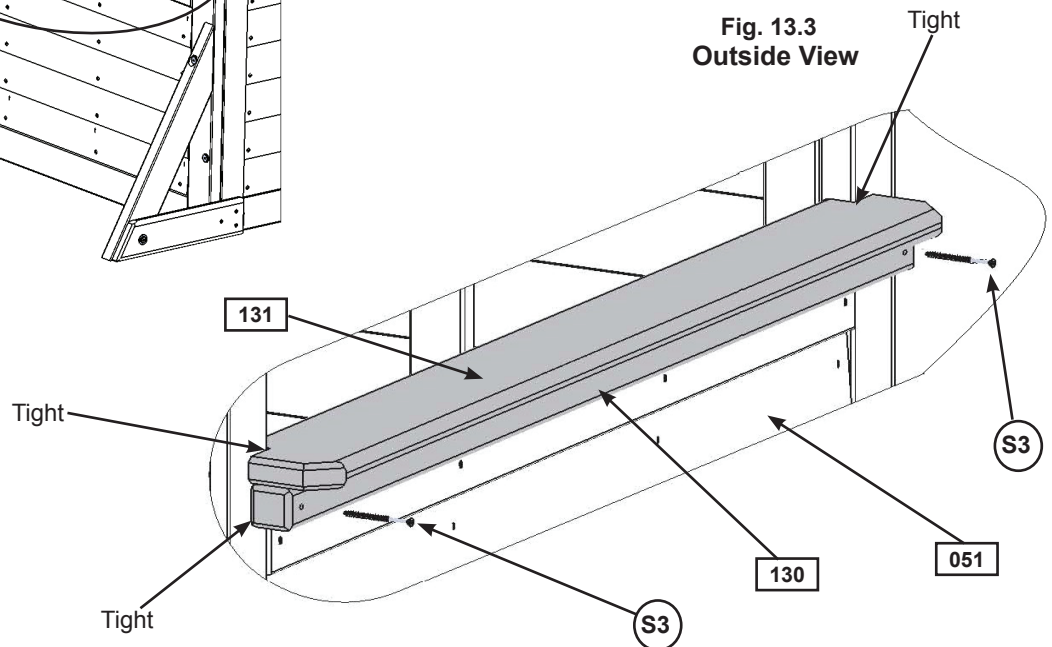

Fig. 13.3  
Outside View



## Wood Parts

- 1 x 130 Table Support 2 x 2 x 39-5/8"
- 1 x 131 Table Top 5/4 x 5 x 39-5/8"

## Hardware

- 4 x S7 #12 x 2" Pan Screw
- 2 x S3 #8 x 2-1/2" Wood Screw

# Step 13: Front Wall Assembly Part 2

**C:** Place (132) Chalkwall Block tight to the top and left hand side of the opening in (051) Front Wall Panel then place the Flat Panel Bracket against (132) Chalkwall Block and (051) Front Wall Panel. Attach Flat Panel Bracket to (051) Front Wall Panel first then to (132) Chalkwall Block with 4 (S8) #12 x 3/4" Pan Screws. (fig. 13.4 and 13.5)

Fig. 13.4

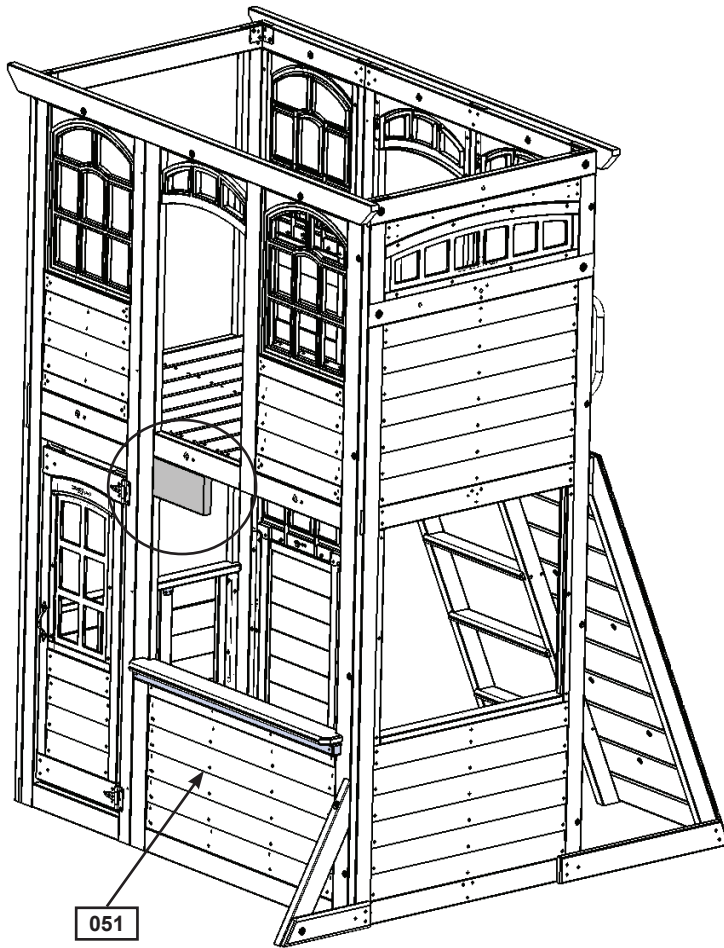
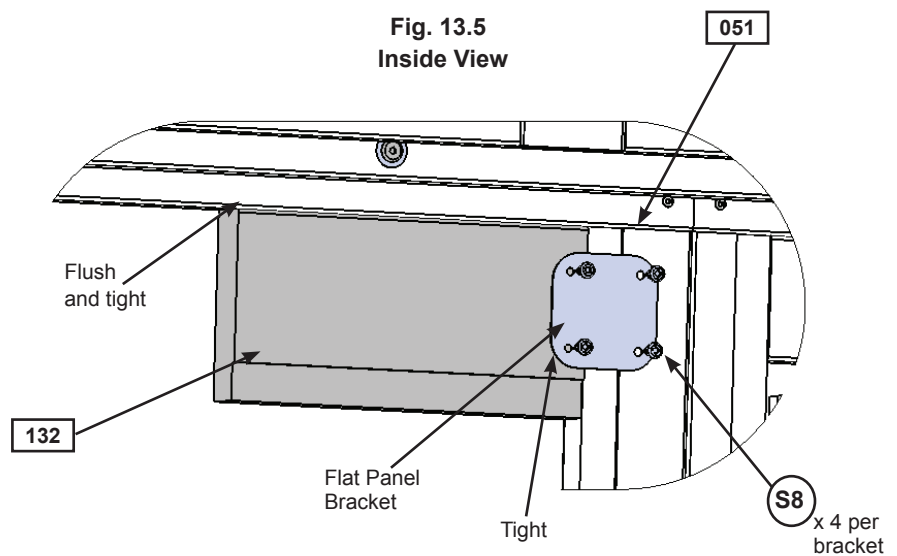

Fig. 13.5  
Inside View



### Wood Parts

1 x 132 Chalkwall Block 1-1/4 x 5 x 10"

### Hardware

4 x S8 #12 x 3/4" Pan Screw

### Other Parts

1 x Flat Panel Bracket

# Step 13: Front Wall Assembly Part 3

**D:** From inside the assembly place Sky Chalk Wall tight to (132) Chalkwall Block and (131) Table Top then attach with 4 (S10) #8 x 1" Pan Screws from the inside and 1 (S10) #8 x 1" Pan Screw from the outside to the left side of the (051) Front Wall Panel. (fig. 13.6, 13.7 and 13.8)

Fig. 13.6

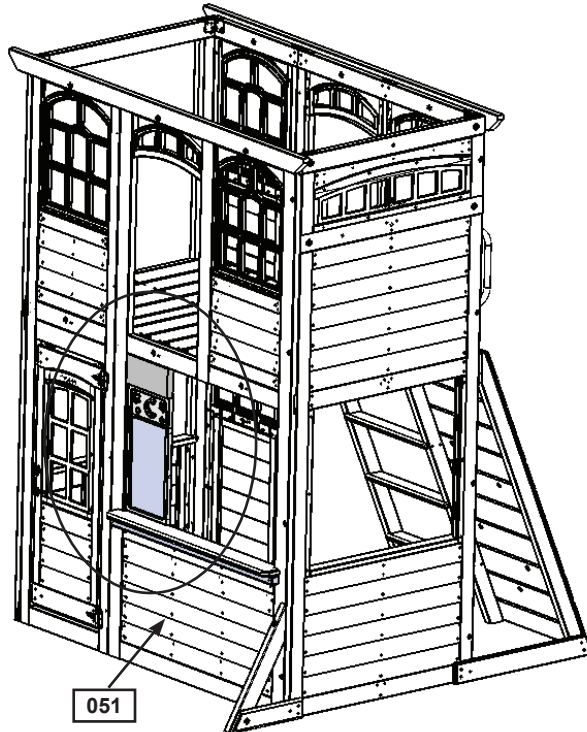

Fig. 13.7  
Inside View

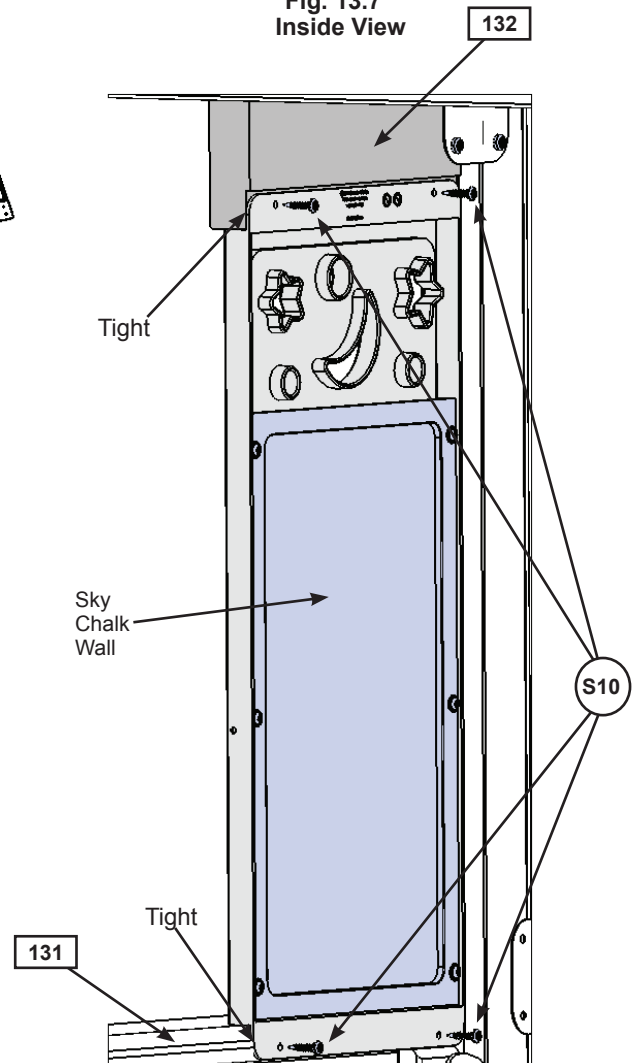
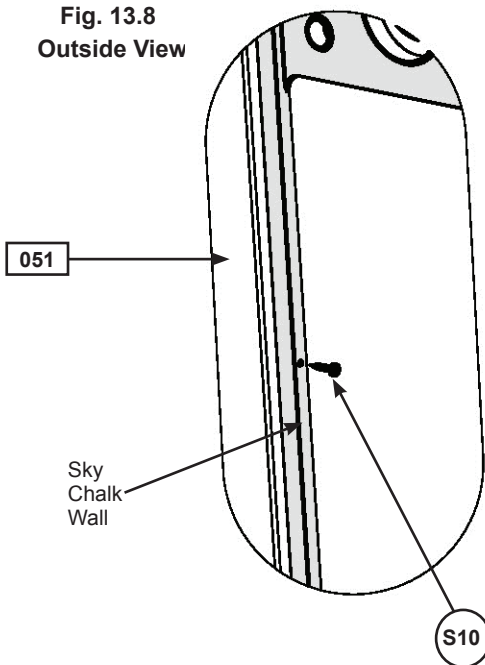

Fig. 13.8  
Outside View



### Hardware

5 x (S10) #8 x 1" Pan Screw

### Other Parts

1 x Sky Chalk Wall



# Step 13: Front Wall Assembly Part 4

E: From inside the assembly place (133) Chalkwall Side tight to (051) Front Wall Panel, (131) Table Top and (132) Chalkwall Block. Attach to (132) Chalkwall Block first from the side with 1 (S3) #8 x 2-1/2" Wood Screw then from the inside to (051) Front Wall Panel with 1 (S20) #8 x 1-3/8" Wood Screw and (131) Table Top with 1 (S11) #8 x 2" Wood Screw. From the outside attach Sky Chalkwall to (133) Chalkwall Side with 1 (S10) #8 x 1" Pan Screw. (fig. 13.9, 13.10 and 13.11)

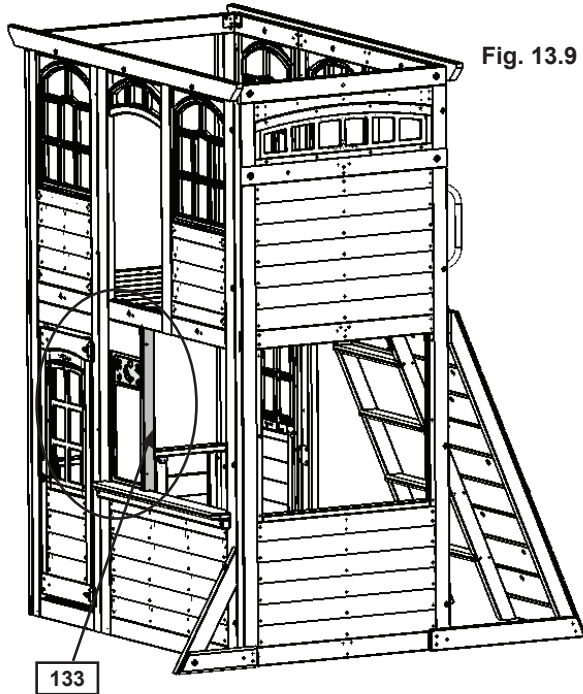

Fig. 13.9

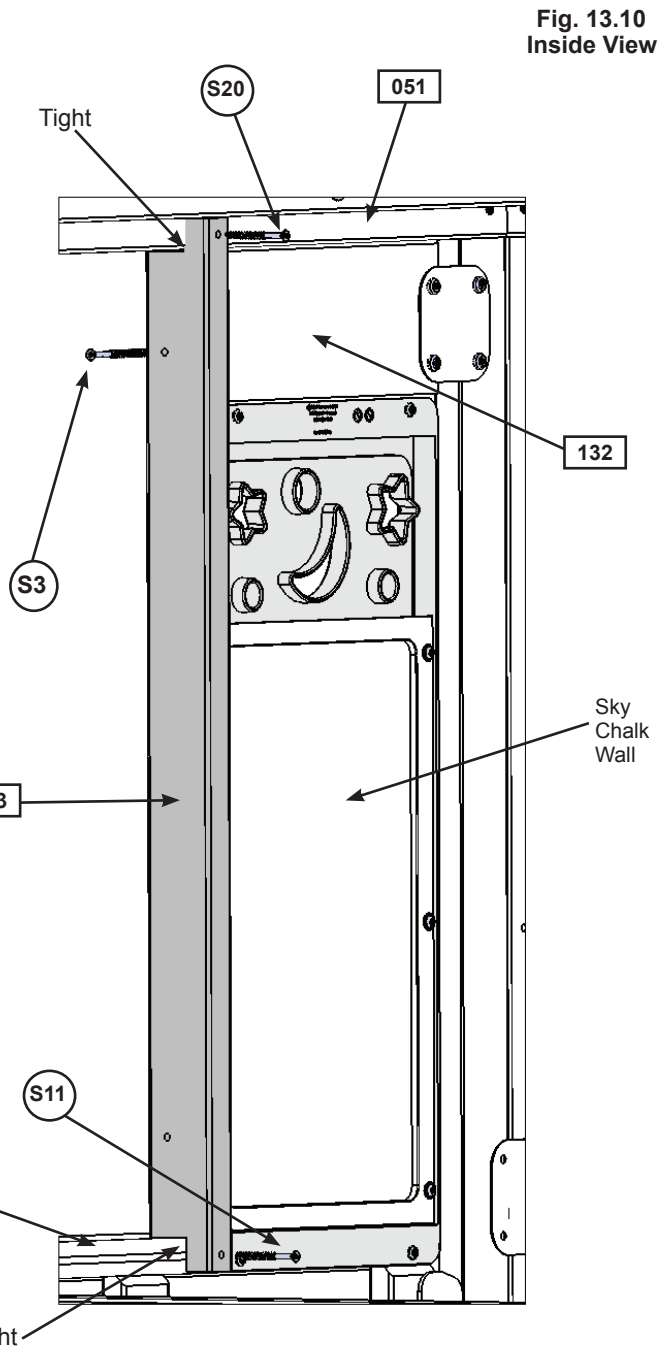
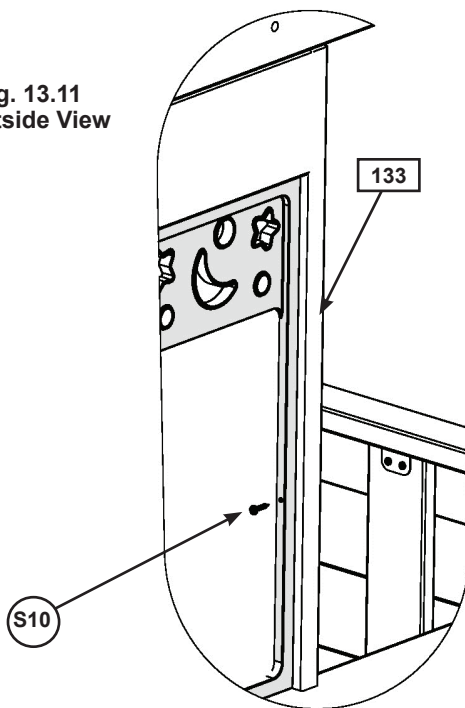

Fig. 13.10  
Inside View

Fig. 13.11  
Outside View



### Wood Parts

1 x **133** Chalkwall Side 1 x 2 x 27-7/16"

### Hardware

- 1 x **(S11)** #8 x 2" Wood Screw
- 1 x **(S3)** #8 x 2-1/2" Wood Screw
- 1 x **(S10)** #8 x 1" Pan Screw
- 1 x **(S20)** #8 x 1-3/8" Wood Screw

# Step 14: Swing Beam Assembly Part 1

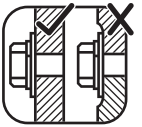

**A:** Attach 6 Heavy Duty Swing Hangers to (140) Engineered SW Beam using 2 (G13) 5/16 x 6-1/8" Hex Bolt (with 2 flat washers, plastic formed washer and lock nut) per swing hanger, as shown in fig. 14.1 and 14.2.

**B:** Attach 1 Spring Loaded Quick Link to each Heavy Duty Swing Hanger. (fig. 14.3)

**C:** Install 1 (WB7) 5/16 x 3" Wafer Bolt (with flat washer and t-nut) in the middle bolt hole, from the bottom up, in (140) Engineered SW Beam as shown in fig. 14.1 and 14.4. **IT IS IMPORTANT THAT THIS BOLT IS ATTACHED. IT WILL MINIMIZE CHECKING OF WOOD.**

**D:** Attach KidKraft Logo Plaque to centre of (140) Engineered SW Beam (over top of t-nut) using 4 (S18) #6 x 1" Wood Screws. (fig. 14.5)

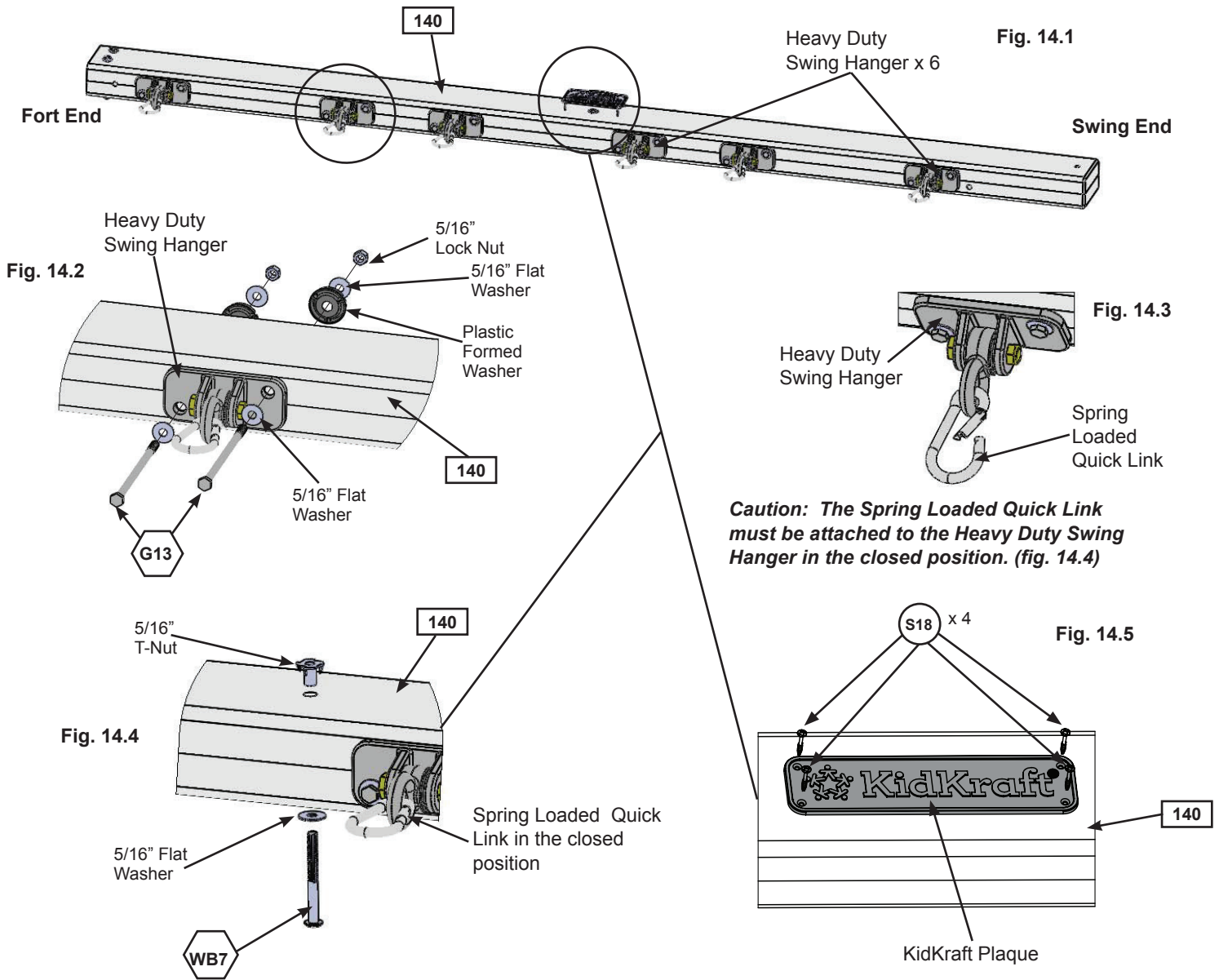

### Wood Parts

1 x (140) Engineered SW Beam 4 x 6 x 92"

### Hardware

12 x (G13) 5/16 x 6-1/8" Hex Bolt (5/16" flat washer x 2, 5/16" lock nut & plastic formed washer)  
 1 x (WB7) 5/16 x 3" Wafer Bolt (5/16" flat washer, 5/16" t-nut)  
 4 x (S18) #6 x 1" Wood Screw

### Other Parts

6 x Heavy Duty Swing Hangers  
 6 x Spring Loaded Quick Link  
 1 x KidKraft Logo Plaque

# Step 14: Swing Beam Assembly Part 2

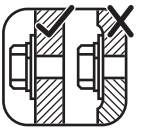

**E:** On the Fort End of (140) Engineered SW Beam attach 2 Heavy Flat Brackets with 2 (G21) 5/16 x 3-3/4" Hex Bolts (with 2 flat washers and 1 lock nut). (fig. 14.6 and 14.7)

**F:** Place (141) SW Mount in between both Heavy Flat Brackets and place 1 Heavy L-Bracket against (140) Engineered SW Beam and (141) SW Mount. Attach with 1 (G17) 3/8 x 6" Hex Bolt (with 2 flat washers, plastic formed washer and lock nut). (fig. 14.8)

**G:** Attach (141) SW Mount to Heavy Flat Brackets with 2 (G21) 5/16 x 3-3/4" Hex Bolts (with 2 flat washers and 1 lock nut). (fig. 14.9)

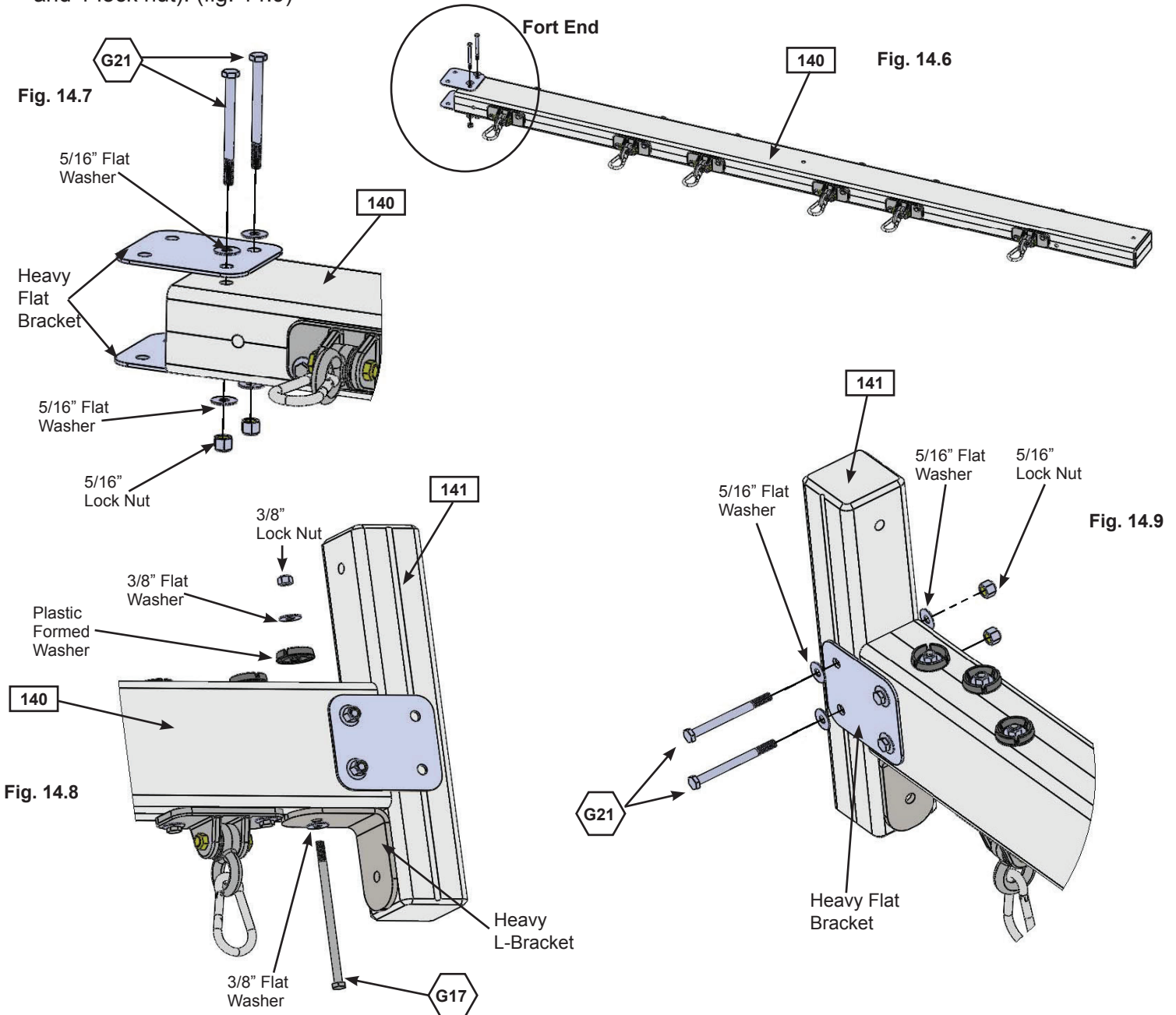

### Wood Parts

1 x 141 SW Mount 4 x 4 x 16"

### Hardware

4 x G21 5/16 x 3-3/4" Hex Bolt  
(5/16" flat washer x 2, 5/16" lock nut)

1 x G17 3/8 x 6" Hex Bolt  
(3/8" flat washer x 2, plastic formed washer & 3/8" lock nut)

### Other Parts

2 x Heavy Flat Bracket  
1 x Heavy L-Bracket

# Step 15: Swing Post Assembly Part 1

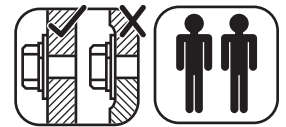

**Note: Keep all bolts from Step 15 series loose until start of Step 17**

**A:** Place (150) SW Block Angle on top of (151) Block SW and attach 2 Heavy L-Brackets on top of (150) SW Block Angle feeding 2 (G17) 3/8 x 6" Hex Bolts (with 2 flat washers, plastic formed washer and lock nut) through both boards as shown in fig. 15.1 and 15.2.

**B:** Attach 3 (WB7) 5/16 x 3" Wafer Bolts (with flat washer and t-nut) to all three holes in each (152) SW Post as shown in fig. 15.3. **IMPORTANT! MAKE SURE ALL 6 BOLTS ARE ATTACHED TO MINIMIZE CHECKING OF WOOD.**

**C:** Place (150) SW Block Angle and (151) Block SW assembly in between 2 (152) SW Post (Heavy L-Brackets towards the outside). Place 1 Heavy C-Bracket on the top (152) SW Post and attach with (G26) 3/8 x 9-1/4" Hex Bolt (with 2 flat washers and 1 lock nut), as shown in fig. 15.4.

Fig. 15.1  
Bottom View

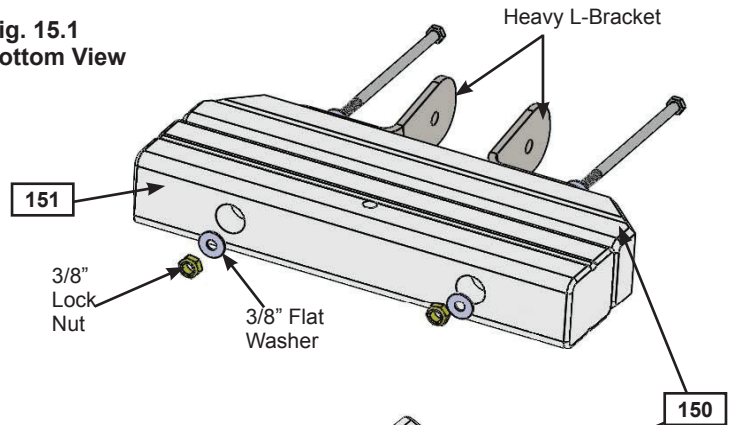

Fig. 15.2  
Top View

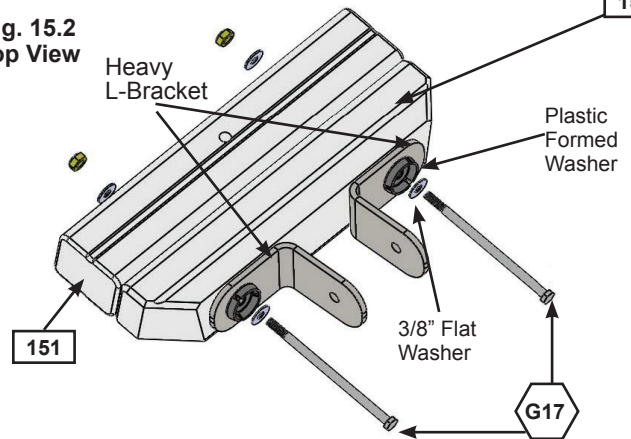

Fig. 15.3

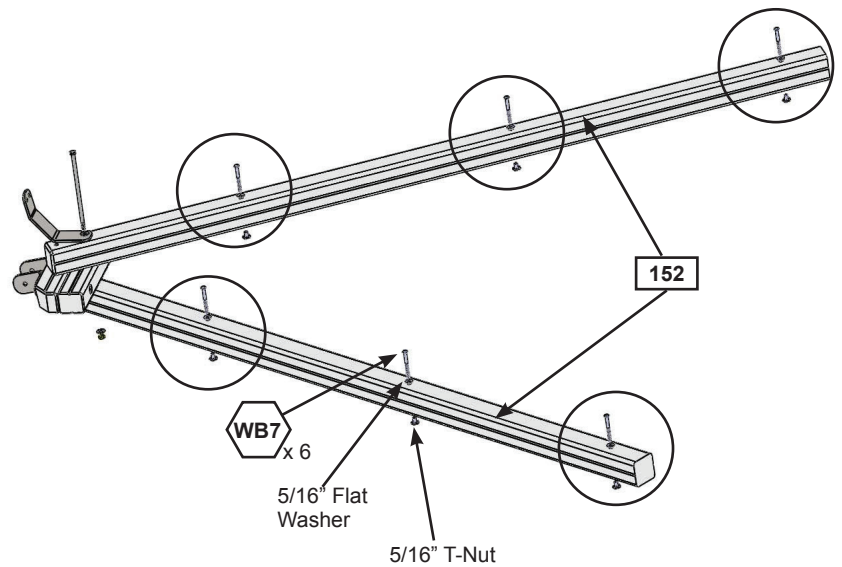
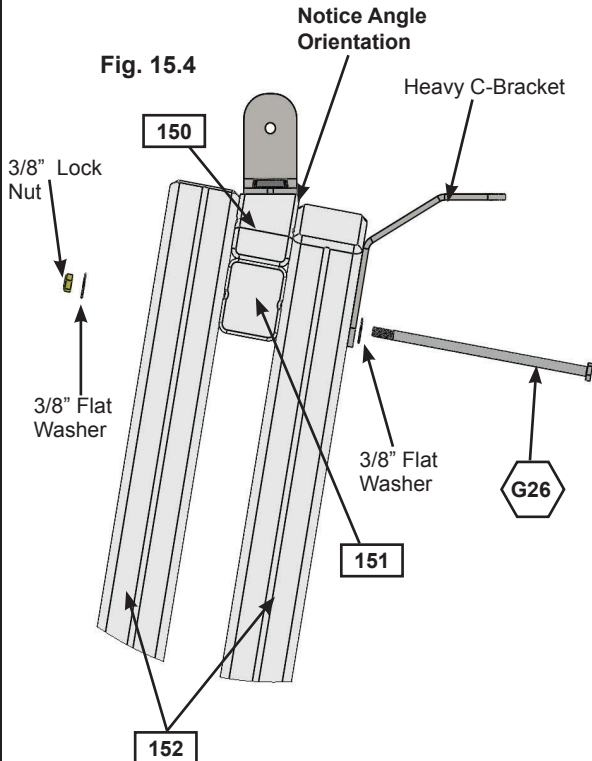

Fig. 15.4



### Wood Parts

- 1 x 150 SW Block Angle 2-1/2 x 3 x 15"
- 1 x 151 Block SW 2-1/2 x 3 x 15"
- 2 x 152 SW Post 4 x 4 x 92"

### Hardware

- 2 x G17 3/8 x 6" Hex Bolt (3/8" flat washer x 2, plastic formed washer & 3/8" lock nut)
- 1 x G26 3/8 x 9-1/4" Hex Bolt (3/8" flat washer x 2 & 3/8" lock nut)
- 6 x WB7 5/16 x 3" Wafer Bolt (5/16" flat washer & 5/16" t-nut)

### Other Parts

- 2 x Heavy L-Bracket
- 1 x Heavy C-Bracket





# Step 15: Swing Post Assembly Part 2

**D:** Place Swing End of (140) Engineered SW Beam in between Heavy L-Brackets assembled in Step A making sure holes are lined up then attach Swing Post Assembly to Swing Beam Assembly using 1 (G20) 3/8 x 4" Hex Bolt (with 2 flat washers and lock nut) through Heavy L-Bracket. (fig. 15.5)

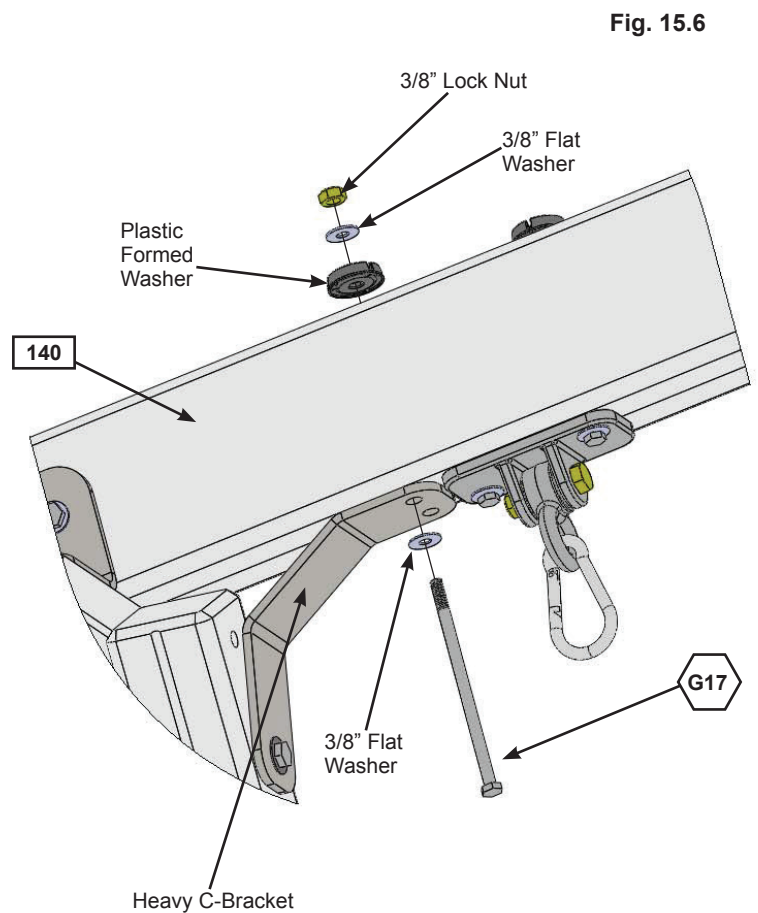
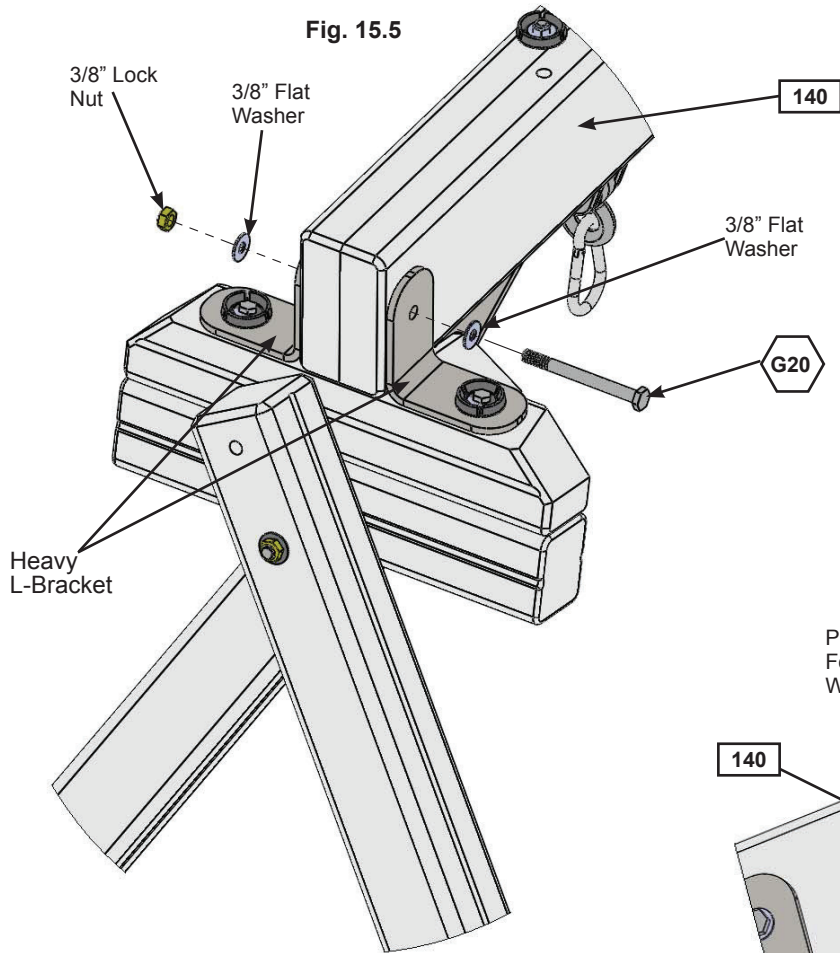
**E:** Attach (140) Engineered SW Beam to Heavy C-Bracket with 1 (G17) 3/8 x 6" Hex Bolt (with 2 flat washers, plastic formed washer and lock nut). (fig. 15.6)



### Hardware

- 1 x  3/8 x 6" Hex Bolt  
(3/8" flat washer x 2, plastic formed washer & 3/8" lock nut)
- 1 x  3/8 x 4" Hex Bolt  
(3/8" flat washer x 2 & 3/8" lock nut)



# Step 15: Swing Post Assembly Part 3

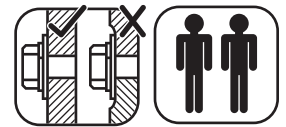

F: Place (141) SW Mount flush to the top of (050) SW Wall Panel. Attach with 1 (G5) 5/16 x 4-1/2" Hex Bolt (with lock washer, flat washer and t-nut) in the bottom hole from outside the assembly and 1 (G5) 5/16 x 4-1/2" Hex Bolt (with 2 x flat washer and 1 lock nut) in the top hole from inside the assembly. (fig. 15.7 and 15.8)

Fig. 15.7

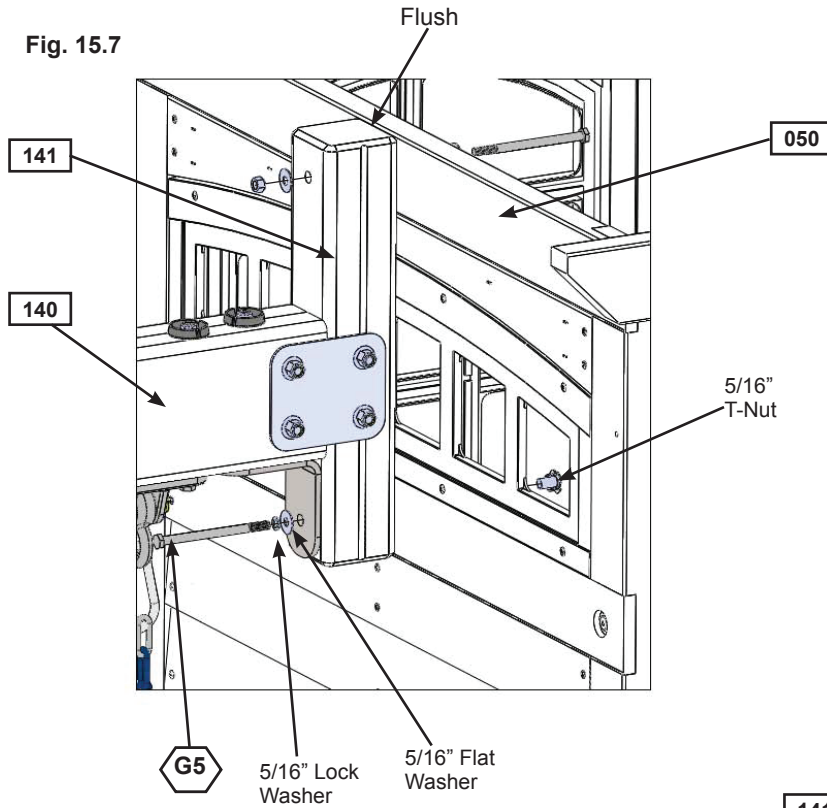
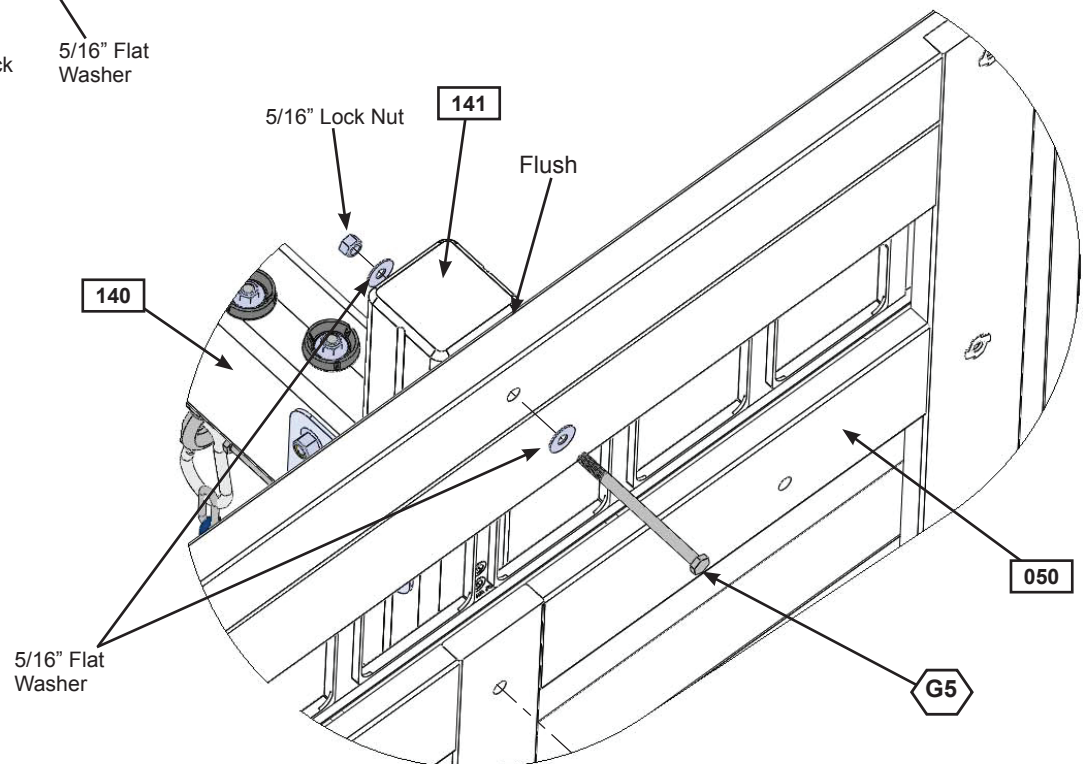

Fig. 15.8



### Hardware

- 2 x G5 5/16 x 4-1/2" Hex Bolt  
 (1 - 5/16" lock washer, 5/16" flat washer, 5/16" t-nut)  
 (1 - 5/16" flat washer x 2, 5/16" lock nut)

# Step 16: Attach Cross Support

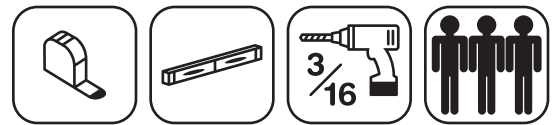

**Pre-drill all holes using a 3/16" drill bit before installing the lag screws.**

**A:** To adjust for uneven ground, raise or lower the (160) Support Cross on the (152) SW Post. Make sure the Support Cross is level prior to attaching with the lag screws. (fig. 16.1 and 16.2)

**B:** Place (160) Support Cross between (152) SW Posts at the previously determined spot and fasten with 1 (LS9) 5/16 x 4-3/4" Lag Screw (with flat washer) per side. (fig. 16.2 and 16.3) **Notice one side is fastened on the outside and one on the inside. It is important that each side is positioned exactly the same as the diagram. (fig. 16.3) Tighten the lag screw when you are sure (160) Support Cross is level.**

**C:** Attach 1 (WB8) 5/16 x 2-3/8" Wafer Bolt (with flat washer and t-nut) to (160) Support Cross through the middle hole. (fig. 16.2 and 16.3) **IMPORTANT! MAKE SURE THE BOLT IS ATTACHED TO MINIMIZE CHECKING OF WOOD.**

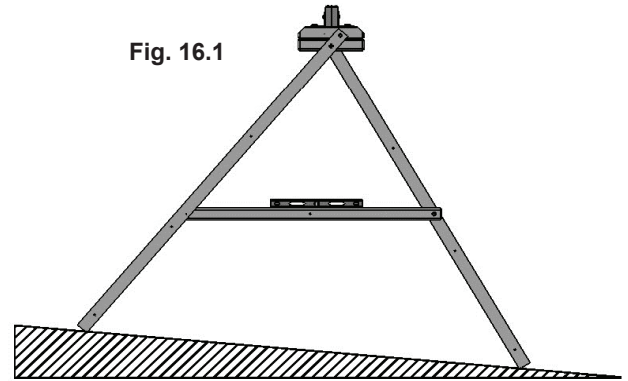

Fig. 16.1

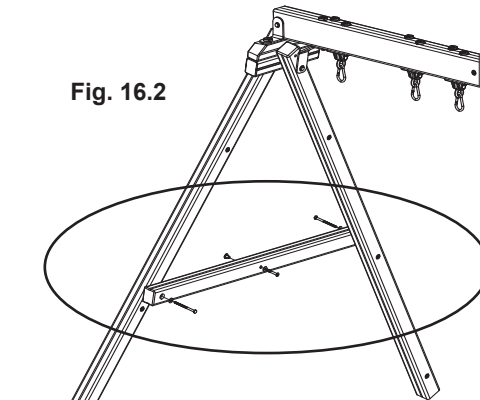

Fig. 16.2

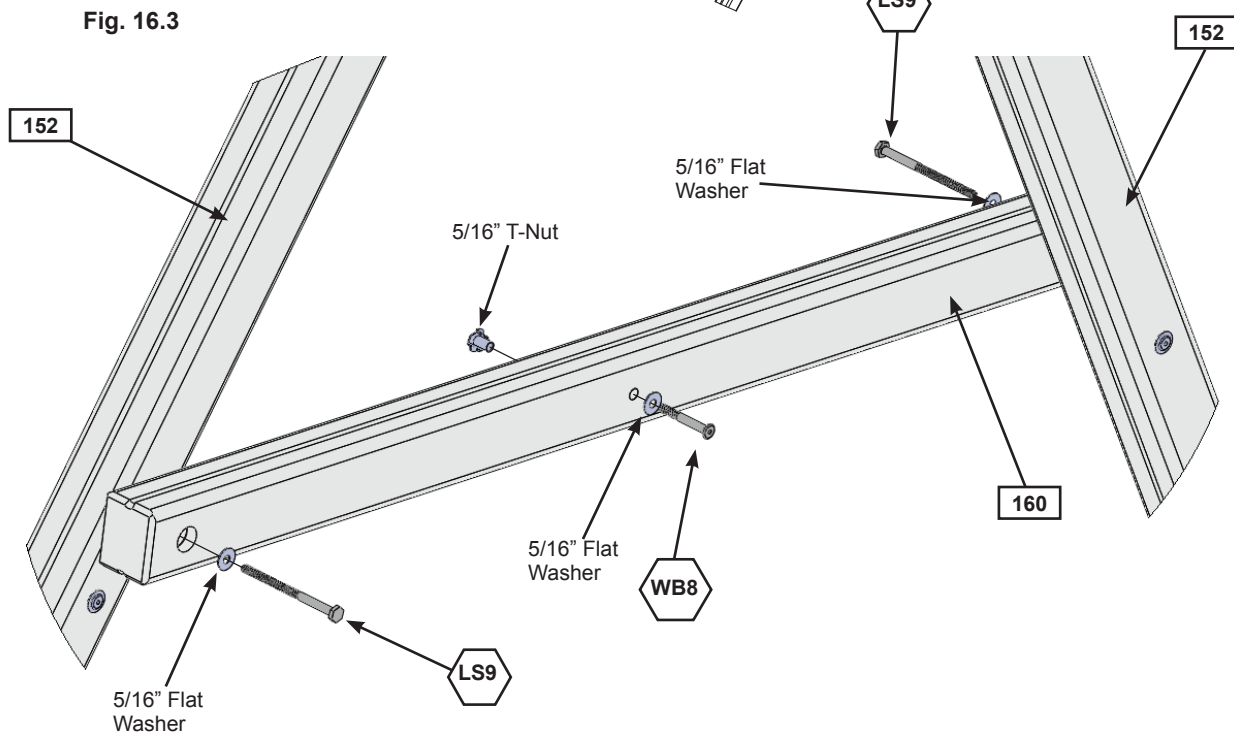

Fig. 16.3

### Wood Parts

1 x 160 Support Cross 2-1/2 x 3 x 51"

### Hardware

- 2 x LS9 5/16 x 4-3/4" Lag Screw (5/16" flat washer)
- 1 x WB8 5/16 x 2-3/8" Wafer Bolt (5/16" flat washer, 5/16" t-nut)

# Step 17: Final Swing Post Assembly

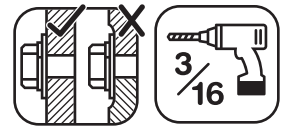

*Pre-drill all holes using a 3/16" drill bit before installing the lag screws.*

*Note: Tighten all bolts from Step 15 series before installing lag screws.*

**A:** Attach 1 (LS9) 5/16 x 4-3/4" Lag Screw (with flat washer) into each (152) SW Post, as shown in fig. 17.1.

**B:** Attach 1 (LS9) 5/16 x 4-3/4" Lag Screw (with flat washer) into remaining hole of the Heavy C-Bracket into (140) Engineered SW Beam. (fig. 17.1)

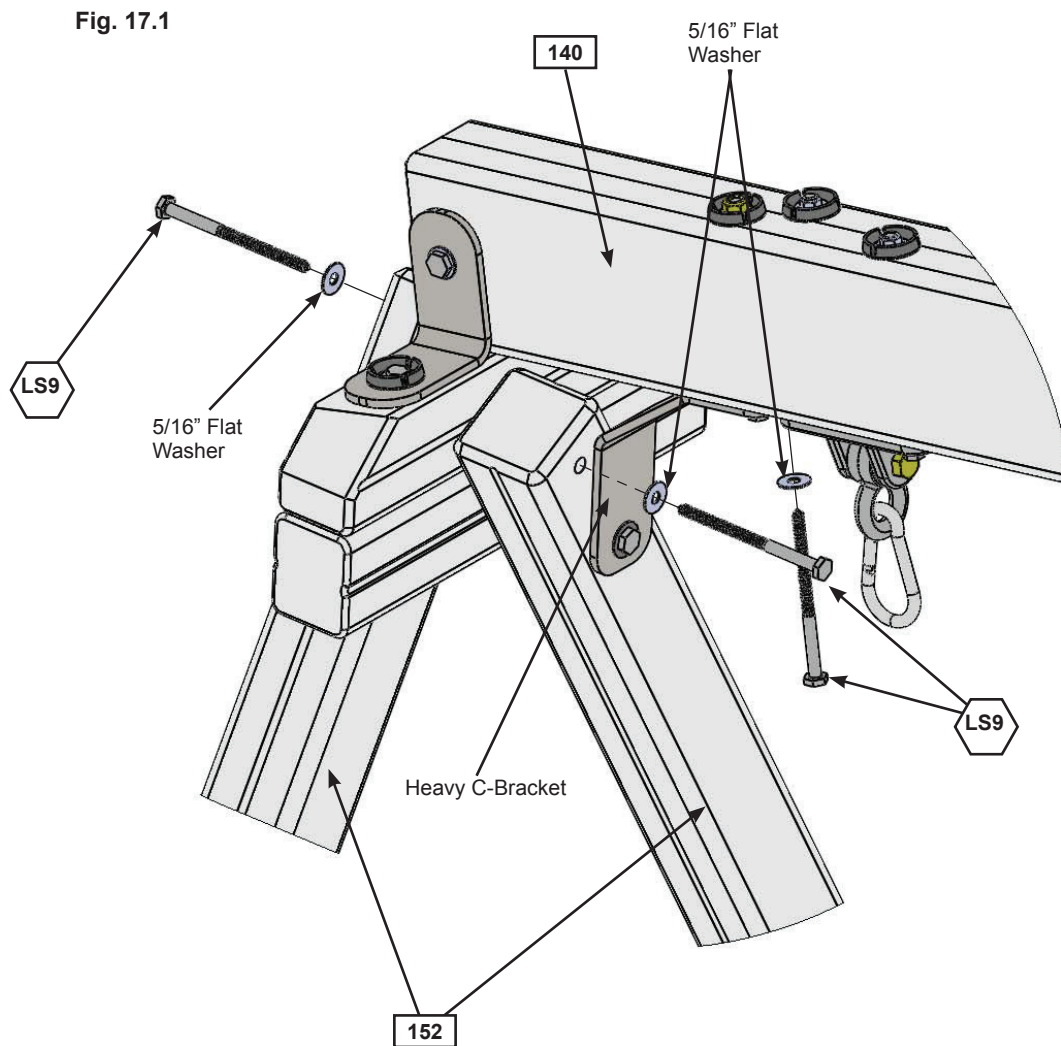

### Hardware

3 x  5/16 x 4-3/4" Lag Screw  
(5/16" flat washer)

## Step 18: Install Ground Stakes

### **MOVE FORT TO FINAL LOCATION PRIOR TO STAKING** **FINAL LOCATION MUST BE LEVEL GROUND**

**A:** In the 5 places shown in fig. 18.1 drive the Rebar Ground Stakes 13" into the ground against (040) Slide End Panel, on the Front, (091) Diagonal, (024) Rock Rail and both (152) SW Posts. Be careful not to hit the washer while hammering stakes into the ground as this could cause the washer to break off.

**B:** Attach ground stakes using 1 (S7) #12 x 2" Pan Screw per ground stake as shown in fig. 18.2.

**C:** After driving stakes into the ground, check for sharp edges caused by the impact of the hammer. Smooth any sharp edges from impact area and touch up with outdoor paint.

**⚠ Warning!** To prevent tipping and avoid potential injury, stakes must be driven 13" into ground. Digging or driving stakes can be dangerous if you do not check first for under-ground wiring, cables or gas lines.

Fig. 18.1

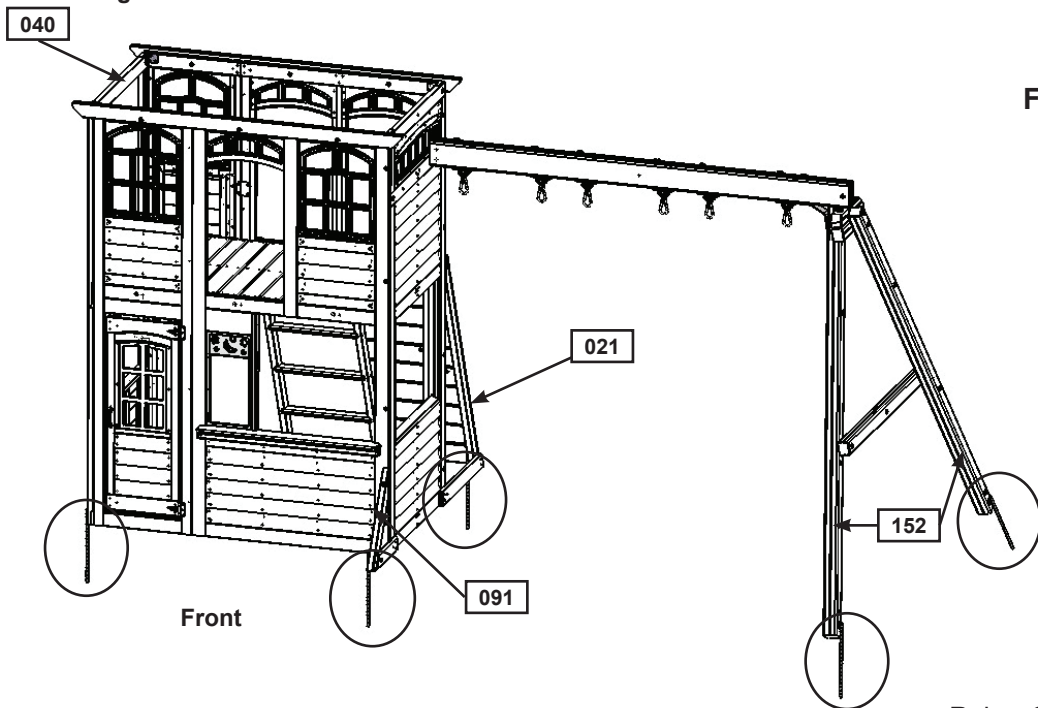
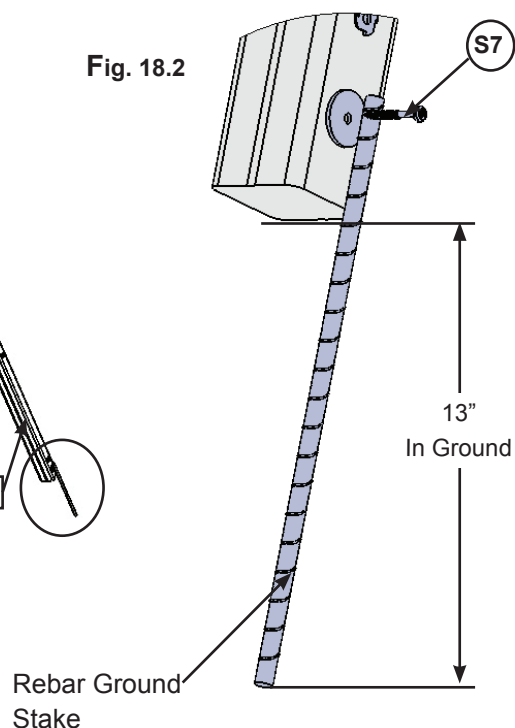

Fig. 18.2



**SEE FRONT COVER FOR  
SAFETY CLEARANCE**

#### Hardware

5 x (S7) #12 x 2" Pan Screw

#### Other Parts

5 x Rebar Ground Stake

# Step 19: Lower Crowsnest Assembly Part 1

**A:** Attach 1 (190) Crowsnest Gusset to 1 (191) Crowsnest Joist so the bottoms and ends are flush with 1 (S7) #12 x 2" Pan Screw. Repeat to make a second set with the (191) Crowsnest Joist on the opposite side from the first. (fig. 19.1 and 19.2)

Fig. 19.1

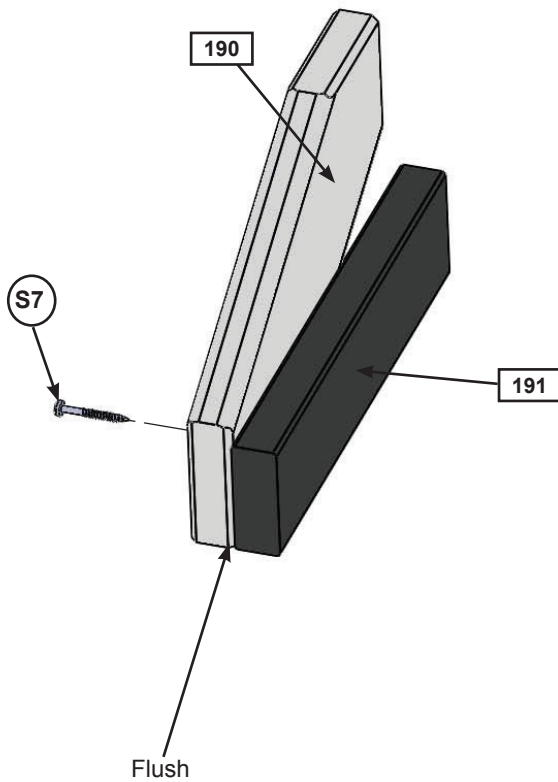
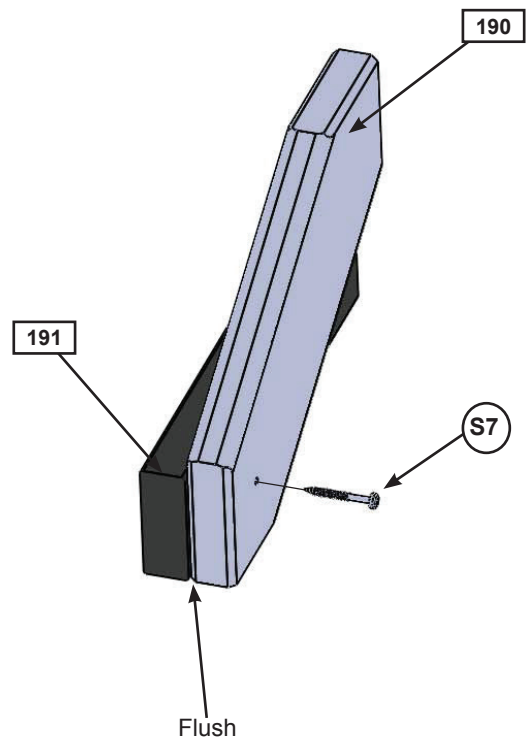

Fig. 19.2



## Wood Parts

- 2 x 190 Crowsnest Gusset 2 x 6 x 15"
- 2 x 191 Crowsnest Joist 2 x 4 x 13-1/2"

## Hardware

- 2 x S7 #12 x 2" Pan Screw



# Step 19: Lower Crowsnest Assembly Part 2

**B:** Place (192) Crowsnest Back against the ends of (191) Crowsnest Joists so the tops are flush then attach with 4 (S3) #8 x 2-1/2" Wood Screws. (fig. 19.3 and 19.4)

Fig. 19.3

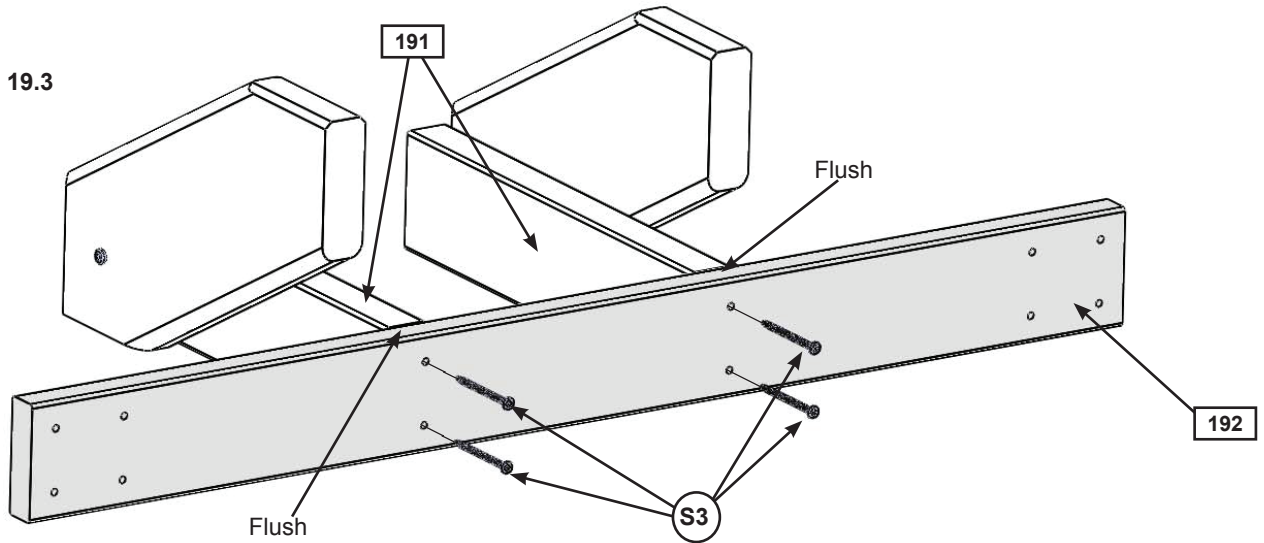
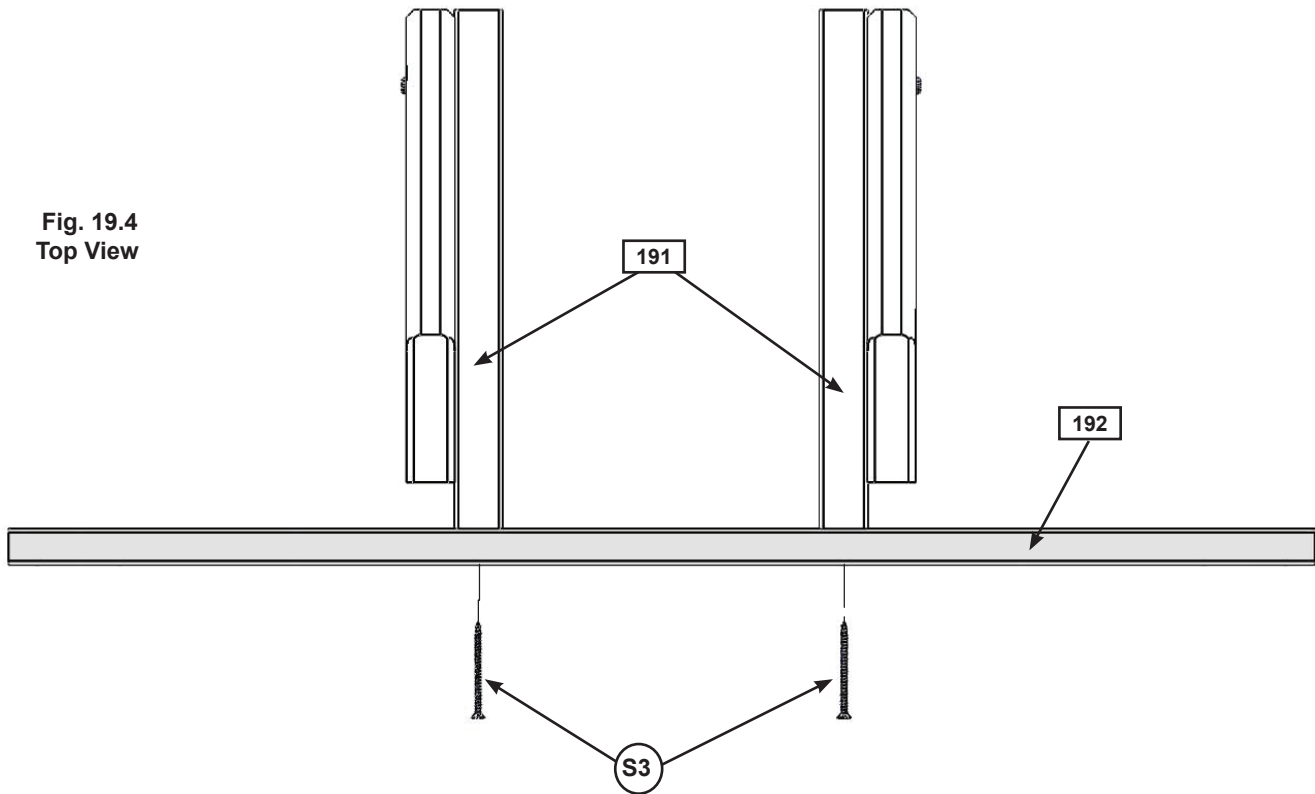

Fig. 19.4  
Top View



**Wood Parts**

1 x 192 Crowsnest Back 5/4 x 4 x 34"

**Hardware**

4 x S3 #8 x 2-1/2" Wood Screw

# Step 20: Upper Crowsnest Assembly Part 1

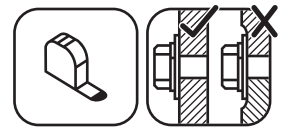

**A:** Loosely attach (200) Crowsnest Top to 2 (201) Upright Crowsnest using 2 (WB9) 5/16 x 2-1/8" Wafer Bolts (with flat washer and t-nut). The distance between uprights must be 25-1/2". (fig. 20.1)

**B:** Loosely attach (202) Crowsnest Front to each (201) Upright Crowsnest using 2 (WB9) 5/16 x 2-1/8" Wafer Bolts (with flat washer and t-nut). The distance between (200) Crowsnest Top and (202) Crowsnest Front must be 27-5/8" (fig. 20.1)

**C:** Double check the dimensions then tighten the bolts. It is important these dimensions are met so there are no issues in future steps.

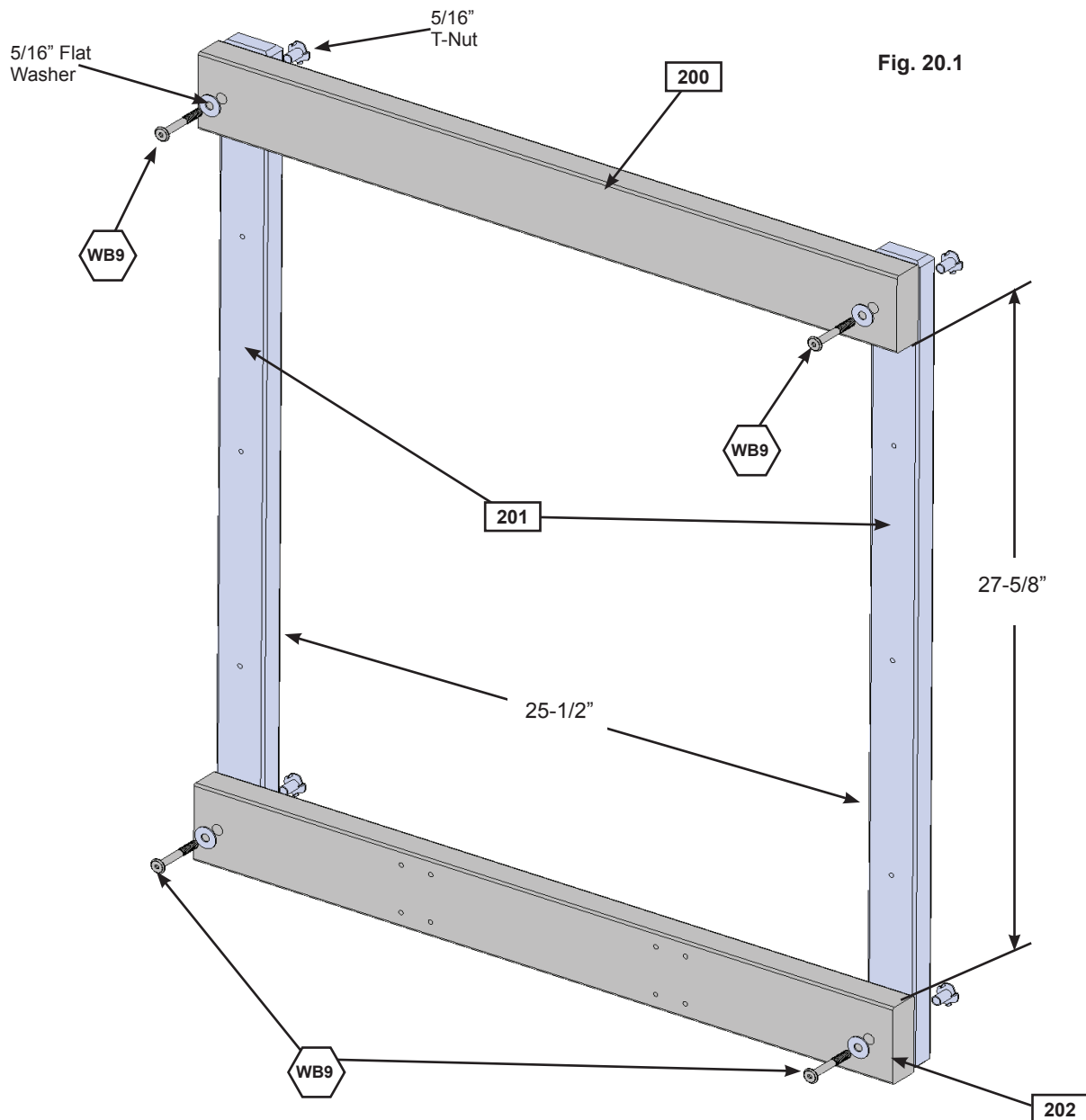

### Wood Parts

- 1 x 200 Crowsnest Top 2 x 4 x 29-1/2"
- 2 x 201 Upright Crowsnest 1 x 2 x 34-1/8"
- 1 x 202 Crowsnest Front 2 x 4 x 29-1/2"

### Hardware

- 4 x WB9 5/16 x 2-1/8" Wafer Bolt  
(5/16" flat washer, 5/16" t-nut)

# Step 20: Upper Crowsnest Assembly Part 2

**D:** Attach 1 (203) Crowsnest Short flush to the top of (200) Crowsnest Top using 6 (S11) #8 x 2" Wood Screws as shown in fig. 20.2.

**E:** Attach 1 (204) Crowsnest Spacer flush to the outside of each (201) Upright Crowsnest using 3 (S11) #8 x 2" Wood Screws per board as shown in fig. 20.2.

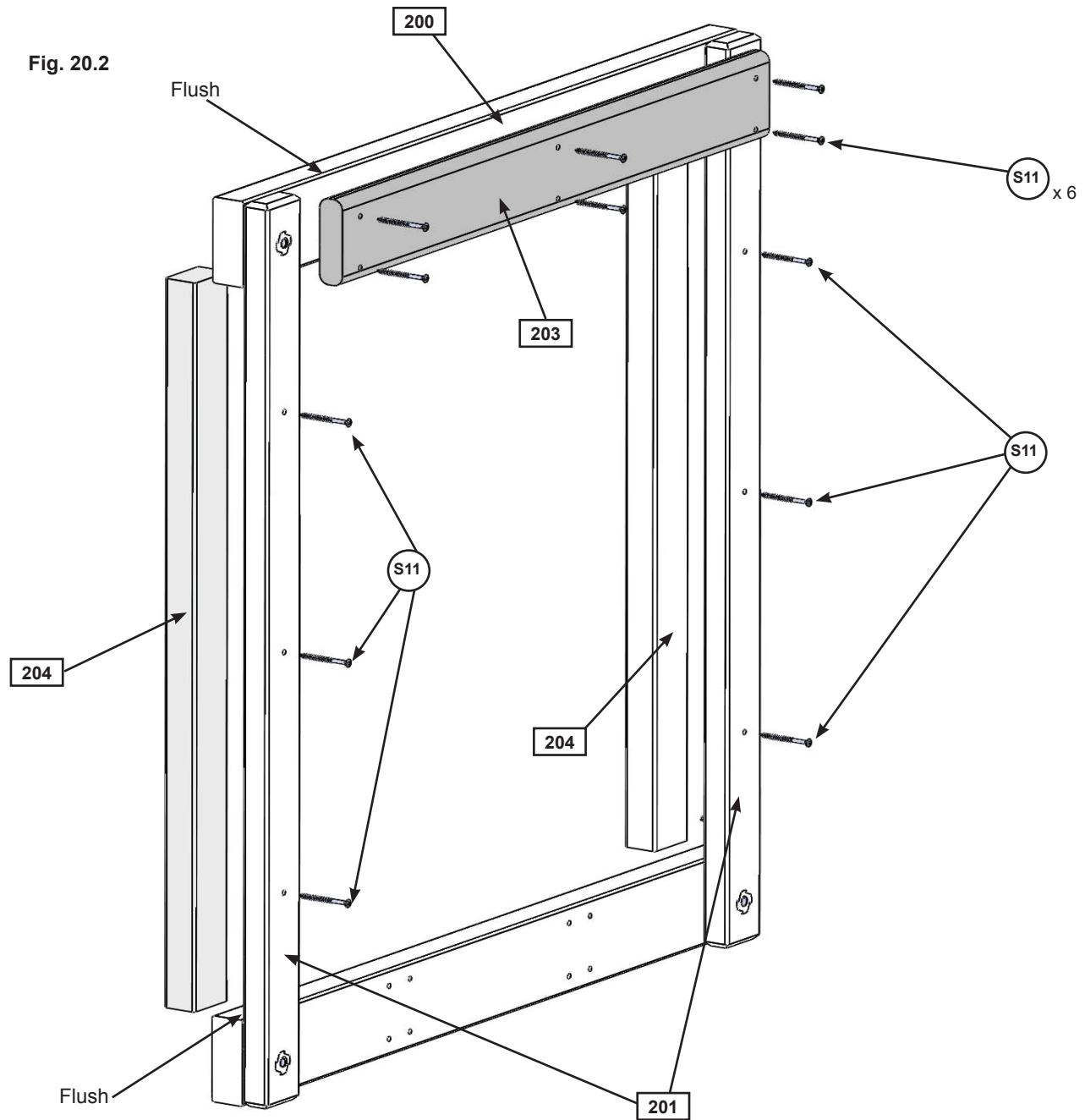

### Wood Parts

- 1 x 203 Crowsnest Short 5/4 x 4 x 25-1/2"
- 2 x 204 Crowsnest Spacer 1-1/4 x 2 x 27-1/2"

### Hardware

- 12 x S11 #8 x 2" Wood Screw

# Step 21: Crowsnest Assembly Part 1

**A:** Attach 1 (210) Crowsnest Bottom Side flush to the inside edge of the panel posts on (040) Slide End Panel and tight to the top of the floor support on (040) Slide End Panel using 3 (S11) #8 x 2" Wood Screws per side. Notice pilot holes towards bottom of boards. (fig. 21.1)

Fig. 21.1

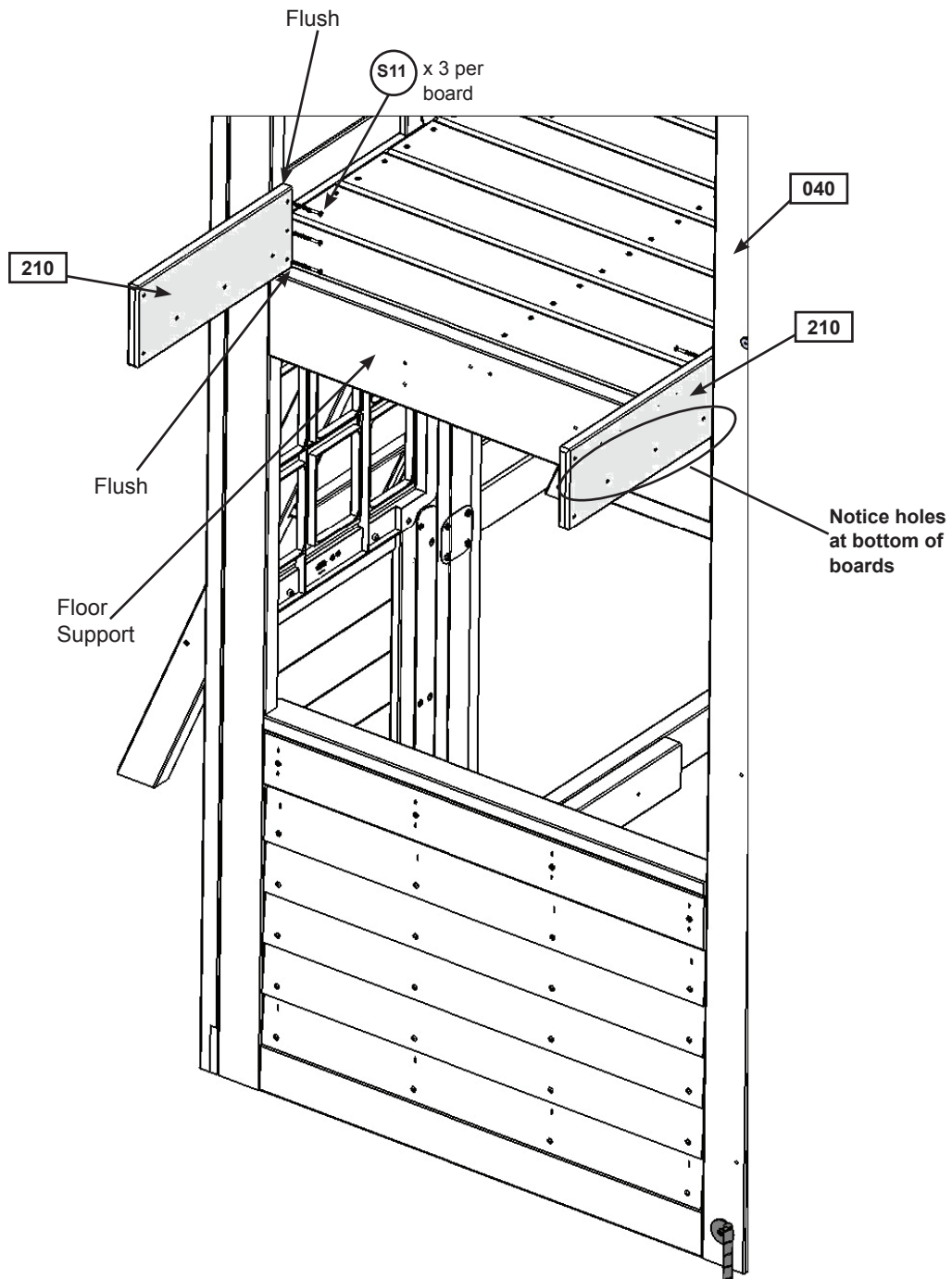

## Wood Parts

2 x 210 Crowsnest Bottom Side 3/4 x 5-1/4 x 14-3/4"

## Hardware

6 x S11 #8 x 2" Wood Screw

# Step 21: Crowsnest Assembly Part 2

**B:** Place the Lower Crowsnest Assembly from Step 19 centred in the opening of (040) Slide End Panel, in between (210) Crowsnest Bottom Sides, tight to the top of the floor boards then attach with 2 (S11) #8 x 2" Wood Screws per side. (fig. 21.2, 21.3 and 21.4)

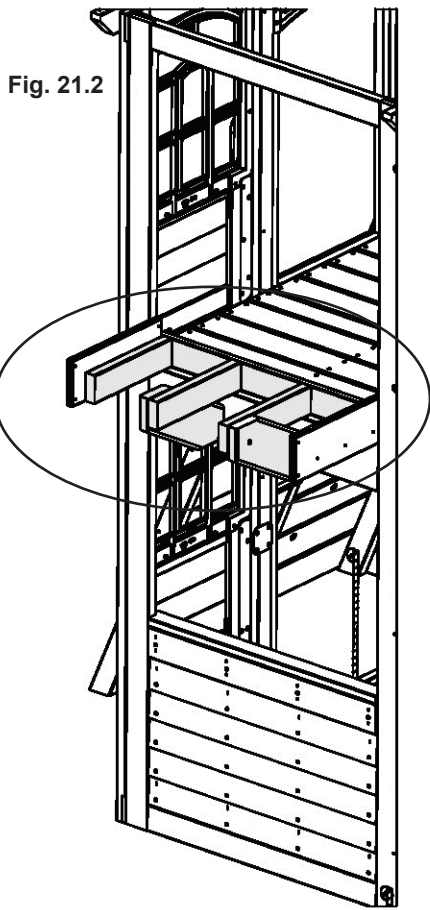

Fig. 21.2

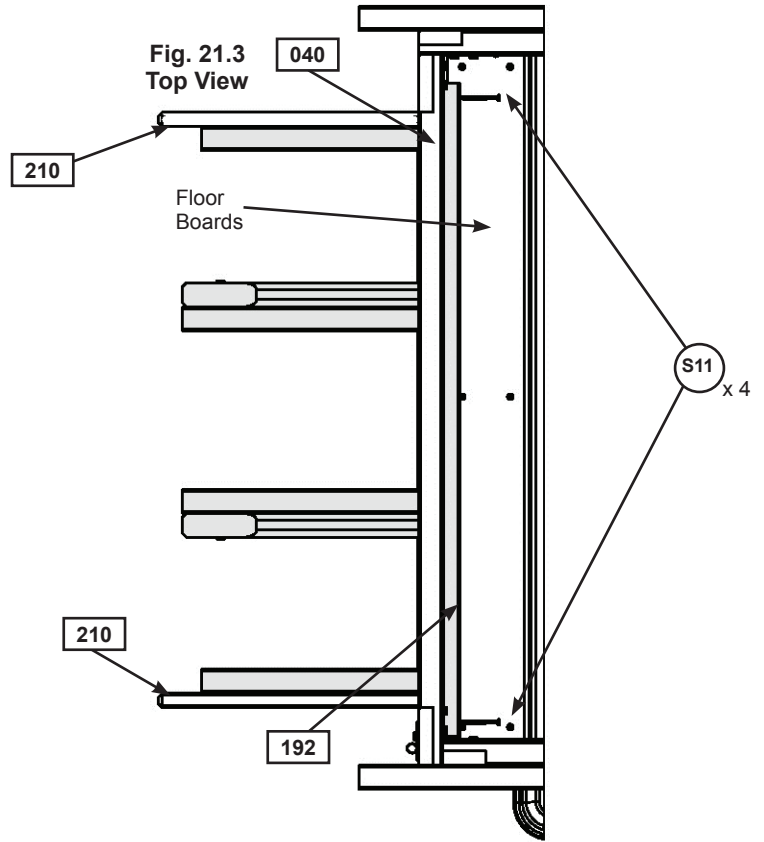
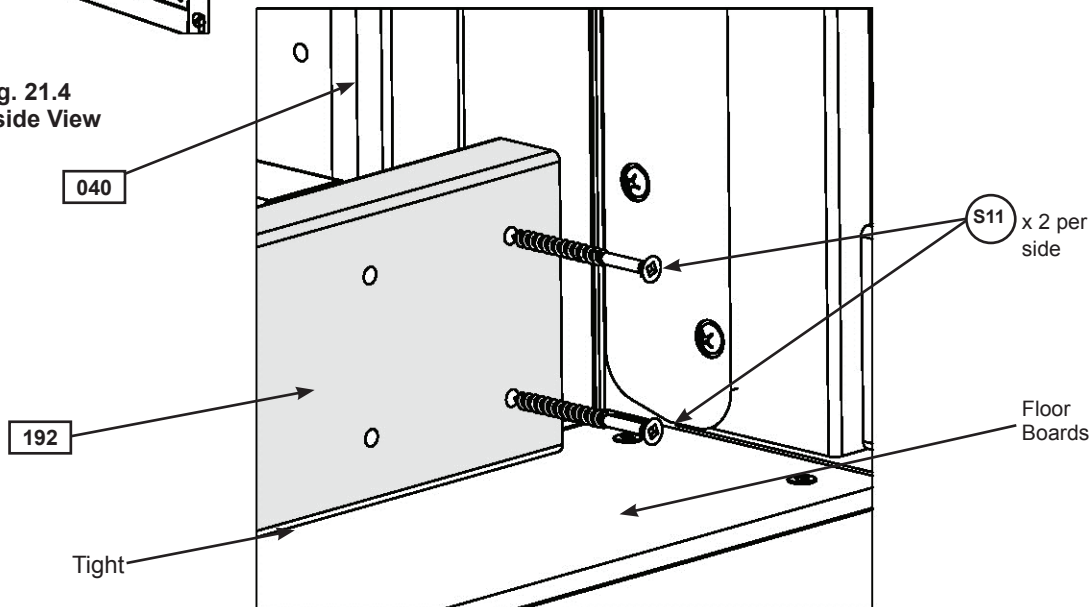

Fig. 21.3  
Top View

Fig. 21.4  
Inside View



### Hardware

4 x (S11) #8 x 2" Wood Screw



# Step 21: Crowsnest Assembly Part 3

**C:** Attach 1 (211) Short Crowsnest Joist tight to (192) Crowsnest Back and flush to the bottom of each (210) Crowsnest Bottom Side using 3 (S20) #8 x 1-3/8" Wood Screws per board as shown in fig. 21.5. Screws to be installed from outside the assembly.

**D:** From inside the assembly attach (192) Crowsnest Back to each (211) Short Crowsnest Joist with 2 (S3) #8 x 2-1/2" Wood Screws per joist. (fig. 21.6)

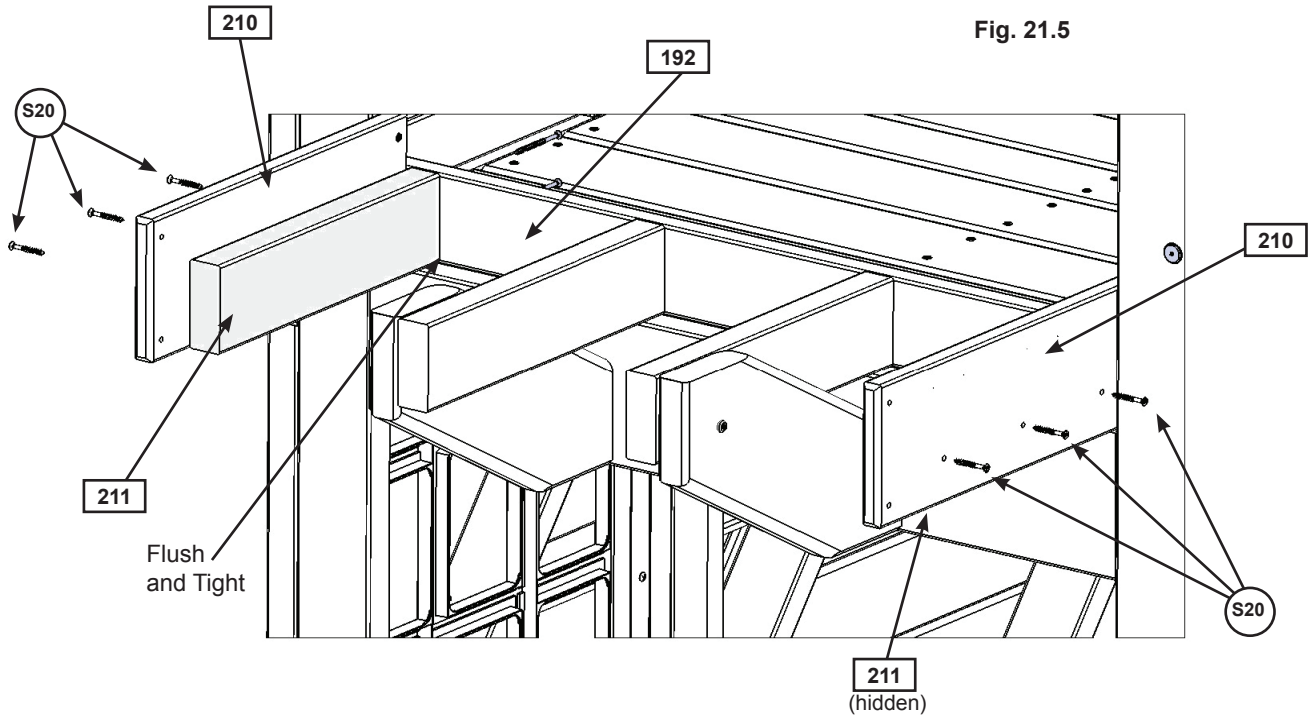
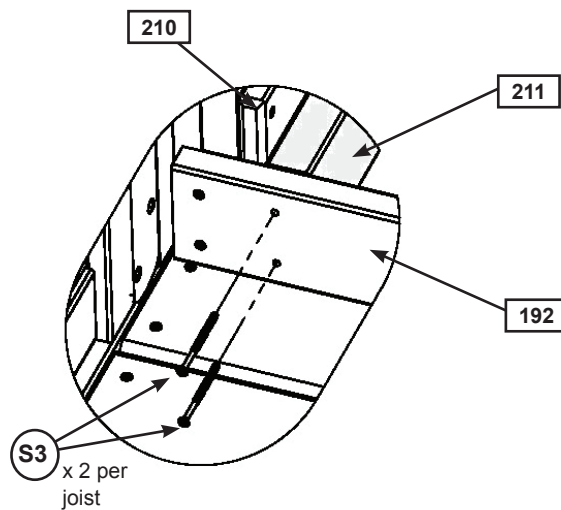

Fig. 21.6  
Inside View



### Wood Parts

2 x **211** Short Crowsnest Joist 2 x 4 x 12-1/2"

### Hardware

6 x **S20** #8 x 1-3/8" Wood Screw

4 x **S3** #8 x 2-1/2" Wood Screw

# Step 21: Crowsnest Assembly Part 4

**E:** Place Upper Crowsnest Assembly from Step 20 in between (210) Crowsnest Bottom Sides so (202) Crowsnest Front is flush to the bottom and front of each (210) Crowsnest Bottom Side and to the tops of (190) Crowsnest Gussets and (191) Crowsnest Joists. Attach with 2 (S11) #8 x 2" Wood Screws per board. Screws go into (202) Crowsnest Front and (204) Crowsnest Spacer. (fig. 21.7)

Fig. 21.7

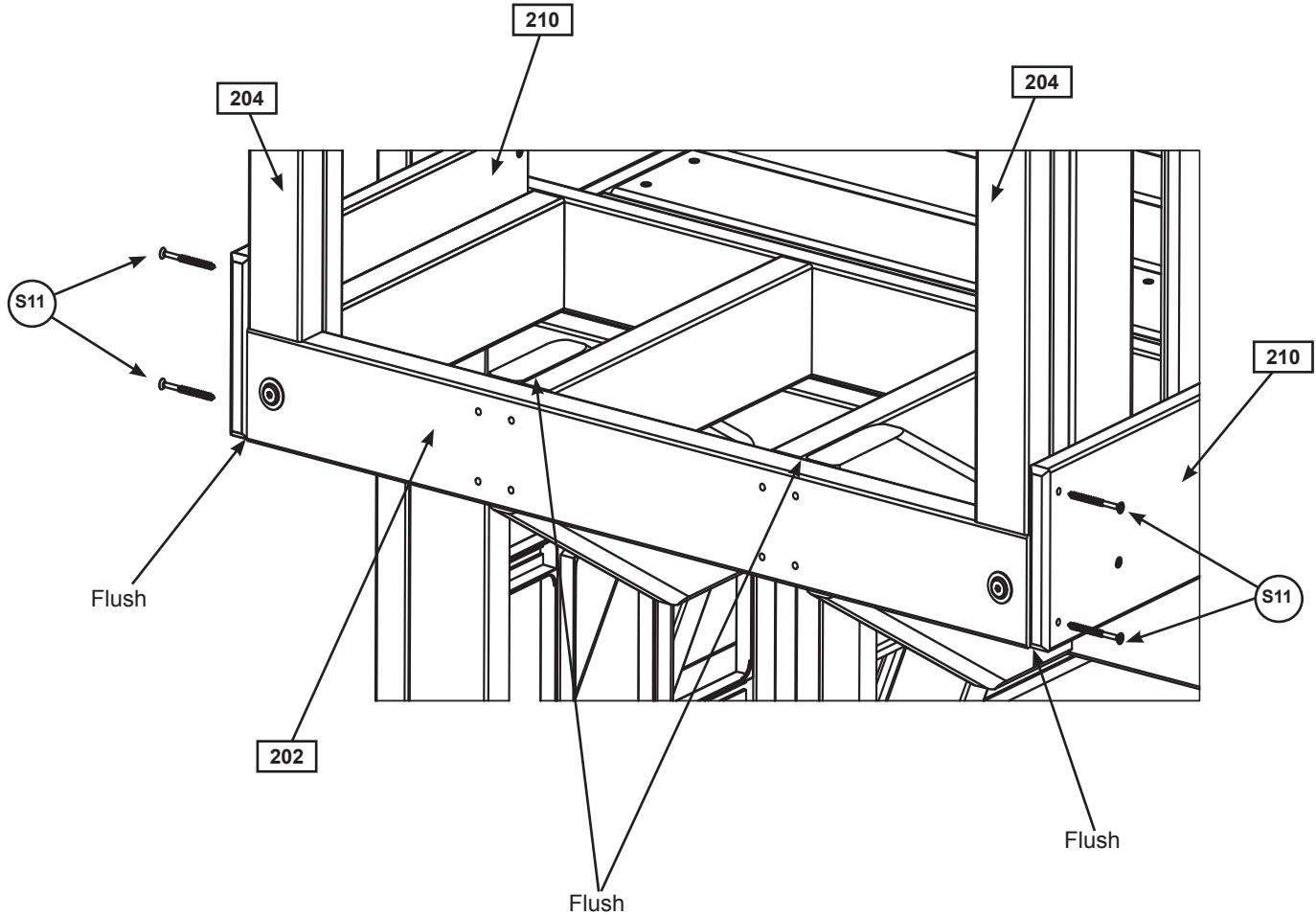

### Hardware

4 x (S11) #8 x 2" Wood Screw

# Step 21: Crowsnest Assembly Part 5

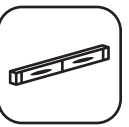

**F:** Attach (202) Crowsnest Front to each (190) Crowsnest Gusset and each (191) Crowsnet Joist with 8 (S4) #8 x 3" Wood Screws. (fig. 21.8)

**G:** Place 1 (212) Crowsnest Side flush to the top and front of (200) Crowsnest Top make sure each board is level then attach with 2 (S3) #8 x 2-1/2" Wood Screws per board. (fig. 21.8)

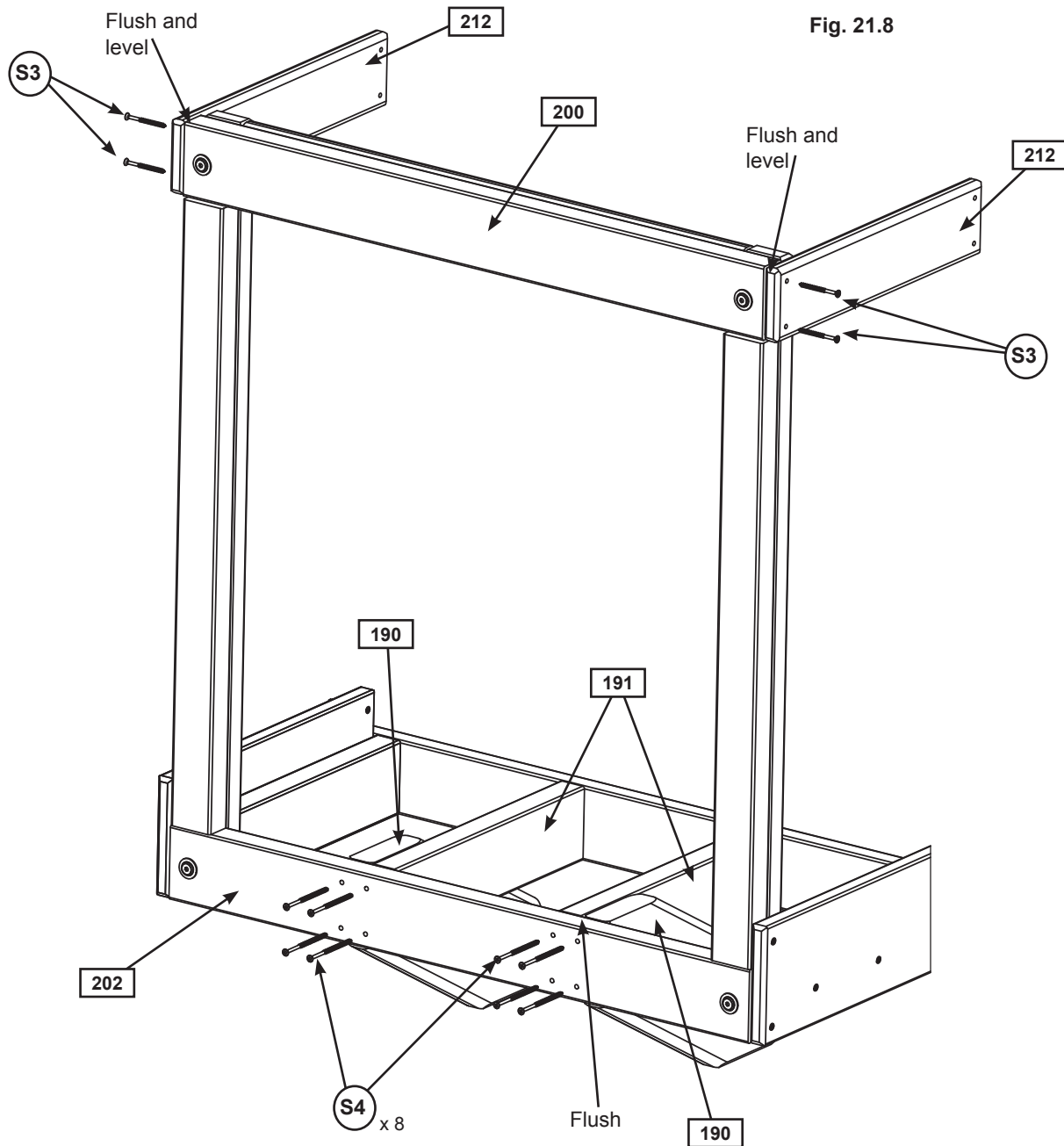

### Wood Parts

2 x **212** Crowsnest Side 3/4 x 3-1/4 x 14-3/4"

### Hardware

8 x **S4** #8 x 3" Wood Screw

4 x **S3** #8 x 2-1/2" Wood Screw

# Step 21: Crowsnest Assembly Part 6



**H:** From inside the assembly attach (040) Slide End Panel to each (190) Crowsnest Gusset with 2 (S4) #8 x 3" Wood Screws per gusset. (fig. 21.9 and 21.10)

**I:** Double check that each (212) Crowsnest Side is level then attach to (040) Slide End Panel flush to the inside of the panel post with 2 (S3) #8 x 2-1/2" Wood Screws per board. (fig. 21.11)

Fig. 21.9  
Top View

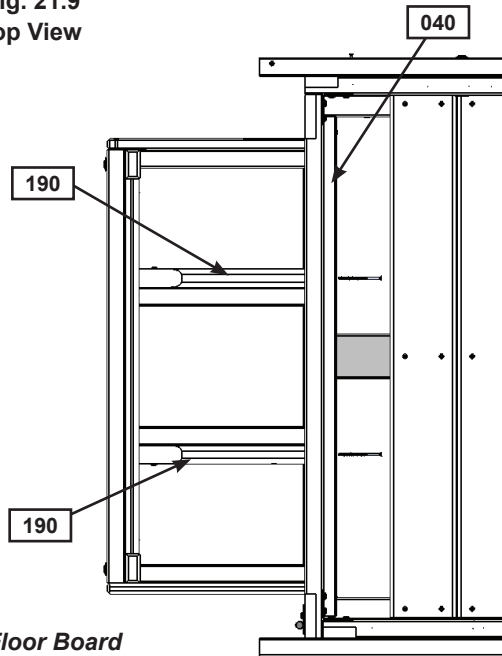

Floor Board  
removed for clarity

Fig. 21.10  
Inside View

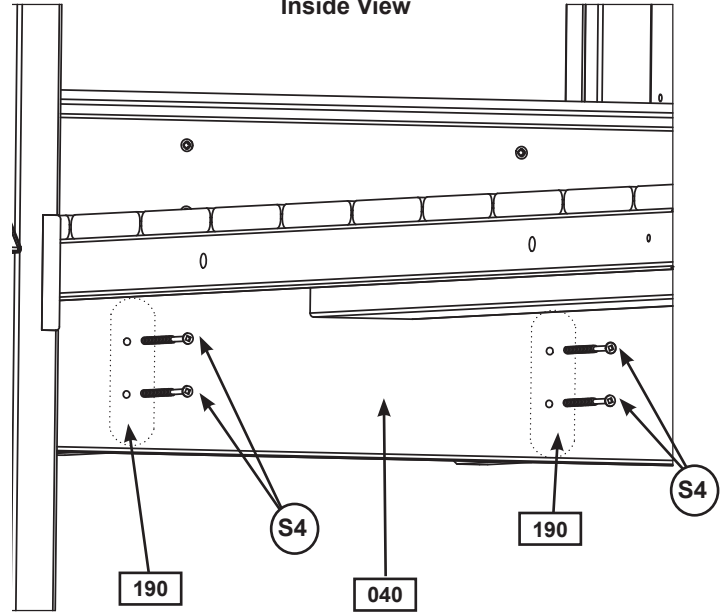
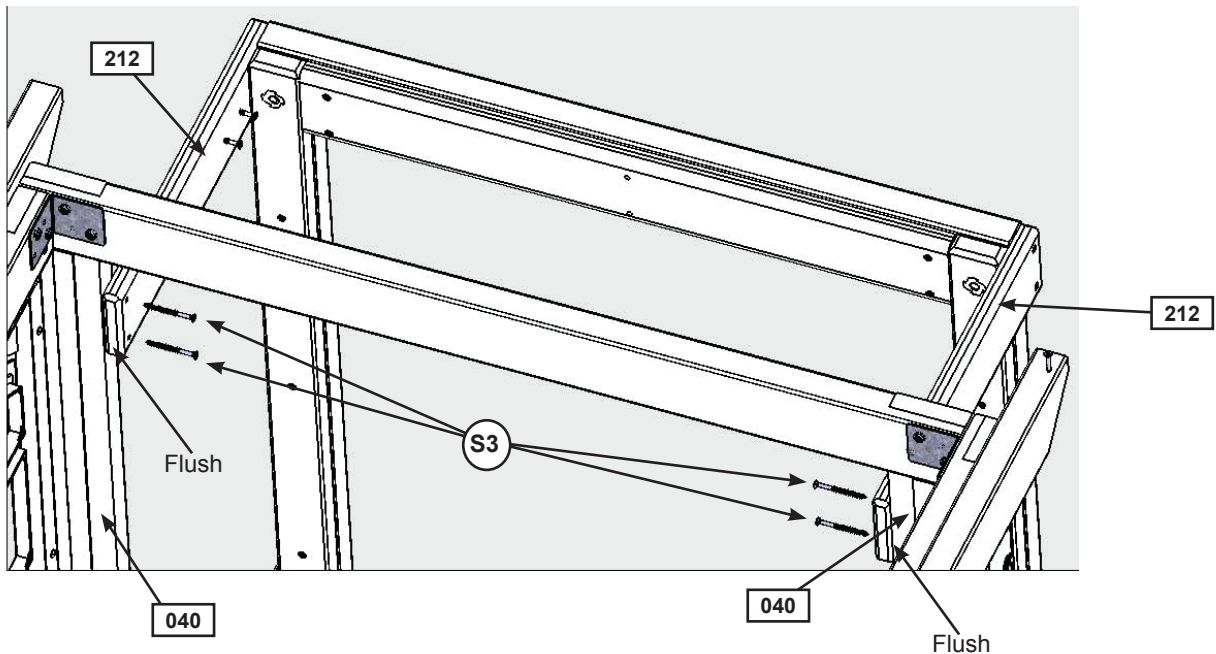

Fig. 21.11



### Hardware

4 x (S4) #8 x 3" Wood Screw

4 x (S3) #8 x 2-1/2" Wood Screw

## Step 22: Crowsnest Floor Assembly

**A:** Lay down (220) Crowsnest Gap Board flush to front of (202) Crowsnest Front and (221) Crowsnest Floor flush to back of (192) Crowsnest Back. In between the gap and floor boards place another (221) Crowsnest Floor. (fig. 22.1)

**B:** Attach the (221) Crowsnest Floor Boards with 8 (S20) #8 x 1-3/8" Wood Screws per board and the (220) Crowsnest Gap Board with 6 (S20) #8 x 1-3/8" Wood Screws. (fig. 22.1)

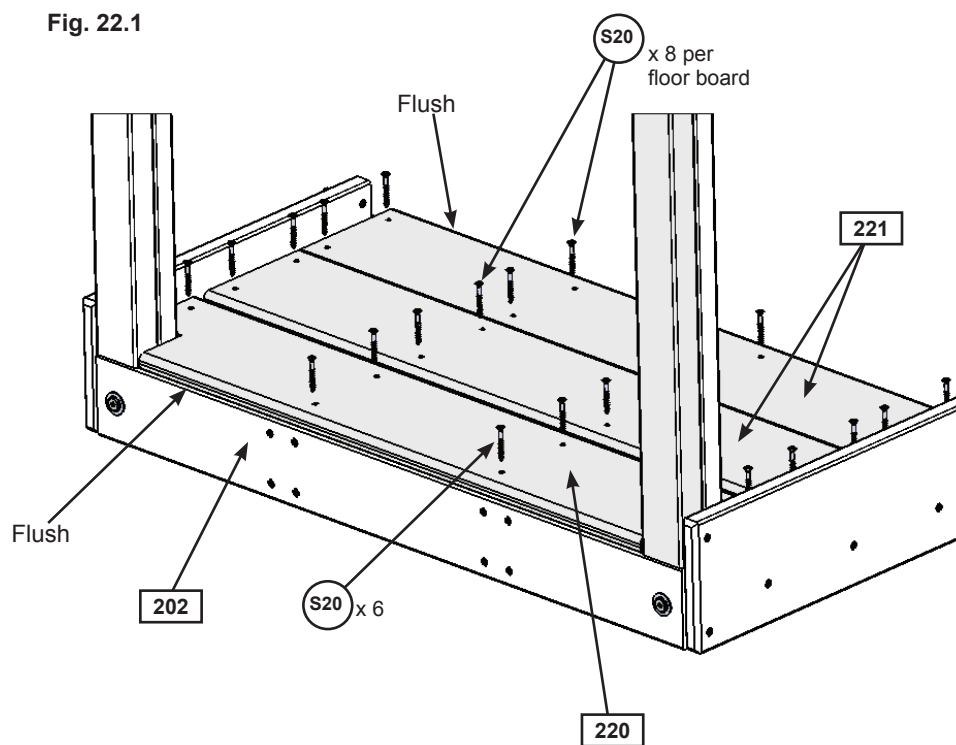

### Wood Parts

- 1 x 220 Crowsnest Gap Board 1 x 6 x 29-3/8"
- 2 x 221 Crowsnest Floor 1 x 6 x 29-3/8"

### Hardware

- 22 x S20 #8 x 1-3/8" Wood Screw



# Step 23: Crowsnest Wall Assembly



**A:** Tight to each (201) Upright Crowsnest and tight to the floor and gap boards attach 1 (230) Cedar Wall to each (210) Crowsnest Bottom Side and (212) Crowsnest Side with 4 (S33) #8 x 1" Wood Screws per board. (fig. 23.1)

**B:** Measure 2-1/4" from each (230) Cedar Wall then attach another (230) Cedar Wall per side, tight to the floor and gap boards using 4 (S33) #8 x 1" Wood Screws per board. (fig. 23.1)

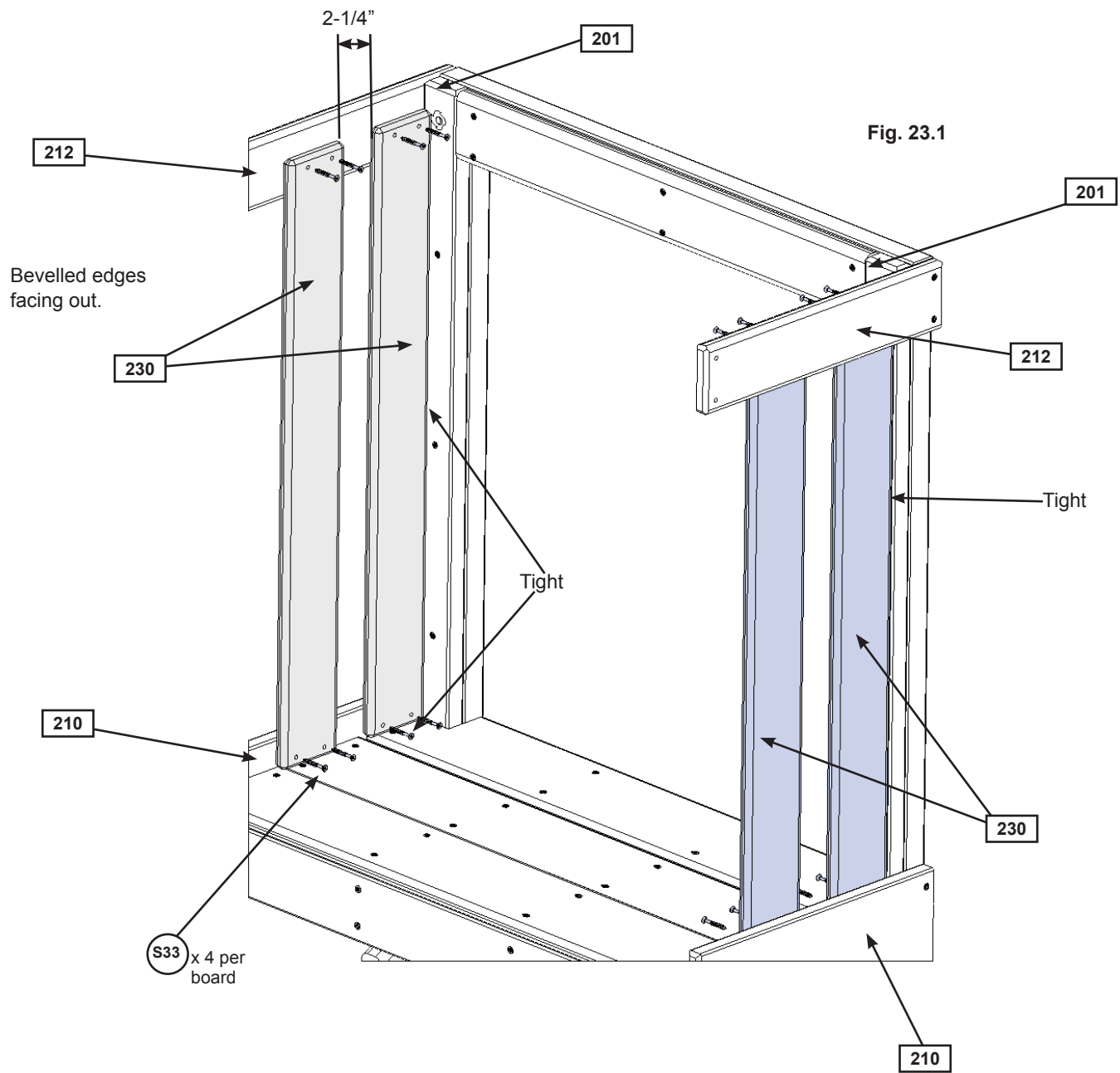

Fig. 23.1

**Wood Parts**

4 x 230 Cedar Wall 1 x 4 x 29"

**Hardware**

16 x S33 #8 x 1" Wood Screw

# Step 24: Slide Section Assemblies Part 1



**Note:** When installing Pan Bolts make sure to look at holes so bolts go through the side with the round recess and the lock nuts go through the side with the hexagonal recess. (fig. 24.3)

**A:** Fit 2 TNR2 Slide Elbows together and attach with 8 (PB1) 1/4 x 3/4" Pan Bolts (with lock nut) as shown in fig. 24.1. It is very important to attach bolts as indicated.

**B:** Repeat Step A 3 more times to create 4 Elbow Sections in total.

**C:** Attach TNR2 Slide RT Flange and TNR2 Slide LT Flange together using 4 (PB1) 1/4 x 3/4" Pan Bolts (with lock nut) as shown in fig. 24.2. This creates the Flange Assembly.

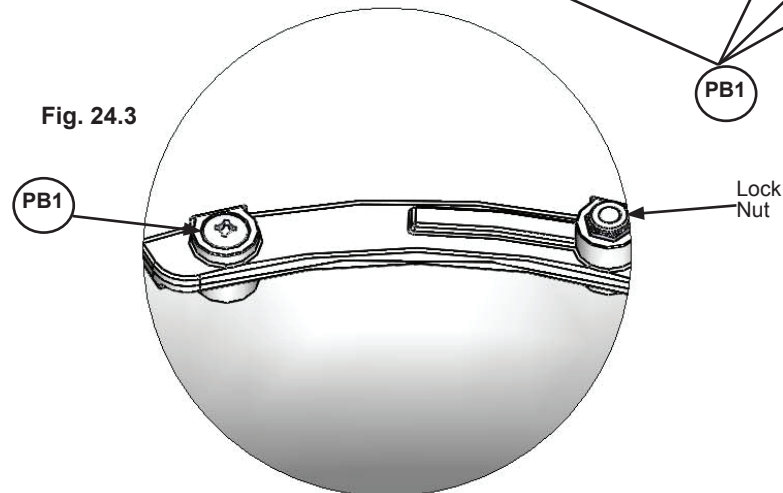
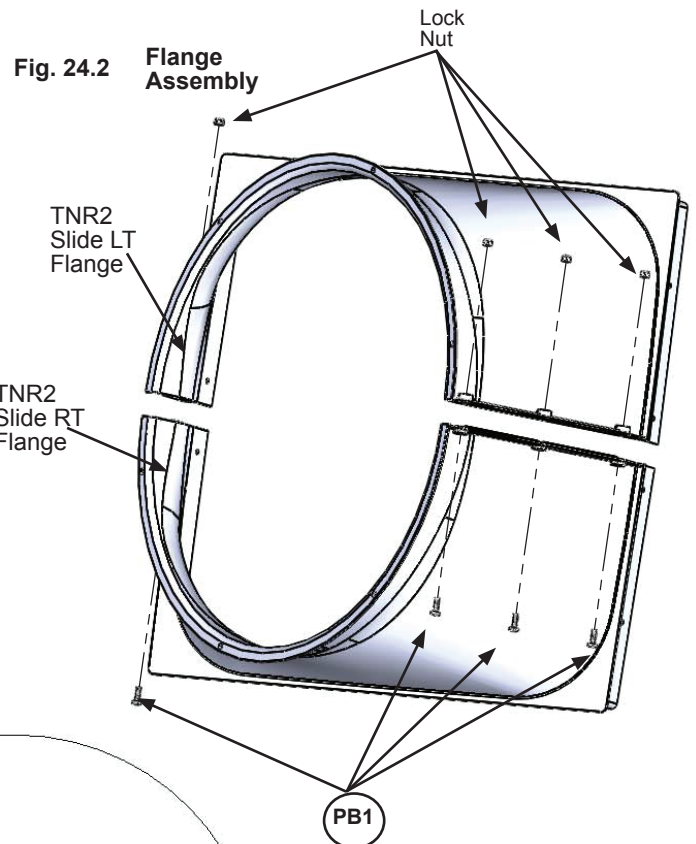
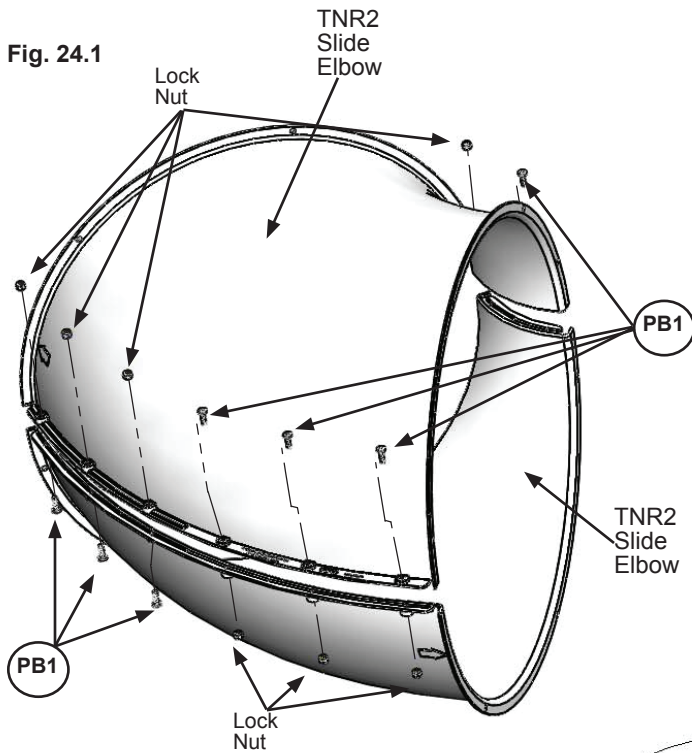

Use a 7/16" open end wrench for nuts

### Hardware

36 x  1/4 x 3/4" Pan Bolt  
(1/4" lock nut)

### Other Parts

1 x TNR2 Slide LT Flange  
1 x TNR2 Slide RT Flange  
8 x TNR2 Slide Elbow

## Step 24: Slide Section Assemblies Part 2

**Note:** When installing Pan Bolts make sure to look at holes so bolts go through the side with the round recess and the lock nuts go through the side with the hexagonal recess. (fig. 24.3)

**D:** Attach TNR2 Slide Exit Top and the remaining TNR2 Slide Elbow together using 8 (PB1) 1/4 x 3/4" Pan Bolts (with lock nut) as shown in fig. 24.4. It is very important to attach bolts as indicated. This creates the Exit Elbow Assembly.

Fig. 24.4

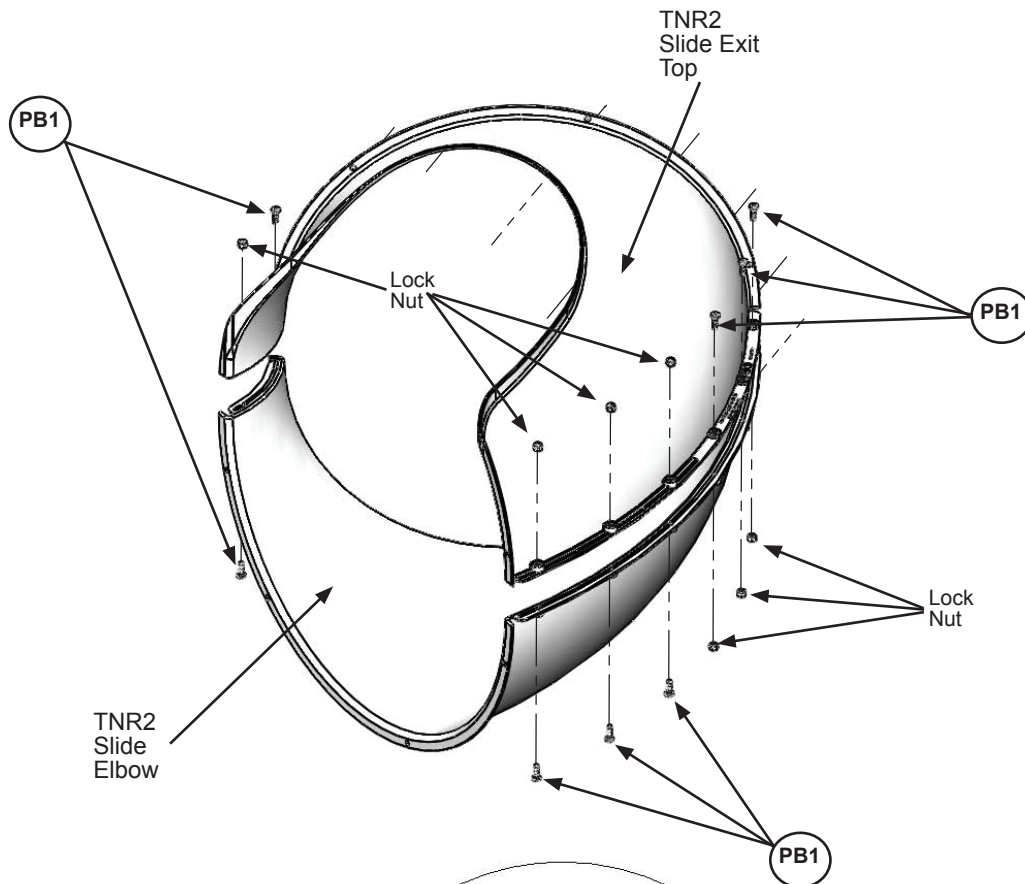
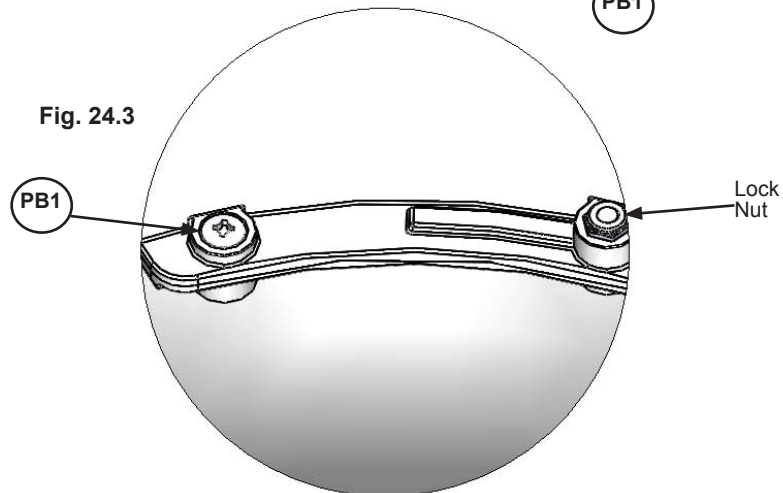



Fig. 24.3



### Hardware

8 x  1/4 x 3/4" Pan Bolt  
(1/4" lock nut)

### Other Parts

1 x TNR2 Slide Exit Top  
1 x TNR2 Slide Elbow

# Step 25: Attach Flange Assembly to Fort

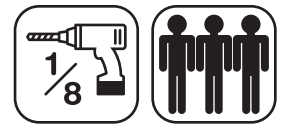

**A:** With a helper place the Flange Assembly flush to the Crowsnest on the fort as shown in fig. 25.1 and 25.5, then pre-drill 1/8" pilot holes in the bottom 4 mounting locations on (220) Crowsnest Gap Board (approximate spots where circles are on figure), making sure the pre-drilled holes are a minimum of 1" deep.

**B:** Attach Flange Assembly to the Crowsnest through (220) Crowsnest Gap Board and into (202) Crowsnest Front using 4 (S7) #12 x 2" Pan Screws (with #12 Screw Bezel) in the pre-drilled holes. (fig. 25.1 and 25.2) Make sure the flat surfaces of the Flange Assembly are flush to the Crowsnest as shown in fig. 25.5.

**C:** Attach the Flange Assembly flush to (200) Crowsnest Top using 4 (S6) #12 x 1" Pan Screws (with #12 Screw Bezel) as shown in fig. 25.1 and 25.3 and to both (204) Crowsnest Spacers using 5 (S6) #12 x 1" Pan Screw per board. (fig. 25.1 and 25.4)

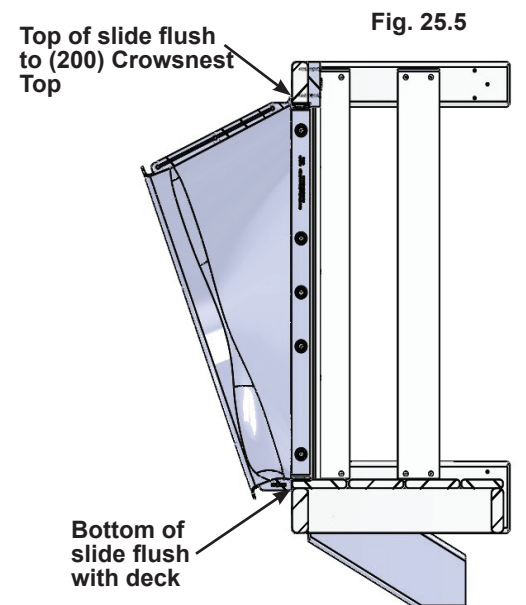
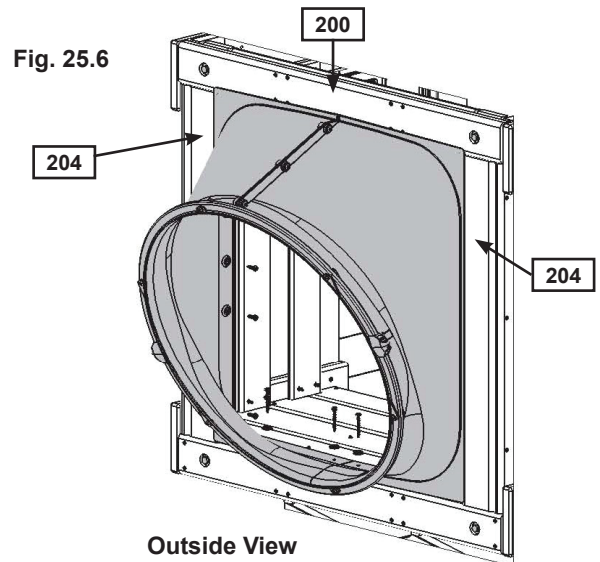
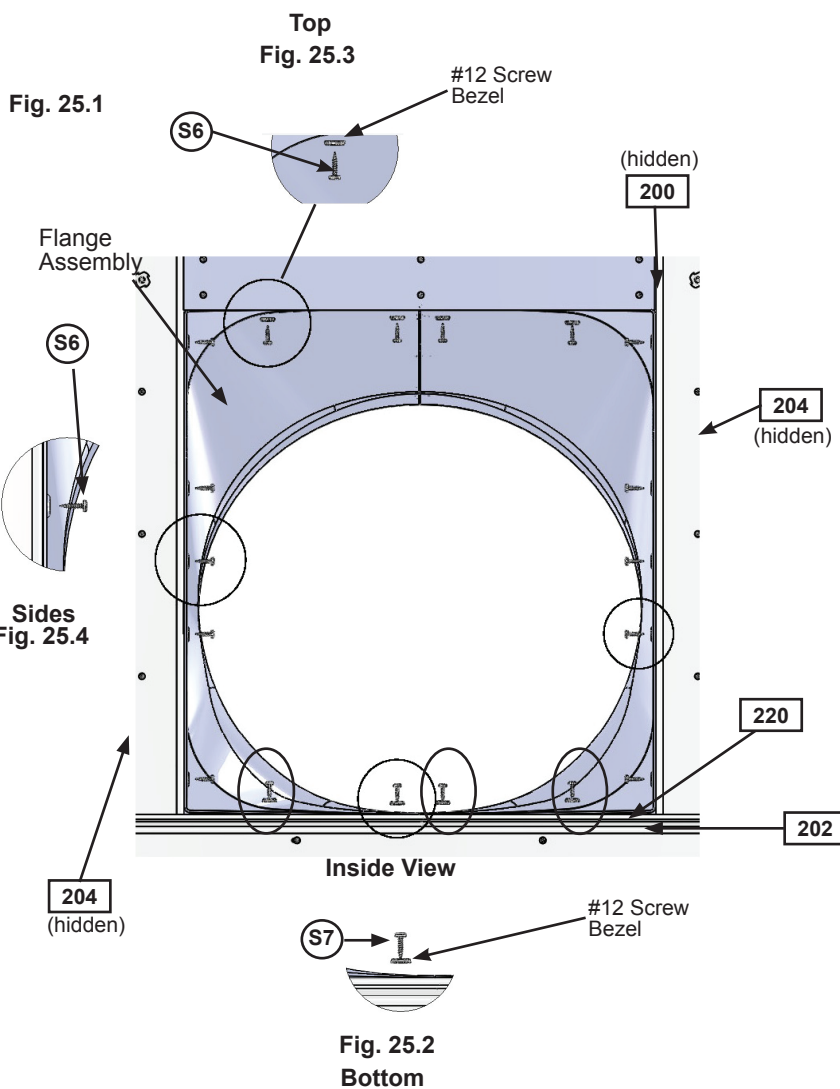

## Hardware

- 14 x (S6) #12 x 1" Pan Screw
- 4 x (S7) #12 x 2" Pan Screw
- 8 x #12 Screw Bezel

# Step 26: Attach Elbow Assembly to Flange Assembly Part 1



**Note:** When installing Pan Bolts make sure to look at holes so bolts go through the side with the round recess and the lock nuts go through the side with the hexagonal recess. Keep all bolts loose until further step.

**A:** Fit one of the Elbow Assemblies to the Flange Assembly by lining up the arrows on each assembly. (fig. 26.2 and 26.3)

**B:** Attach 1 TNR2 Slide Clamp Ring to the top of the joined Assemblies using 3 (PB1) 1/4 x 3/4" Pan Bolts (with lock nut), making sure to match the arrows up with the end of the clamp ring (where a seam will be) as shown in fig. 26.2 and 26.3.

Use Quadrex Driver as a guide pin for each hole before inserting bolt. (fig. 26.3)

Quadrex Driver



Use special driver provided in locations where the curve of the elbow are difficult to reach with a standard driver.

Fig. 26.1

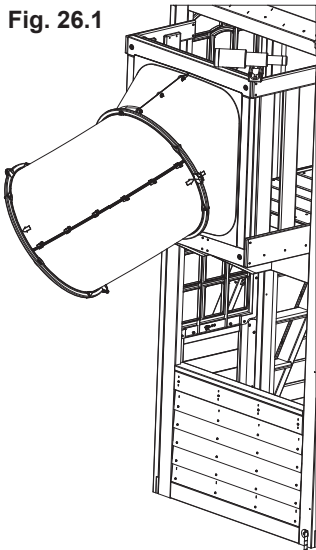
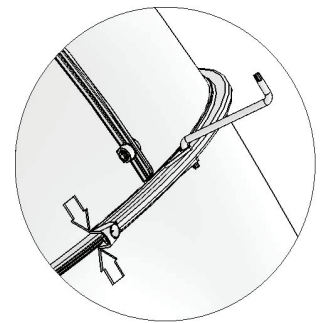

Fig. 26.4



Do not install bolt in Clamp Ring ends until Step 26D

Fig. 26.3



Align each elbow using the molded arrows with the seam of the clamp ring.

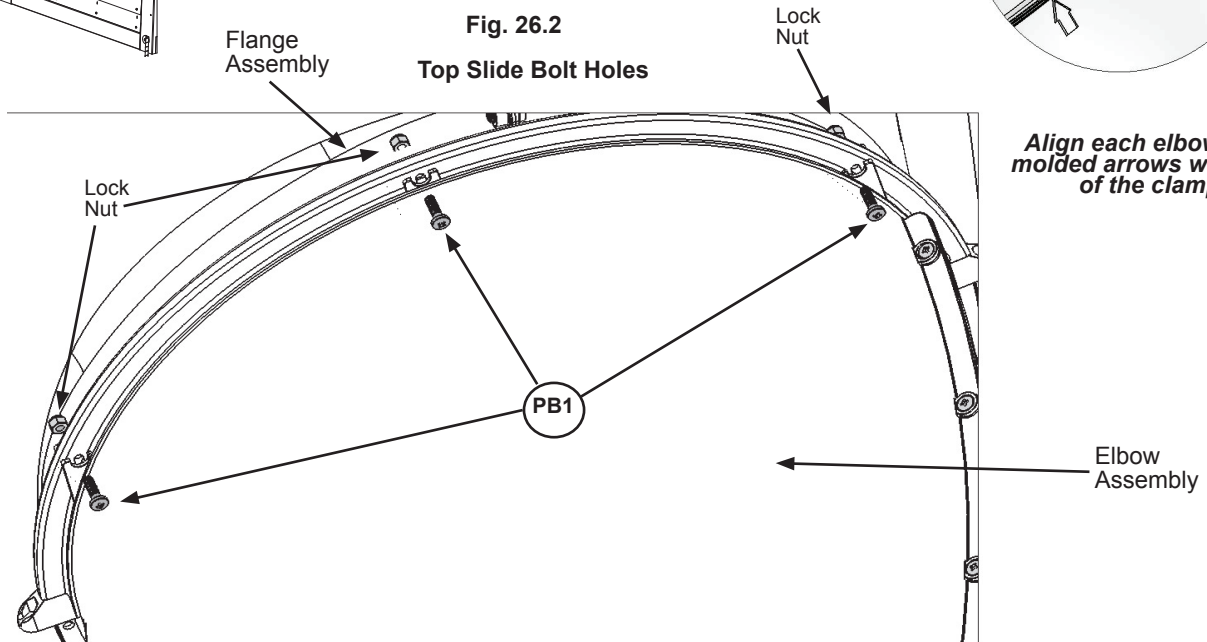

### Hardware

3 x (PB1) 1/4 x 3/4" Pan Bolt  
(1/4" lock nut)

### Other Parts

1 x Quadrex Driver  
1 x TNR2 Slide Clamp Ring



# Step 26: Attach Elbow Assembly to Flange Assembly Part 2



**Note:** When installing Pan Bolts make sure to look at holes so bolts go through the side with the round recess and the lock nuts go through the side with the hexagonal recess. Keep all bolts loose until further step.

**C:** Attach 1 TNR2 Slide Clamp Ring to the bottom of the joined Assemblies using 2 (PB1) 1/4 x 3/4" Pan Bolts (with lock nut) on one side and 1 (PB1) 1/4 x 3/4" Pan Bolt (with lock nut) in the other side, making sure to match the arrows up with the end of the clamp ring (where a seam will be) as shown in fig. 26.5, 26.6 and 26.7.

**D:** Connect the 2 TNR2 Slide Clamp Rings together in 2 spots using 1 (PB1) 1/4 x 3/4" Pan Bolt (with lock nut) per hole. Make sure seams and arrows line up and then tighten all bolts. (fig. 26.8 and 26.9).

Fig. 26.5

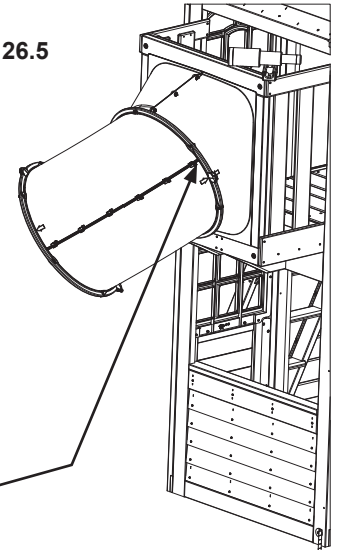

Fig. 26.6

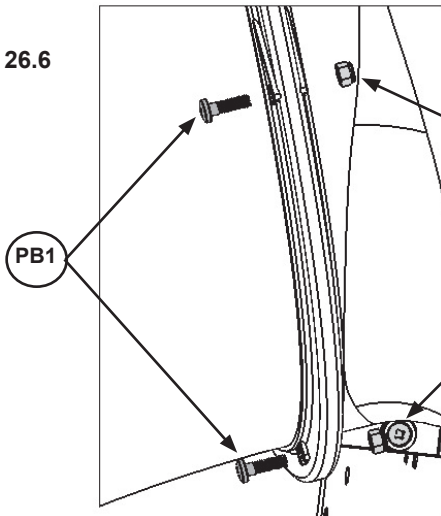

Fig. 26.7 (Side not shown)

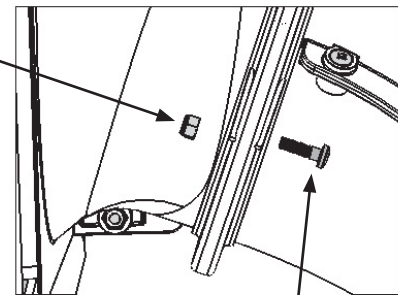

Fig. 26.8

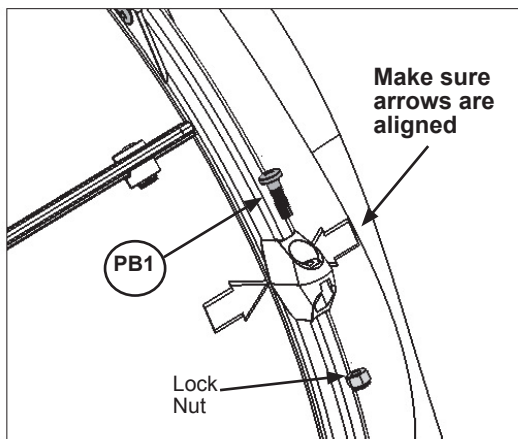
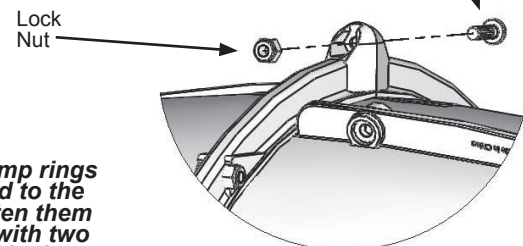

Fig. 26.9



*After the clamp rings are attached to the elbows, fasten them end to end with two pan bolts and lock nuts*

### Hardware

5 x (PB1) 1/4 x 3/4" Pan Bolt  
(1/4" lock nut)

### Other Parts

1 x TNR2 Slide Clamp Ring

# Step 27: Attach Elbow Assembly to Elbow Assembly Part 1



**Note:** When installing Pan Bolts make sure to look at holes so bolts go through the side with the round recess and the lock nuts go through the side with the hexagonal recess. Keep all bolts loose until further step.

**A:** Fit a second Elbow Assembly to the first Elbow Assembly by lining up the arrows on each assembly. Notice the elbow orientation. (fig. 27.1)

**B:** Attach 1 TNR2 Slide Clamp Ring to the top of the joined Assemblies using 3 (PB1) 1/4 x 3/4" Pan Bolts (with lock nut), making sure to match the arrows up with the end of the clamp ring (where a seam will be) as shown in fig. 27.2 and 27.3.

**Use Quadrex Driver as a guide pin for each hole before inserting bolt.**

Fig. 27.1

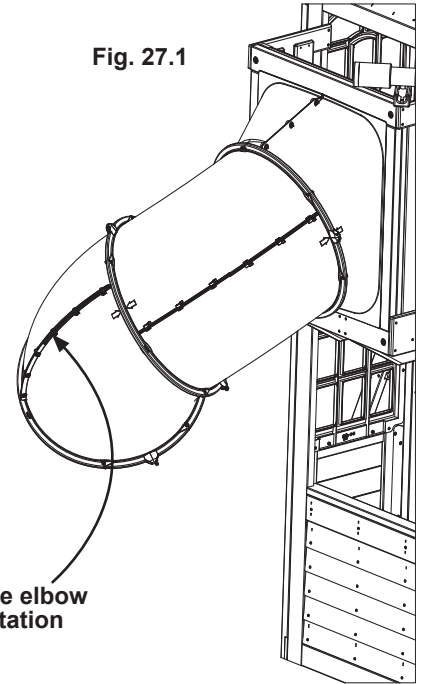

Notice elbow orientation



Do not install bolt in Clamp Ring ends until Step 27D

Fig. 27.2  
Top Slide Bolt Holes

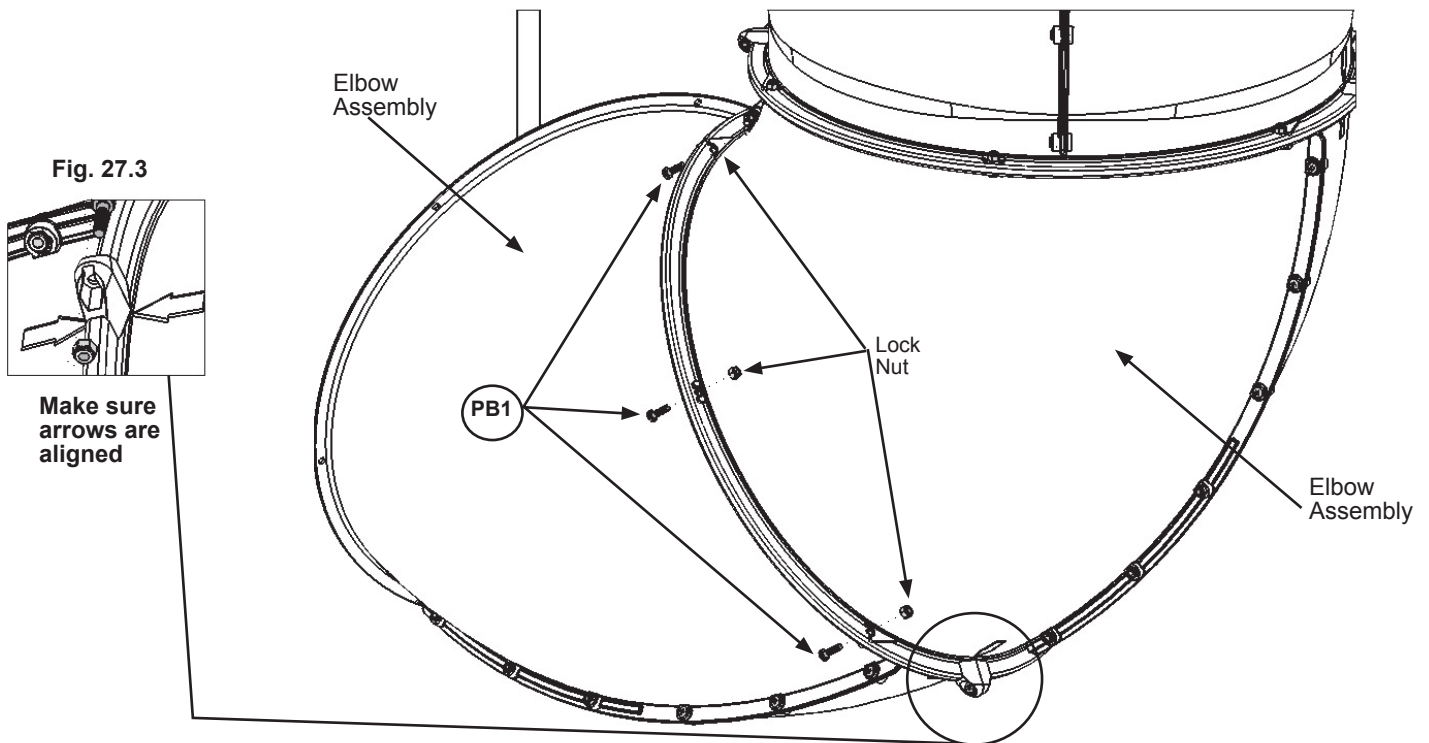
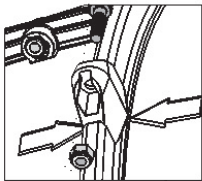

Fig. 27.3



Make sure arrows are aligned

### Hardware

3 x (PB1) 1/4 x 3/4" Pan Bolt (1/4" lock nut)

### Other Parts

1 x TNR2 Slide Clamp Ring

# Step 27: Attach Elbow Assembly to Elbow Assembly Part 2



**Note:** When installing Pan Bolts make sure to look at holes so bolts go through the side with the round recess and the lock nuts go through the side with the hexagonal recess. Keep all bolts loose until further step.

**C:** Attach 1 TNR2 Slide Clamp Ring to the bottom of the joined Assemblies using 3 (PB1) 1/4 x 3/4" Pan Bolts (with lock nut), making sure to match the arrows up with the end of the clamp ring (where a seam will be) as shown in fig. 27.3 and 27.4.

**D:** Connect the 2 TNR2 Slide Clamp Rings together in 2 spots using 1 (PB1) 1/4 x 3/4" Pan Bolt (with lock nut) per hole. Make sure seams and arrows line up and then tighten all bolts. (fig. 27.3 and 27.5).

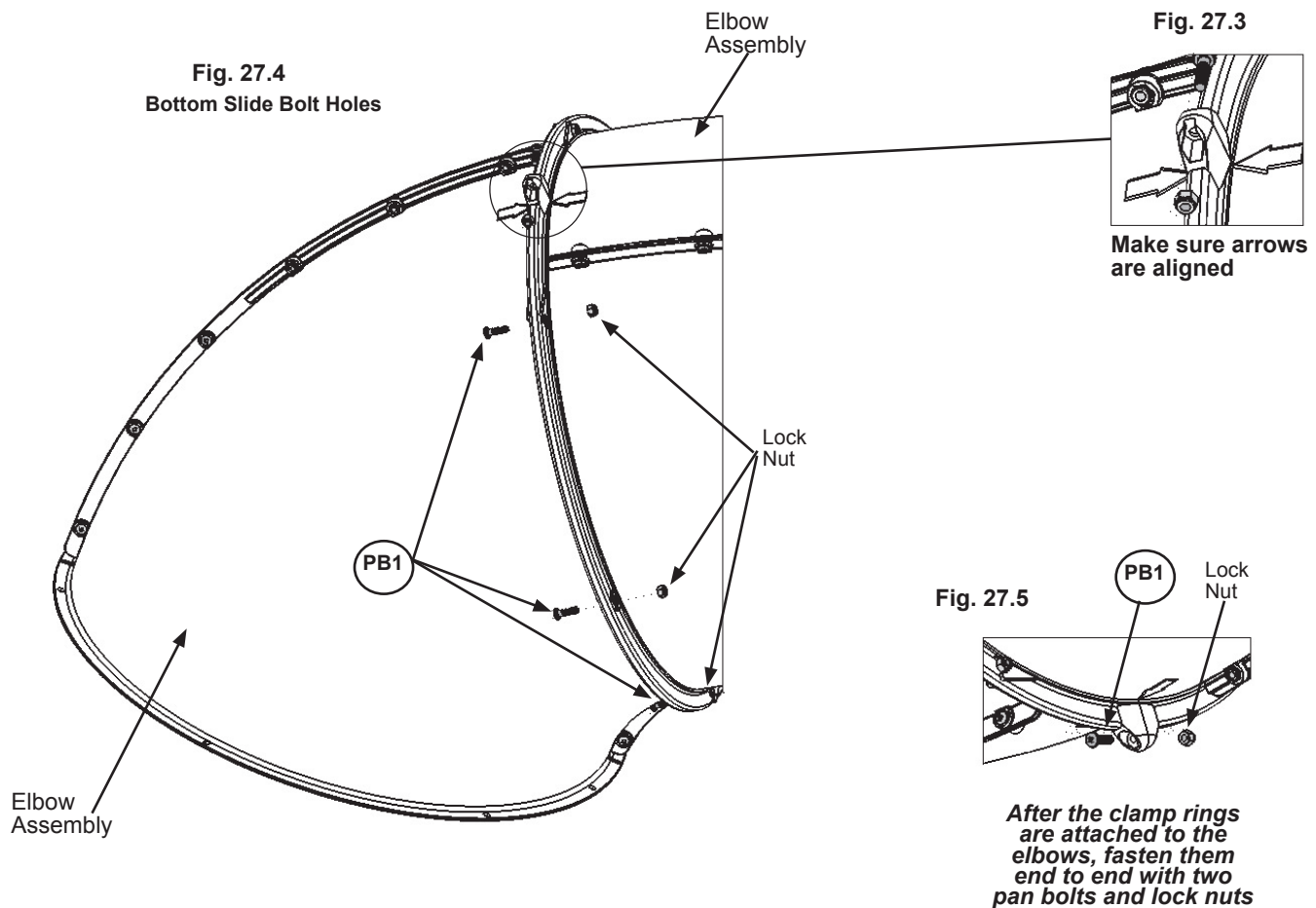

### Hardware

5 x (PB1) 1/4 x 3/4" Pan Bolt  
(1/4" lock nut)

### Other Parts

1 x TNR2 Slide Clamp Ring

# Step 28: TNR Brace Assembly

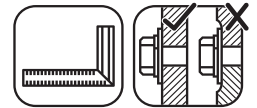

**A:** Attach (281) TNR Upright to (280) TNR Ground Brace with 1 (H8) 1/4 x 4-1/4" Hex Bolt (with lock washer, flat washer and t-nut) in the top hole. Make sure both boards are square then attach with 1 (S11) #8 x 2" Wood Screw. (fig. 28.1)

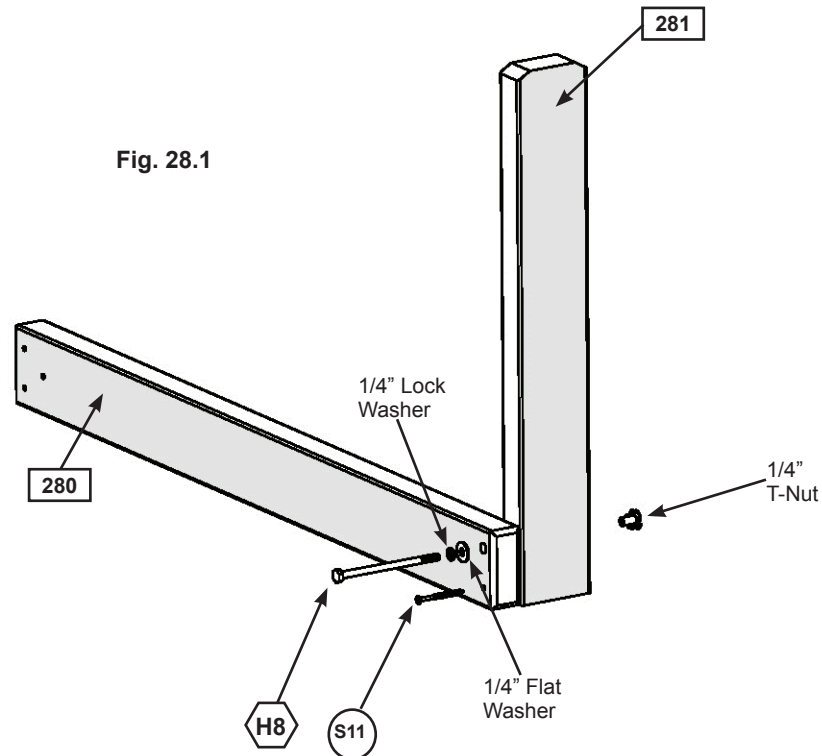

### Wood Parts

- 1 x 280 TNR Ground Brace 1-1/4 x 3 x 32-1/4"
- 1 x 281 TNR Upright 1-1/4 x 3 x 20-1/4"

### Hardware

- 1 x S11 #8 x 2" Wood Screw
- 1 x H8 1/4 x 4-1/4" Hex Bolt (1/4" lock washer, 1/4" flat washer, 1/4" t-nut)

# Step 29: Attach Elbow Assemblies and TNR2 Slide Support



**Note:** When installing Pan Bolts make sure to look at holes so bolts go through the side with the round recess and the lock nuts go through the side with the hexagonal recess. Keep all bolts loose until further step.

**A:** Attach the two remaining Elbow Assemblies as instructed in Steps 26 and 27.

**B:** Place TNR Brace Assembly against (041) Narrow Back Panel so it sits under the slide. It is not attached yet. (fig. 29.1)

**C:** On the fourth attached Elbow Assembly remove the pan bolt and nut which is facing the fort (installed in Step 24). (fig. 29.1) **The bolt will no longer be needed, but keep the lock nut.**

**D:** Loosely attach TNR3 Tube Support (at the slightly bent end) to the Clamp Ring using 1 (PB6) 1/4 x 1" Pan Bolt (with flat washer and the previously removed lock nut). (fig. 29.2)

**E:** Rotate TNR3 Tube Support and attach to (040) Slide End Panel using 1 (S6) #12 x 1" Pan Screw as shown in fig. 29.2.

**F:** Fully tighten screw and bolt.

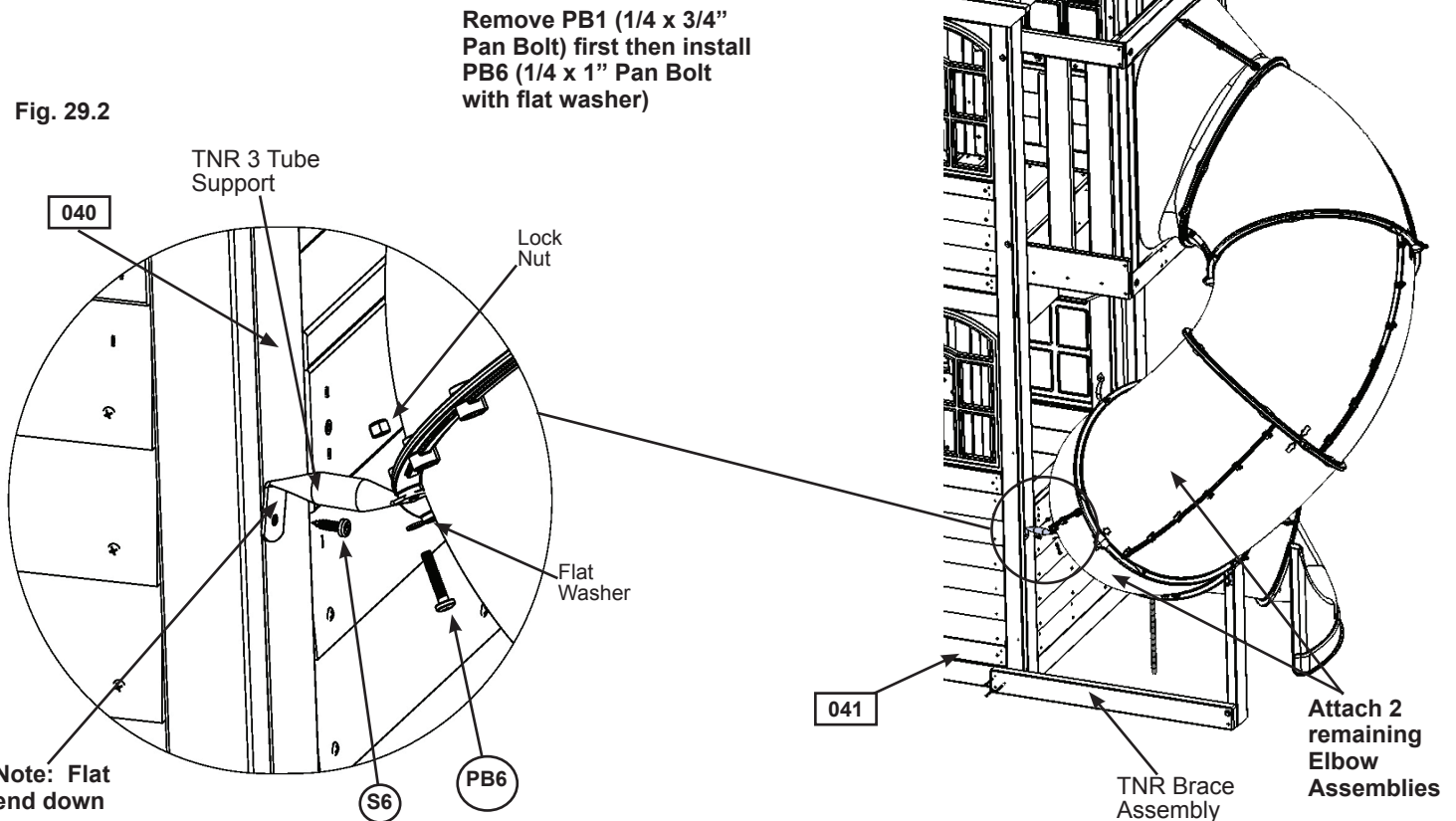

### Hardware

- 1 x (S6) #12 x 1" Pan Screw
- 1 x (PB6) 1/4 x 1" Pan Bolt (1/4" flat washer & 1/4" lock nut - previously removed)
- 16 x (PB1) 1/4 x 3/4" Pan Bolt (1/4" lock nut)

### Other Parts

- 1 x TNR3 Tube Support
- 4 x TNR2 Slide Clamp Ring



# Step 30: Attach TNR Brace Assembly

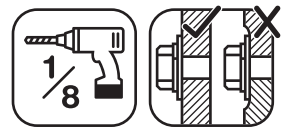

**A:** Use (281) TNR Upright as a guide to judge the proper bolt location, remove the bottom pan bolt and nut. **The bolt will no longer be needed, but keep the lock nut.** (fig. 30.1 and 30.2)

**B:** Attach the top of the TNR3 Post Mount to TNR2 Slide Clamp Ring using 1 (PB2) 1/4 x 1-1/4" Pan Bolt (with the previously removed lock nut). (fig. 30.2)

**C:** Insert TNR3 Post Mount on (281) TNR Upright, pre-drill with a 1/8" drill bit then attach with 2 (S6) #12 x 1" Pan Screws. (fig. 30.3)

**D:** Attach (280) TNR Ground Brace flush to the bottom of (041) Narrow Back Panel with 2 (S11) #8 x 2" Wood Screws and 1 (S4) #8 x 3" Wood Screw. (fig. 30.1 and 30.4)

Fig. 30.1

Remove PB1 (1/4 x 3/4" Pan Bolt) first then install PB2 (1/4 x 1-1/4" Pan Bolt with previously removed lock nut)

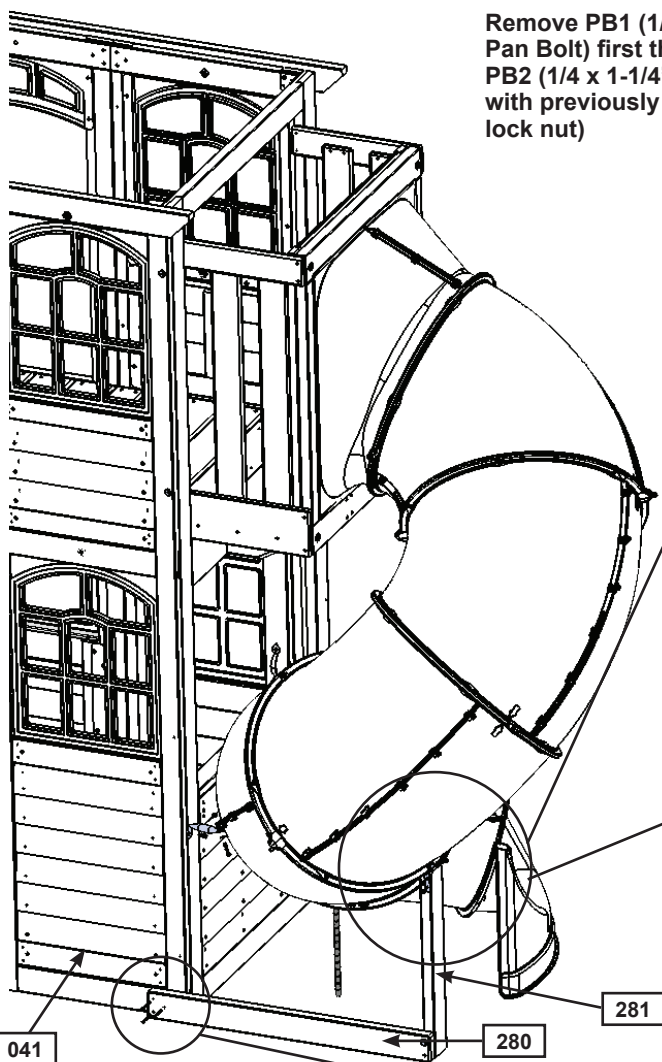

Fig. 30.2

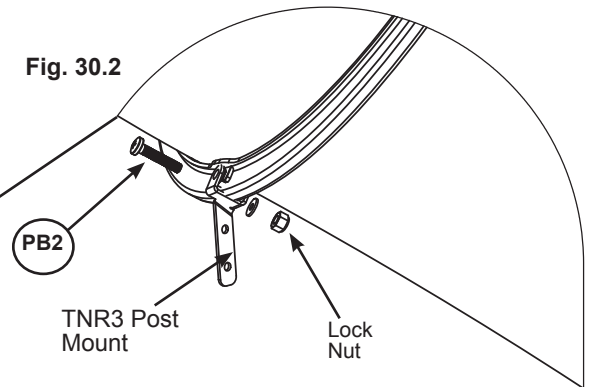

Fig. 30.3

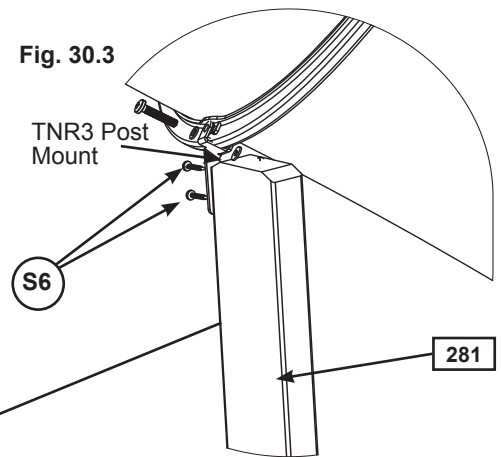
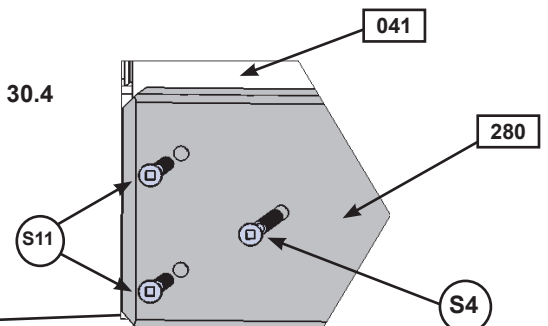

Fig. 30.4



### Hardware

- 1 x (PB2) 1/4 x 1-1/4" Pan Bolt  
1 - (1/4" lock nut - previously removed)
- 2 x (S6) #12 x 1" Pan Screw
- 1 x (S4) #8 x 3" Wood Screw
- 2 x (S11) #8 x 2" Wood Screw

### Other Parts

- 1 x TNR3 Post Mount

# Step 31: Attach TNR3 Slide Exit to Exit Elbow Assembly



**A:** Insert flange of Exit Elbow Assembly (slide elbow) into the slots on TNR3 Short Exit. (fig. 31.1)

**B:** Rotate Slide Exit and use Quadrex Driver as a guide pin so the holes are aligned and attach with 5 (PB1) 1/4 x 3/4" Pan Bolts (with lock nuts) starting with the bottom middle hole and working up each side. (fig. 31.2 and 31.3)

**C:** At this point make sure all the slide bolts are tight. *Use a 7/16" open end wrench to hold nut and then tighten bolt with Quadrex Driver on Clamp Rings.*

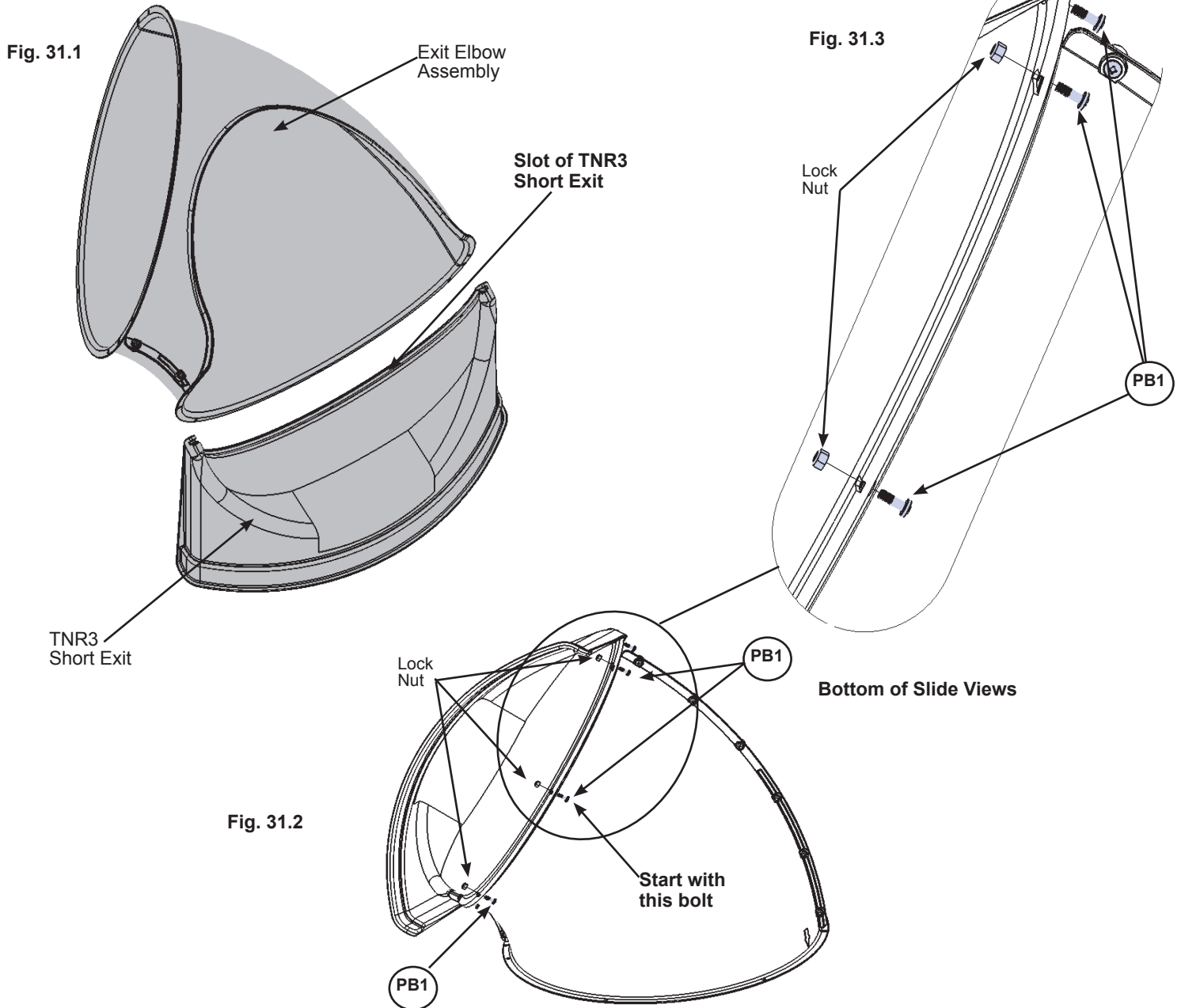

### Hardware

5 x (PB1) 1/4 x 3/4" Pan Bolt  
(1/4" lock nut)

### Other Parts

1 x TNR3 Short Exit

# Step 32: Attach Exit End Assembly to Fort



**Note:** When installing Pan Bolts make sure to look at holes so bolts go through the side with the round recess and the lock nuts go through the side with the hexagonal recess. Keep all bolts loose until further step.

**A:** Fit the Exit End Assembly to the last Elbow Assembly by lining up the arrows on each assembly. Notice the elbow orientation. (fig. 32.1)

**B:** Place 1 TNR2 Slide Clamp Ring to the top of the joined Assemblies, rotate counter clockwise 1 hole location then attach with 3 (PB1) 1/4 x 3/4" Pan Bolts (with lock nut) as shown in fig. 32.1.

**Use Quadrex Driver as a guide pin for each hole before inserting bolt.**

**C:** Attach 1 TNR2 Slide Clamp Ring to the bottom of the joined Assemblies using 3 (PB1) 1/4 x 3/4" Pan Bolts (with lock nut) as shown in fig. 32.2.

**D:** Connect the 2 TNR2 Slide Clamp Rings together in 2 spots using 1 (PB1) 1/4 x 3/4" Pan Bolt (with lock nut) per hole. Make sure seams and arrows line up and then tighten all bolts. (fig. 32.3).

Fig. 32.1 Top Slide Bolt Holes

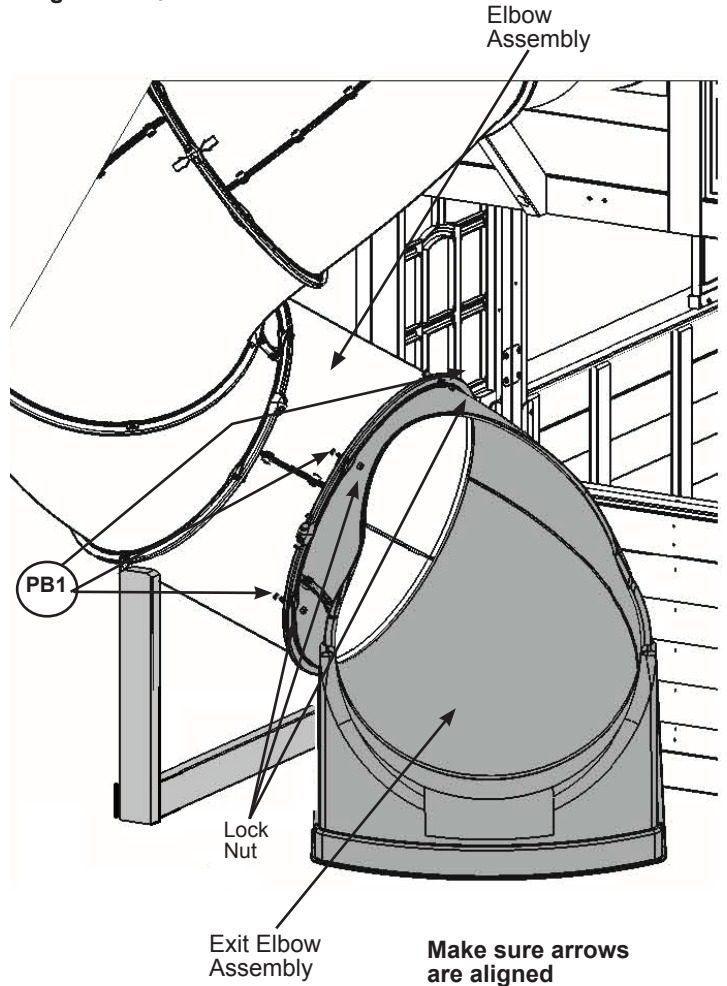

Fig. 32.2 Bottom Slide Bolt Holes

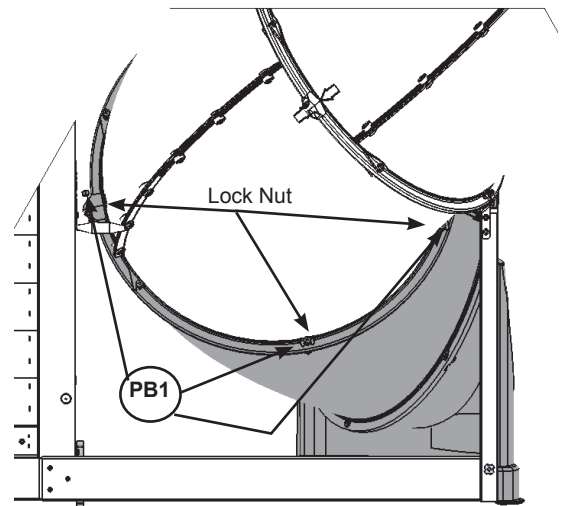
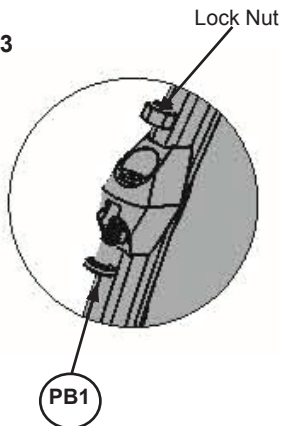

Fig. 32.3

After the clamp rings are attached to the elbows, fasten them end to end with two pan bolts and lock nuts



### Hardware

8 x (PB1) 1/4 x 3/4" Pan Bolt (1/4" lock nut)

### Other Parts

2 x TNR2 Slide Clamp Ring

## Step 33: Attach Ground Stake to TNR Upright

**A:** In the spot shown in fig. 33.1 drive 1 Rebar Ground Stake 13" into the ground against the (281) TNR Upright. Be careful not to hit the washer while hammering stake into the ground as this could cause the washer to break off.

**B:** Attach the ground stake to (280) Ground Brace just below the bolt head using 1 (S7) #12 x 2" Pan Screw as shown in fig. 33.2.

**C:** After driving stakes into the ground, check for sharp edges caused by the impact of the hammer. Smooth any sharp edges from impact area and touch up with outdoor paint.



**Warning! To prevent tipping and avoid potential injury, stakes must be driven 13" into ground. Digging or driving stakes can be dangerous if you do not check first for under-ground wiring, cables or gas lines.**

Fig. 33.1

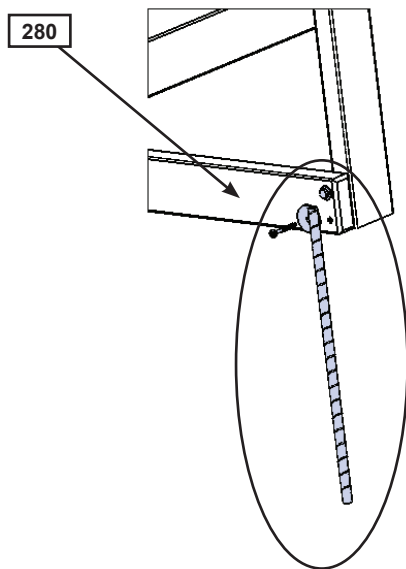
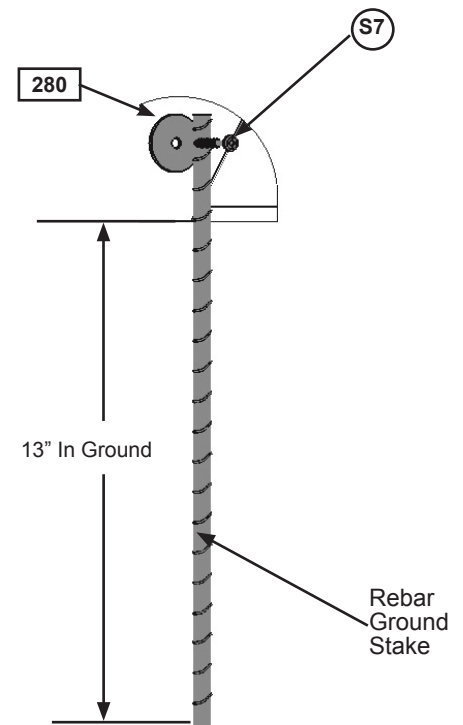

Fig. 33.2



### Hardware

1 x (S7) #12 x 2" Pan Screw

### Other Parts

1 x Rebar Ground Stake

## Step 34: Roof Rafter Assembly

**A:** Attach 1 (340) Roof Rafter to a second (340) Roof Rafter at peak using 1 (S4) #8 x 3" Wood Screw. Repeat this twice so there are 2 Roof Rafter Assemblies. (fig. 34.1)

Fig. 34.1

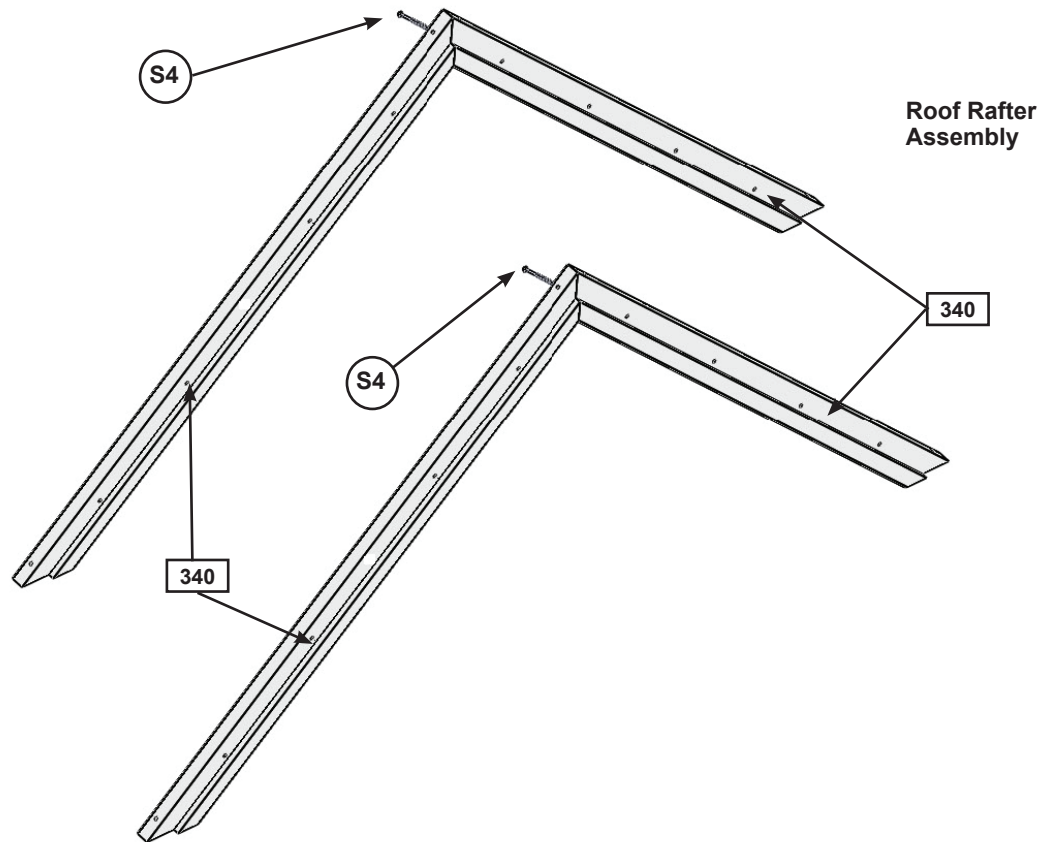

### Wood Parts

4 x 340 Roof Rafter 1-1/4 x 3 x 50-15/16"

### Hardware

2 x S4 #8 x 3" Wood Screw



# Step 35: Roof Assembly Part 1



**A:** Place (350) Roof Panel A against (351) Roof Panel B so the tops form a peak then tight to the inside edge of the outside slats attach 1 Narrow Angle Bracket per slat with 2 (S0) #8 x 7/8" Truss Screws per bracket. (fig. 35.1, 35.2 and 35.3)

**B:** Attach 2 more Narrow Angle Brackets on the middle slats so they are centred on the slat with 2 (S0) #8 x 7/8" Truss Screws per bracket. (fig. 35.1 and 35.3)

Fig. 35.1

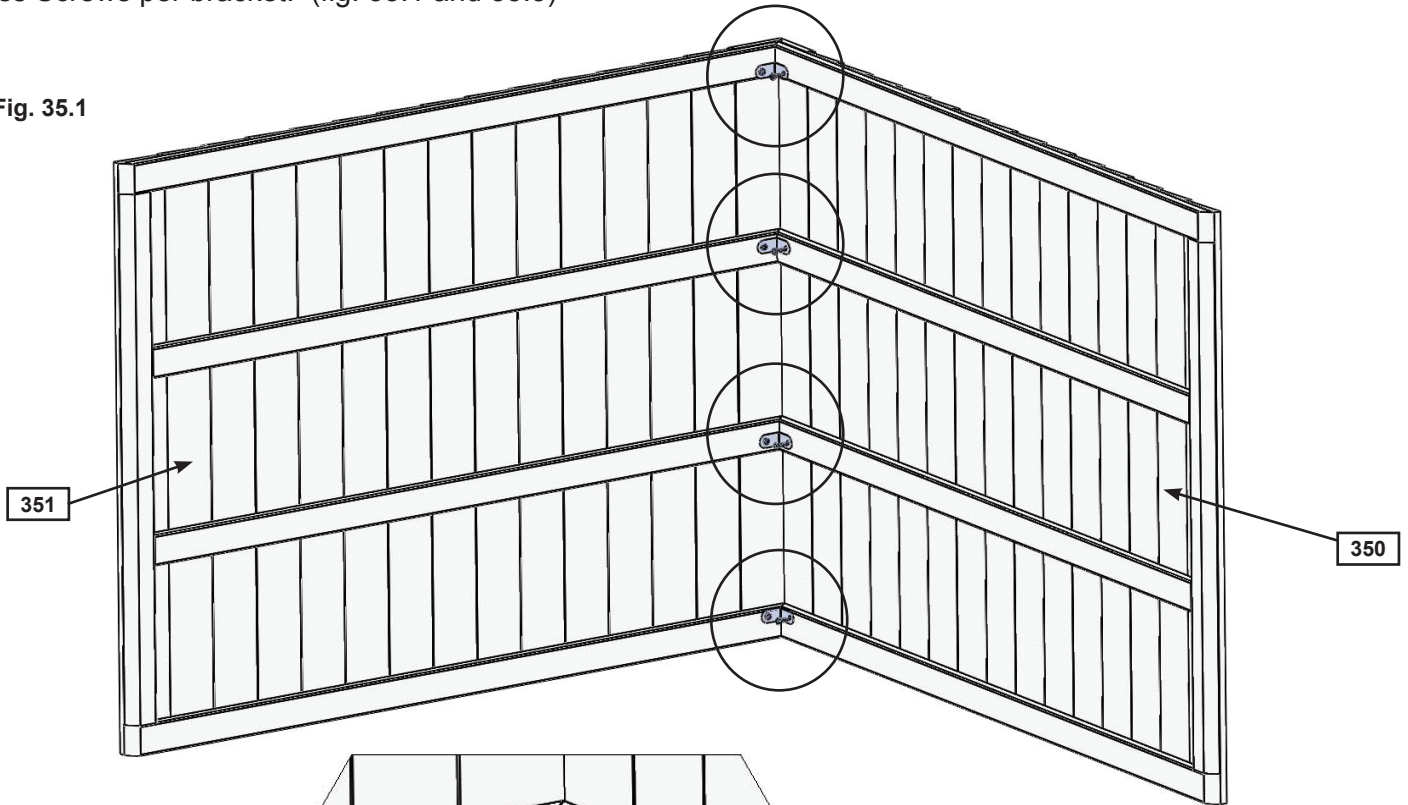

Fig. 35.3

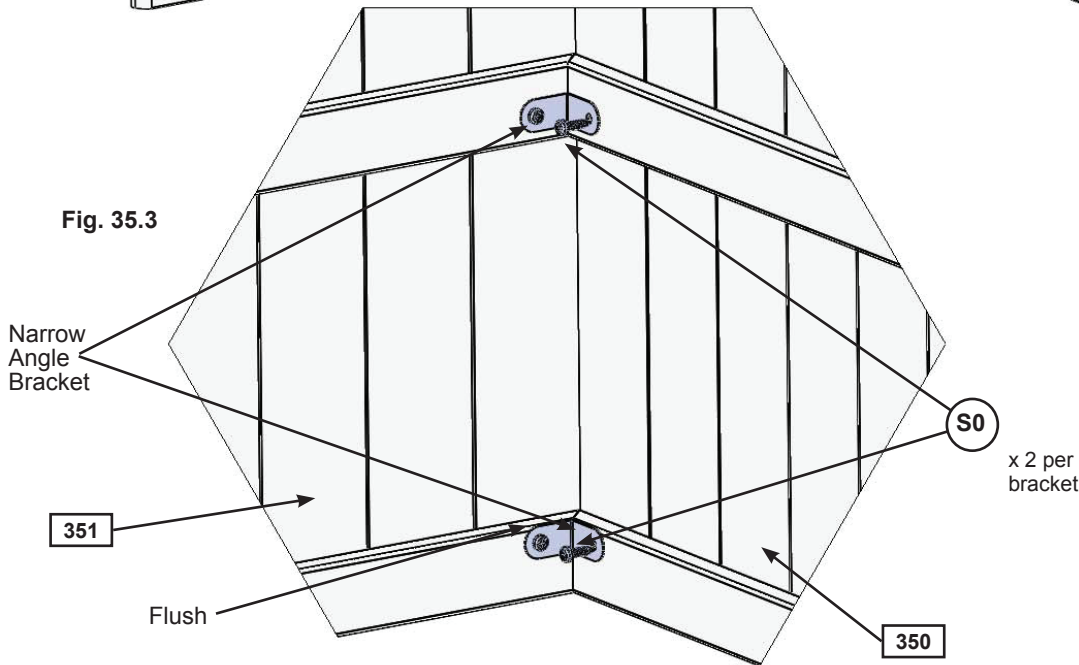
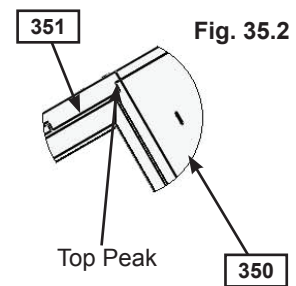

Fig. 35.2



### Wood Parts

- 1 x 350 Roof Panel A 1-1/4 x 39 x 50-3/16"
- 1 x 351 Roof Panel B 1-1/4 x 39 x 50-7/16"

### Hardware

- 8 x S0 #8 x 7/8" Truss Screw

### Other Parts

- 4 x Narrow Angle Bracket

## Step 35: Roof Assembly Part 2

**C:** Place 1 Roof Rafter Assembly against one side so the peaks meet and the ends of the roof supports are flush with the ends of the roof panels. Attach with 8 (S11) #8 x 2" Wood Screws. (fig. 35.4)

**D:** Attach the second Roof Rafter Assembly on the opposite side, peaks to meet and ends are flush with 8 (S11) #8 x 2" Wood Screws. (fig. 35.4)

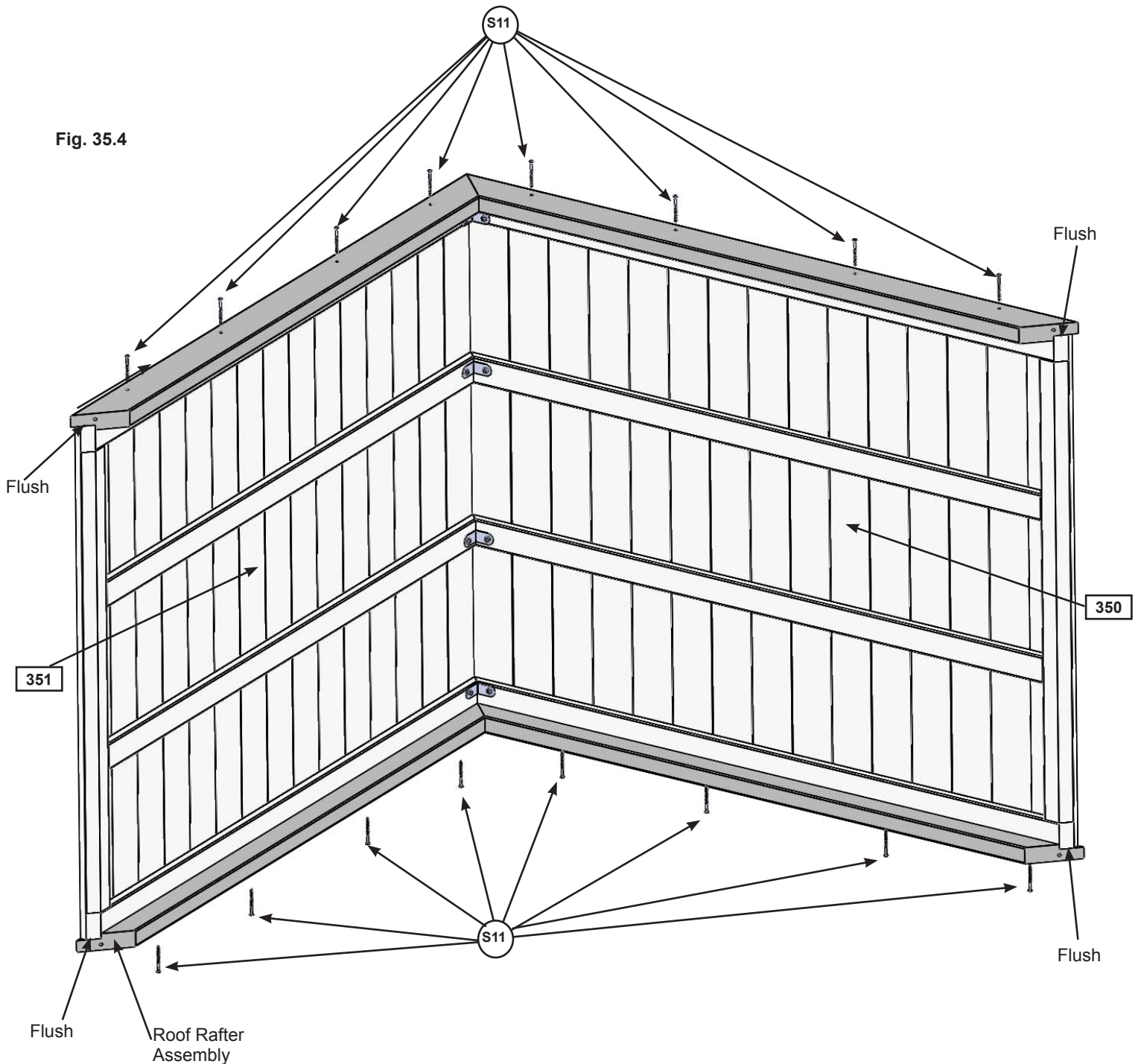

### Hardware

16 x (S11) #8 x 2" Wood Screw

# Step 36: Back Gable Assembly Part 1



**A:** Measure from the outside edges of each (340) Roof Rafter on the Back side of the the Roof Assembly so the distance is 72". (fig. 36.1)

**B:** Maintain the 72" then tight to each rafter attach (360) Back Gable Support with 1 (S3) #8 x 2-1/2" Wood Screw and 1 (S11) #8 x 2" Wood Screw per side. (fig. 36.1 and 36.2)

Fig. 36.1

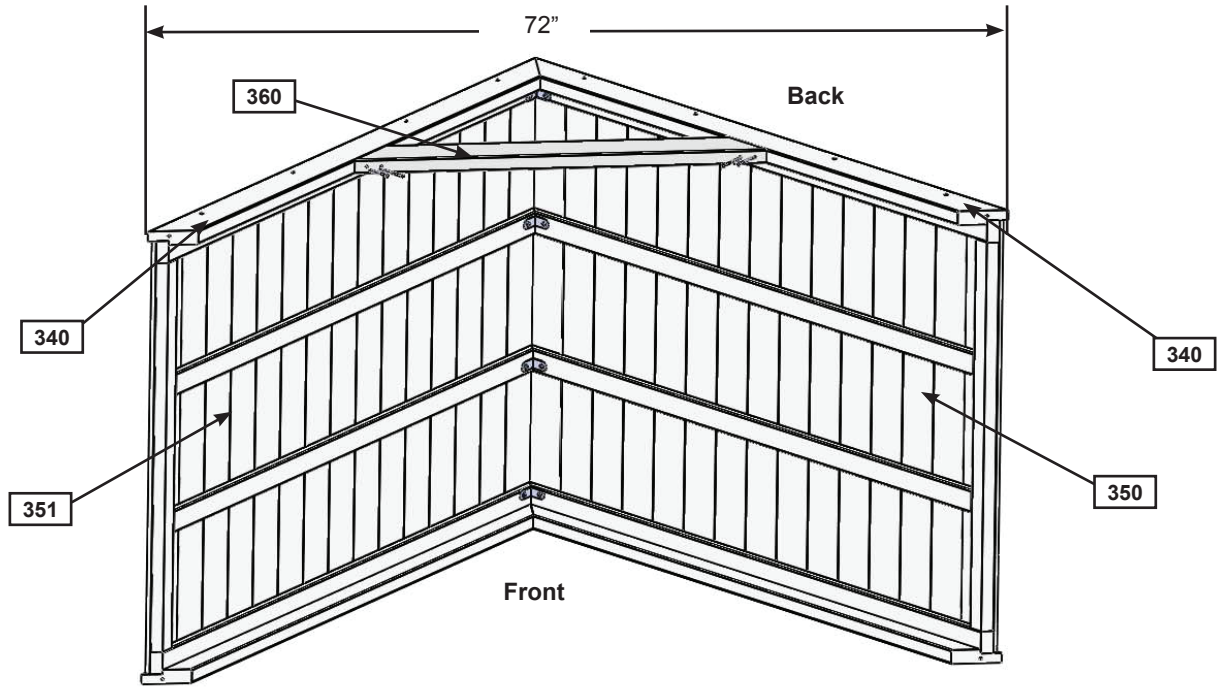
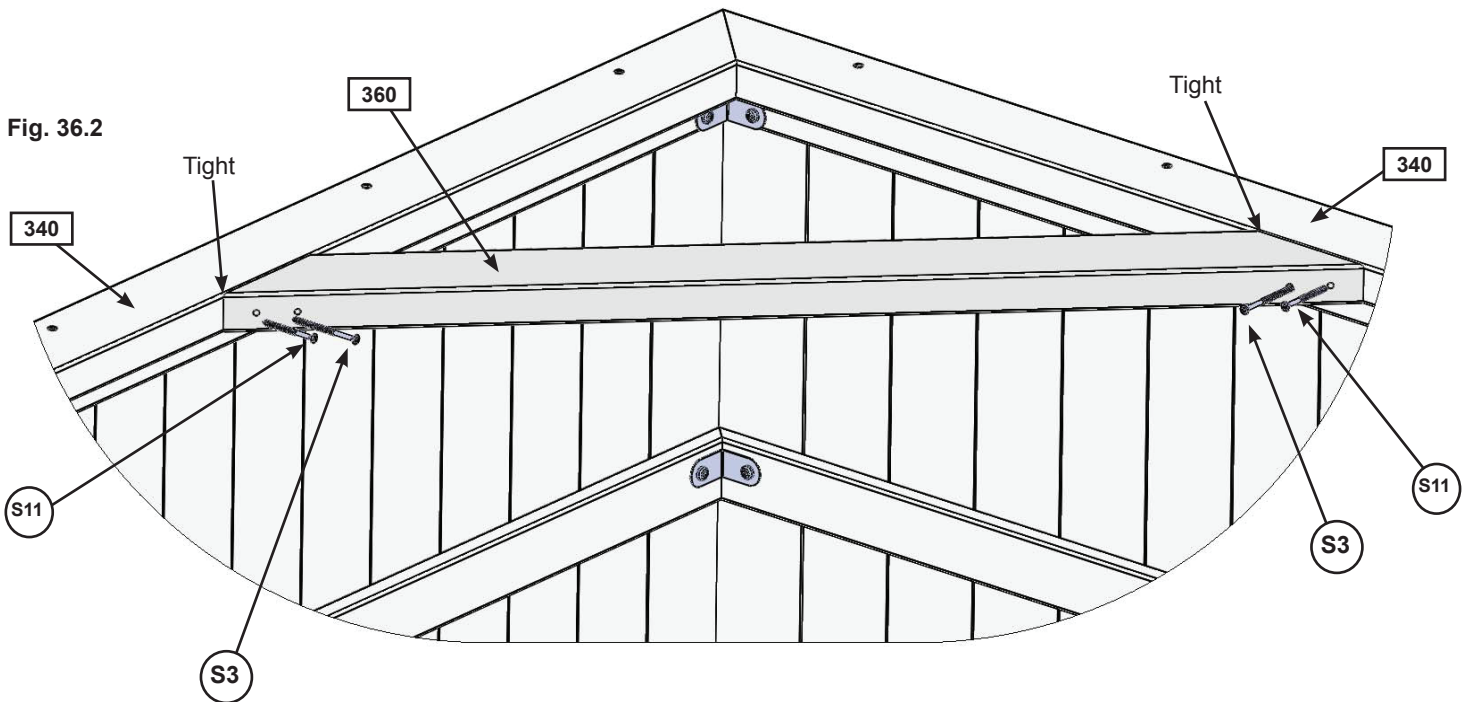

Fig. 36.2



### Wood Parts

1 x **360** Back Gable Support 1-1/4 x 3 x 34-1/2"

### Hardware

2 x **S3** #8 x 2-1/2" Wood Screw

2 x **S11** #8 x 2" Wood Screw



# Step 36: Back Gable Assembly Part 2

**C:** Turn the Roof Assembly over so the Back side is on the bottom. Place (361) BK Centre Gable on top of (360) Back Gable Support and on both (340) Roof Rafters, tight to the peak, then attach with 2 (S20) #8 x 1-3/8" Wood Screws. (fig. 36.3, 36.4 and 36.5)

**D:** Place (362) Starburst Centre centred under (361) BK Centre Gable, tight to the top of (360) Back Gable Support then attach (361) BK Centre Gable to (362) Starburst Centre with 1 (S20) #8 x 1-3/8" Wood Screw. (fig. 36.3, 36.4 and 36.5)

**E:** Place 1 (363) Sunburst Side tight to each side of (361) BK Centre Gable and to the top of (360) Back Gable Support then attach to (362) Starburst Centre with 1 (S20) #8 x 1-3/8" Wood Screw per board. (fig. 36.3, 36.4 and 36.5)

**F:** Attach (361) BK Centre Gable and both (363) Sunburst Sides to the (340) Roof Rafters with 2 (S20) #8 x 1-3/8" Wood Screw per board. (fig. 36.4)

**Fig. 36.3**  
Inside View

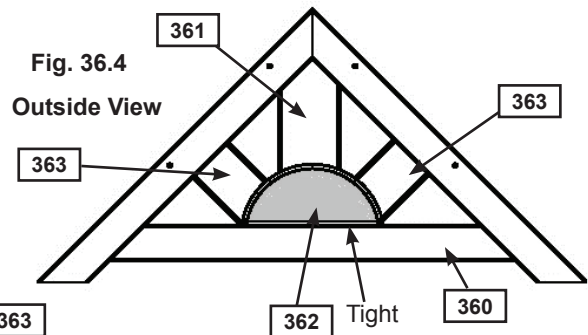
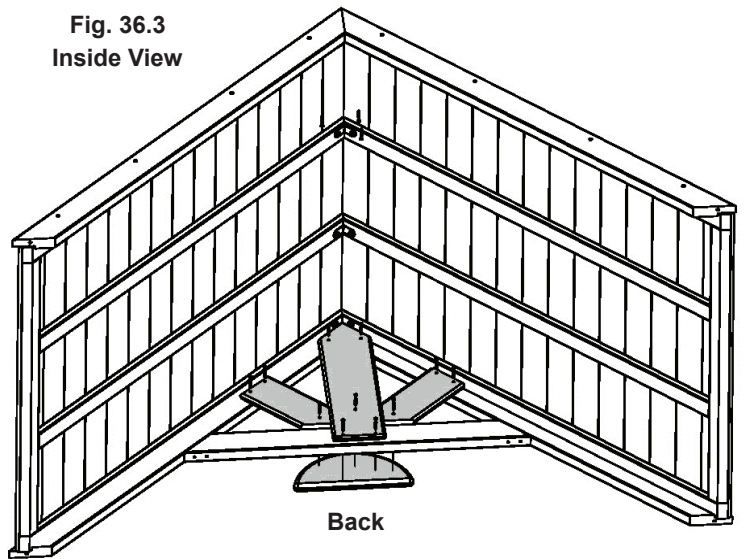

**Fig. 36.5**  
Inside View

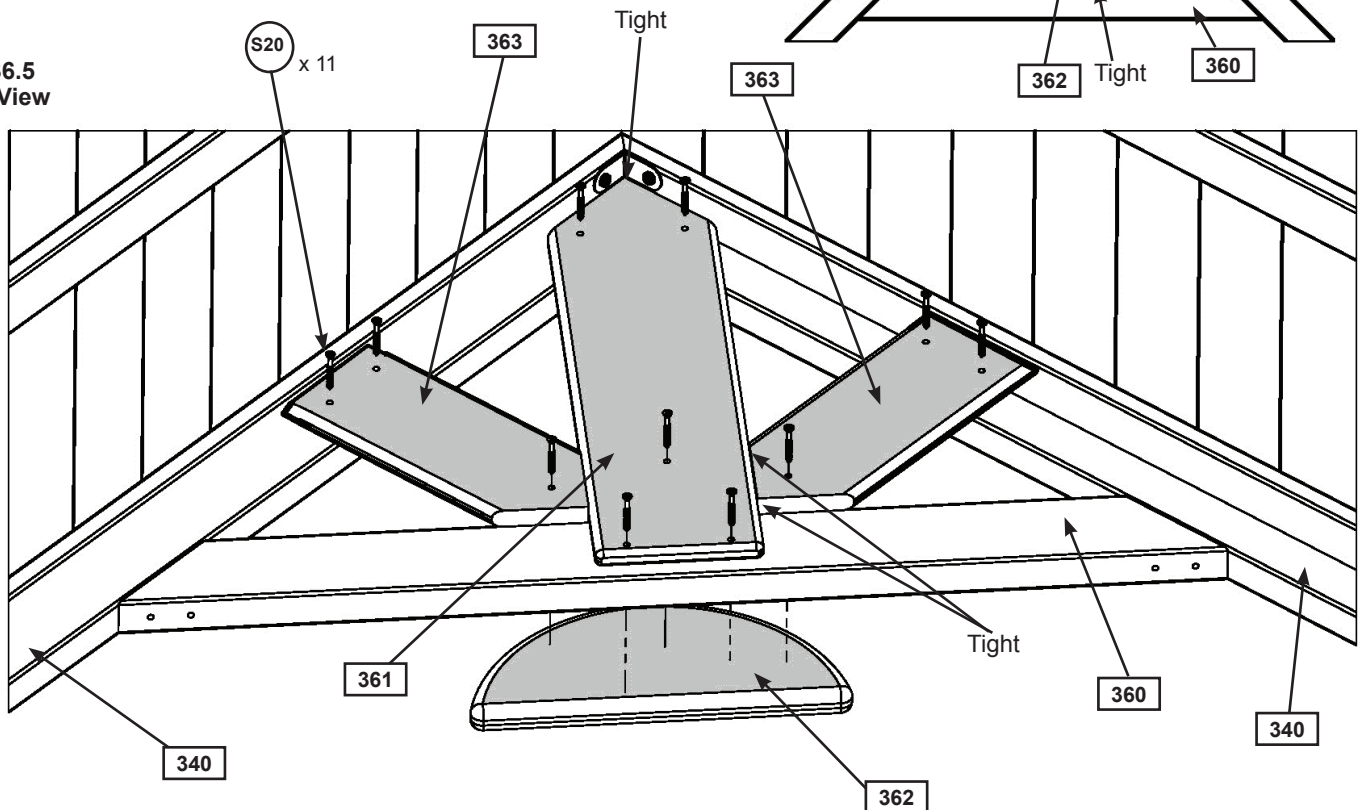

### Wood Parts

- 1 x **361** BK Centre Gable 1 x 6 x 19"
- 1 x **362** Starburst Centre 5/4 x 6 x 12"
- 2 x **363** Sunburst Side 1 x 5 x 10"

### Hardware

- 11 x **(S20)** #8 x 1-3/8" Wood Screw

# Step 37: Front Gable Assembly



**A:** Measure from the outside edges of each (340) Roof Rafter on the Front side of the Roof Assembly so the distance is 72". (fig. 37.1)

**B:** Maintain the 72" then tight to each rafter attach (370) Mid Gable Support with 1 (S3) #8 x 2-1/2" Wood Screw and 1 (S11) #8 x 2" Wood Screw per side. (fig. 37.1 and 37.2)

Fig. 37.1

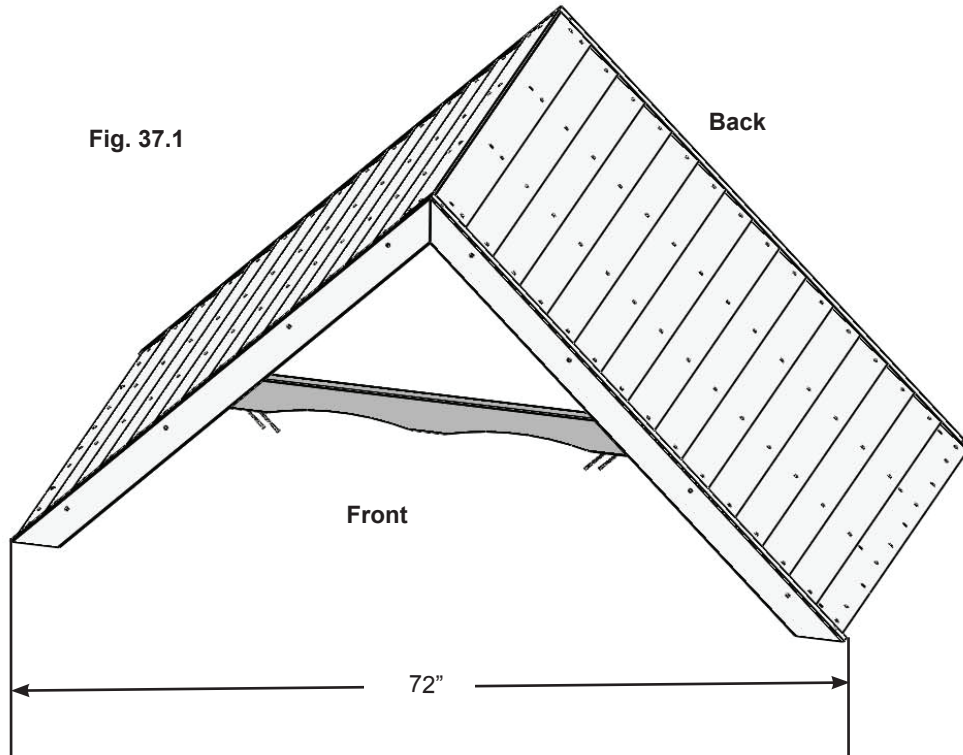
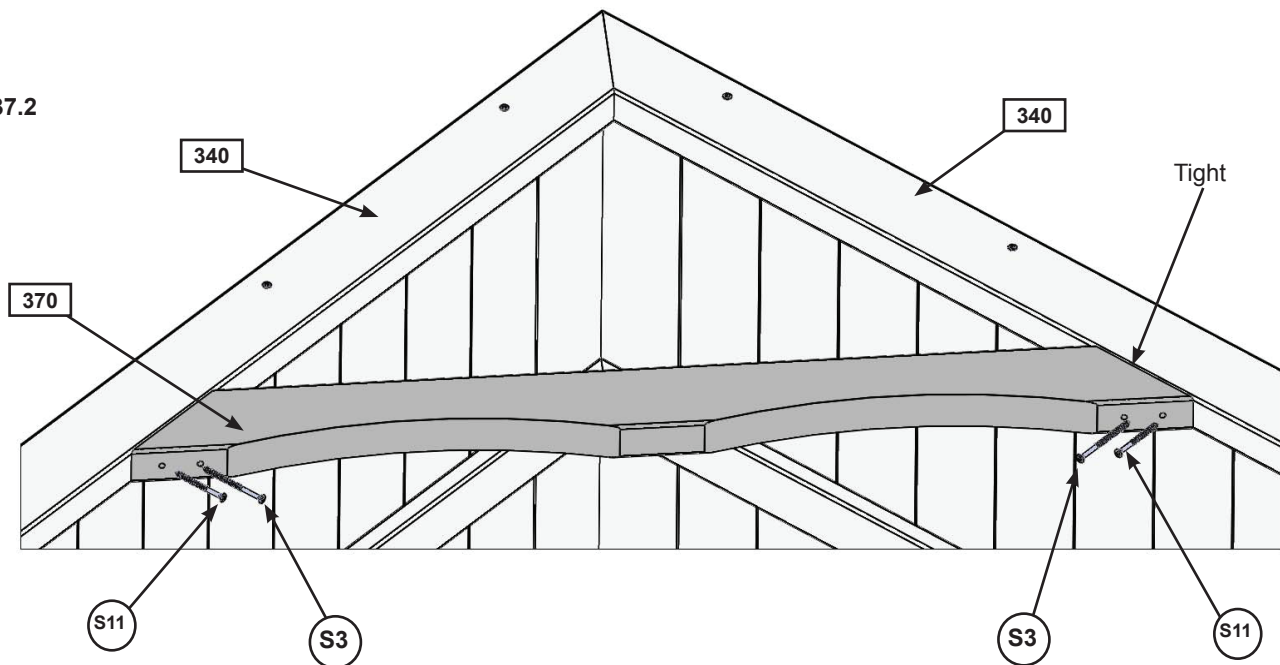

Fig. 37.2



### Wood Parts

1 x **370** Mid Gable Support 1-1/4 x 3 x 34-1/2"

### Hardware

2 x **S3** #8 x 2-1/2" Wood Screw

2 x **S11** #8 x 2" Wood Screw



# Step 38: Attach Roof Assembly to Fort Part 1

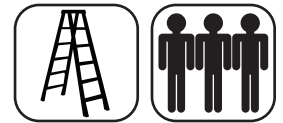

**A:** With 2 people on the ground and at least 1 person in the fort, lift the Roof Assembly up and over the Front side of the fort. Guide the Roof Assembly onto the fort so all four (340) Roof Rafter sit flush to the outside edges of (062) Roof Supports. Notice which way the openings face. (fig. 38.1)

**B:** Attach (340) Roof Rafter to (062) Roof Supports with 1 (S3) #8 x 2-1/2" Wood Screw per corner. (fig. 38.1 and 38.2)

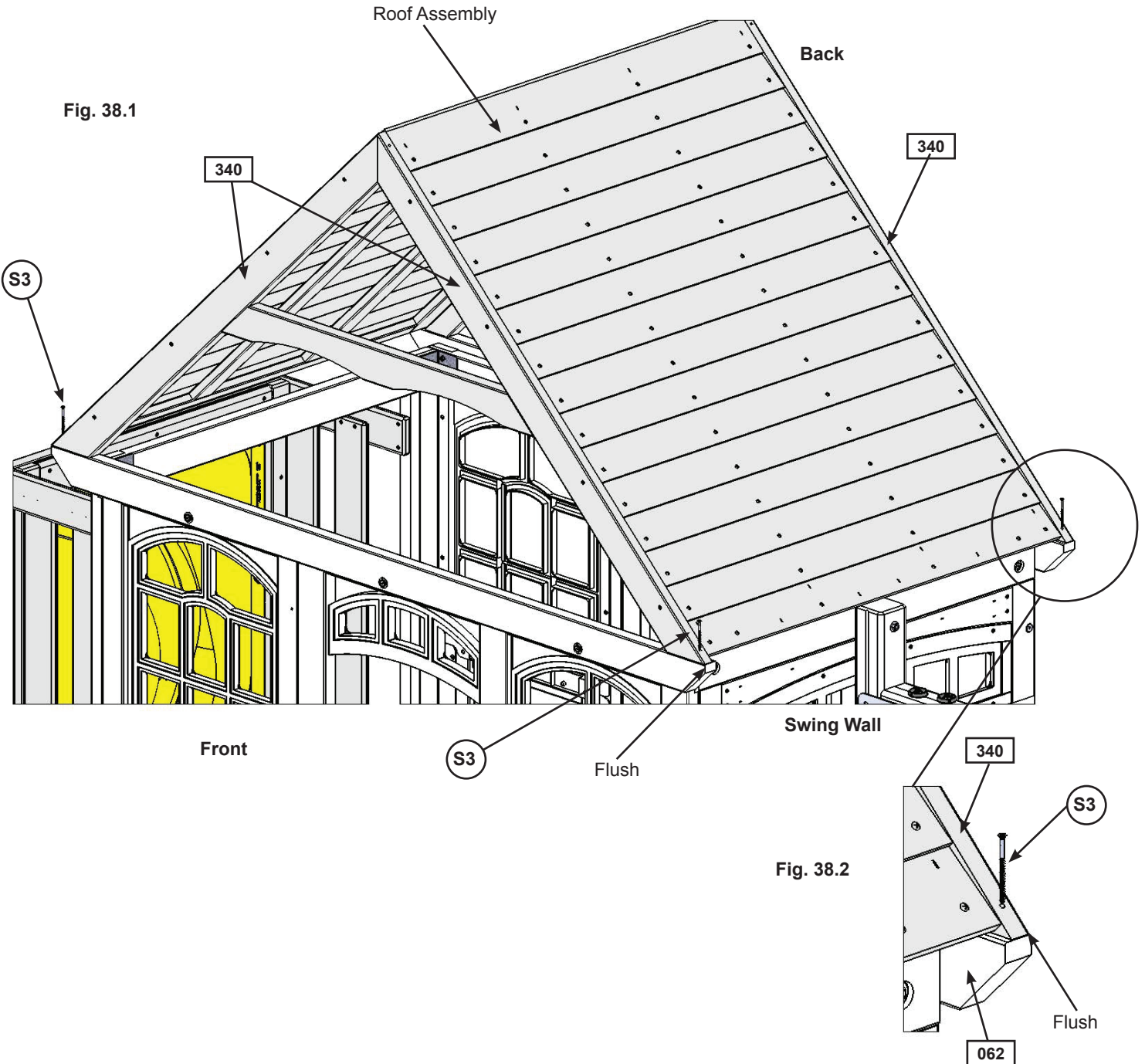

## Hardware

4 x S3 #8 x 2-1/2" Wood Screw

# Step 38: Attach Roof Assembly to Fort Part 2



**C:** On the Back of the assembly attach each (340) Roof Rafter to (062) Roof Support with 1 Small Jamb Mount per side using 2 (S0) #8 x 7/8" Truss Screws per mount. (fig. 38.3 and 38.4)

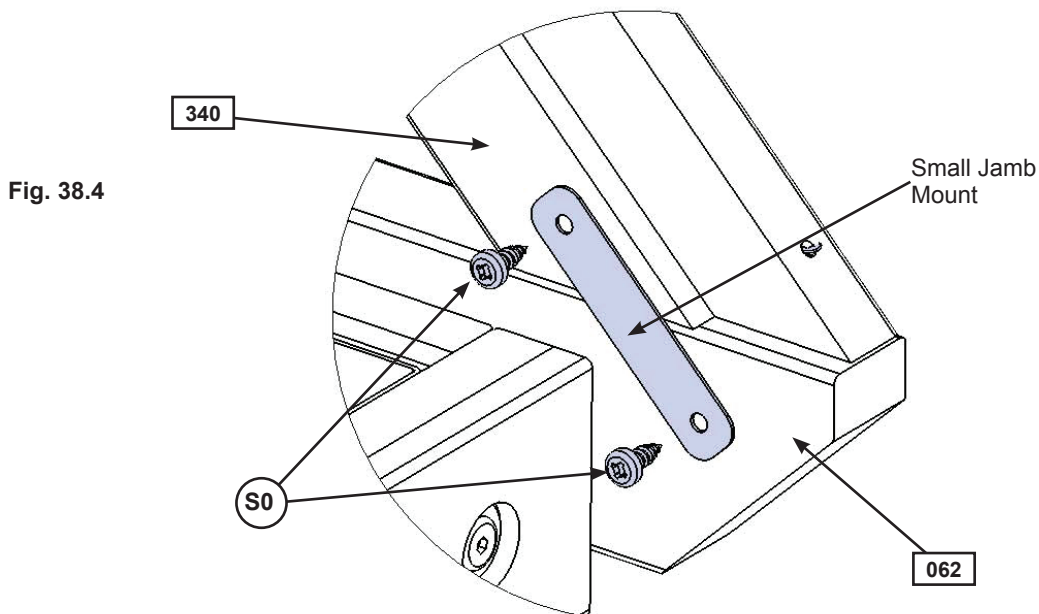
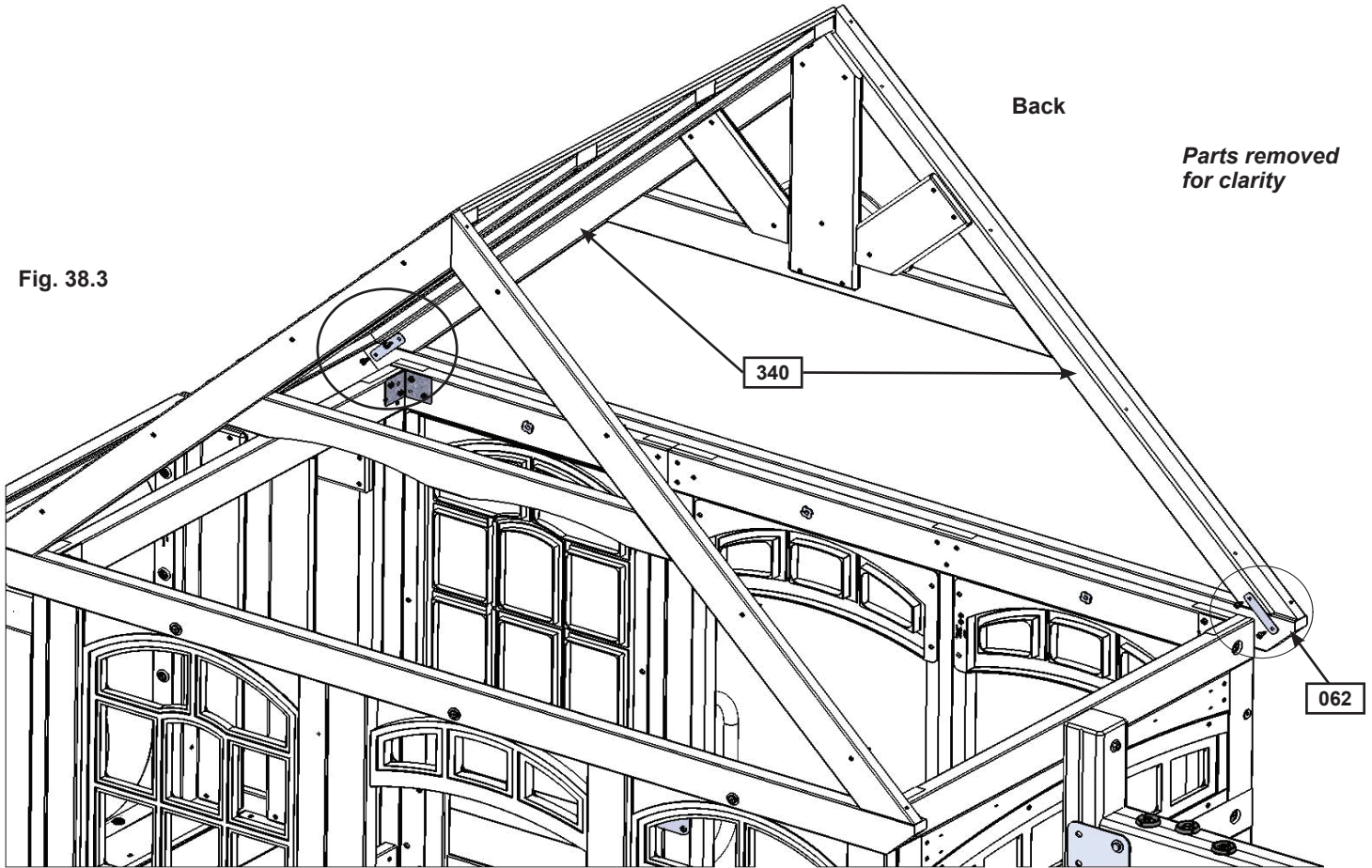

### Hardware

4 x (S0) #8 x 7/8" Truss Screw

### Other Parts

2 x Small Jamb Mount

# Step 39: Front Roof Assembly Part 1



**A:** On the Front, from inside the assembly, measure 36" from the end of (062) Roof Support. Place (390) FR Centre Gable on top of (051) Front Wall Panel so the middle is at the 36" mark. Attach to (062) Roof Support, (370) Mid Gable Support and (340) Roof Rafters with 5 (S20) #8 x 1-3/8" Wood Screws. (fig. 39.1 and 39.2)

**B:** From the outside of the assembly place (362) Starburst Centre on top of (370) Mid Gable support then attach (390) FR Centre Gable to (362) Starburst Centre with 1 (S20) #8 x 1-3/8" Wood Screw. (fig. 39.1 and 39.2)

**C:** Place 1 (363) Sunburst Side tight to each side of (390) FR Centre Gable and tight to each (340) Roof Rafter then attach to (362) Starburst Centre and (340) Roof Rafters with 3 (S20) #8 x 1-3/8" Wood Screws per board. (fig. 39.1 and 39.2)

Fig. 39.1  
Outside View

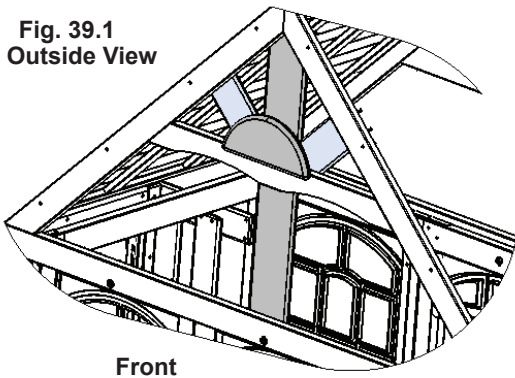

Parts removed  
for clarity

Fig. 39.2  
Inside View

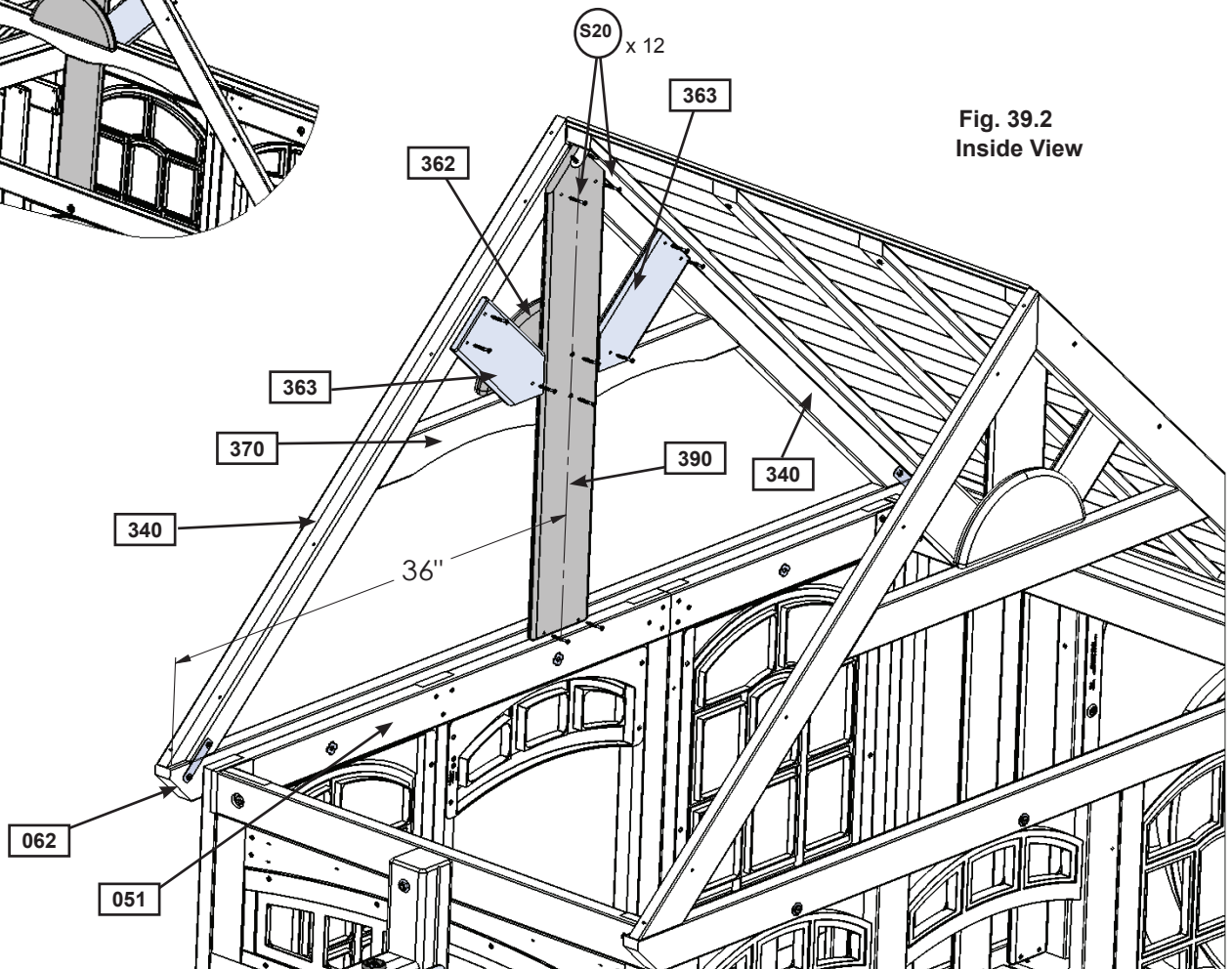

### Wood Parts

- 1 x 390 FR Centre Gable 1 x 6 x 34-15/16"
- 1 x 362 Starburst Centre 5/4 x 6 x 12"
- 2 x 363 Sunburst Side 1 x 5 x 10"

### Hardware

- 12 x S20 #8 x 1-3/8" Wood Screw



# Step 39: Front Roof Assembly Part 2



**D:** From inside the assembly measure 10" from each side of the (390) FR Centre Gable then place 1 (391) End Gable A on top of (051) Front Wall Panel and (042) Narrow Front Panel at each 10" mark and attach to (062) Roof Support, (370) Mid Gable Support and (340) Roof Rafters with 4 (S20) #8 x 1-3/8" Wood Screws per board. (fig. 39.3)

**E:** On each side beside (391) End Gable A, evenly space 1 (392) End Gable D then 1 (393) End Gable B and lastly 1 (394) End Gable C. Attach each board to (062) Roof Support, (340) Roof Rafters and (051) Front Wall Panel or (042) Narrow Front Panel with 4 (S20) #8 x 1-3/8" Wood Screws per board. (fig. 39.3)

Fig. 39.3  
Inside View

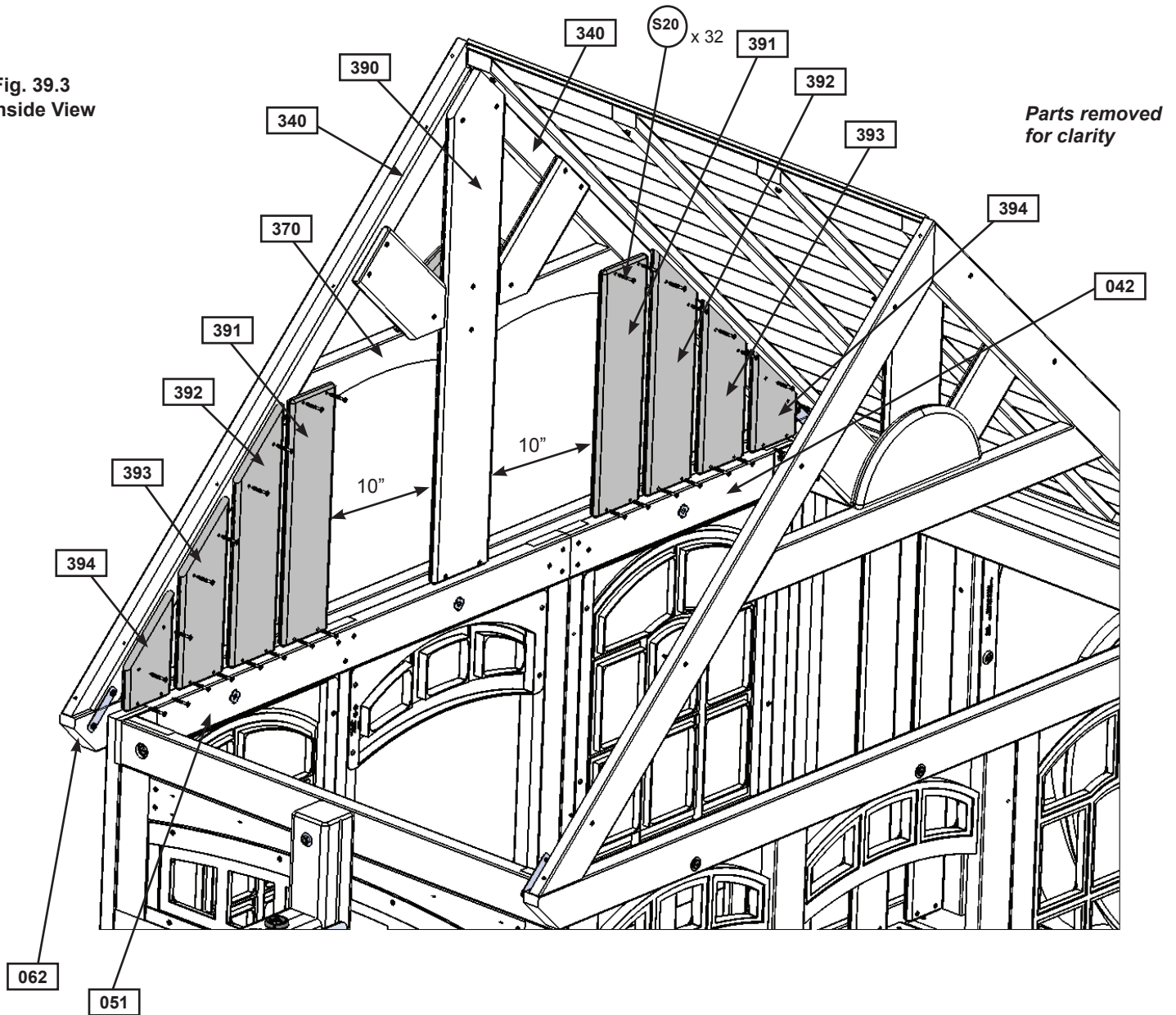

### Wood Parts

- 2 x 391 End Gable A 1 x 5 x 17-1/8"
- 2 x 392 End Gable D 1 x 5 x 17-1/8"
- 2 x 393 End Gable B 1 x 5 x 12-1/8"
- 2 x 394 End Gable C 1 x 5 x 7-1/8"

### Hardware

- 32 x S20 #8 x 1-3/8" Wood Screw

# Step 39: Front Roof Assembly Part 3



F: From outside the assembly place a 2 x 2 Panel Window in each opening and attach to (390) FR Centre Gable and each (391) End Gable A with 6 (S33) #8 x 1" Wood Screws per window. (fig. 39.4)

Fig. 39.4  
Outside View

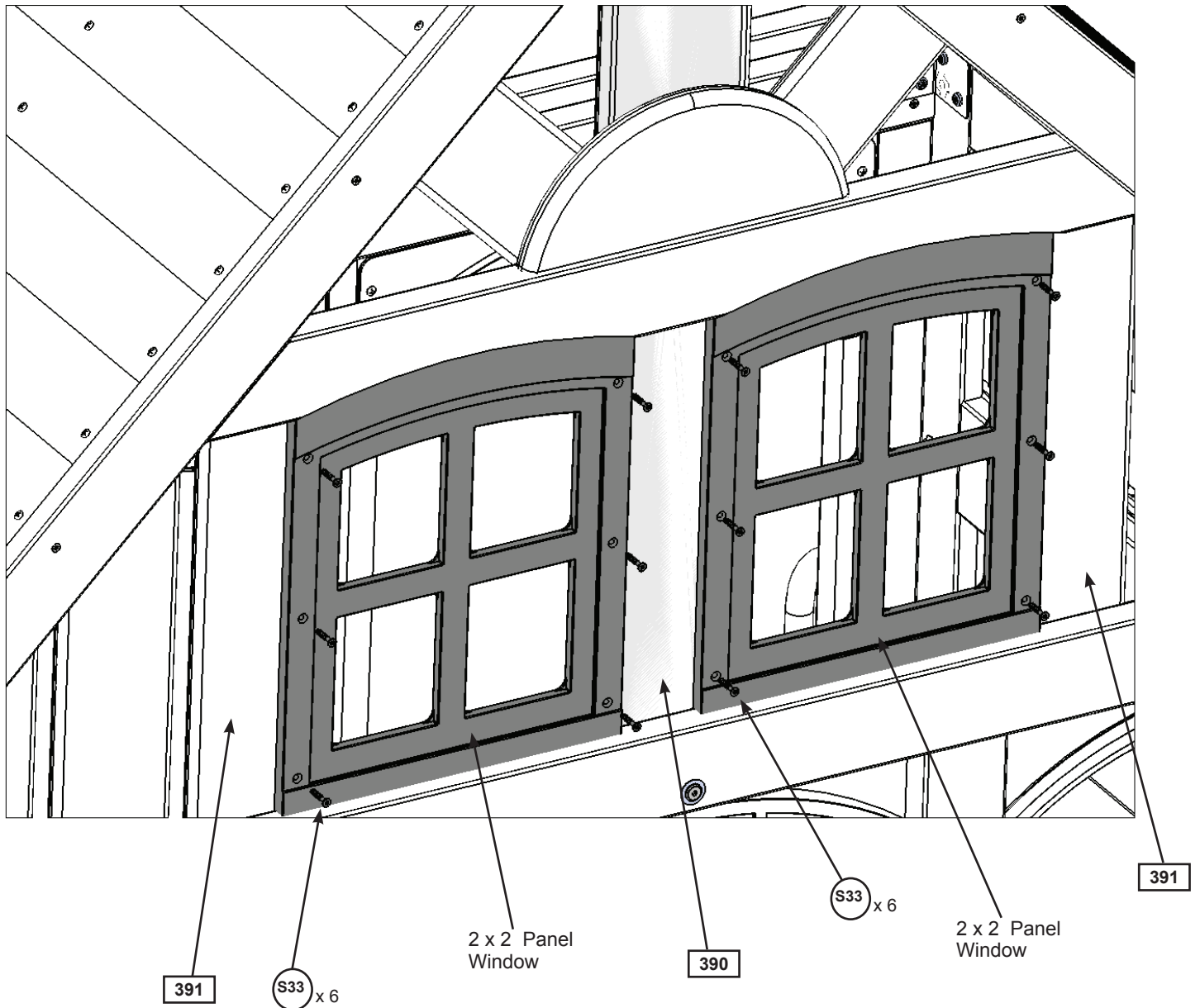

### Hardware

12 x  #8 x 1" Wood Screw

### Other Parts

2 - 2 x 2 Panel Window



# Step 40: Attach Swings

**A:** Using 1 Threaded Quick Link per chain, join 1 Long Swing Chain to each side of the Swing Belt Seat. Make sure to close the Threaded Quick Link tightly using an adjustable wrench. (fig. 40.1 and 40.2).

**B:** Using 1 Threaded Clip per chain, join the Short Swing Chain to the Acro Bar. Using another Threaded Clip, join the Acro Handle to the Acro Bar. Make sure to close the Threaded Clip tightly using an adjustable wrench. (fig. 40.2 and 40.3)

**C:** Attach the other end of the swing chains to the Spring Loaded Quick Links attached to the Heavy Duty Swing Hangers. (fig. 40.1)

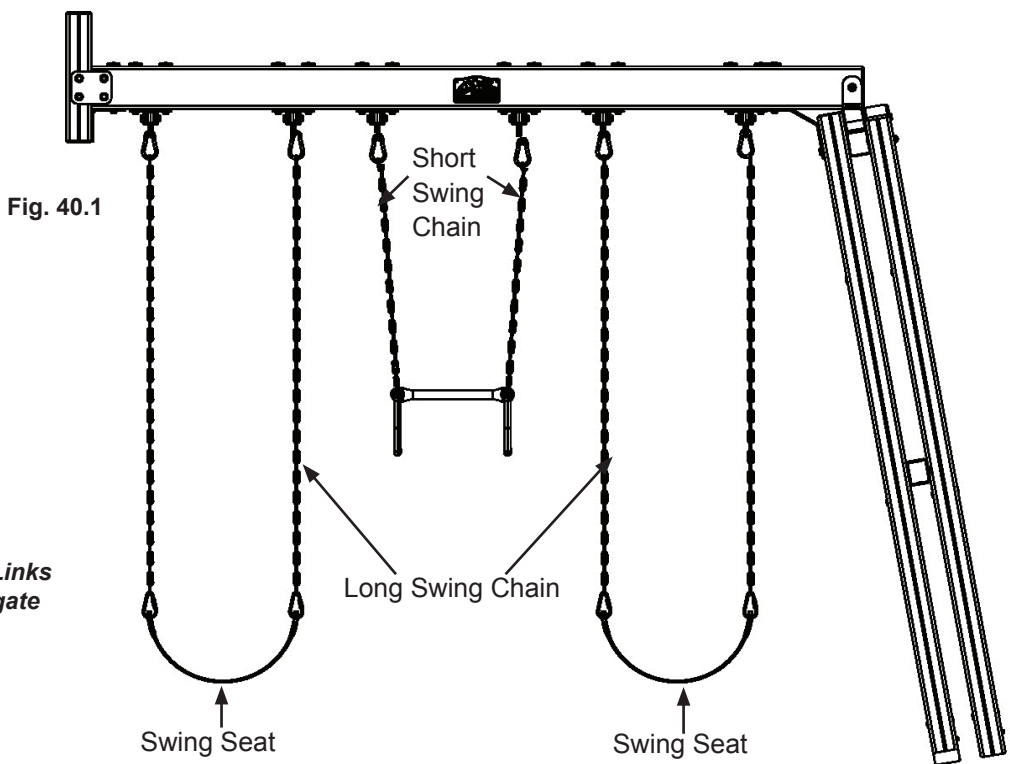

**Caution:** Threaded Quick Links must be installed with the gate completely down covering the threads and tighten as instructed. (fig. 40.2)

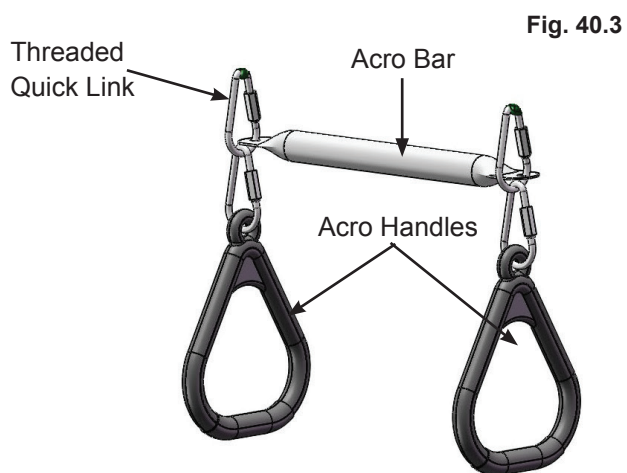
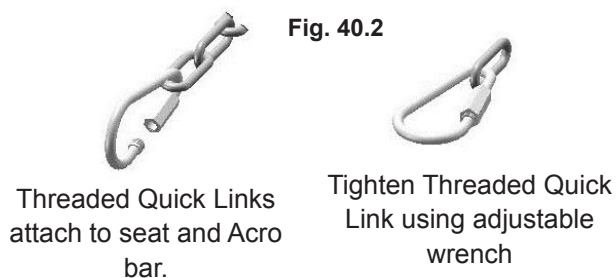

### Other Parts

- 1 x Acro Bar
- 2 x Acro Handle
- 2 x Swing Belt Seat
- 2 x Short Swing Chain
- 4 x Long Swing Chain
- 8 x Threaded Quick Link

# Step 41: Attach Telescope



**A:** On the front, outer corner of the Crowsnest pre-drill with a 1/8" drill bit then attach Telescope to (200) Crowsnest Top and (212) Crowsnest Side with 2 (S11) #8 x 2" Wood Screws. (fig. 41.1 and 41.2)

Fig. 41.2

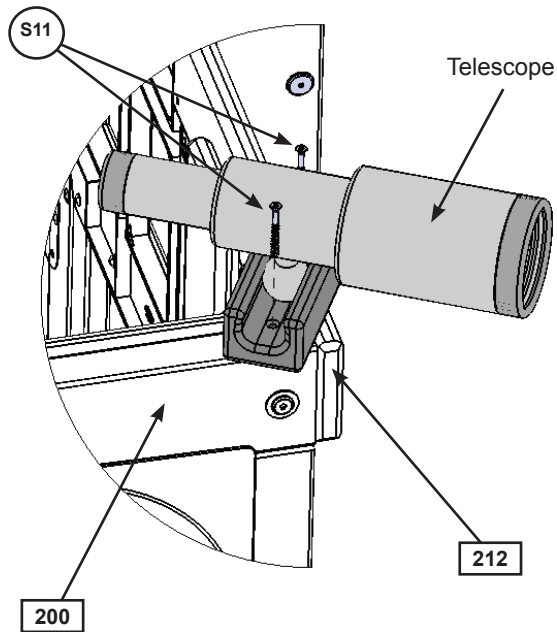
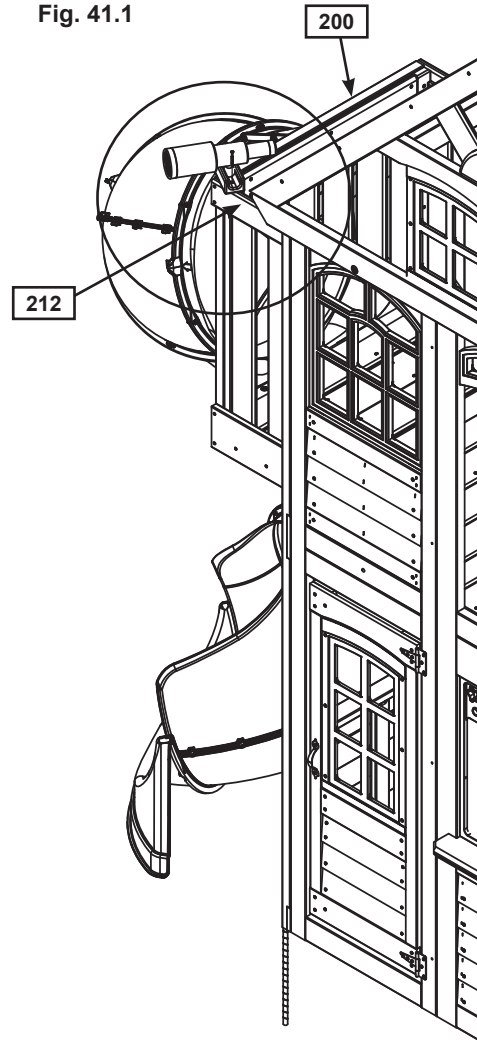

Fig. 41.1



### Hardware

2 x (S11) #8 x 2" Wood Screw

### Other Parts

1 x Telescope

# Step 42: Attach Steering Wheel

**A:** On the front upright of (050) SW Wall Panel attach Steering Wheel with 1 (WB10) 5/16 x 2-5/8" Wafer Bolt (with flat washer x 2 and lock nut). The bolt is attached from the outside of the assembly. (fig. 42.1 and 42.2)

Fig. 42.1

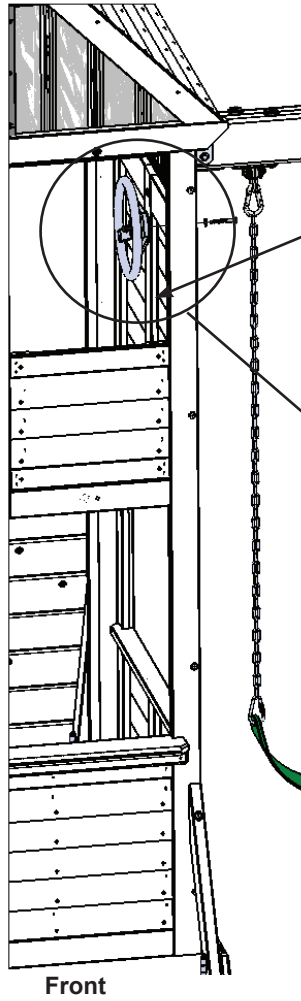

Window removed for clarity

Fig. 42.2  
Inside View

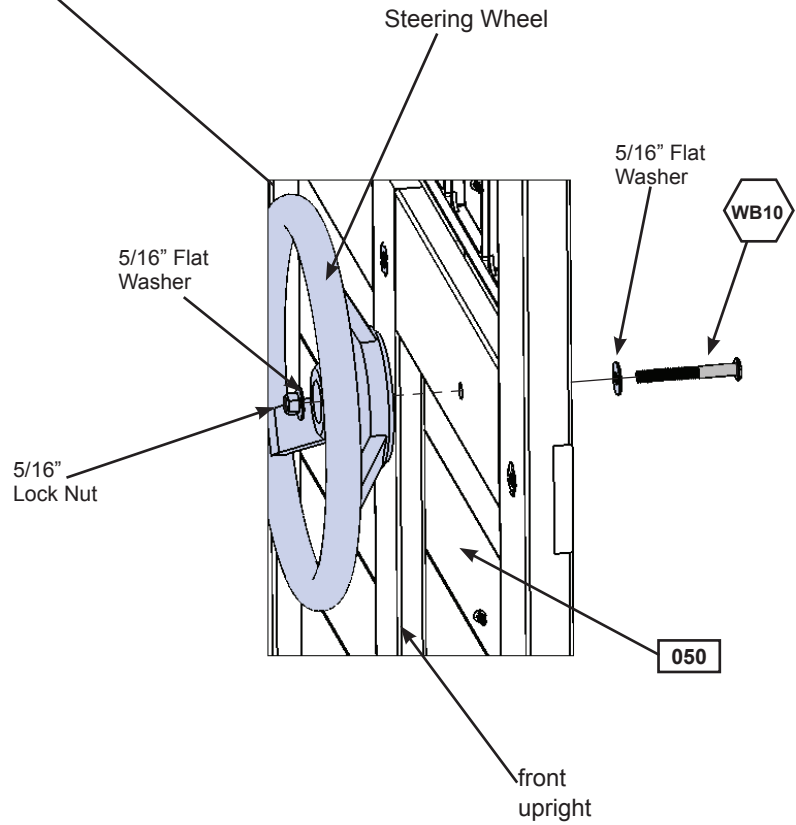

**Hardware**

1 x  5/16 x 2-5/8" Wafer Bolt  
(5/16" flat washer x 2, 5/16" lock nut)

**Other Parts**

1 x Steering Wheel

## Step 43: Attach Flower Boxes

**A:** On the front of the assembly place 1 Flower Box under each window and attach to (051) Front Wall Panel and (042) Narrow Front Panel with 2 (S13) #6 x 5/8" Pan Screws per Flower Box. (fig. 43.1 and 43.2)

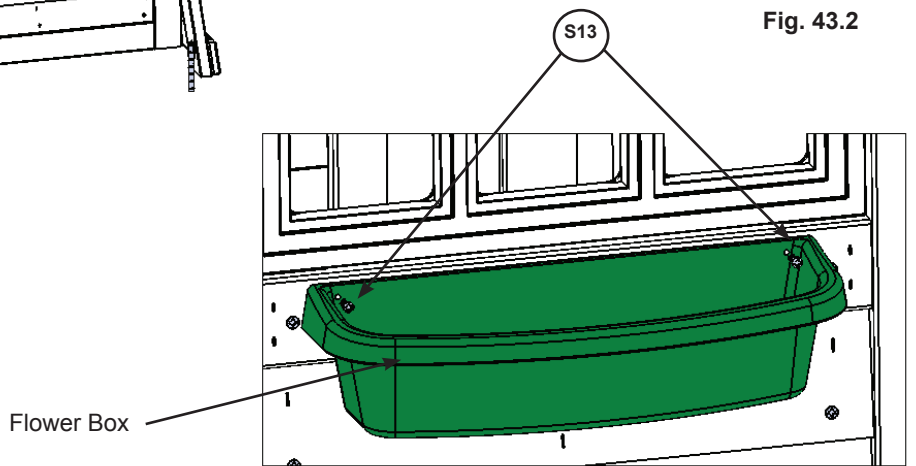

### Hardware

4 x (S13) #6 x 5/8" Pan Screw

### Other Parts

2 x Flower Box

# Step 44: Attach Clock Assembly



**A:** On the front of the assembly measure 3-1/4" up from the bottom of the centre board in (042) Narrow Front Panel then place the Gable Clock Assembly at the marked location centred under the Flower Box then attach with 4 (S10) #8 x 1" Pan Screws. Make sure the top screw connects to the block at the back of (042) Narrow Front Panel. (fig. 44.1, 44.2 and 44.3)



Fig. 44.1

042

Flower Box

Gable Clock Assembly

Centre Board

Fig. 44.2  
Inside View

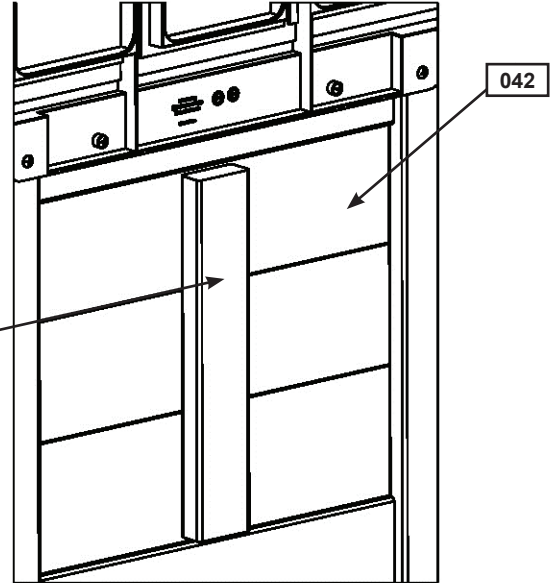

042

Top screw must connect to this board.

Fig. 44.3  
Outside View

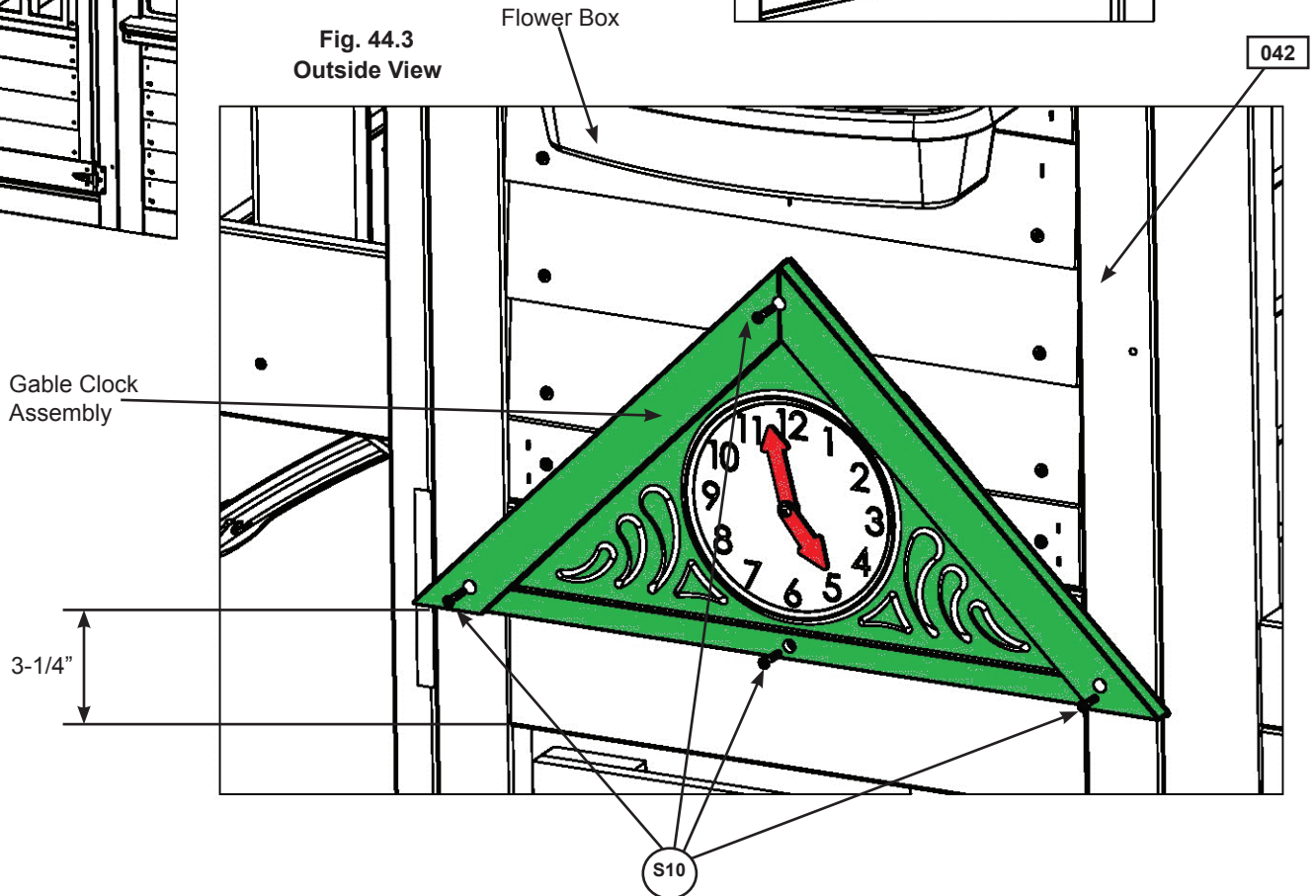

Gable Clock Assembly

3-1/4"

S10

### Hardware

4 x S10 #8 x 1" Pan Screw

### Other Parts

1 x Gable Clock Assembly



## Step 45: Attach Slide to Fort



**Note:** Pre-drill all holes using a 1/8" drill bit before installing the pan screws.

**A:** Place Slide centred in the opening of the (051) Front Wall Panel. Slide must be tight to the outside of (051) Front Wall Panel. (fig. 45.1)

**B:** Attach slide to fort using 3 (S7) #12 x 2" Pan Screws. (fig. 45.1)

Fig. 45.1

**Warning!** Must be tight to (051) Front Wall Panel on both sides

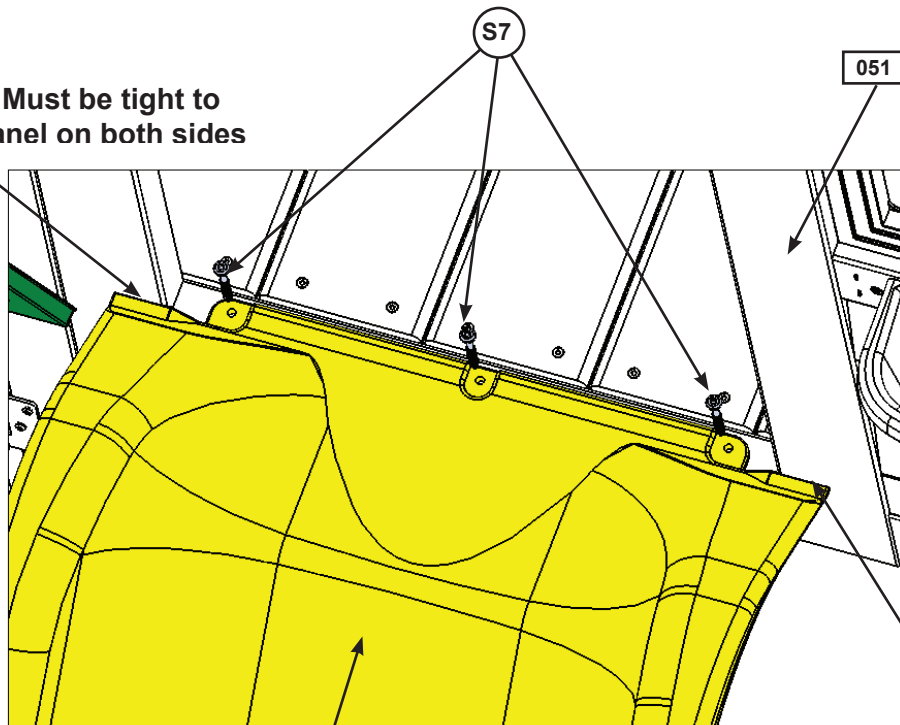

Slide

**Warning!** Must be tight to (051) Front Wall Panel on both sides

**Warning!** Check entire play center for bolts protruding beyond T-Nuts. Use extra washers to eliminate this condition.

### Hardware

3 x (S7) #12 x 2" Pan Screw

### Other Parts

1 x Slide

# Final Step: Attach I.D. Plaque

## ATTACH THIS WARNING & I.D. PLAQUE TO THIS LOCATION ON YOUR PLAY EQUIPMENT!

This provides warnings concerning safety and important contact information. A Tracking Number is provided to allow you to get critical information or order replacement parts for this specific model.



A: Attach I.D. Plaque - KidKraft to a location on your set that is easily seen and read by a supervising adult using 4 (S13) #6 x 5/8" Pan Screws as shown below.

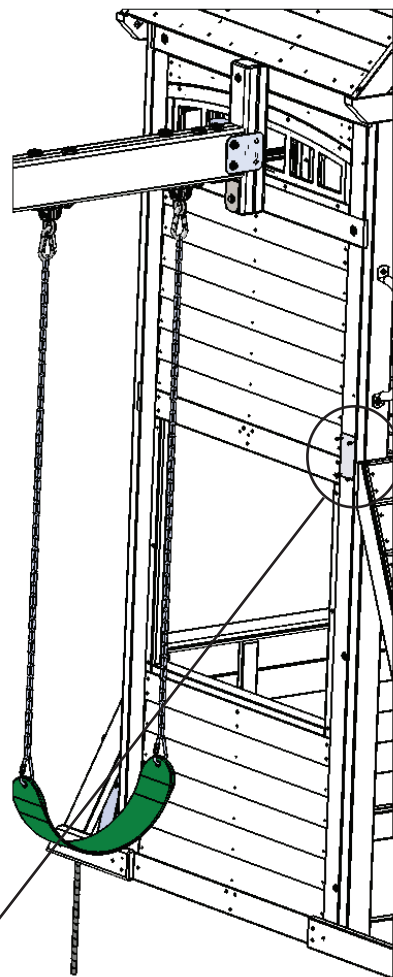

I.D. Plaque - KidKraft

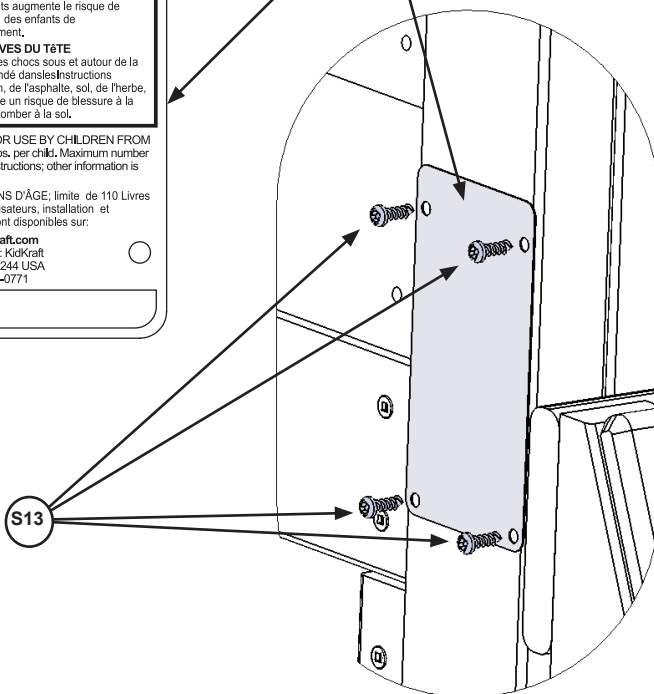

### Hardware

4 x (S13) #6 x 5/8" Pan Screw

### Other Parts

1 x I.D. Plaque - KidKraft



