

# INSTRUCTION MANUAL

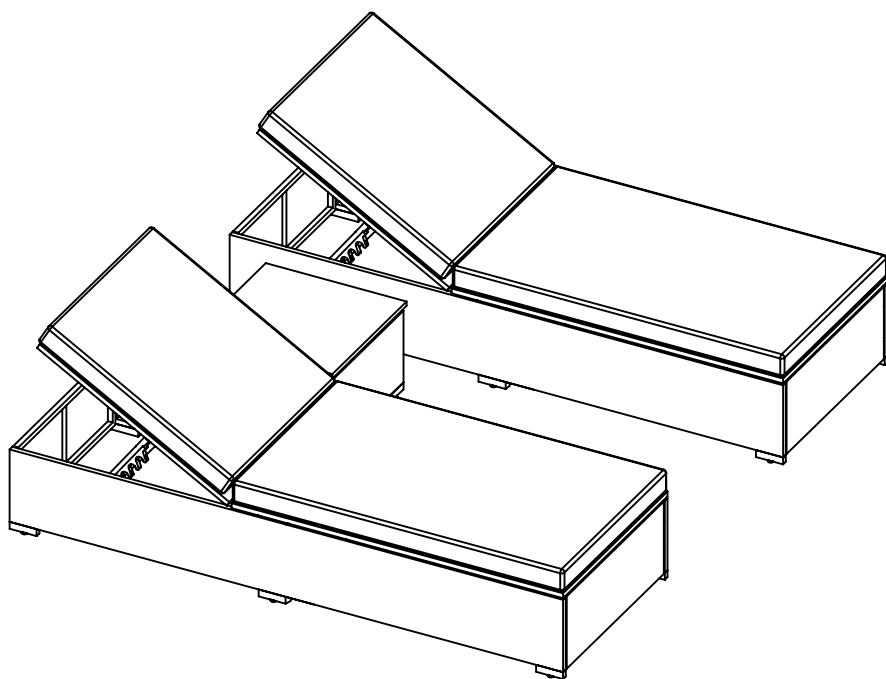

**Sun Lounger Set With Cushions And Table**  
**SKU: OP4001**

V1.0

## ! NOTICE

### Do not overtighten screws. (Insert all screws before tighten screws.)

- Please do not exceed the weight limitations of this item.
- Do not stand on or use any part of this item as a step ladder.
- Firmly secure all bolts, screws and nuts before use.
- Reconfirm that all bolts, screws, and nuts are secure every 90 days.
- Do not use or store this item in the proximity of open flame or flammable/combustible chemicals.
- Be aware that some parts are heavy and have sharp edges.

## TOOLS REQUIRED



ALLEN WRENCH  
(PROVIDED)



LOUNGER  
330 LBS  
CAPACITY



TABLE  
110 LBS  
CAPACITY



2 PERSONS  
ASSEMBLY



UP TO 60 MIN.  
ASSEMBLY

## HARDWARE

1

M6 x 30MM  
BOLT



48 PCS

2

M6 x 15MM  
BOLT



8 PCS

3

M6 WASHER



56 PCS

4

ALLEN  
WRENCH

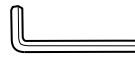

1 PC

## PARTS

A

LOUNGER LEFT PANEL

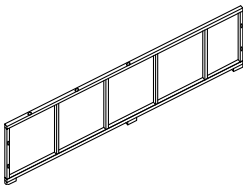

2 PCS

B

LOUNGER RIGHT PANEL

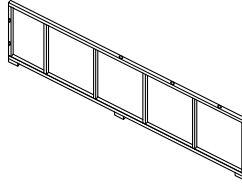

2 PCS

C

LOUNGER END PANEL

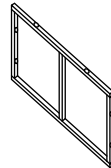

2 PCS

## PARTS

D

LOUNGER END PANEL

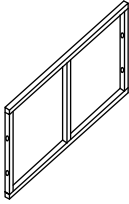

2 PCS

E

BASE STAND SUPPORT

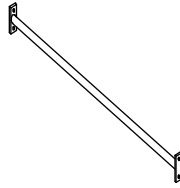

2 PCS

F

LOUNGER BASE

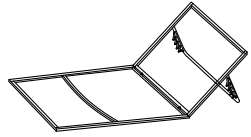

2 PCS

G

TABLE LONG PANEL

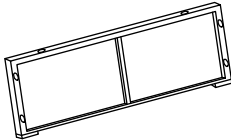

2 PCS

H

TABLE SIDE PANEL

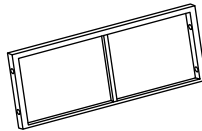

2 PCS

I

TABLE TOP

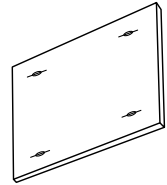

1 PC

## CUSHION

Z1

LOUNGER CUSHION

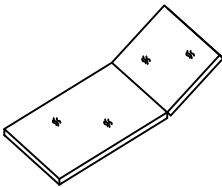

2 PCS

## GLASS

Y1

GLASS TOP

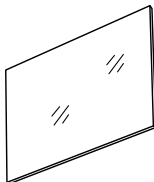

1 PC

## PRODUCT ASSEMBLY - LOUNGER

1

Attach part C Lounger End Panel to part B Lounger Side Panels with 2 PCS of part 1 Bolt and part 3 Washer.

Do not tighten the bolts too much at this stage.

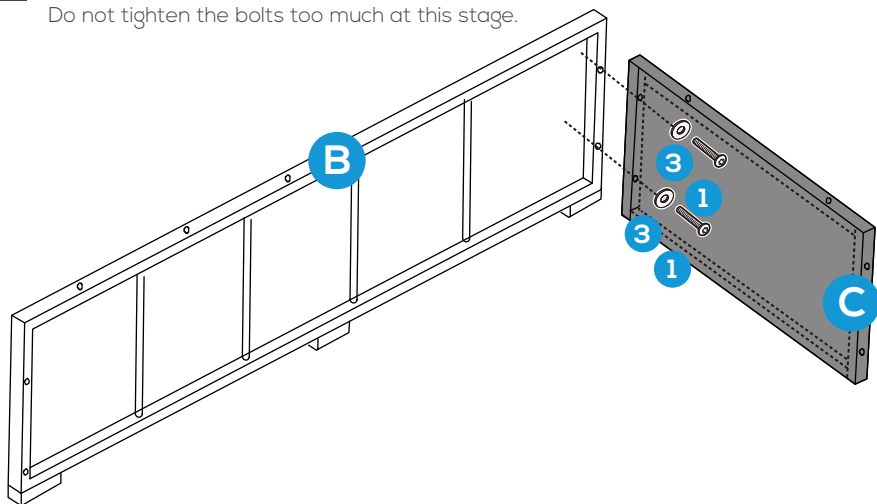

2

Attach part A Lounger Side Panel to part C Lounger End Panel with 2 PCS of part 1 Bolt and part 3 Washer.

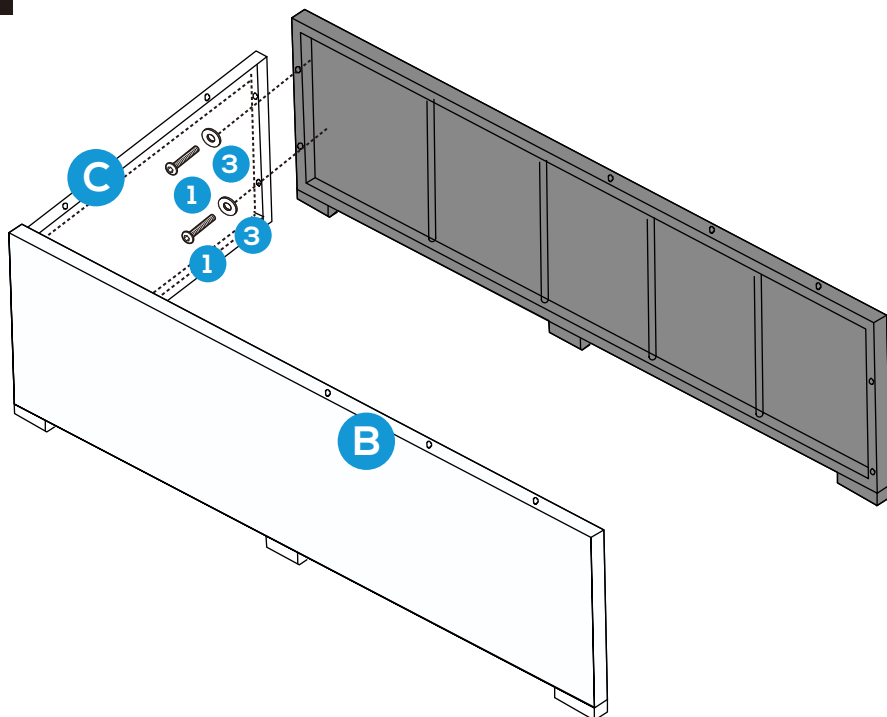

## PRODUCT ASSEMBLY - LOUNGER

3

Attach part D Lounger End panel to part A and B Lounger Side Panels with 4 PCS of part 1 Bolt and part 3 Washer.

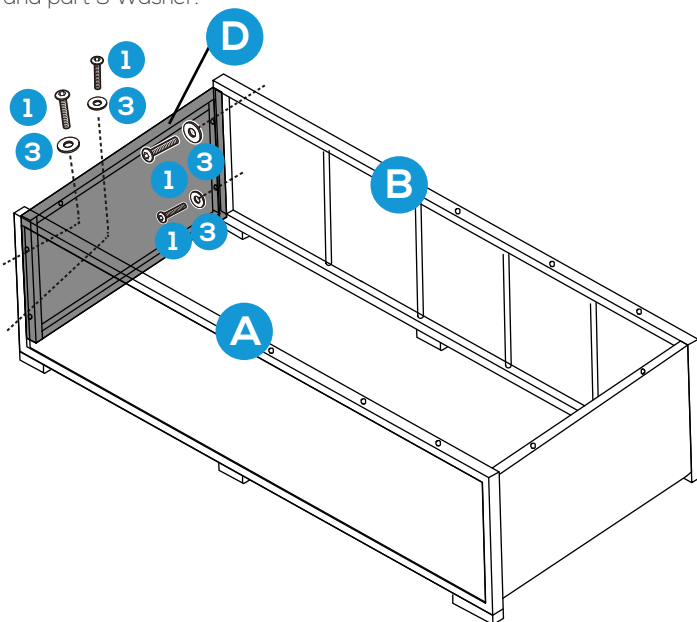

4

Attach part E Base Stand Support to part A and B Lounger Side Panels with 4 PCS of part 2 Bolt and part 3 Washer.

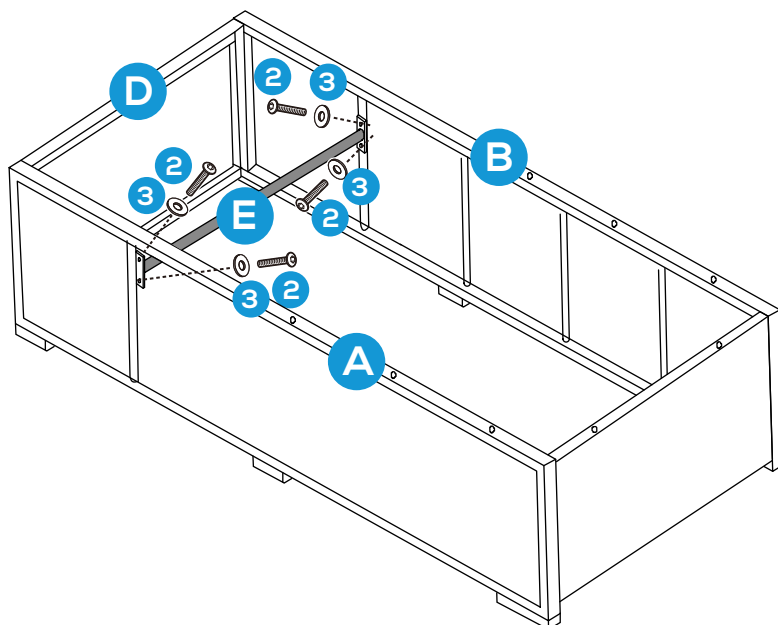

## PRODUCT ASSEMBLY - LOUNGER

5

Attach part F Lounger Base to Lounger Body (combined part A+B+C+D) with 8 PCS of part 1 Bolt and part 3 Washer.

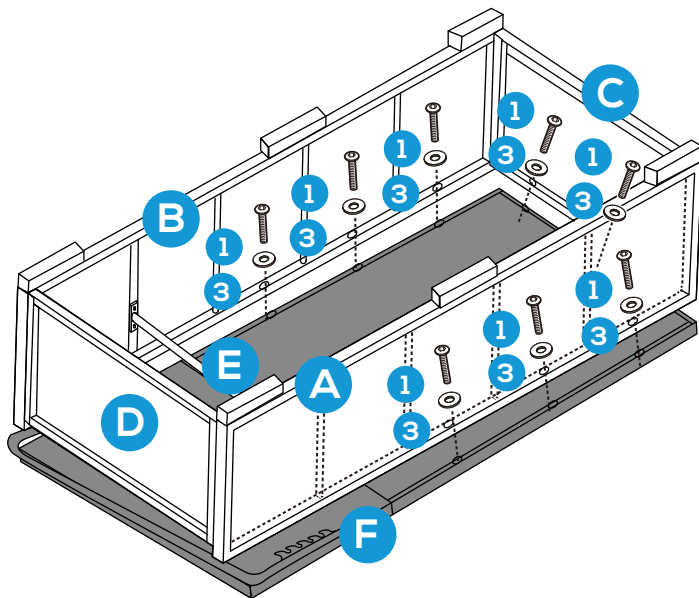

6

Pull the end of the Lounger Base upward and attach the teeth onto part E Stand Support.

Place the Cushion onto the Lounger Base to finish the assembly.

Do the same to assemble another Lounger.

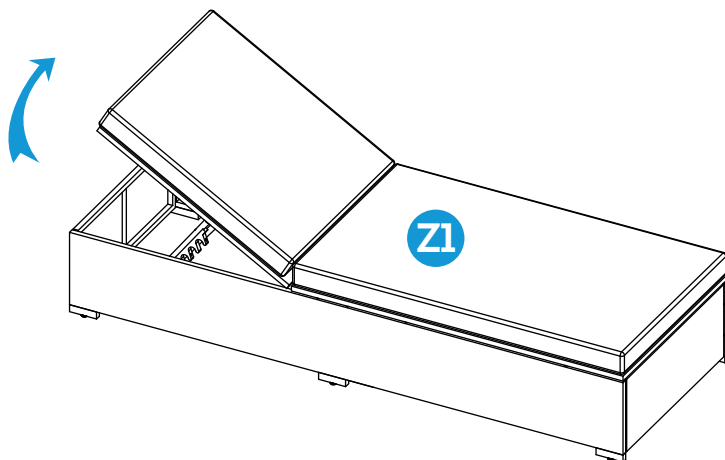

## PRODUCT ASSEMBLY - LOUNGER

7

Attach part G Table Long Panel to part I Table top with 2 PCS of part 1 Bolt and part 3 Washer.

Do not tighten the screws too much at this stage.

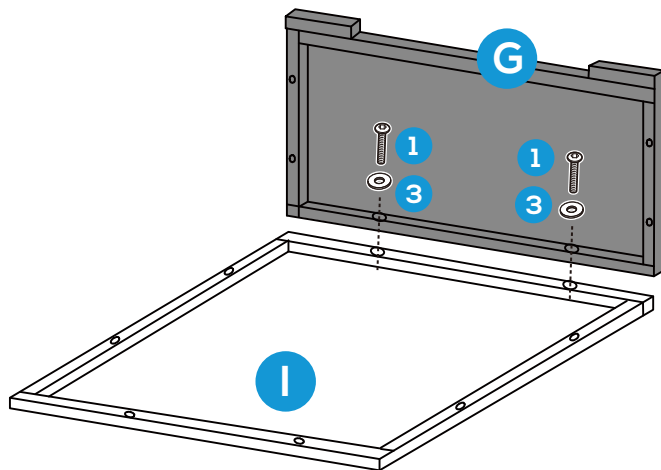

8

Attach 2 PCS of part H Table Side Panels to part G Table Long Panel and part I Table Top with 8 PCS of part 1 Bolt and part 3 Washer.

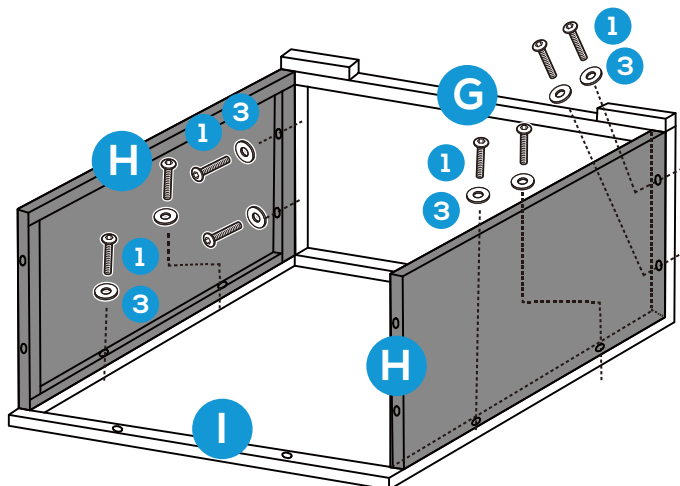

## PRODUCT ASSEMBLY - COFFEE TABLE

9

Attach part G Table Long Panel to part I Table top and part H Table side panels with 6 PCS of part 1 Bolt and part 3 Washer.

Check and tighten all bolts again to ensure this table is steady enough.

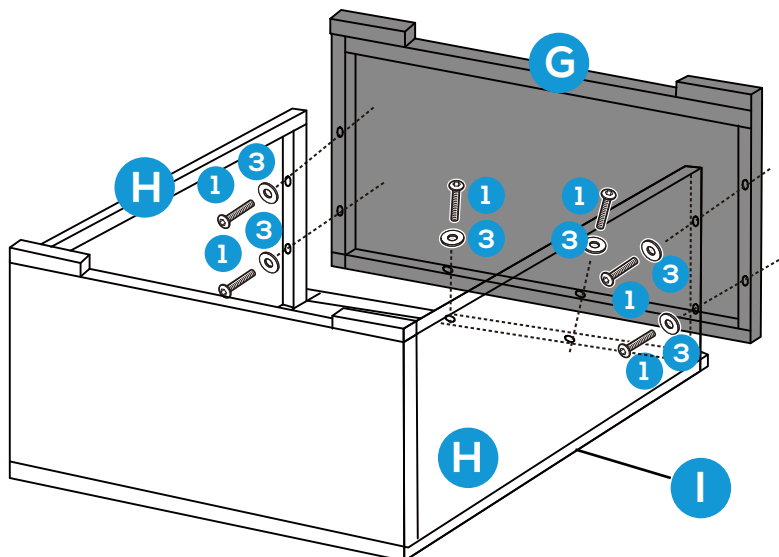

10

Place part Y1 Glass onto the coffee table to finish the assembly.

