

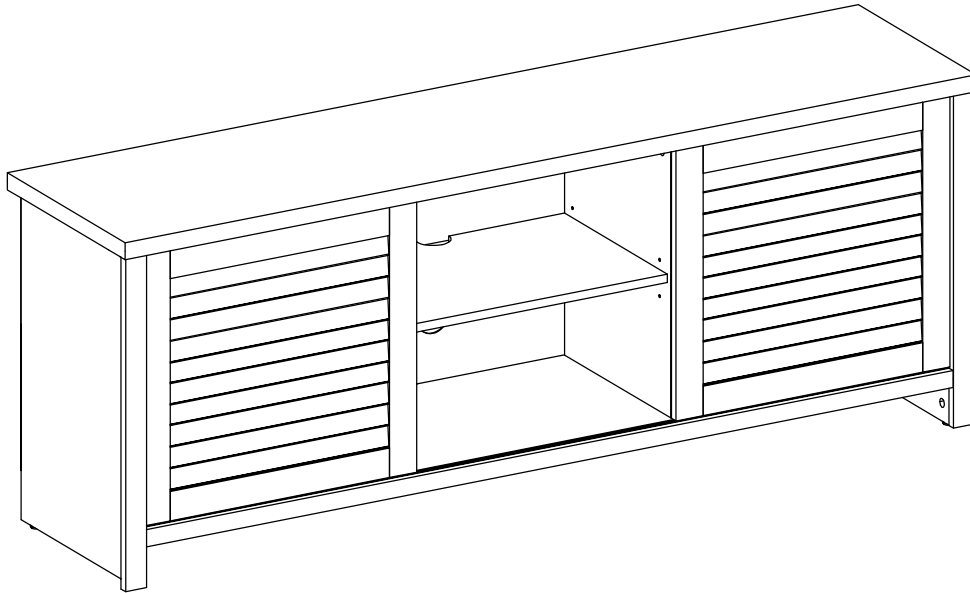

Living Essentials
by
HILLSDALE

WOOD 64 INCH ENTERTAINMENT CONSOLE WITH 2 SLIDING DOOR 2 SHELVES
BOIS CONSOLE DE DIVERTISSEMENT DE 64 POUCHES AVEC 2 PORTE COULISSANTE 2 ÉTAGÈRES
CONSOLA DE ENTRETENIMIENTO DE MADERA DE 64 PULGADAS CON 2 PUERTA CORREDERA 2 ESTANTES



6526-881
6527-881

Made in indonesia
Fabriqué en indonésie
Hecho en indonesia

Examine all packaging material for small parts that may have come loose during shipment. Periodic checks are recommended to ensure that a components are in proper position, tight and free from damage. Keep this assembly instruction for future reference. Adult assembly is required.

Examine el material de embalaje en busca de piezas pequeñas que puedan haberse aflojado durante el transporte. Se recomienda realizar verificaciones periódicas para asegurar que todos los componentes est én en la posición correcta, apretados y libres de daños. Guarde estas instrucciones de ensamblaje para referencias futuras. El ensamblaje debe ser realizado por un adulto.

Examinez tous les matériaux d'emballage por les petites pièces qui peuvent avoir été lâché pendant le transport. Des contrôles périodiques sont recommandées afin d'assurer que tous les composants sont en bonne position, tendu et sans dommages. Gardez ces instructions de montage pour référence future. Assemblage par un adulte est requise.

⚠ DANGER**• Risk of suffocation! •**

Keep any packaging materials away from children.

⚠ PELIGRO**¡Riesgo de sofocación!**

Mantenga los materiales de embalaje lejos de los niños.

⚠ DANGER**• Risque d'asphyxie! •**

Maintenez tous les matériaux d'emballage à l'écart des enfants.

Before Getting Started

- Read the instructions carefully prior to assembling the product.
- Carefully remove all packaging materials and retain for future use.
- Choose a clean, level, spacious assembly area. Avoid hard surfaces that may damage the product.
- Ensure that you have all required contents for complete assembly.
- Take care when lifting. Assemble the product in close proximity to where you intend to position the item.
- Do not over tighten the screws and bolts and be careful using power tools as they may damage the threads.
- When you have finished assembling the product, place it on a flat surface and make sure it is stable before use.
- Please do not completely tighten bolts and/or screws until assembly is finished.

Cleaning & Maintenance

- Keep the product away from direct heat and sunlight.
- Prolonged exposure to heat sources may cause glazing, melting and scorching, or even cause color to fade.
- Regular vacuuming or light brushing helps to remove dirt and prevent soil build-up, which increases the appearance wear.
- Periodically (every 90 days) make sure that the screws are fully tightened.

Metal Furniture Care Instructions

- For everyday cleaning, chrome, brass, aluminum, and painted metal surfaces can be kept looking their best by wiping with a slightly damp, soft cotton cloth, or vacuum cleaner brush.
- If soiled, wipe with clean sponge or cloth wrung out of water. Wipe dry with cloth or paper towel to avoid water spots.
- Do not use any harsh abrasives or chemicals to clean any metal surfaces as it may damage the protective coating.
- Metal will rust if the finish is scratched or if your product is exposed to excessive humidity, particularly in salt water locations.
- Liquid spills should be removed immediately. Using a soft clean cloth, blot the spill gently. Avoid rubbing.

Antes de Comenzar

- Lea las instrucciones cuidadosamente antes de ensamblar el producto.
- Retire con cuidado todos los materiales de embalaje y consérvelos para usarlos en el futuro.
- Elija un área de ensamblaje limpia, nivelada y espaciosa. Evite las superficies duras que puedan dañar el producto.
- Asegúrese de tener todos los contenidos necesarios para el ensamblaje completo.
- Tenga cuidado al levantar. Arme el producto muy cerca de donde desea colocar el artículo.
- No apriete demasiado los tornillos ni los pernos, y tenga cuidado al usar herramientas eléctricas ya que pueden dañar las roscas.
- Cuando haya terminado de armar el producto, colóquelo en una superficie plana y asegúrese de que sea estable antes de usarlo.
- No apriete completamente los pernos y / o los tornillos hasta que termine el ensamblaje.

Limpieza y Mantenimiento

- Mantenga los muebles lejos del calor y la luz solar directa.
- La exposición prolongada a las fuentes de calor causa cristalización, derretimiento, quemadura y decoloración del tapizado.
- Pasar la aspiradora con regularidad o cepillar suavemente ayuda a quitar la suciedad y evitar la acumulación de tierra en las fibras de la tela, que aumentan el desgaste aparente.
- Periódicamente (cada 90 días) asegúrese de que los tornillos estén bien apretados.

Instrucciones Para el Cuidado de Muebles de Metal

- Para una limpieza diaria, las superficies de cromo, bronce, aluminio y de metal pintado se mantienen mejor limpiándolas con un trapo de algodón suave, levemente humedecido, un sacudidor o con el cepillo de la aspiradora.
- Si hay manchas límpielas con una esponja o un trapo limpio húmedo (exprimido). Seque completamente con un trapo a una toalla de papel para evitar manchas de agua.
- No utilice productos abrasivos o químicos fuertes para limpiar las superficies de metal. Se puede dañar el revestimiento protector.
- El metal se oxida si se raya o acabado o se exponen los muebles a humedad excesiva, en particular, en locaciones de zonas húmedas o de la zona costera.

Avant de Commencer

- Lisez attentivement les instructions avant d'assembler le produit.
- Retirez soigneusement tous les matériaux d'emballage et conservez-les pour tout usage ultérieur.
- Choisissez une zone de montage propre, plane et spacieuse. Évitez les surfaces dures susceptibles d'endommager le produit.
- Assurez-vous d'avoir tout le contenu requis pour l'assemblage complet.
- Faites attention lorsque vous soulevez le produit. Assemblez le produit à proximité de l'endroit où vous souhaitez positionner l'article.
- Ne serrez pas trop les vis et les boulons et soyez prudent avec les outils électriques car ils pourraient endommager le filetage.
- Une fois l'assemblage du produit terminé, placez-le sur une surface plane et assurez-vous qu'il est stable avant utilisation.
- Ne serrez pas complètement les boulons et / ou les vis tant que l'assemblage n'est pas terminé.

Nettoyage et Entretien

- Maintenez le produit à l'écart de toute source de chaleur directe et de la lumière directe du soleil.
- Une exposition prolongée à des sources de chaleur est susceptible d'entraîner la cristallisation, la fonte, la combustion ou encore la décoloration du produit.
- Un nettoyage régulier à l'aspirateur ou un léger brossage régulier permet de retirer la saleté et de prévenir l'accumulation de terre, ce qui augmente l'usure apparente.
- Périodiquement (tous les 90 jours), assurez-vous que les vis sont bien serrées.

Instructions d'Entretien Des Meubles en Métal

- Pour le nettoyage quotidien de surfaces de métaux tels que le cuivre, le chrome, l'aluminium ou les surfaces métalliques peintes, essuyez à l'aide d'un chiffon doux et légèrement humide en coton ou encore avec une brosse d'aspirateur. Cela vous permettra de maintenir l'apparence de vos meubles.
- Si le meuble est sale, essuyez à l'aide d'une éponge propre ou d'un chiffon essoré. Épongez la surface avec un chiffon sec ou une serviette en papier pour éviter les taches d'eau.
- N'utilisez pas d'abrasifs ou de produits chimiques corrosifs pour nettoyer le métal, puisque cela pourrait abîmer le revêtement protecteur.
- Si la finition est égratignée ou si vos meubles sont exposés à une humidité excessive, particulièrement dans les endroits où il y a de l'eau salée, le métal rouillera.



“Warning - For use with televisions weighing 135 lbs (61,3 Kg) or less. Use with heavier televisions may result in instability causing tip over resulting in death or serious injury”

Plasma/LCD flat panel TV screen of various screen sizes to a maximum TV screen size 55 inches.

All other support shelves should not be loaded with more than 25 lbs.

DO NOT EXCEED RECOMMENDED LOAD. Use with products heavier than the maximum sizes and weights indicated may result in instability causing possible injury.

Do not allow children under 16 years to move unit.

DO NOT REMOVE THIS LABEL.

Manufactured: Hillsdale Furniture, LLC

SKU#: 6526-881 / 6527-881

Manufactured Date:

PARTS

CONTENTS

Before getting started, ensure the packages contains the following components:

CONTENIDO

Antes de comenzar, asegurese de quel el paquete contenga los siguientes componentes:

CONTENU

Avant de commencer, assurez-vous que l'emballage contient les composants suivants:

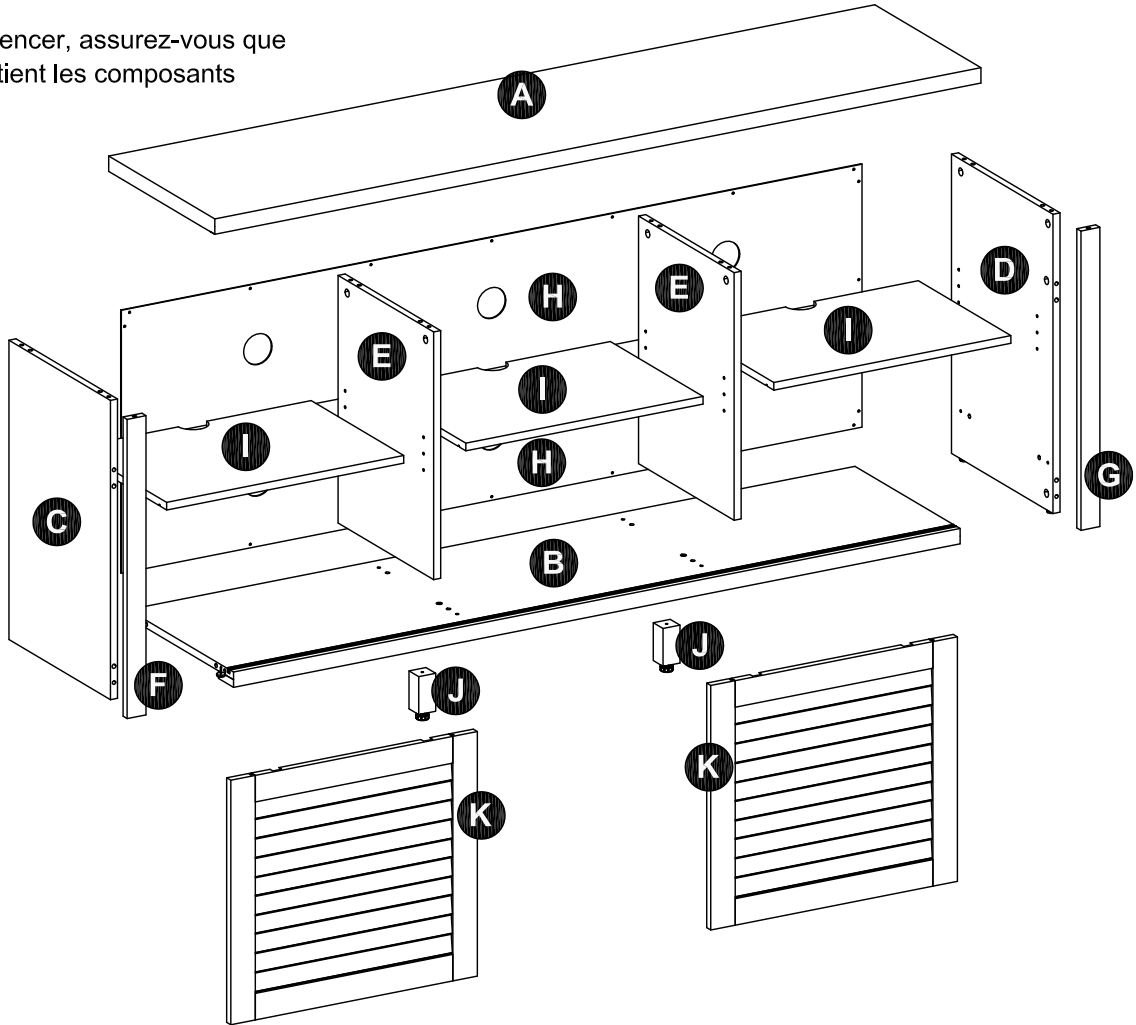

| No. | Part Name | Pieces |
|-----|-------------------|--------|
| A | Top panel | 1 |
| B | Bottom frame | 1 |
| C | Left side panel | 1 |
| D | Right side panel | 1 |
| E | Partition | 1 |
| F | Front post-left | 1 |
| G | Front post-right | 1 |
| H | Folded-Back panel | 2 |
| I | Shelf | 3 |
| J | Center leg | 2 |
| K | Door | 2 |

HARDWARE



1. Cam Nut 15 mm
16 x

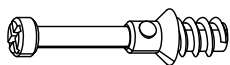

2. Cam Bolt
16 x

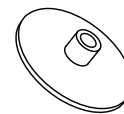

3. Cover Cap
12 x

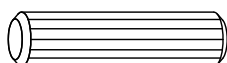

4. Dowel Ø8 x 32mm
22 x



5. Screw Ø10 x 33.5mm
6 x

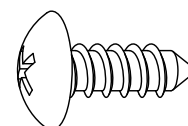

6. Screw Ø3 x 12mm
26 x

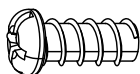

7. Screw Ø4 x 10mm
16 x

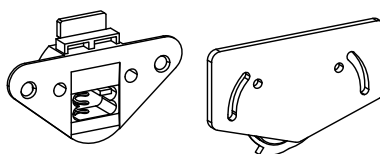

8. Sliding roller set
4 set



9. Shelf pin
12 x

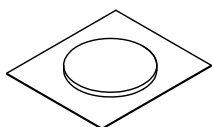

10. Bumpers Pads
6 x

TOOLS REQUIRED FOR ASSEMBLY (NOT INCLUDED)

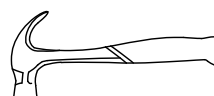
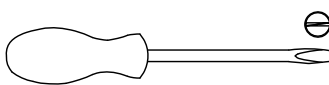
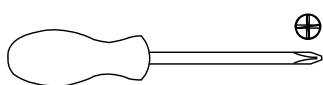

DO NOT USE POWER TOOLS TO ASSEMBLE THIS PRODUCT. USE POWER TOOLS WILL INVALIDATE ANY CLAIM AND MAY DAMAGE THIS PRODUCT MAKING IT UNSAFE.

NOT USE HERRAMIENTAS ELÉCTRICAS PARA MONTAR ESTE PRODUCTO. EL USO DE LAS HERRAMIENTAS ELÉCTRICAS INVALIDARÁ CUALQUIER RECLAMO T PUEDE DAÑAR ESTE PRODUCTO QUE LO PONE SEGURO.

N'UTILISEZ PAS D'OUTILS ÉLECTRIQUES POUR ASSEMBLER CE PRODUIT. L'UTILISATION DES OUTILS ÉLECTRIQUES ANNULERA TOUTE RÉCLAMATION ET PEUT ENDOMMAGER CE PRODUIT LE RENDANT SECURITAIRE.

Assembly / Montaje / Assemblage

STEP 1 / ETAPA 1 / ÉTAPE 1

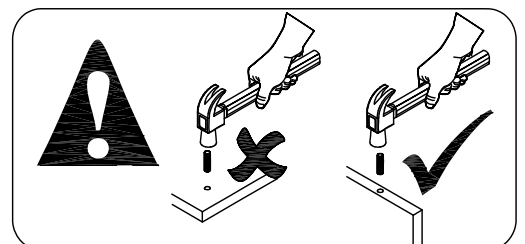
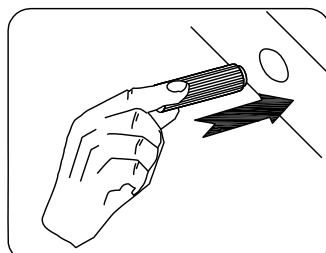
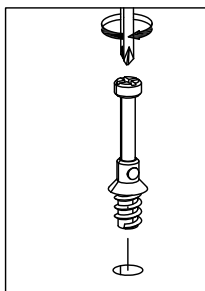
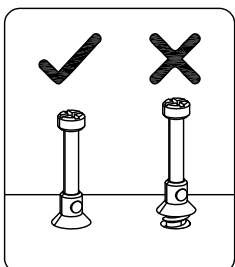
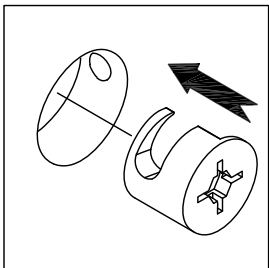
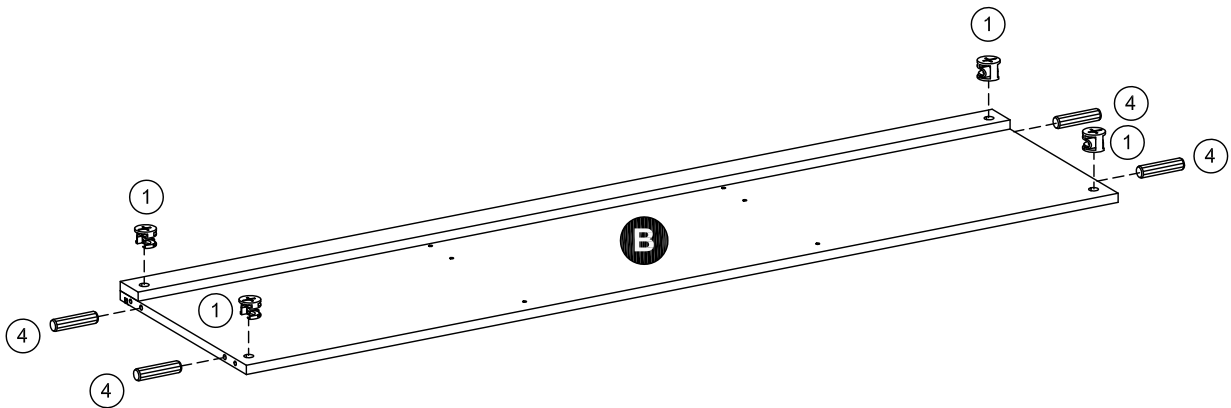
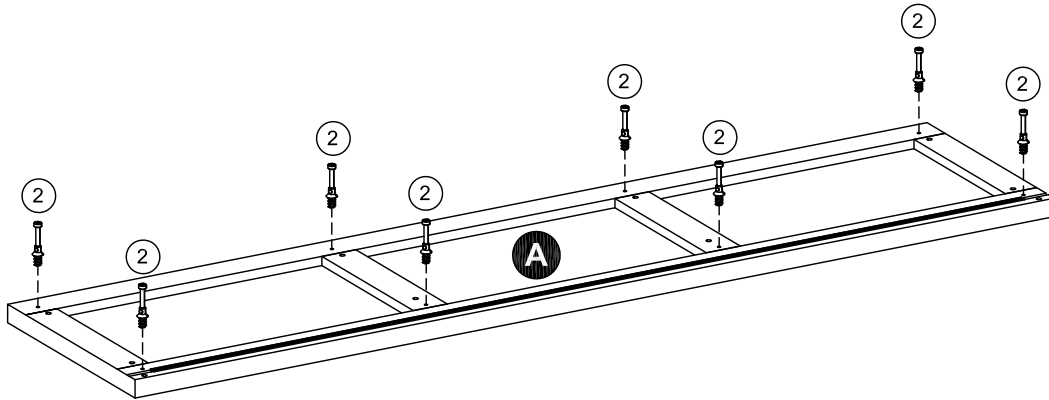
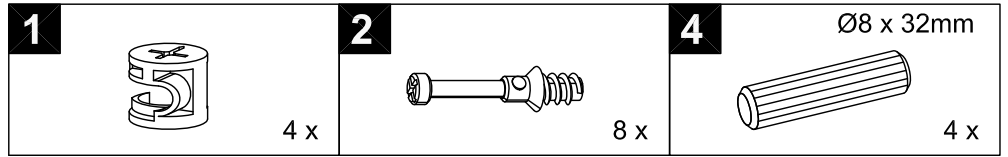

STEP 2 / ETAPA 2 / ÉTAPE 2

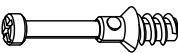
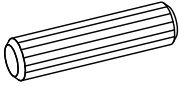
| | | | | | |
|----------|---|----------|--|----------|---|
| 1 |  | 2 |  | 4 |  |
| | 12 x | | 8 x | | Ø8 x 32mm 18 x |

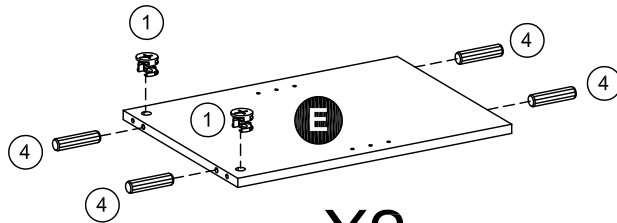
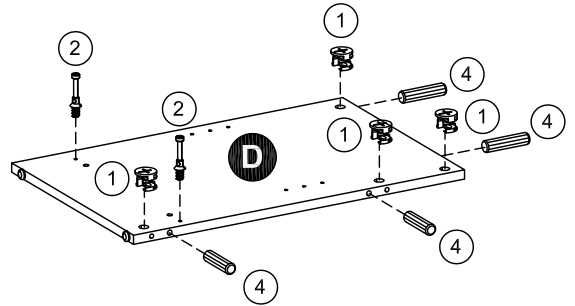
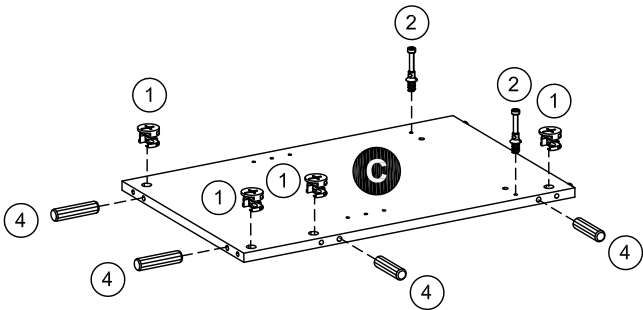

X2

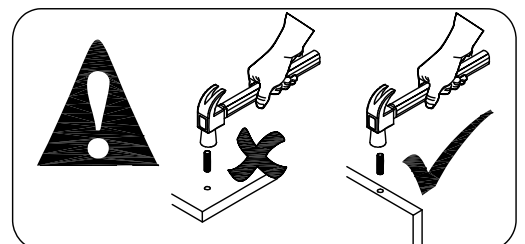
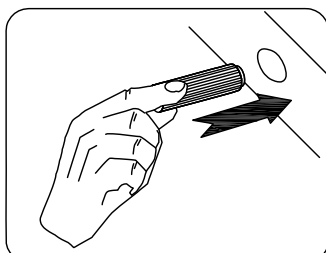
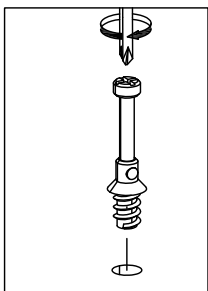
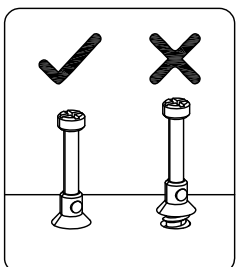
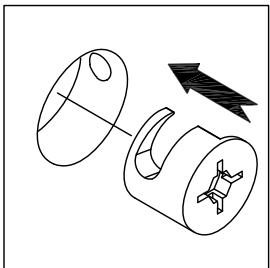
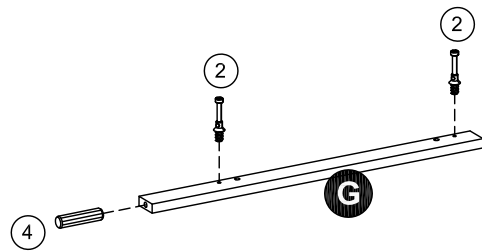
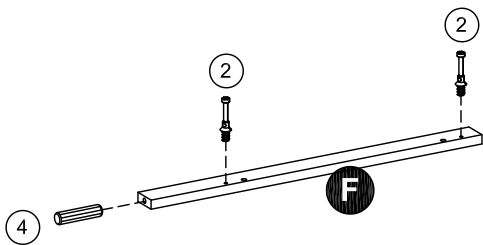

STEP 3 / ETAPA 3 / ÉTAPE 3

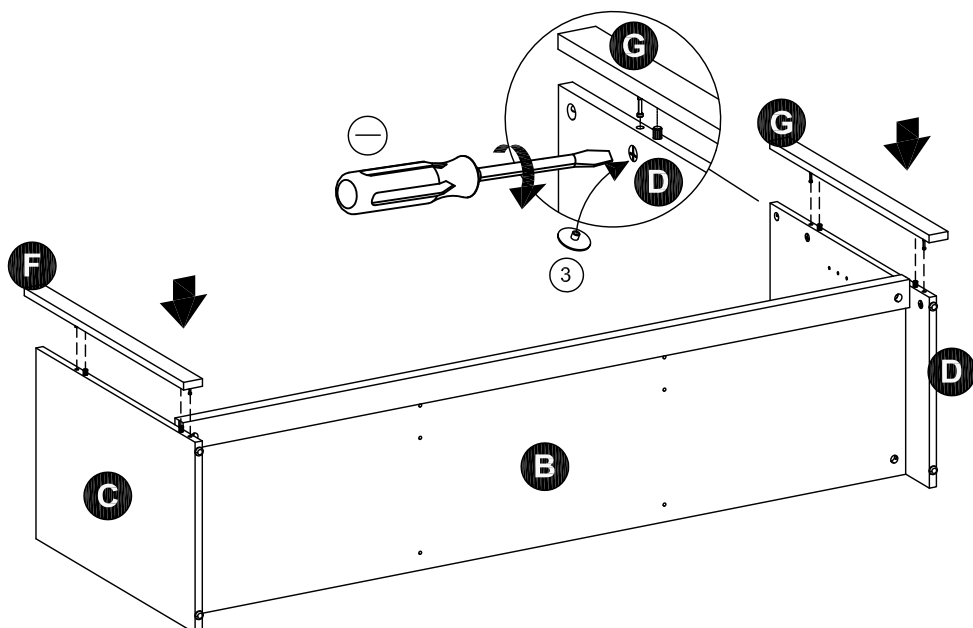
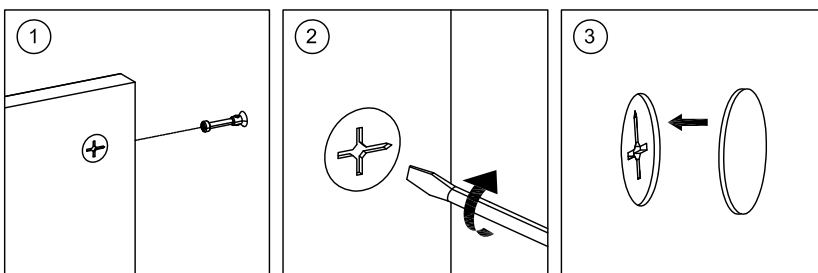
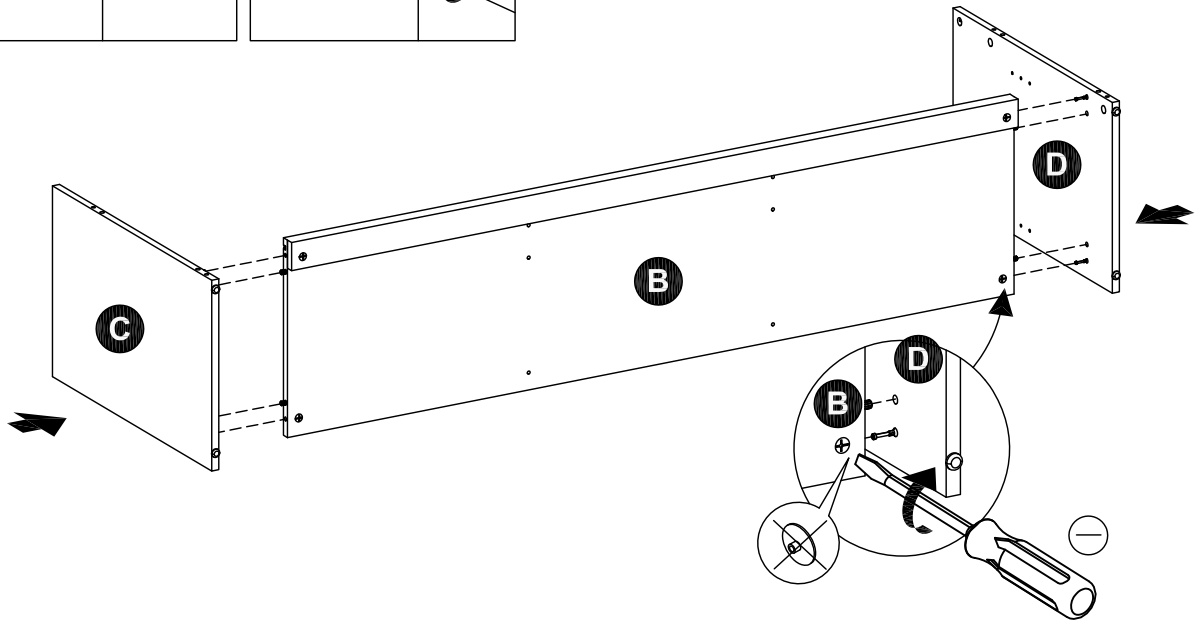
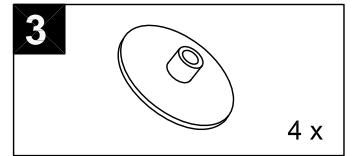
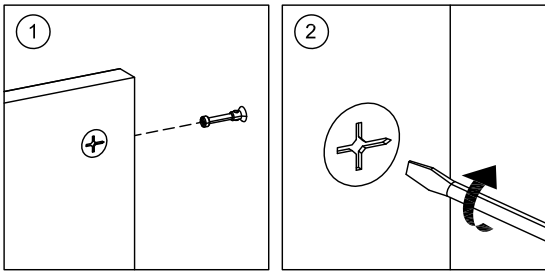

STEP 4 / ETAPA 4 / ÉTAPE 4

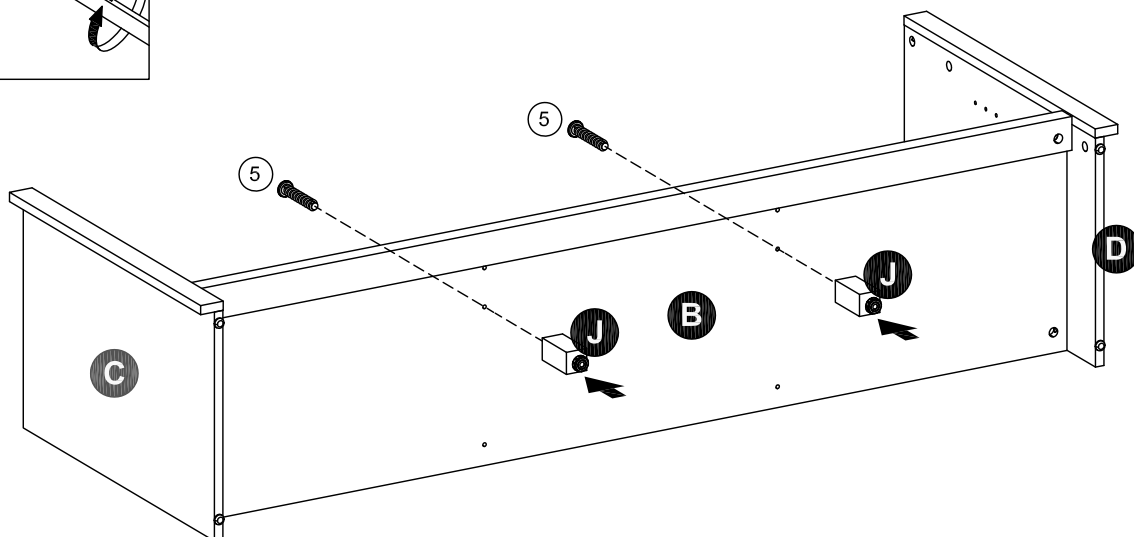
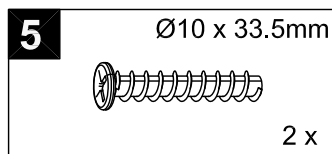
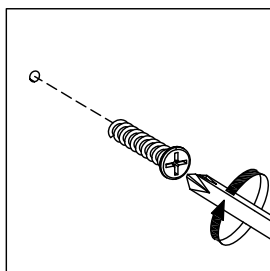

STEP 5 / ETAPA 5 / ÉTAPE 5

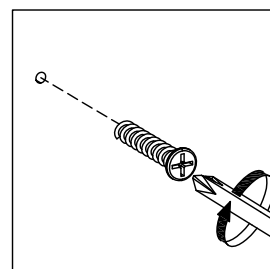
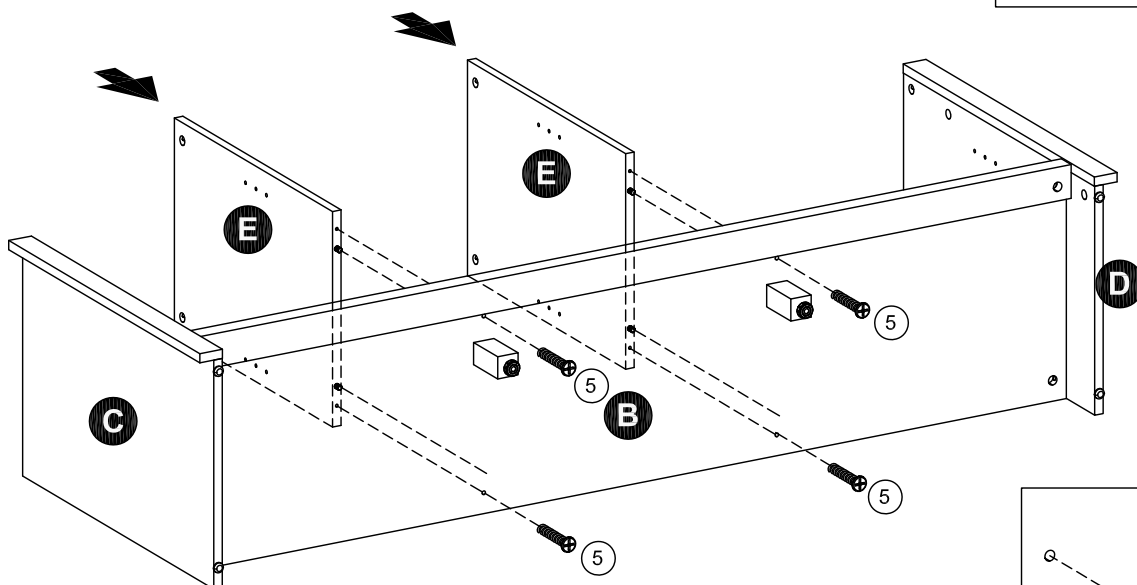
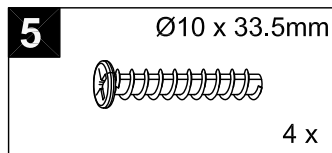

STEP 6 / ETAPA 6 / ÉTAPE 6

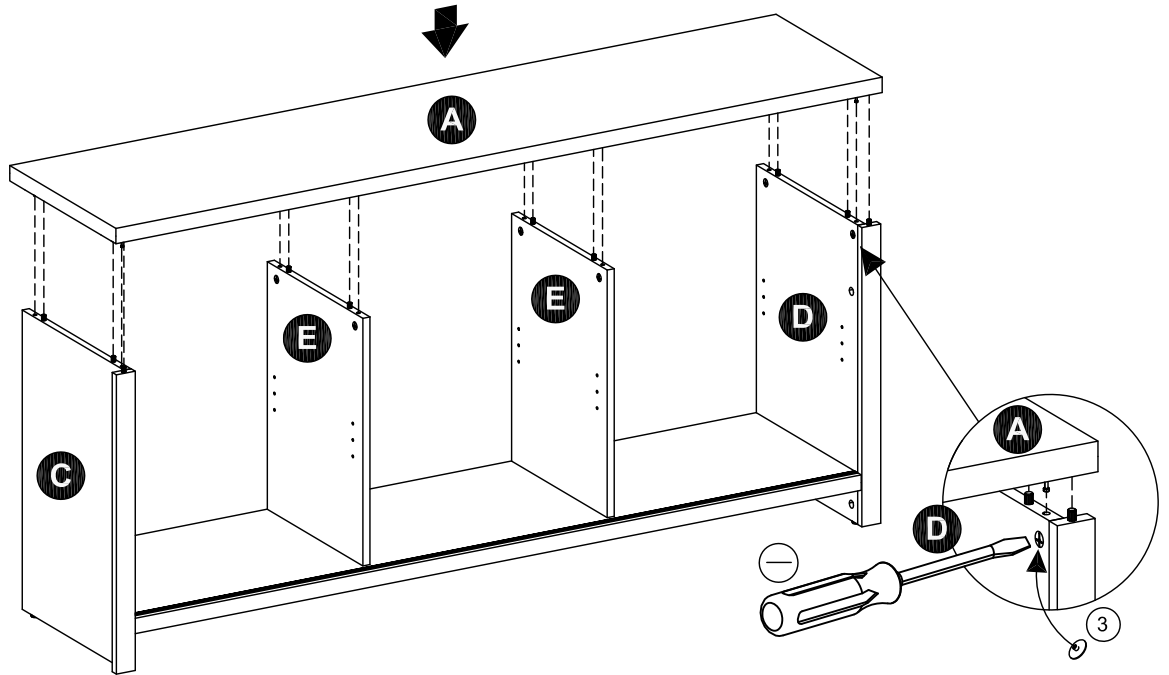
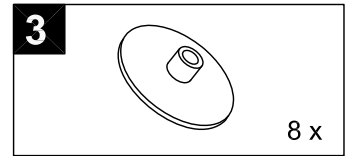
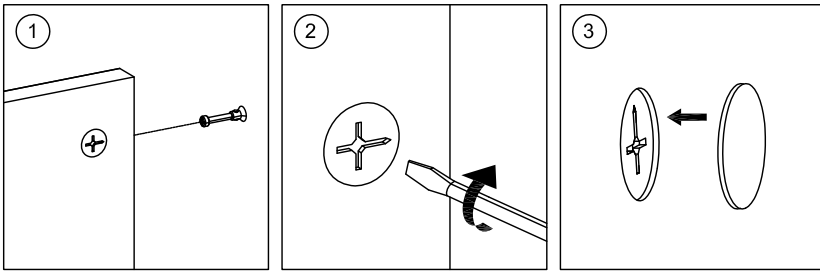

STEP 7 / ETAPA 7 / ÉTAPE 7

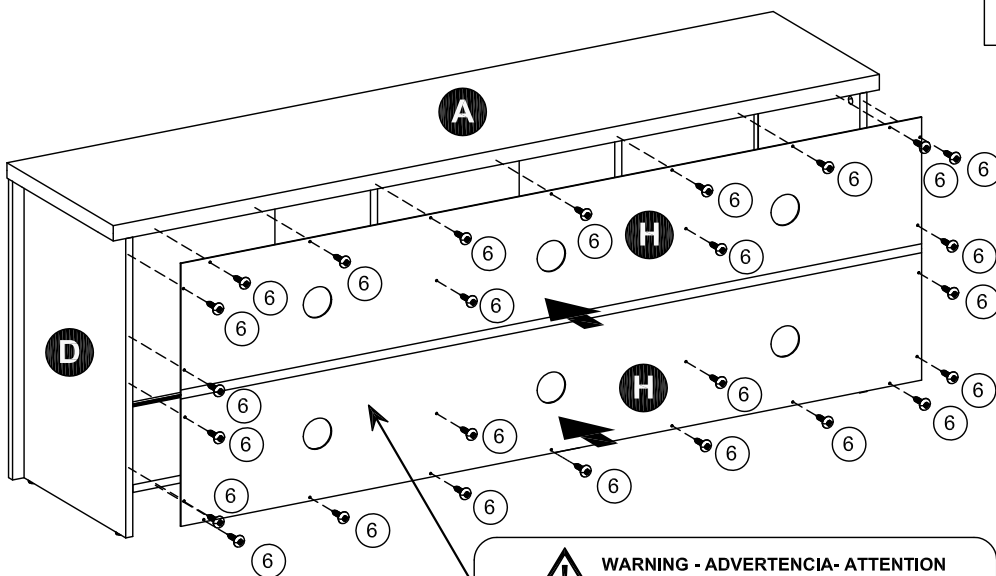
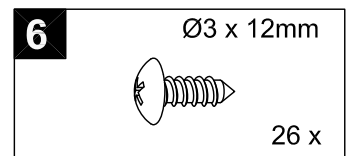

WARNING - ADVERTENCIA- ATTENTION

Unfinished/ raw face of the back panel must be outside-facing.
 La cara sin terminar / en bruto del panel posterior debe estar orientada hacia el exterior.
 La face non finie / brute du panneau arrière doit être tournée vers l'extérieur.

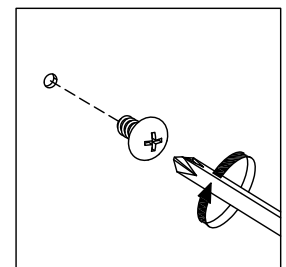

STEP 8 / ETAPA 8 / ÉTAPE 8

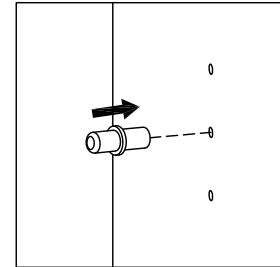
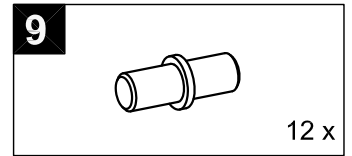
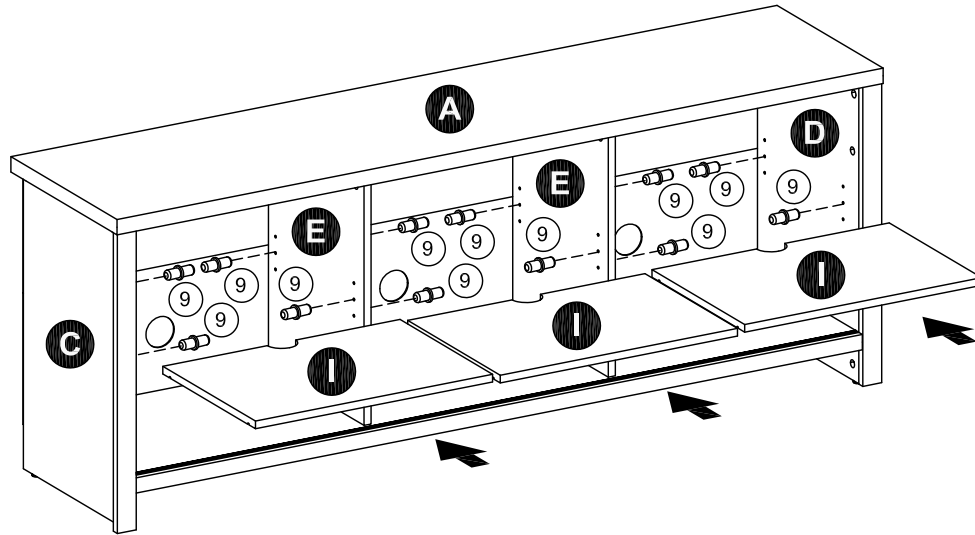

STEP 9 / ETAPA 9 / ÉTAPE 9

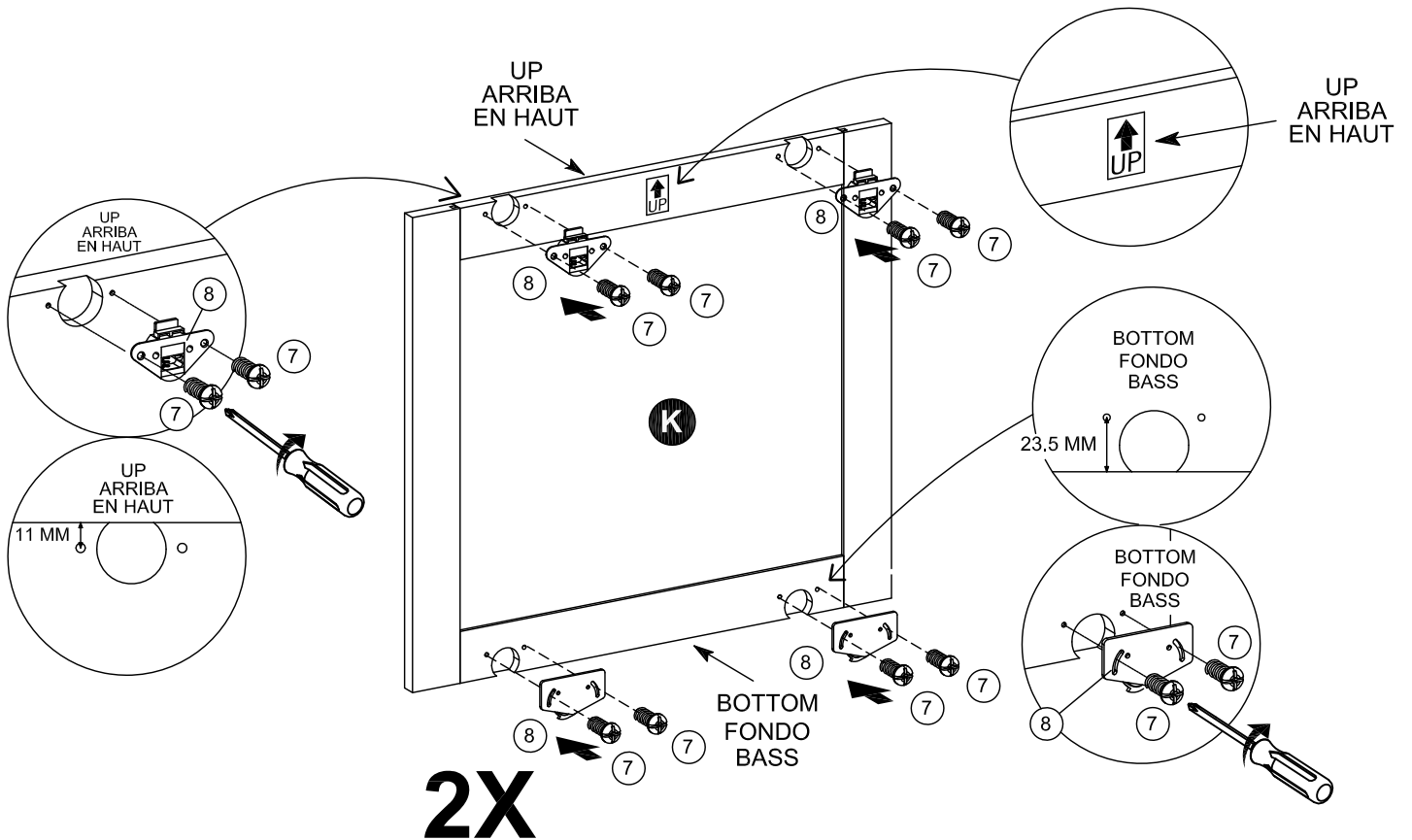
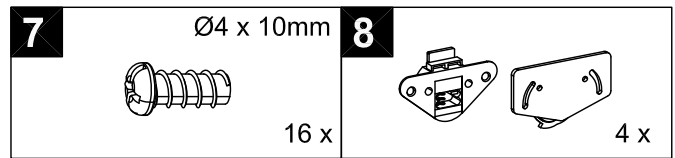

STEP 10 / ETAPA 10 / ÉTAPE 10

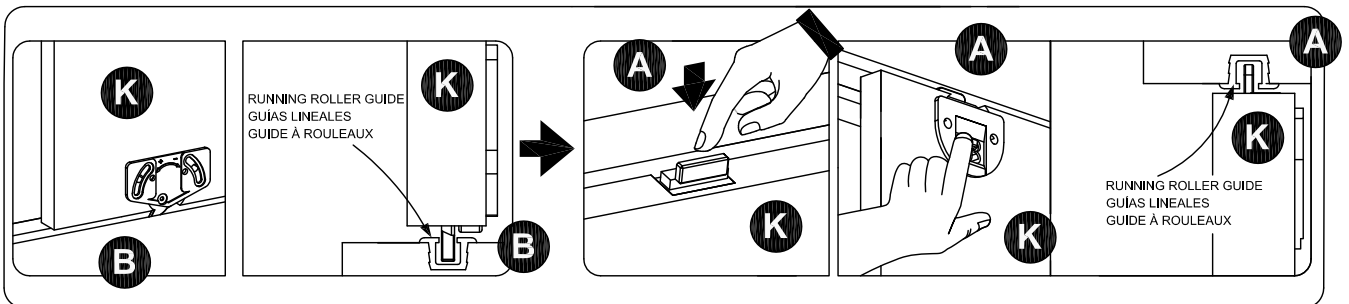
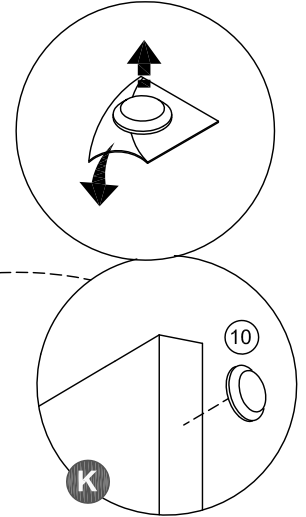
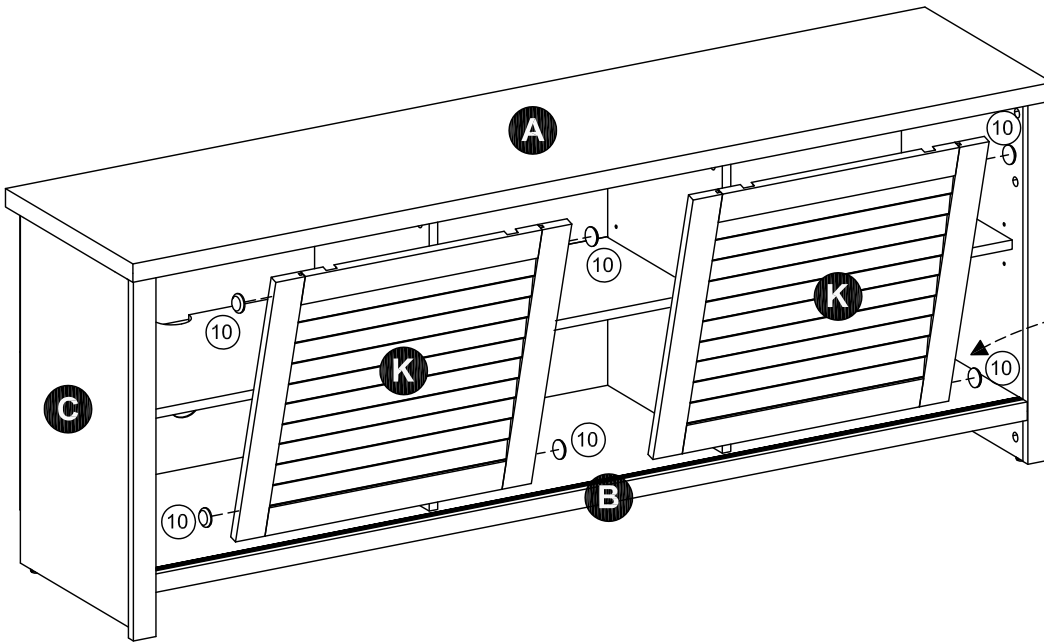
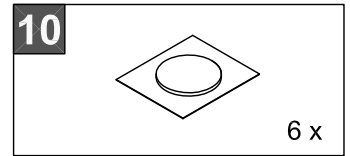

RUNNING ROLLER ADJUSTMENT GUIDE
GUÍA DE AJUSTE DEL RODILLO CORRIENTE
GUIDE DE RÉGLAGE DES ROULEAUX DE COURSE

| | | |
|---|---|---|
| <p>UP ARRIBA EN HAUT</p> <p>①</p> | <p>STANDARD ESTÁNDAR. LA NORME</p> <p>②</p> | <p>DOWN. ABAJO. VERS LE BAS.</p> <p>③</p> |
|---|---|---|

DOOR'S GAPS
HUECOS DE LA PUERTA
GAPS DE PORTE

STEP 11 / ETAPA 11 / ÉTAPE 11

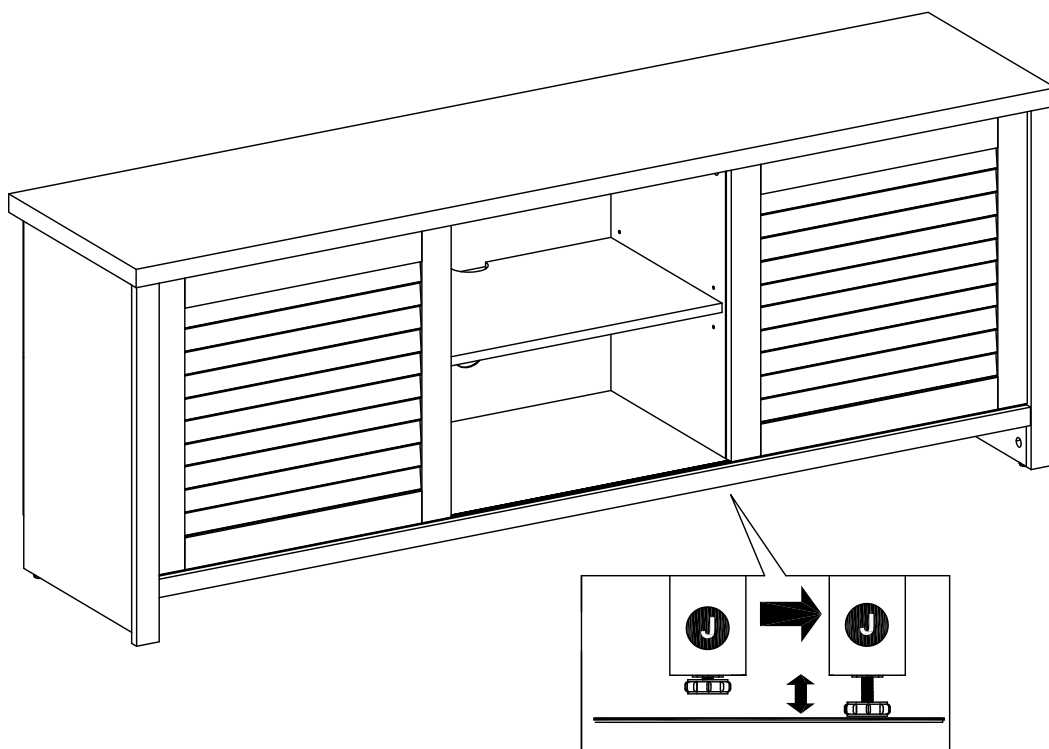

DOIN' THE *Happy* Dance?



Connect with us! Share a photo of you and your new piece of furniture with the hashtag #HillsdaleHome or tag us and you could be featured on Hillsdale's Social Media!

www.HillsdaleFurniture.com

-  [hillsdale_furniture](https://www.instagram.com/hillsdale_furniture)
-  [hillsdalefurniture](https://www.facebook.com/hillsdalefurniture)
-  [HillsdaleFurn](https://www.youtube.com/HillsdaleFurn)



UH OH!

Is there a product defect, a part missing, or questions on how to best assemble?

We want to help!

Call or email our Support Team below:

directship@hillsdalefurniture.com

502-562-0000