

ASSEMBLY INSTRUCTIONS & PARTS MANUAL

Q-Line Hinged Door Shelving Units: HDS-8712RH, HDS-8718RH & HDS-8724RH



RETAIN INSTRUCTIONS FOR FUTURE REFERENCE



GENERAL SAFETY INFORMATION

Some parts may have sharp edges. CARE must be taken when handling various pieces to avoid injury. For safety, wear a pair of work gloves when assembling or performing any maintenance on units.

LIMITED WARRANTY

Tennsco warrants goods purchased hereunder to be free of defects in materials and workmanship for a period of one (1) year from the date of shipment, hereunder. This warranty shall not apply in the event goods are damaged as a result of misuse, abuse, neglect, accident, improper application, modification or repair by persons not authorized by Seller, where goods are damaged during shipment, or where the date stamps on the goods have been defaced, modified or removed. UNLESS CONSIDERED UNENFORCEABLE OR UNLAWFUL UNDER APPLICABLE LAW:

- a. ALL IMPLIED WARRANTIES, INCLUDING BUT NOT LIMITED TO WARRANTIES OR MERCHANTABILITY AND FITNESS FOR A PARTICULAR PURPOSE ARE HEREBY EXCLUDED:
- b. BUYERS REMEDY, IF ANY, FOR ANY DEFECTIVE GOODS SHALL BE LIMITED TO A REFUND BY SELLER OR REPLACEMENT OF THE GOODS AT SELLER'S OPTION, AND SHALL IN NO EVENT INCLUDE DAMAGES OF ANY KIND, WHETHER INCIDENTAL, CONSEQUENTIAL OR OTHERWISE.

NO GOODS ACCEPTED FOR RETURN WITHOUT PRIOR APPROVAL. Seller shall have the right to inspect any goods claimed to be defective at Buyers place of business or require Buyer to return the goods to Seller for inspection on Seller's premises. Transportation charges covering returned goods will be borne by Seller only if such goods are proven to be defective, are covered by this warranty and are returned within the warranty period stated above.



PROUDLY MADE IN THE U.S.A.

Tennsco LLC., Dickson, TN 37056-1888 • (866) 446-8686

ASSEMBLY OF HINGED DOOR Q-LINE INDUSTRIAL SHELVING

Two people are recommended for assembly. Approximate assembly time: 30-45 minutes.

Tools required: $\frac{7}{16}$ " nut driver or socket and a flathead screwdriver.

The reference numbers used throughout this sheet refer to the illustration on the back cover.

This is to help you to identify the various parts as they are mentioned.

1. Create the right side of the shelving units by laying two uprights side by side on a flat surface. Be sure that the short side of the OAP upright(s) (Ref. No. 1) is facing up, as shown below.

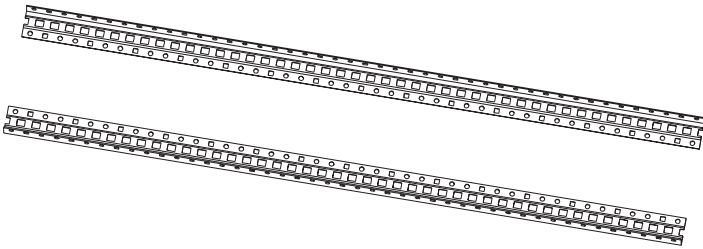

NOTE: One side of the upright is longer than the other, and contains two sets of holes. When laying the uprights side by side, this long side should be on the floor, and the short side should be pointing into the air.

2. Place an end panel (Ref. No. 2) on the uprights. Bolt the panels into the small holes near the edge of both uprights using $\frac{1}{4}$ "-20 x $\frac{5}{8}$ " bolts and nuts (Ref. No. 12). Leave 16 or 17 holes (16" or 17") between each bolt, as shown in the circles on the drawing below.

Also, if you can predetermine where you want your shelf levels to be, you should try to position the bolts where they will not interfere with the shelves; this will avoid having to move them later. Finger tighten only at this point, as binding may occur during shelf placement if the side panels are attached too tightly.

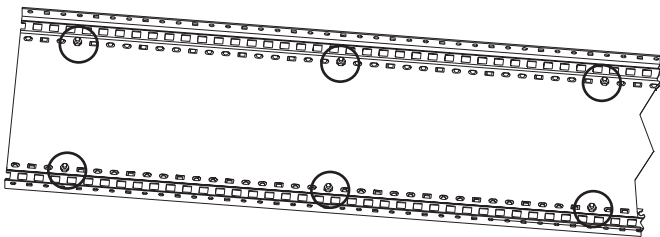

NOTE: The three holes at the top of the upright must be left open, as shown below to avoid interference with the top shelf later.

3. Repeat steps 1 and 2 for the left uprights.

4. Lay the unit back (Ref. No. 3) on a flat surface and attach on end to it using $\frac{1}{4}$ "-20 x $\frac{5}{8}$ " bolts and nuts spaced 16" or 17" apart as described in step 3. Once again, leave the top three holes empty to allow for the top shelf.

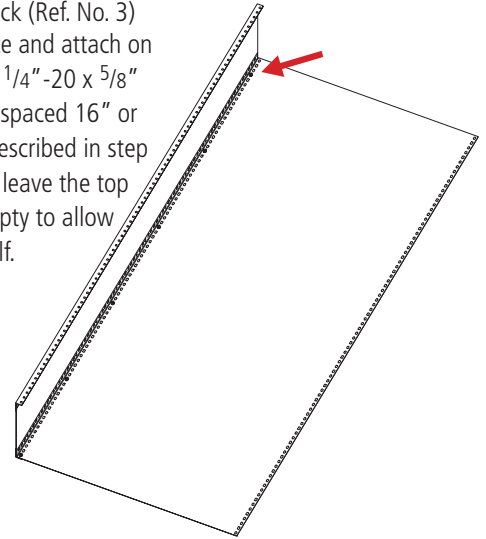

5. With the help of an associate, hold the first upright up as you attach the other upright in the same way as above.

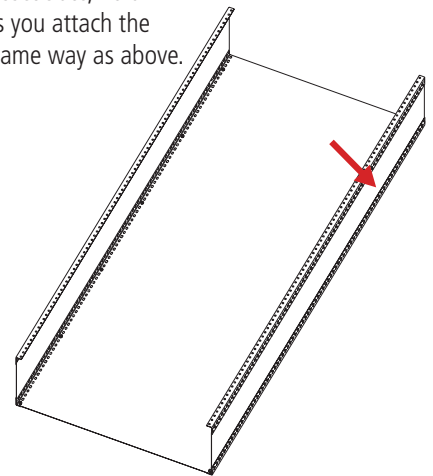

6. With an associate still holding the two uprights, insert four shelf clips (Ref. No. 4) into the top two slots of each side of each upright.

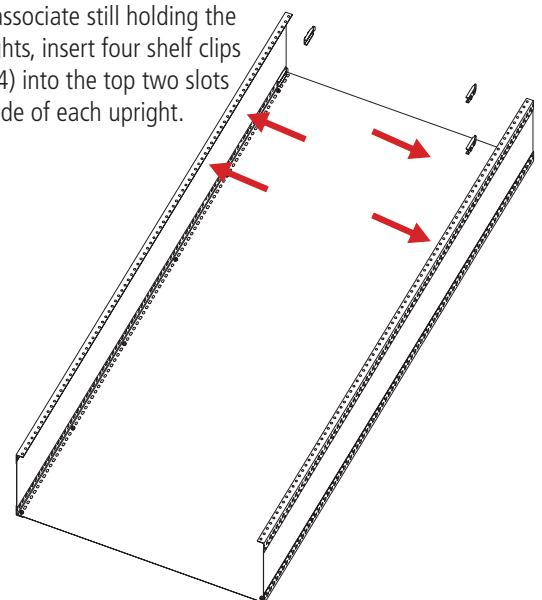

- 7.** Place the top shelf (Ref. No. 5) over the four clips at the top of the uprights. Be sure that the shelf is pushed securely into the clips.

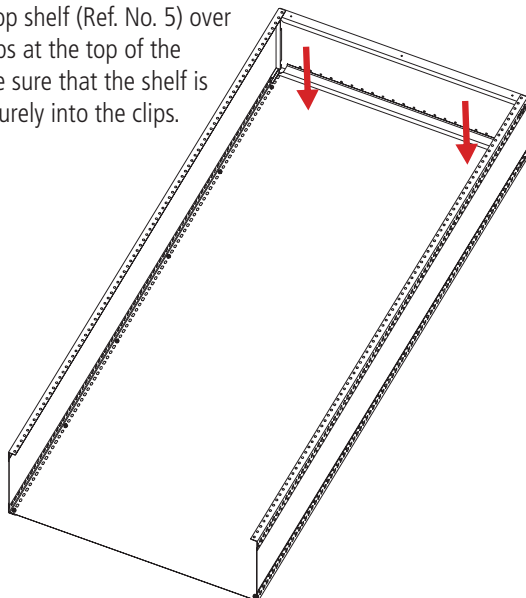

- 8.** Insert four shelf clips into the bottom slots of the uprights in the same way that you did in the top of the uprights in step 6.

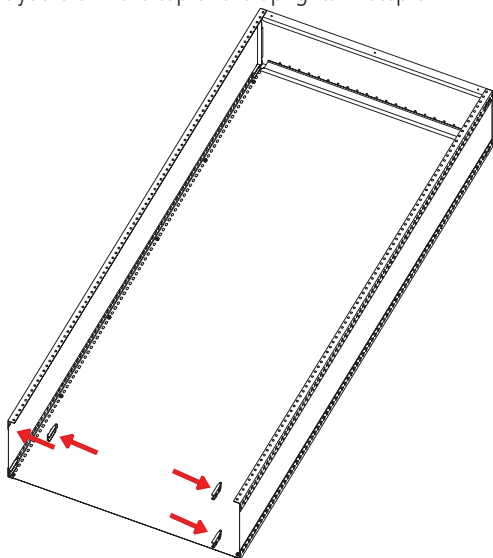

- 9.** As you did in step 7, place a shelf securely onto the bottom four clips.

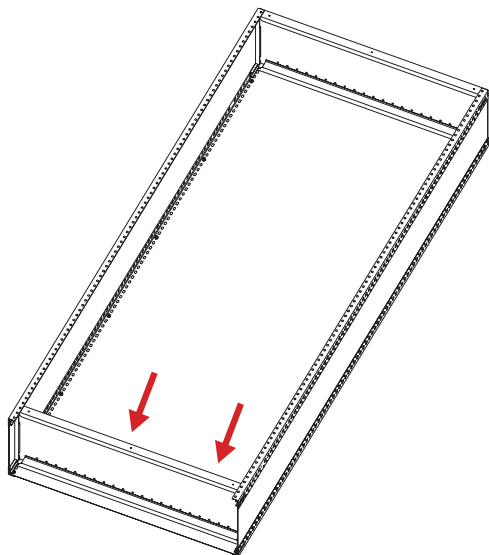

NOTE: Once the bottom shelf is in place, use the help of an associate to carefully lift the top end of the unit so that the shelving unit is standing upright.

- 10.** Position the remaining shelf clips according to your desired shelf heights, then place the shelves over the clips. Keep in mind while placing the clips, that the post hole pattern of two round holes and then one square hole which is repeated every 3", can greatly help in positioning the clips at the same level.

NOTE: Some shelves, depending upon placement, could possibly require repositioning of some of the back and end panel bolts in order to insert the shelf.

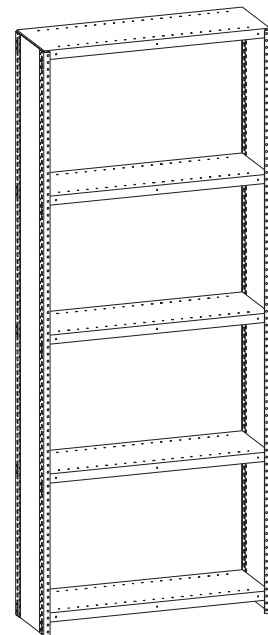

- 11.** Tighten up all bolts and nuts on the side panels.

NOTE: Make sure unit is square and level before tightening the nuts and bolts.

- 12.** For added strength, place two $\frac{1}{4}$ "-20 x $\frac{5}{8}$ " bolts and nuts through each corner of each shelf, and into the small holes of the uprights.

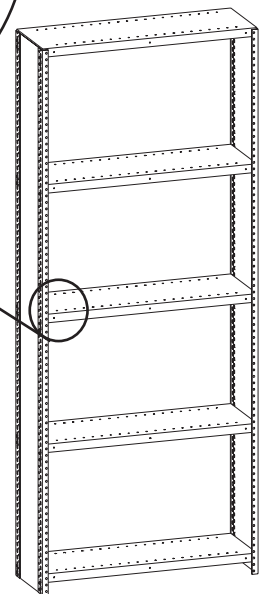
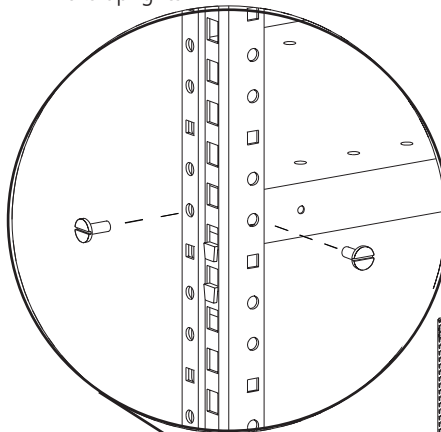

- 13.** Stand the door frame assembly (Ref. No. 6) in an upright position against the front face of the shelving unit.

NOTE: Make sure the door with the opening for the locking handle is on the right side when facing the unit.

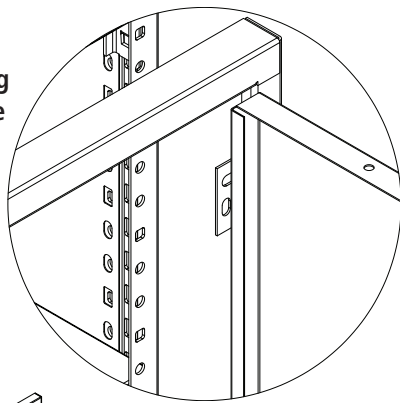

Close-up view shows door from behind

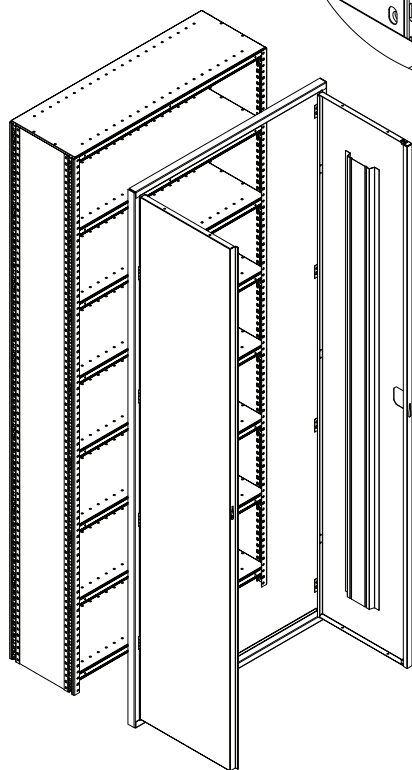

- 14.** With the door frame assembly in approximate position, align the angle flanges on the inside of the door frame with the proper holes on the uprights of the shelving unit.

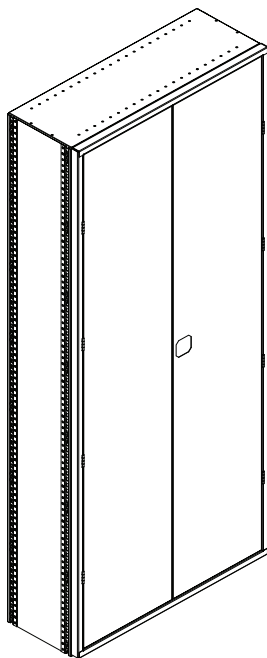

- 15.** Insert one 1/4"-20 x 5/8" bolt through each hole and secure with a 1/4" x 20 nut.

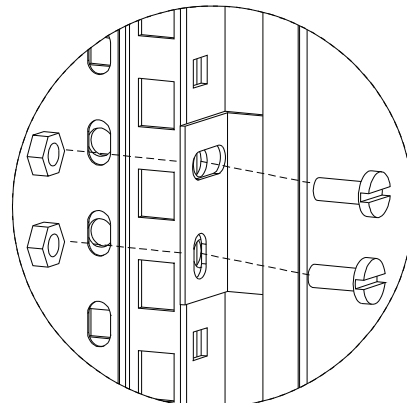

- 16.** Repeat steps 2 and 3 for each angle flange of the door frame. There will be eight flanges on the door.

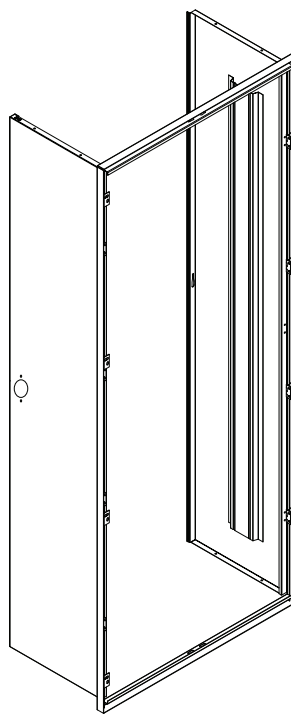

- 17.** The door assembly is now attached. Finish off the unit by attaching the recessed handle. Follow the instructions on the next page.

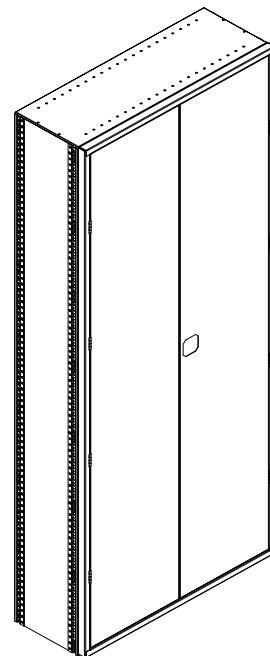

Handle/Locking System Installation

- 18.** Place the locking handle (Ref. No. 8) on the right hand door and push it until it snaps into place. Then turn the handle to the open position. The latch should be facing downward as shown.

Inside view

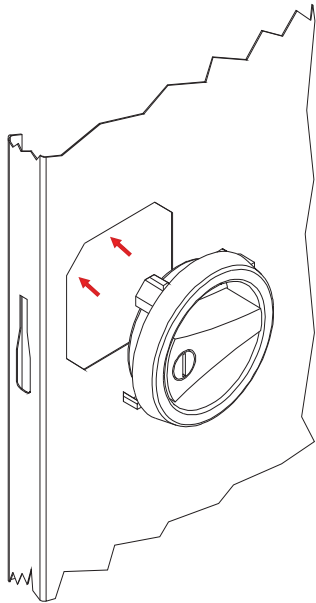
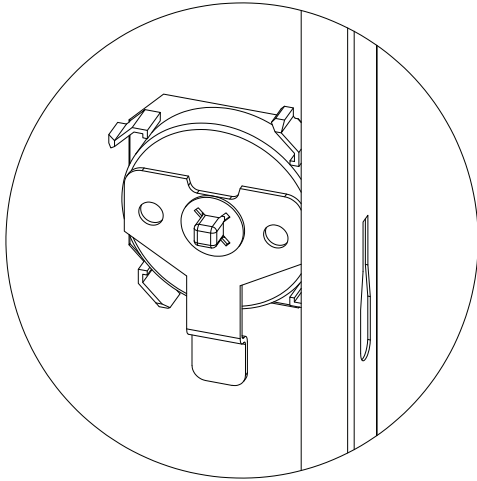

- 19.** With the handle still in the open position, hook the locking bars (Ref. No. 7) to the locking cam (Ref. No. 9).

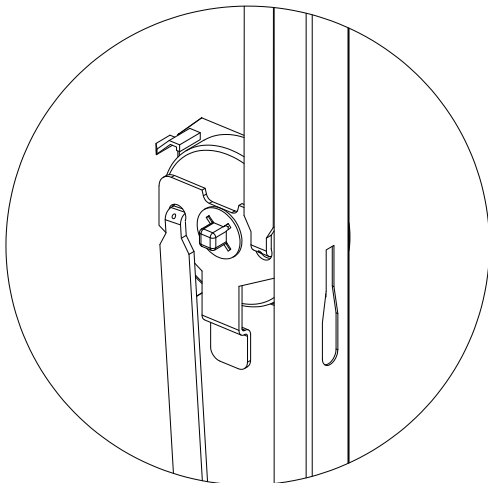

- 20.** Slowly rotate the door handle to the closed position so the lock bars protrude from the holes at the top and bottom of the door (shown below).

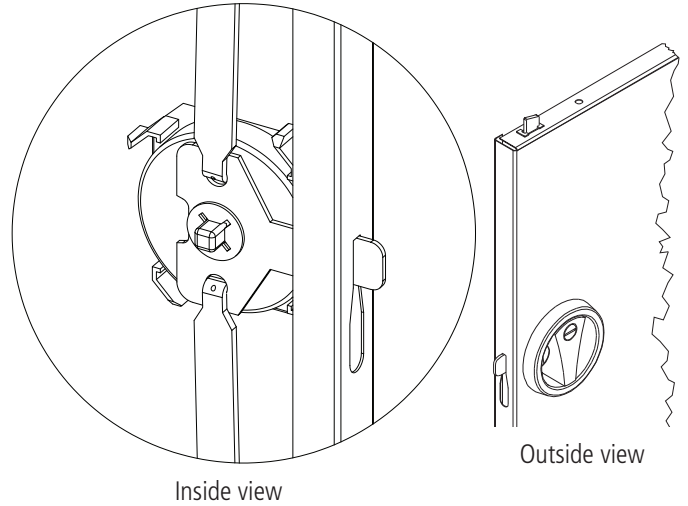

- 21.** Slide the nylon lock bar guide inserts (Ref. No. 10) over the lock bar ends and through the door slots. Push down firmly until the guides snap into place.

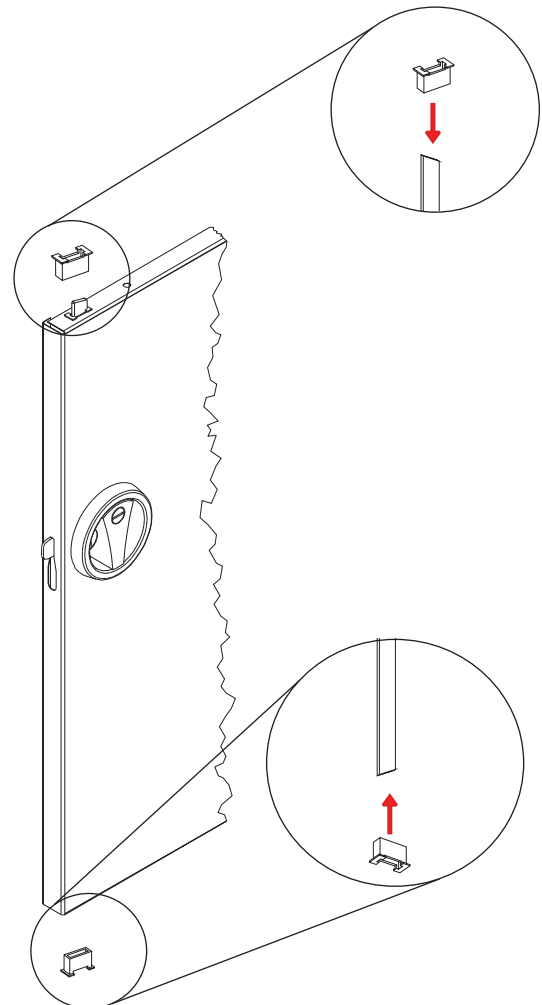

REPLACEMENT PARTS

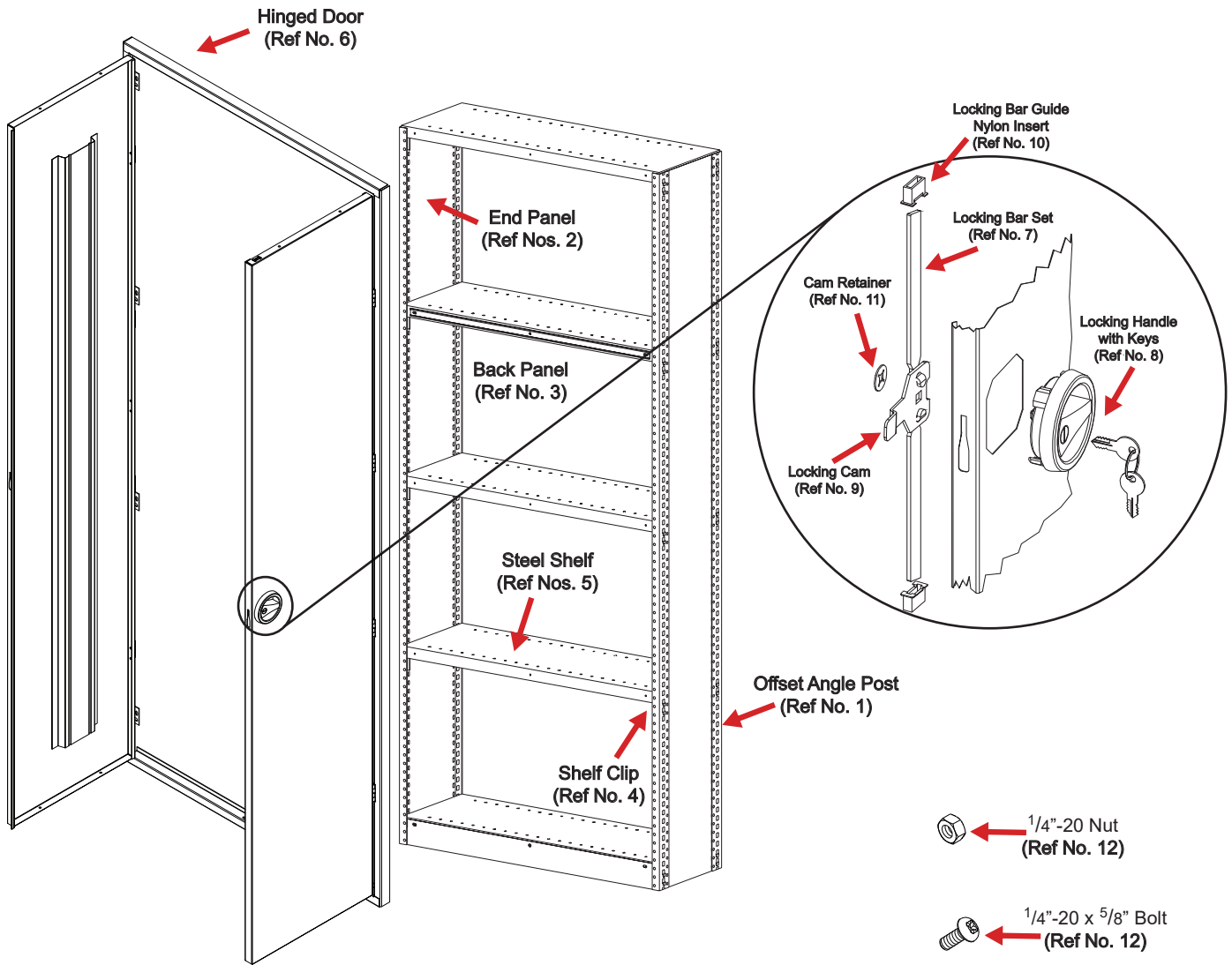

REF. NO.	DESCRIPTION	PART NUMBERS	QTY.
1	Offset Angle Post	OAP-87	4
2	End Panel	EP-1287	2
3	Back Panel	BP-3687	1
4	Shelf Clip	T-1	20
5	22 Gauge Steel Shelf	Q2-36dd	5
6	Hinged Door & Frame Assembly	HD-3687	1
7	Locking Bar Set	944LB	1
8	Recessed Locking Handle w/keys	RH-1	1
9	Locking Cam*	944LC	1
10	Locking Bar Guide Insert*	944GI	2
11	Cam Retainer*	944CR	1
12	1/4"-20 x 5/8" Bolts and Nuts**	--	--

*Included in Ref. No. 8, locking handle with keys and hardware (Part No. RH-1) **Available Locally

Part No. is composed of prefix shown plus a combination of the opening of the unit. ww = Width, dd = Depth & hh = Height. In this case, the depth for the Q2-36dd is going to be either 12, 18 or 24.

NOTE: Additional hardware may be included for replacement purposes.

Tennsco makes every effort to ensure that all units ship complete with all parts and arrive undamaged. However, should your unit contain missing or damaged parts, please contact your purchase location.