

SIDES	BOTTOM
Material: 0.213"-SS316	

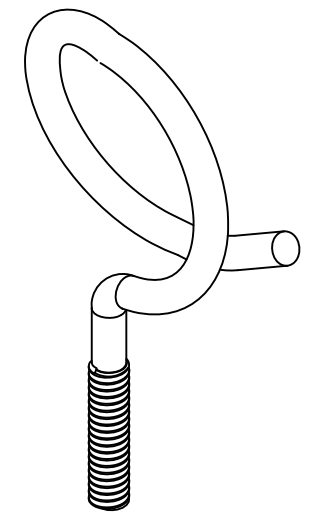
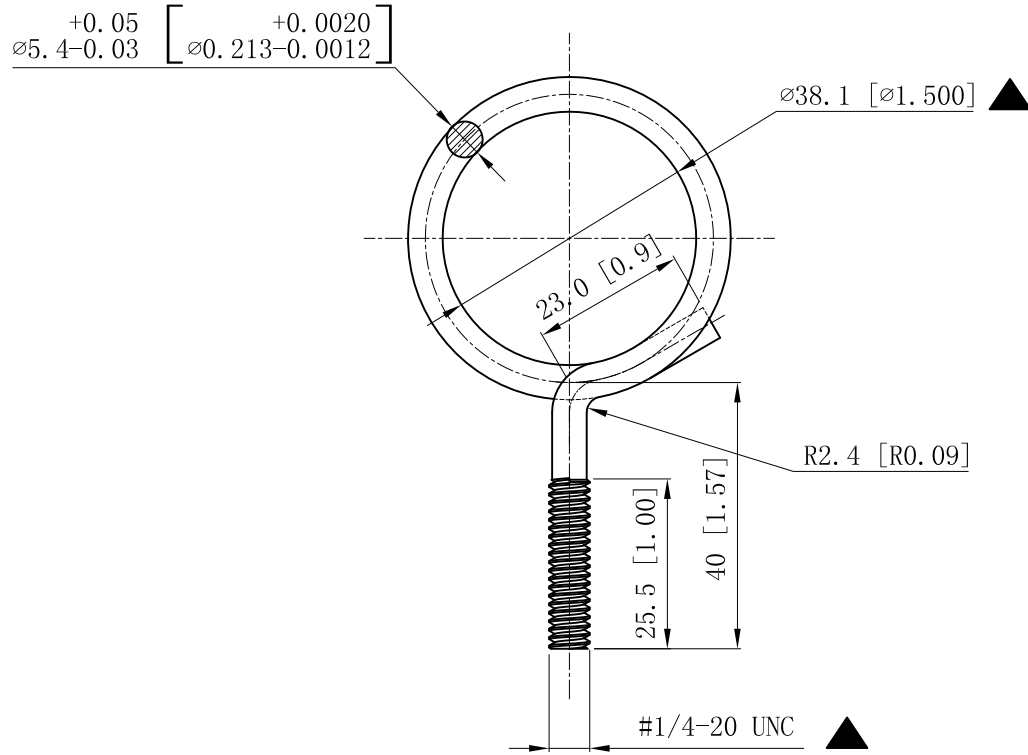

This data sheet is for reference only .GARVIN INDUSTRIES reserves the right to make changes to the design without prior notice.

DESCRIPTION
TRADE REFERENCE TERMS

STANDARD PACKING
100 PCS

GARVIN INDUSTRIES			
TITLE MACHINE-SCREW BRIDLE RINGS			
SIZE A4	DWG NO.	BR-150-SS	REV A
DATA SHEET			
www.garvinindustries.com			