

F23235

BROOKRIDGE PLAY SYSTEM



OBSTACLE FREE SAFETY ZONE - 27' L x 25' 11" D area requires Protective Surfacing.

See page 4.

MAXIMUM VERTICAL FALL HEIGHT - 6'5" (2.1m).

CAPACITY - 9 Users Maximum, Ages 3 - 10; Weight Limit 110 lbs. (49.9 kg) per child.

RESIDENTIAL HOME USE ONLY. Not intended for public areas such as multi-unit residences, schools, churches, nurseries, day cares or parks.

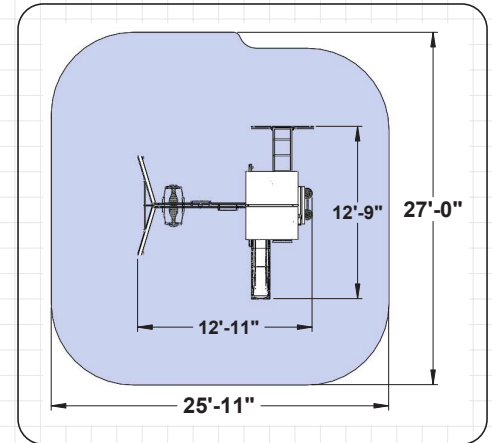

INSTALLATION AND OPERATING INSTRUCTIONS

FOR 24/7 ONLINE PARTS REPLACEMENT

parts.kidkraft.com

KidKraft, Inc.
4630 Olin Road
Dallas, Texas 75244
USA

customerservice@kidkraft.com

1.800.933.0771
972.385.0100

parts.kidkraft.eu

KidKraft Netherlands BV
Olympisch Stadion 8
1076 DE Amsterdam
The Netherlands

europcustomerservice@kidkraft.com

+31 20 305 8620
M-F from 09:00 to 17:30 (GMT+1)

9403235

Rev 10/22/2021



WARNING

To reduce the risk of serious injury or death, please read and follow these instructions. Keep and refer to instructions as needed and pass along to any future owners of this item.

Congratulations on purchasing a KidKraft product! Our items are made of high-quality, durable Cunninghamia Lanceolata wood from the cypress family. Lumber from these trees are known for their light weight and excellent strength. The porosity of this wood allows the moisture to absorb and evaporate in the fibers, resisting rot and bugs. Engineered for great play, our products also go through extensive testing for safety. Plus, our team has developed a series of proprietary methods for a simpler, more organized assembly. Less build time and more play time is our motto! However, during assembly if you have any questions or concerns, please reach out. Our Customer Service can help with missing parts, instructions or maintenance.

Warnings and Safe Play Instructions



CONTINUOUS ADULT SUPERVISION REQUIRED. Most serious injuries and deaths on playground equipment have occurred while children were unsupervised! Our products are designed to meet mandatory and voluntary safety standards. Complying with all warnings and recommendations in these instructions will reduce the risk of serious or fatal injury to children using this play system. Go over the warnings and safe play instructions regularly with your children and make certain that they understand and follow them. Remember on-site adult supervision is required for children of all ages.



WARNING

SERIOUS HEAD INJURY HAZARD

Installation over concrete, asphalt, dirt, grass, carpet and other hard surface creates a risk of serious injury or death from falls to the ground. Install and maintain shock absorbing material under and around play-set as recommended on page 3 of these instructions.

COLLISION HAZARD

Place play-set on level ground at least 2m from any obstruction such as a garage or house, fences, poles, trees, sidewalks, walls, landscape timbers, rocks, pavement, planters, garden borders, overhanging branches, laundry lines, and electrical wires. (See OBSTACLE FREE SAFETY ZONE on cover)

CHOKING HAZARD/SHARP EDGES & POINTS

Adult assembly required. This product contains small parts and parts with sharp edges and points. Keep parts away from children until fully assembled.

WARNING LABEL

Owners shall be responsible for maintaining the legibility of the warning labels.

STRANGULATION HAZARD

- NEVER allow children to play with ropes, clotheslines, pet leashes, cables, chains or cord-like items when using this play-set or to attach these items to play-set.
- NEVER allow children to wear loose fitting clothing, ponchos, hoods, scarves, capes, necklaces, items with draw-strings, cords or ties when using this play-set.
- NEVER allow children to wear bike or sport helmets when using this play-set.

Failure to prohibit these items, even helmets with chin straps, increases the risk of serious injury and death to children from entanglement and strangulation.

TIP OVER HAZARD

Choose a level location for the equipment. This can reduce the likelihood of the play set tipping over and loose-fill surfacing materials washing away during heavy rains.

DO NOT allow children to play on the play-set until the assembly is complete and the unit is properly anchored.

Never add extra length to chain or rope. The chains or ropes provided are the maximum length designed for the swinging element(s).



WARNING – Safe Play Instructions

- ✓ Observe capacity limitations of your play-set. See front cover.
- ✓ Dress children with well fitting and full foot enclosing footwear.
- ✓ Teach children to sit with their full weight in the center of the swing seat to prevent erratic swing motion or falling off.
- ✓ Check for splintered, broken or cracked wood; missing, loose, or sharp edged hardware. Replace, tighten and or sand smooth as required prior to playing.
- ✓ Verify that suspended climbing ropes, rope ladders, chain or cable are secured at both ends and cannot be looped back on itself as to create an entanglement hazard.
- ✓ On sunny and or hot days, check the slide and other plastic rides to assure that they are not very hot as to cause burns. Cool hot slide and rides with water and wipe dry prior to using.
- ✓ Orientate slide such that it gets the least amount of exposure to the sun.
- ✗ Do not allow children to wear open toe or heel footwear like sandals, flip-flops or clogs.
- ✗ Do not allow children to walk, in front, between, behind or close to moving rides.
- ✗ Do not let children twist swing chains or ropes or loop them over the top support bar. This may reduce the strength of the chain or rope and cause premature failure.
- ✗ Do not let children get off rides while they are in motion.
- ✗ Do not permit climbing on equipment when it is wet.
- ✗ Do not permit rough play or use of equipment in a manner for which it was not intended. Standing on or jumping from the roof, elevated platforms, swings, climbers, ladders or slide can be dangerous.
- ✗ Do not allow children to swing empty rides or seats.
- ✗ Do not allow children to go down slide head first or run up slide.

⚠️ Protective Surfacing - Reducing Risk of Serious Head Injury From Falls

One of the most important things you can do to reduce the likelihood of serious head injuries is to install shock-absorbing protective surfacing under and around your play equipment. The protective surfacing should be applied to a depth that is suitable for the equipment height in accordance with ASTM F1292. There are different types of surfacing to choose from; whichever product you select, follow these guidelines:

Loose-Fill Materials

- Maintain a minimum depth of 9 inches (23 cm) of loose-fill materials such as wood mulch/chips, engineered wood fiber (EWF), or shredded/recycled rubber mulch for equipment up to 8 feet (2.45 m) high; and 9 inches (23 cm) of sand or pea gravel for equipment up to 5 feet (1.5 m) high. NOTE: An initial fill level of 12 inches (31 cm) will compress to about a 9-inch (23 cm) depth of surfacing over time. The surfacing will also compact, displace, and settle, and should be periodically raked and refilled to maintain at least a 9-inch (23 cm) depth.
- Use a minimum of 6 inches (16 cm) of protective surfacing for play equipment less than 4 feet (1.22 m) in height. If maintained properly, this should be adequate. (At depths less than 6 inches (16 cm), the protective material is too easily displaced or compacted.)

NOTE: Do not install home playground equipment over concrete, asphalt, or any other hard surface. A fall onto a hard surface can result in serious injury to the equipment user. Grass and dirt are not considered protective surfacing because wear and environmental factors can reduce their shock absorbing effectiveness. Carpeting and thin mats are not adequate protective surfacing. Ground level equipment -- such as a sandbox, activity wall, playhouse or other equipment that has no elevated play surface -- does not need any protective surfacing.

- Use containment, such as digging out around the perimeter and/or lining the perimeter with landscape edging. Don't forget to account for water drainage.
- Periodically rake, check and maintain the depth of the loose-fill surfacing material. Marking the correct depth on the play equipment support posts will help you to see when the material has settled and needs to be raked and or replenished. Be sure to rake and evenly redistribute the surfacing in heavily used areas.
- Do not install loose fill surfacing over hard surfaces such as concrete or asphalt.

Poured-In-Place Surfaces or Pre-Manufactured Rubber Tiles

You may be interested in using surfacing other than loose-fill materials - like rubber tiles or poured-in-place surfaces.

- Installations of these surfaces generally require a professional and are not "do-it yourself" projects.
- Review surface specifications before purchasing this type of surfacing. Ask the installer/manufacturer for a report showing that the product has been tested to the following safety standard: ASTM F1292 *Standard Specification for Impact Attenuation of Surfacing Materials within the Use Zone of Playground Equipment*. This report should show the specific height for which the surface is intended to protect against serious head injury. This height should be equal to or greater than the fall height - vertical distance between a designated play surface (*elevated surface for standing, sitting, or climbing*) and the protective surfacing below - of your play equipment.
- Check the protective surfacing frequently for wear.

Placement

Proper placement and maintenance of protective surfacing is essential. Refer to diagram on front cover. Be sure to;

- Extend surfacing at least 6 feet (1.8 m) from the equipment in all directions.
- For to-fro swings, extend protective surfacing in front of and behind the swing to a distance equal to twice the height of the top bar from which the swing is suspended.
- For tire swings, extend surfacing in a circle whose radius is equal to the height of the suspending chain or rope, plus 6 feet (1.8 m) in all directions.

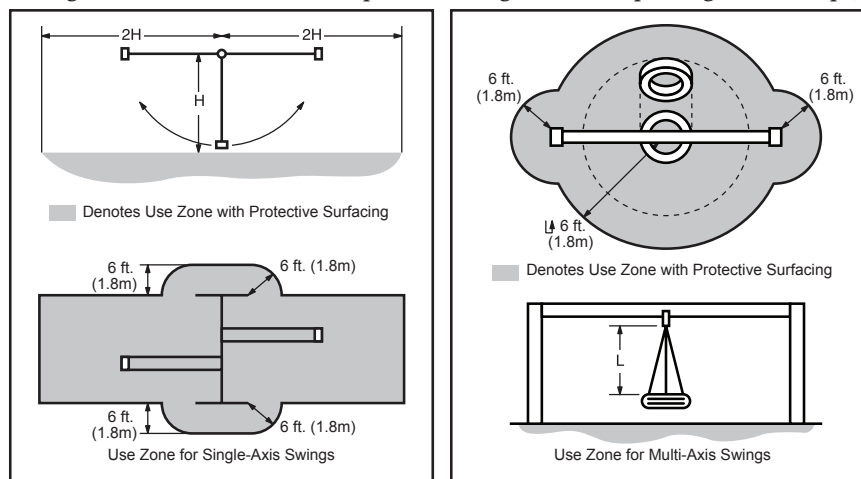

From the CPSC Outdoor Home Playground Safety Handbook. At <http://www.playgroundregs.com/resources/CPSC%20324.pdf>

Instructions for Proper Maintenance

Your KidKraft Play System is designed and constructed of quality materials with your child's safety in mind. As with all outdoor products used by children, it will weather and wear. To maximize the enjoyment, safety and life of your Play Set, it is important that you, the owner, properly maintain it.

Check the following at the beginning of the play season:

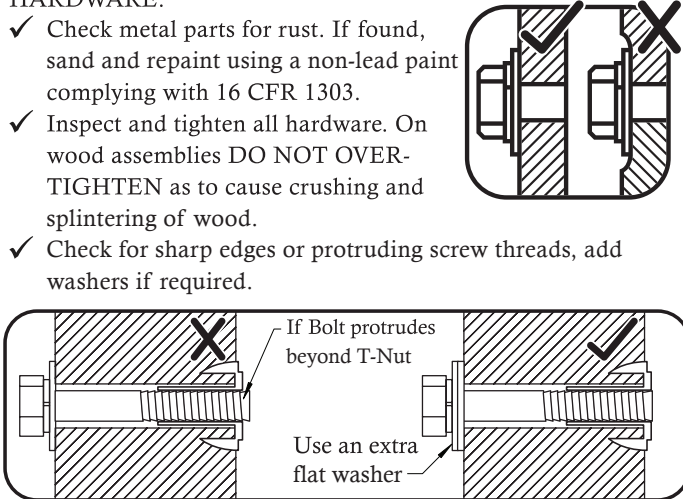
<p>HARDWARE:</p> <ul style="list-style-type: none"> ✓ Check metal parts for rust. If found, sand and repaint using a non-lead paint complying with 16 CFR 1303. ✓ Inspect and tighten all hardware. On wood assemblies DO NOT OVER-TIGHTEN as to cause crushing and splintering of wood. ✓ Check for sharp edges or protruding screw threads, add washers if required.  <p>SHOCK ABSORBING SURFACING:</p> <ul style="list-style-type: none"> ✓ Check for foreign objects. Rake and check depth of loose fill protective surfacing materials to prevent compaction and maintain appropriate depth. Replace as necessary. (See Protective Surfacing, page 3) 	<p>GROUND STAKES (ANCHORS):</p> <ul style="list-style-type: none"> ✓ Check for looseness, damage or deterioration. Should firmly anchor unit to ground during use. Re-secure and or replace, if necessary. <p>SWING HANGERS:</p> <ul style="list-style-type: none"> ✓ Check that bolts are secure and tight. Quick clips should be completely closed and threaded clips screwed tight. ✓ If squeaking occurs lubricate bushings with oil or WD-40®. <p>SWINGS, ROPES AND RIDES:</p> <ul style="list-style-type: none"> ✓ Reinstall if removed during cold season. Check all moving parts including swing seats, ropes, chains and attachments for wear, rust and other deterioration. Replace as needed. ✓ Check that ropes are tight, secure at both ends and cannot loop back as to create an entrapment. <p>WOOD PARTS:</p> <ul style="list-style-type: none"> ✓ Check all wood members for deterioration, structural damage and splintering. Sand down splinters and replace deteriorated wood members. As with all wood, some checking and small cracks in grain is normal. ✓ Applying a water repellent or stain (water-based) on a yearly basis is important maintenance to maintain maximum life and performance of the product.
--	---

Check twice a month during play season:

<p>HARDWARE:</p> <ul style="list-style-type: none"> ✓ Inspect for tightness. Must be firmly against, but not crushing the wood. DO NOT OVER-TIGHTEN. This will cause splintering of wood. ✓ Check for sharp edges or protruding screw threads. Add washers if required. 	<p>SHOCK ABSORBING SURFACING:</p> <ul style="list-style-type: none"> ✓ Rake and check depth of loose fill protective surfacing materials to prevent compaction and maintain appropriate depth. Replace as necessary. (See Protective Surfacing, page 3)
---	---

Check once a month during play season:

<p>SWING HANGERS:</p> <ul style="list-style-type: none"> ✓ Check that they are secure and orientated correctly. Hook should rotate freely and perpendicular to support beam. ✓ If squeaking occurs lubricate bushings with oil or WD-40®. 	<p>SWINGS AND RIDES:</p> <ul style="list-style-type: none"> ✓ Check swing seats, all ropes, chains and attachments for fraying, wear, excessive corrosion or damage. Replace if structurally damaged or deteriorated.
--	---

Check at the end of the play season:

<p>SWINGS AND RIDES:</p> <ul style="list-style-type: none"> ✓ To prolong their life, remove swings and store inside when outside temperature is below 32°F/0°C. Below freezing, plastic parts may become more brittle. 	<p>SHOCK ABSORBING SURFACING:</p> <ul style="list-style-type: none"> ✓ Rake and check depth of loose fill protective surfacing materials to prevent compaction and maintain appropriate depth. Replace as necessary. (See Protective Surfacing, page 3)
--	---

If you dispose of your play set: Please disassemble and dispose of your unit so that it does not create any unreasonable hazards at the time it is discarded. Be sure to follow your local waste ordinances.

About Our Wood

KidKraft Premium Play Systems uses only premium playset lumber, ensuring the safest product for your children's use. Although we take great care in selecting the best quality lumber available, wood is still a product of nature and susceptible to weathering which can change the appearance of your set.

What causes weathering? Does it affect the strength of my Play System?

One of the main reasons for weathering is the effects of water (moisture); the moisture content of the wood at the surface is different than the interior of the wood. As the climate changes, moisture moves in or out of the wood, causing tension which can result in checking and or warping. You can expect the following due to weathering. These changes will not affect the strength of the product:

1. **Checking** is surface cracks in the wood along the grain. A post 4" x 4" (101mm x 101mm) will experience more checking than a board 1" x 4" (25mm x 101mm) because the surface and interior moisture content will vary more widely than in thinner wood.
2. **Warping** results from any distortion (twisting, cupping) from the original plane of the board and often happens from rapid wetting and drying of the wood.
3. **Fading** happens as a natural change in the wood color as it is exposed to sun-light and will turn a grey over time.

How can I reduce the amount of weathering to my Play System?

At the factory we have coated the wood with a water repellent or stain. This coating decreases the amount of water absorption during rain or snow thus decreasing the tension in the wood. Sunlight will break down the coating, so we recommend applying a water repellent or stain on a yearly basis (see your local stain and paint supplier for a recommended product).

Most weathering is just the normal result of nature and will not affect safe play and enjoyment for your child. However if you are concerned that a part has experienced a severe weathering problem please call our consumer relations department for further assistance.

Complete and mail registration card to receive important product notifications and assure prompt warranty service.

KidKraft Limited Warranty

MISSING OR DAMAGED PARTS:

KidKraft will replace any parts within 90 days from date of purchase found to be missing from or damaged in the original packaging. See Fig.1

Fig. 1	<u>Product Age (All Parts)</u> 0-90 Days from date of purchase	<u>Consumer Pays</u> \$0 for Part + Free Shipping
--------	---	--

DEFECTS IN MATERIAL AND WORKMANSHIP:

KidKraft warrants that this product is free from defects in materials and workmanship for a period of one (1) year from the original date of purchase (dated sales receipt and/or product registration is required). This one (1) year warranty covers all parts including wood, hardware, and all accessories (Such as swings, rides, and slides). See Fig. 2

Fig. 2	<u>Product Age (All Parts)</u> 91 Days to 1 Year	<u>Consumer Pays</u> \$0 for Part + Free Shipping
--------	---	--

WOOD ROT, DECAY, AND INSECT DAMAGE:

All wood carries a five (5) year warranty against rot, decay, and insect damage (dated sales receipt and/or product registration is required). Refer to the schedule below for charges associated with replacement of wood parts under this **Limited Warranty**. See Fig. 3

Fig. 3	<u>Product Age (Wood Parts)</u> 0 Days to 1 Year After 1 Year to 5 Year Over 5 Years	<u>Consumer Pays</u> \$0 for Part + Free Shipping \$0 for Part + Shipping & Handling 100% for Part (if available) + Shipping & Handling
--------	---	--

This warranty applies to the original owner and registrant and is non-transferable. Regular maintenance is required to ensure the integrity of this product. Failure by the owner to maintain the product according to the maintenance requirements may void this warranty.

This Limited Warranty does NOT cover:

- Any inspection cost
- Labor and/or costs for replacement of any defective item(s), including but not limited to, professional installer costs
- Incidental or consequential damages, including but not limited to, as a result of set relocation, move and/or reinstall
- Cosmetic defects which do not affect performance or integrity of a part or the entire product
- Vandalism, improper use or installation, or acts of nature, including but not limited to, high winds, fire, and flood
- Minor twisting, warping, checking, or any natural occurring properties of wood that do not affect performance or integrity.
- Any KidKraft product purchased, including but not limited to, a non-approved retailer, auction houses, second-hand, and as-is clearance items.

KidKraft products have been designed for safety and quality. Modifications made to the original product may damage the structural integrity of the unit leading to failure and possible injury. KidKraft cannot assume any responsibility for the modified products. Furthermore, modifications void all warranties.

This product is warranted for **RESIDENTIAL USE ONLY**. Under no circumstance should a KidKraft product be used in public settings such as schools, churches, playgrounds, parks, home and professional day cares and the like. Such use may lead to product failure and potential injury. Public use will void this warranty. KidKraft disclaims all other representations and warranties of any kind, express or implied.

Keys to Assembly Success

Tools Required

<ul style="list-style-type: none"> • Tape Measure • Carpenters Level • Carpenters Square • Claw Hammer • Standard or Cordless Drill • Rubber Mallet 	<ul style="list-style-type: none"> • #1 Phillips, #2 Robertson and Screwdriver • Ratchet with extension 1/2" (13mm) & 9/16" (14 mm) sockets 	<ul style="list-style-type: none"> • Open End Wrench 1/2" (13mm) & 9/16" (14 mm) • Adjustable Wrench • 1/8" (3mm) & 3/16" (5mm) Drill Bits 	<ul style="list-style-type: none"> • 3/16" (5mm) Hex Key • 8' (2.4m) Step Ladder • Safety Glasses • Adult Helpers • Pencil
---	---	---	---

Part Identification Key

On each page, you will find the parts and quantities required to complete the assembly step illustrated on that page. Here is a sample.

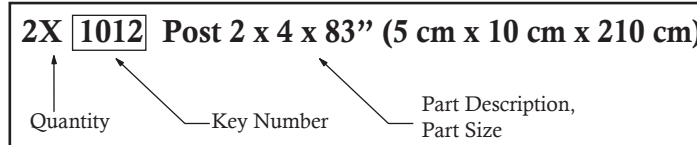

Symbols

Throughout these instructions symbols are provided as important reminders for proper and safe assembly.

<p>This identifies information that requires special attention. Improper assembly could lead to an unsafe or dangerous condition.</p>	<p>Check that set or assembly is properly level before proceeding.</p> <p>Use Level</p>
<p>Use Help</p> <p>Where this is shown, 2 or 3 people are required to safely complete the step. To avoid injury or damage to the assembly make sure to get help!</p>	<p>Pre-drill 1/8" (3mm) & 3/16" (5mm) Bit</p> <p>Pre-drill a pilot hole before fastening screw or lag to prevent splitting of wood.</p>
<p>Measure Distance</p> <p>Use a measuring tape to assure proper location.</p>	<p>Tighten Bolts</p> <p>This indicates time to tighten bolts, but not too tight! Do not crush the wood. This may create splinters and cause structural damage.</p>
<p>Check that assembly is square before tightening bolts.</p> <p>Square Assembly</p>	

CAUTION – Protrusion Hazard

Once the assembly is tightened, watch for exposed threads. If a thread protrudes from the T-Nut, remove the bolt and add washers to eliminate this condition. Extra washers have been provided for this purpose.

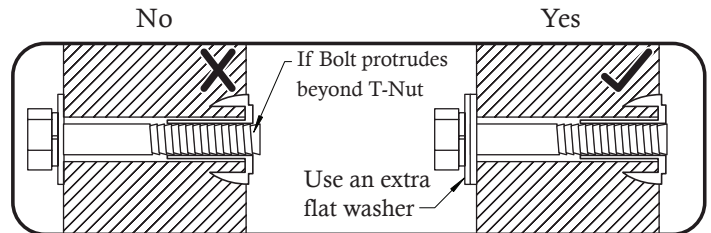

Proper Hardware Assembly

Lag screws require drilling pilot holes to avoid splitting wood. Only a flat washer is required. For ease of installation liquid soap can be used on all lag-type screws.

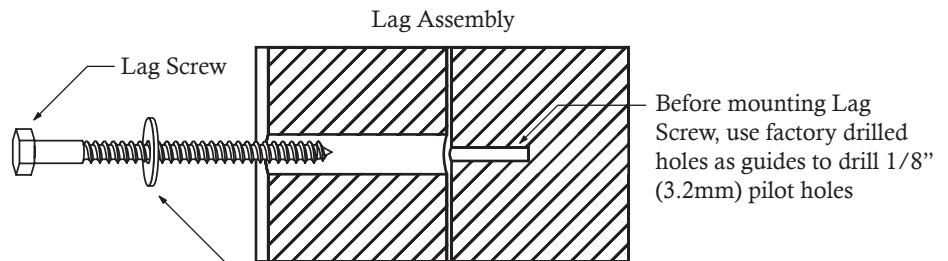

For bolts, tap T-Nut into hole with hammer. Insert the hex bolt through lock washer first then flat washer then hole. Because the assemblies need to be squared do not completely tighten until instructed. Pay close attention to diameter of the bolts. 5/16" (8mm) is slightly larger than 1/4" (6.4mm).

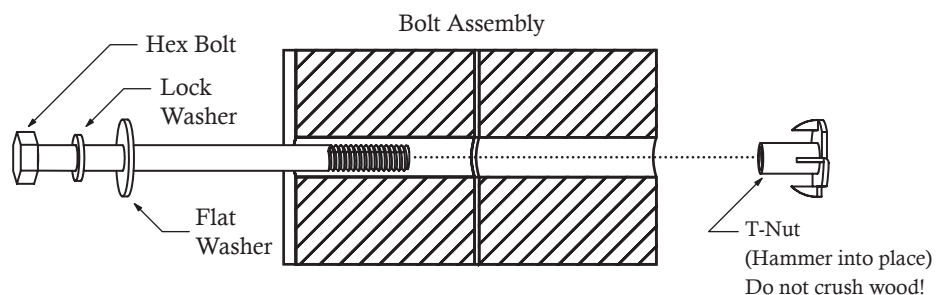

Note: Wafer head bolts with blue lock tight or a bolt with a Ny-Lok nut do NOT require a lock washer.

Part Identification (Reduced Part Size)

Nominal Size	Actual Size
1/2 x 4	7/16" x 3 1/4"
1 x 2	5/8" x 1 3/8"
1 x 4	5/8" x 3 3/8"
1 x 5	5/8" x 4 1/2"

12pc. - **1503** - Wall Board 1/2 x 4 x 20" - 3631503- Box 2



1pc. - **1944** - Panel Frame 1 x 2 x 24 3/8" - 3641944 - Box 2



1pc. - **1227** - CE Wall Board 1 x 4 x 20" - 3631227 - Box 2



2pc. - **2034** - Wall Support 1 x 4 x 35 7/8" - 3642034 - Box 2

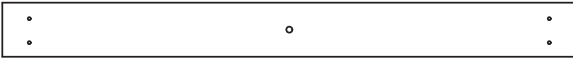

1pc. - **1906** - Top Front Back 1 x 4 x 38 1/2" - 3641906 - Box 2



2pc. - **1909** - Tarp Front Back 1 x 4 x 46 3/4" - 3641909- Box 2



1pc. - **9532** - MK Ground 5/8 x 3 3/8 x 52 1/2" - 3639532 - Box 2



2pc. - **2030** - Side Roof 1 x 4 x 58 1/2" - 3642030 - Box 2



1pc. - **1895** - Floor End 1 x 5 x 35 1/4" - 3641895 - Box 2

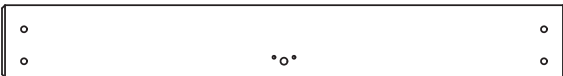

1pc. - **2032** - End Floor 1 x 5 x 35 1/4" - 3642032 - Box 2

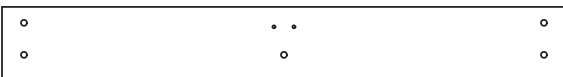

1pc. - **2036** - Cafe Ground 1 x 5 x 35 7/8" - 3642036 - Box 2



2pc. - **1768** - Lower Back 1 x 5 x 38 1/2" - 3641768 - Box 2



1pc. - **2037** - Front Top 1 x 5 x 38 1/2" - 3642037 - Box 2



1pc. - **2029** - Ground SW 1 x 5 x 72" - 3642029 - Box 2



Part Identification (Reduced Part Size)

Nominal Size	Actual Size
1 x 6	5/8" x 5 5/8"
5/4 x 3	1" x 2 1/2"
5/4 x 4	1" x 3 1/2"
2 x 2	1 1/2" x 1 1/2"

2pc. - **1779** - CE Access Board 1 x 6 x 17" - 3631779 - Box 2



2pc. - **1778** - CE Rock Board A 1 x 6 x 17" - 3631778 - Box 2



3pc. - **1777** - CE Rock Board B 1 x 6 x 17" - 3631777 - Box 2



2pc. - **1890** - CE Gap Board 1 x 6 x 32 1/2" - 3631890 - Box 2



5pc. - **1889** - Floor Board 1 x 6 x 32 1/2" - 3631889 - Box 2



6pc. - **0318** - Ground Stake 1 1/4 x 1 1/2 x 14" - 3650318 - Box 1

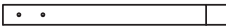

1pc. - **1903** - Floor Joist 5/4 x 3 x 38 1/2" - 3641903 - Box 2



1pc. - **2028** - Cafe Top 5/4 x 4 x 35 7/8" - 3632028 - Box 2

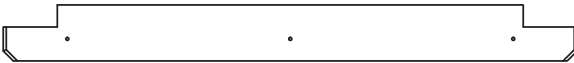

1pc. - **1894** - Back Floor 5/4 x 4 x 38 1/2" - 3641894 - Box 2

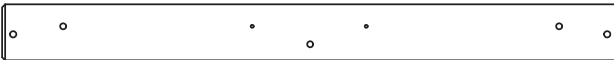

1pc. - **1862** - SW Support 5/4 x 4 x 46 1/2" - 3641862 - Box 2

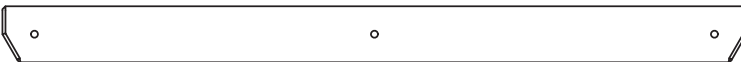

1pc. - **1937** - Centre Divider 2 x 2 x 31 3/4" - 3641937 - Box 2



1pc. - **1761** - Side Joist 2 x 2 x 34 3/4" - 3641761 - Box 2

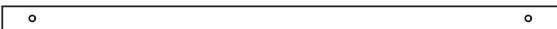

1pc. - **1941** - Water Sand Support 2 x 2 x 35 7/8" - 3641941 - Box 2



Part Identification (Reduced Part Size)

Nominal Size	Actual Size
2 x 2	1½" x 1½"
2 x 3	1¾" x 2½"
2 x 4	1¾" x 3¾"
2 x 6	1½" x 5¾"

1pc. - **1900** - Ridge 2 x 2 x 46 3/4" - 3641900 - Box 2



1pc. - **2031** - Roof Support 2 x 2 x 57 1/8" - 3642031 - Box 2



1pc. - **0312** - Gusset 2 x 3 x 16" - 3640312 - Box 2



1pc. - **2033** - MK Mount 2 x 3 x 35" - 3642033 - Box 2



4pc. - **0369** - Lower Diagonal 2 x 3 x 37" - 3640369 - Box 2

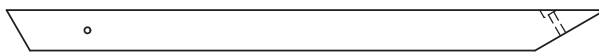

1pc. - **1908** - Front Floor 2 x 3 x 38 1/2" - 3641908 - Box 2

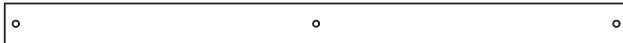

2pc. - **0349** - Rock Rail 2 x 3 x 51" - 3640349 - Box 2



2pc. - **9530** - Post MK 1 3/8 x 2 1/2 x 66 5/8" - 3639530 - Box 2



1pc. - **4919** - SW Rail Block 2 x 4 x 5 3/8" - 3644919 - Box 2



1pc. - **1856** - SW Upright 2 x 4 x 48 5/16" - 3641856 - Box 2



1pc. - **9531** - MK Rail Short 2 x 4 x 50" - 3639531 - Box 2



1pc. - **9533** - MK Rail Long 2 x 4 x 54" - 3639533 - Box 2



1pc. - **2035** - SW Mount 2 x 4 x 59 1/2" - 3642035 - Box 2

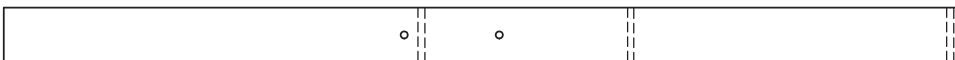

4pc. - **1931** - Post 2 x 4 x 81" - 3641931 - Box 2

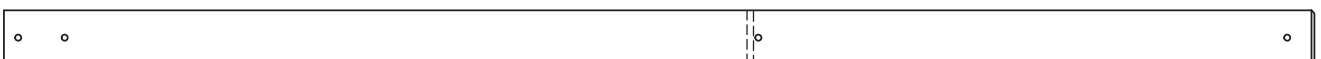

Part Identification (Reduced Part Size)

	Nominal Size	Actual Size
2pc. - 1863 - SW Post 2 x 4 x 86 11/16" - 3641863 - Box 2	2 x 4	1 3/8" x 3 3/8"
1pc. - 1825 - Back Beam 2 x 6 x 83 5/8" - 3631825 - Box 2	2 x 6	1 1/2" x 5 3/8"
1pc. - 1826 - Front Beam 2 x 6 x 83 5/8" - 3631826 - Box 2		

1X 9320374
KidKraft I.D
Plaque

2X 3200184
Triangle Plate (4pk)
Green

1X 3533860
39" Glider Rope & Chain
(4pk) w. welded chain

1X 3320386 Rocks (5pk)
3-Green 2-Yellow

1X 9200140
MB Mount Strap
Green

1X 9200300
MK Bracket
Green

1X 3201307
Monkey Bracket Set

4 x 3200127
Metal Monkey Bar

1X 3320190
Stool Seat Set (2 Yel Seats,
2 Gr. Steel Supports, Steel Brace)

2X 3724943
42" Belt Swing Yellow
w.welded chain

2X 3320172
2 person Glider End

1X 3320273
2 person Glider Seat
Yellow

1X 3200164
Corner Brace Set
(4pk) Green

1X 9750120
Chalk Wall/Tarp
Green

1 x 9750235
Brookridge
Canopy Gr./Yel.

1X 9750237
Cafe Canopy
Green/Yellow

1 x 9750236
Brookridge Tarps
Green/Yellow

1X 3750235
Brookridge Canopy Set

1X 9200840
Greenbrook Cafe
Frame - Green

1X 3200202
Glider Hanger (2pk)

1X 3310149
Slide 48" High Rail -Green

1X 3320161
Telescope
Green/Yellow

Hardware Identification (Actual Size)

4pc. **LS1** -Lag Screw 1/4 x 1 1/2" - (9262212)

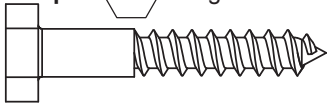

3pc. **LS2** -Lag Screw 1/4 x 2 1/2" - (9272222)



6pc. **LS3** -Lag Screw 1/4 x 3" - (9262230)

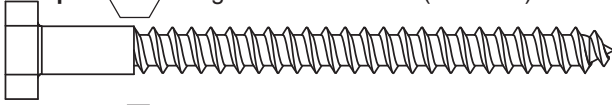

24pc. **H2** -Hex Bolt 1/4 x 2" - (9277220)

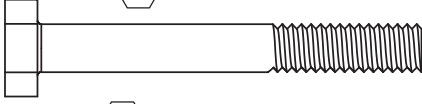

8pc. **WL5** - Wafer Lag 1/4 x 2-1/2" - (52613222)

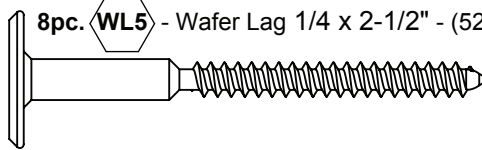

2pc. **H3** -Hex Bolt 1/4 x 2 1/2" - (9277222)

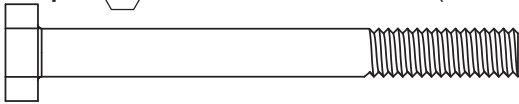

4pc. **H12** -Hex Bolt 1/4 x 3 - (9277230)

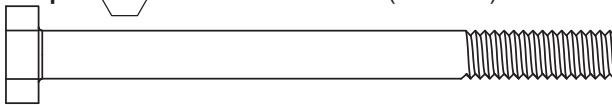

1pc. **H13** -Hex Bolt 1/4 x 3 1/2" - (9277232)

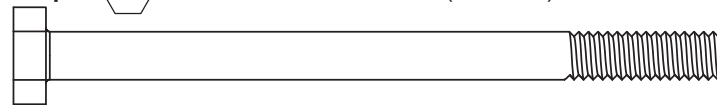

1pc. **H8** -Hex Bolt 1/4 x 4 1/4" - (9277241)

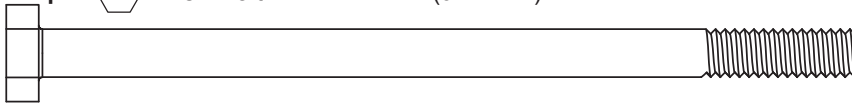

2pc. **H5** -Hex Bolt 1/4 x 4 1/2" - (9277242)

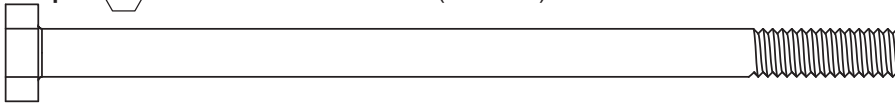

2pc. **H6** -Hex Bolt 1/4 x 4 3/4" - (9277243)

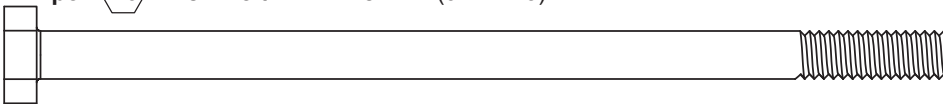

4pc. **H7** -Hex Bolt 1/4 x 5 1/2" - (9277252)

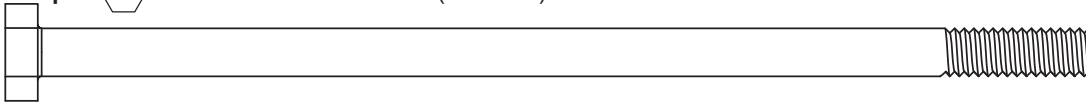

4pc. **G2** -Hex Bolt 5/16 x 1" - (9277310)

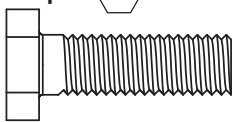

4pc. **G1** -Hex Bolt 5/16 x 1 1/2" - (9277312)

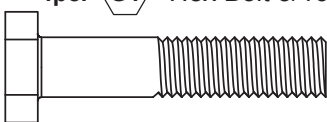

12pc. **G8** -Hex Bolt 5/16 x 2" - (9277320)

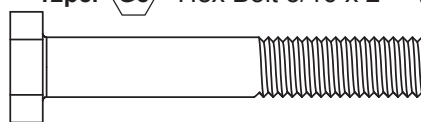

1pc. **G10** -Hex Bolt 5/16 x 3" - (9277330)

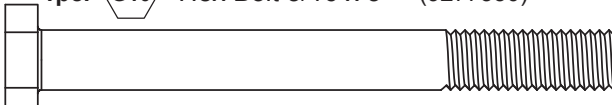

5pc. **G4** -Hex Bolt 5/16 x 4" - (9277340)

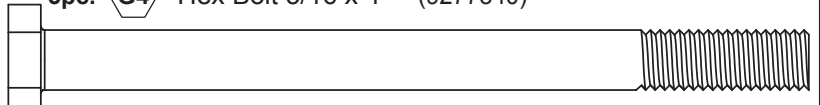

1X 3202000
Swing Hanger Bolt
Thru. (4 pk)

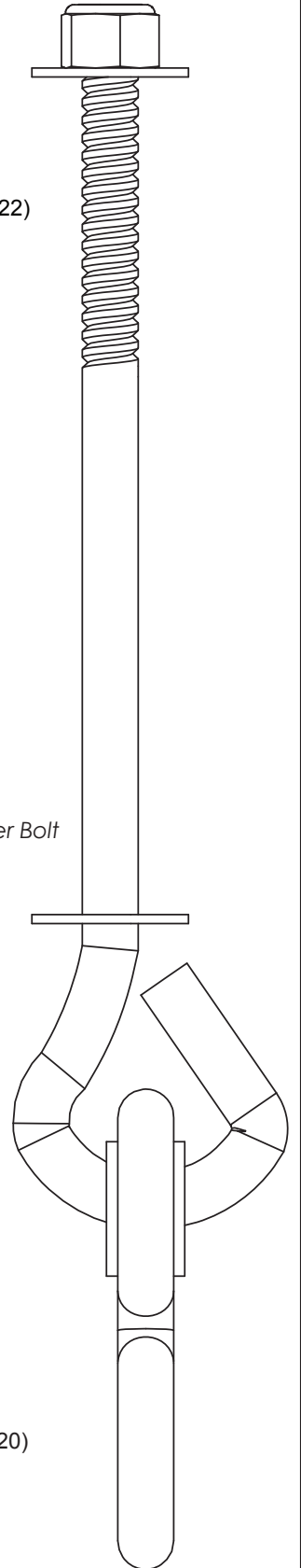

Hardware Identification (Actual Size)

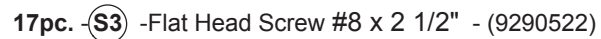
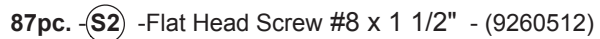
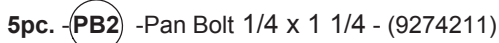
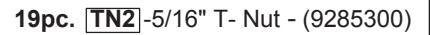
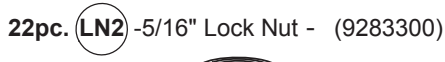
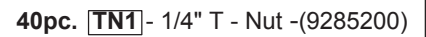
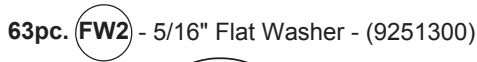
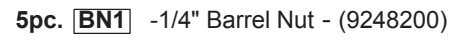
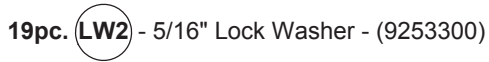
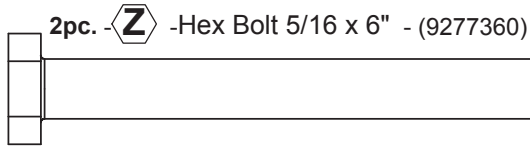
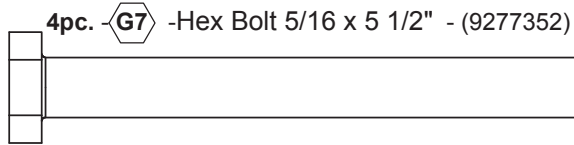
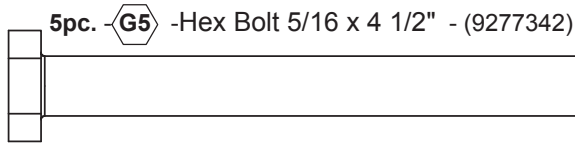

Step 1: Inventory Parts - Read This Before Starting Assembly

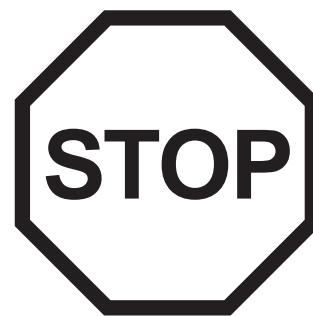
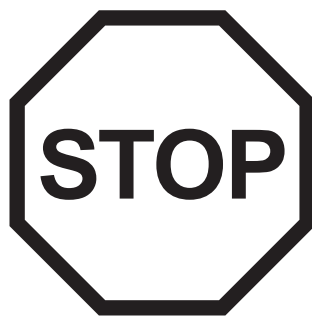
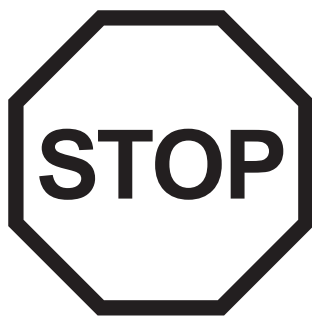
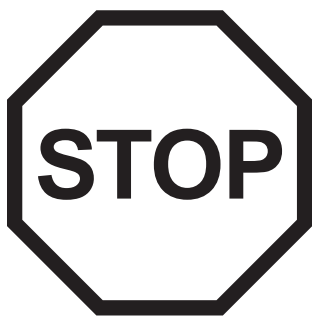

A. This is the time for you to inventory all your hardware, wood and accessories, referencing the parts identification sheets. This will assist you with your assembly.

- The wood pieces will have the key number stamped on the ends of the boards. Organize the wood pieces by step, as per the key numbering system below.

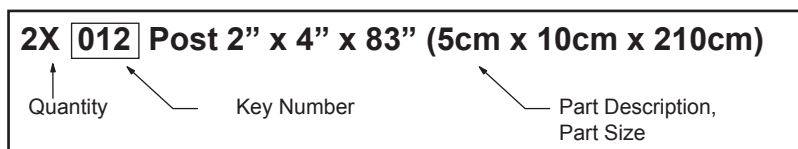

- Please refer to Page 8 for proper hardware assembly.
- Each step indicates which bolts and/or screws you will need for assembly, as well as any flat washers, lock washers, t-nuts or lock nuts.

B. If there are any missing or damaged pieces or you need assistance with assembly please contact the consumer relations department directly. Call us before going back to the store.

1.800.933.0771 or 972.385.0100
customerservice@kidkraft.com
canadacustomerservice@kidkraft.com
For online parts replacement visit
<https://parts.kidkraft.com/>

+31 20 305 8620
europcustomerservice@KidKraft.com
For online parts replacement visit
<https://parts.kidkraft.eu/>

C. Read the assembly manual completely, paying special attention to ANSI warnings; notes; and safety/maintenance information on pages 1 - 8.

D. Before you discard your cartons fill out the form below.

- The Batch # is located on the end of each carton. The tracking number is located on the KidKraft ID Plaque (9320374).
- Please retain this information for future reference. You will need this information if you contact the Consumer Relations Department.

MODEL NUMBER: **F23235**

Batch #: _____ (Box 1)

Batch #: _____ (Box 4)

Batch #: _____ (Box 2)

Batch #: _____ (Box 5)

Batch #: _____ (Box 3)

Batch #: _____ (Box 6)

TRACKING NUMBER (from ID Plaque): _____

Step 2: Rock Wall Assembly



Fig. 2.1

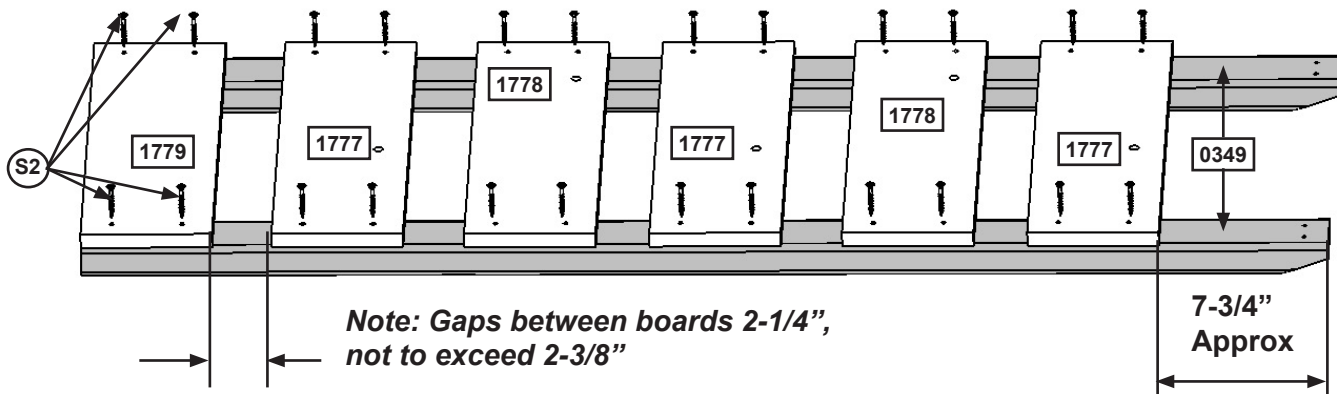

A: Lay 2 (0349) Rock Rails down, side by side with angled edges facing down. (fig. 2.1)

B: Place (1779) CE Access Board on the bottom of each (0349) Rock Rail as shown in fig. 2.1. Make sure (1779) CE Access Board is flush to the outside and bottom edges of each (0349). Attach using 4 (S2) #8 x 1-1/2" Wood Screws.

C: 7-3/4" down from the top of both (0349) Rock Rails place 1 (1777) CE Rock Board B, making sure the sides are flush to the outside edges of each (0349) Rock Rail. Attach using 4 (S2) #8 x 1-1/2" Wood Screws. (fig. 2.1)

D: In between the (1779) CE Access Board and (1777) CE Rock Board B stagger 2 (1778) and 2 (1777) CE Rock Boards A & B using 4 (S2) #8 x 1-1/2" Wood Screws per board. Placing them as shown in fig. 2.1, this will prevent rocks from forming a straight line. Make sure the boards are evenly spaced and do not exceed 2-3/8" between boards.

Fig. 2.2

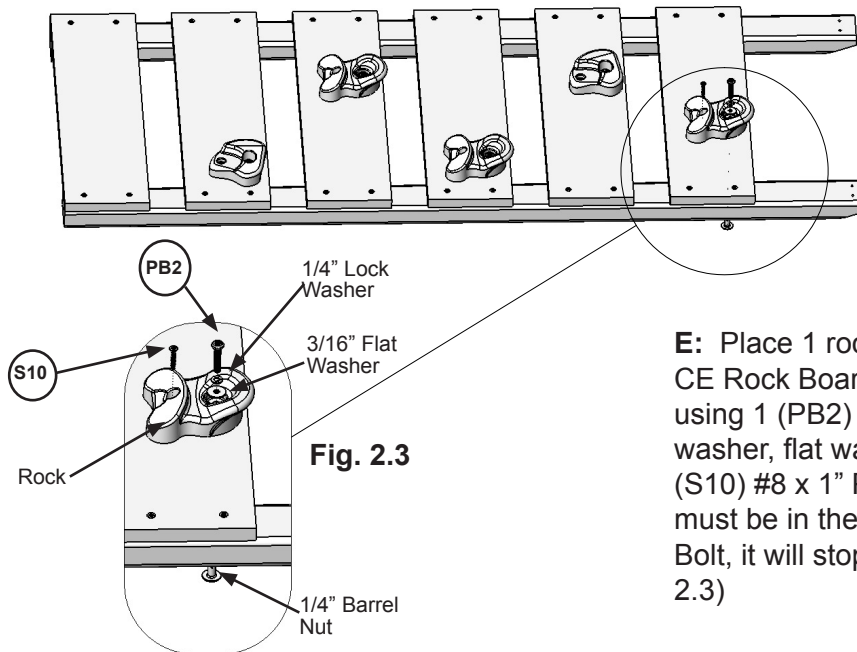

E: Place 1 rock on each (1777) and (1778) CE Rock Board A & B (fig. 2.2) and attach using 1 (PB2) 1/4 x 1-1/4" Pan Bolt (with lock washer, flat washer and barrel nut) and 1 (S10) #8 x 1" Pan Screw per rock. The Screw must be in the hole directly under the Pan Bolt, it will stop the rock from spinning. (fig. 2.3)

Wood Parts

- 1 x 1779 CE Access Board 1 x 6 x 17"
- 3 x 1777 CE Rock Board B 1 x 6 x 17"
- 2 x 1778 CE Rock Board A 1 x 6 x 17"
- 2 x 0349 Rock Rail 2 x 3 x 51"

Hardware

- 24 x S2 #8 x 1-1/2" Wood Screw
- 5 x S10 #8 x 1" Pan Screw
- 5 x PB2 1/4 x 1-1/4 Pan Bolt (1/4" lock washer, 3/16" flat washer & 1/4" barrel nut)

Other Parts

- 5 x Rocks (3 green/2 yellow)

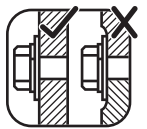

Step 3: Swing Beam Assembly

Fig. 3.4

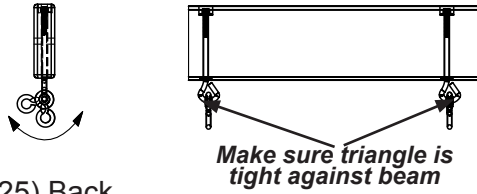

Warning: For your child's safety, orientate the swing hangers as shown to ensure your swing will have proper swing motion when installed. Failure to do so could result in premature failure of the swing hanger or swing chain.

A: In the middle holes of (1825) Back Beam install 2 Bolt-Thru Swing Hangers (fig. 3.1) making sure the swing hangers are oriented in the direction shown in fig. 3.4 to maintain proper swing motion.

B: In the end holes of (1826) Front Beam install 2 Bolt-Thru Swing Hangers (fig. 3.1) making sure the swing hangers are oriented in the direction shown in fig. 3.4 to maintain proper swing motion.

Bolt-Thru Swing Hangers

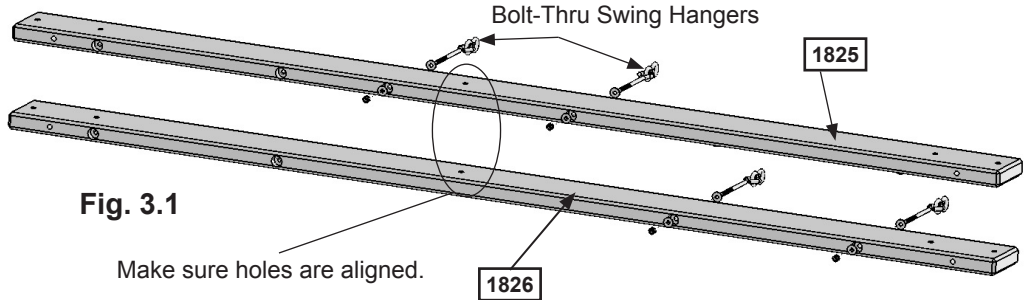
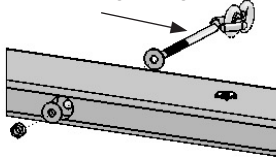

Fig. 3.1

C: Attach 1 Triangle Plate to the ends of each (1826) Front Beam and (1825) Back Beam using 1 (G1) 5/16 x 1-1/2" Hex Bolt (with lock washer, flat washer and t-nut) in the hole indicated in fig. 3.2 & 3.3. **Correct hole usage is very important.**

Fig. 3.2

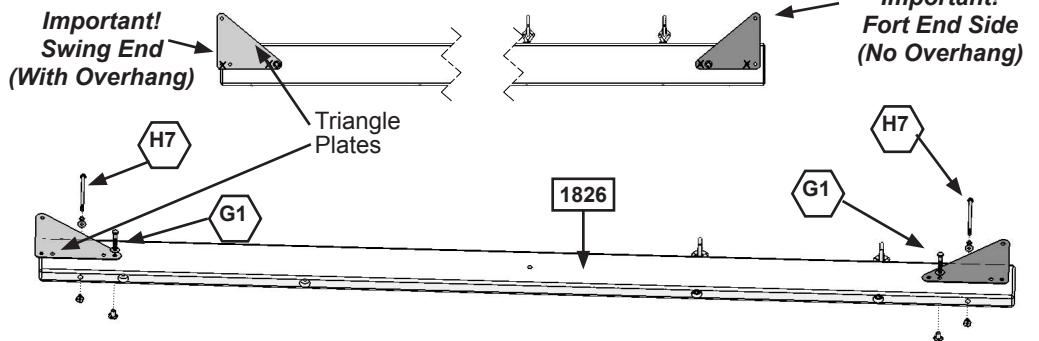
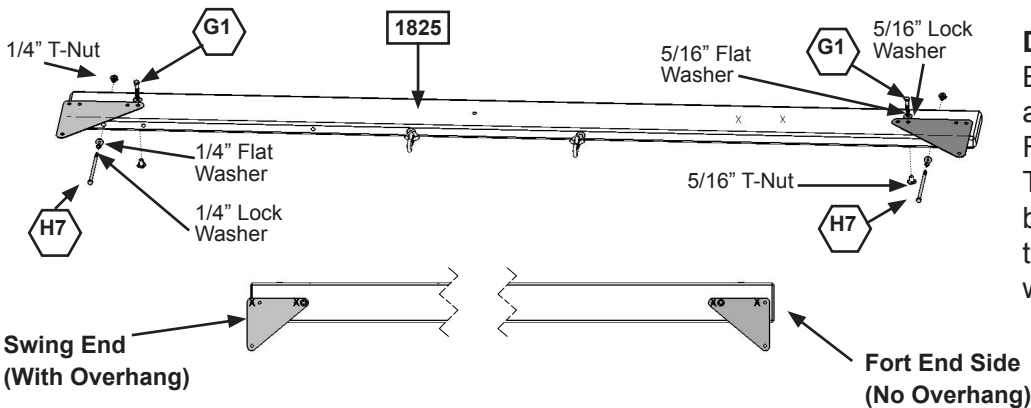

Fig. 3.3



D: Attach 1 (H7) 1/4 x 5-1/2" Hex Bolt (with lock washer, flat washer and t-nut) to the ends of each (1826) Front Beam and (1825) Back Beam. The bolts do not attach to anything, but **MUST** be installed to the beams to prevent splitting and checking of wood. (fig. 3.2 & 3.3)

Wood Parts

- 1 x 1826 Front Beam 2 x 6 x 83-5/8"
- 1 x 1825 Back Beam 2 x 6 x 83-5/8"

Hardware

- 4 x H7 1/4 x 5-1/2" Hex Bolt (1/4" lock washer, 1/4" flat washer, 1/4" t-nut)
- 4 x G1 5/16 x 1-1/2" Hex Bolt (5/16" lock washer, 5/16" flat washer, 5/16" t-nut)

Other Parts

- 1 x Bolt-Thru Swing Hangers (pkg of 4)
- 1 x Triangle Plate (pkg of 4)



Step 4: Swing End Assembly

A: Attach 2 (1863) SW Posts to (1856) SW Upright using 2 (G4) 5/16 x 4" Hex Bolts (with lock washer, flat washer and t-nut). (fig. 4.1)

Fig. 4.1

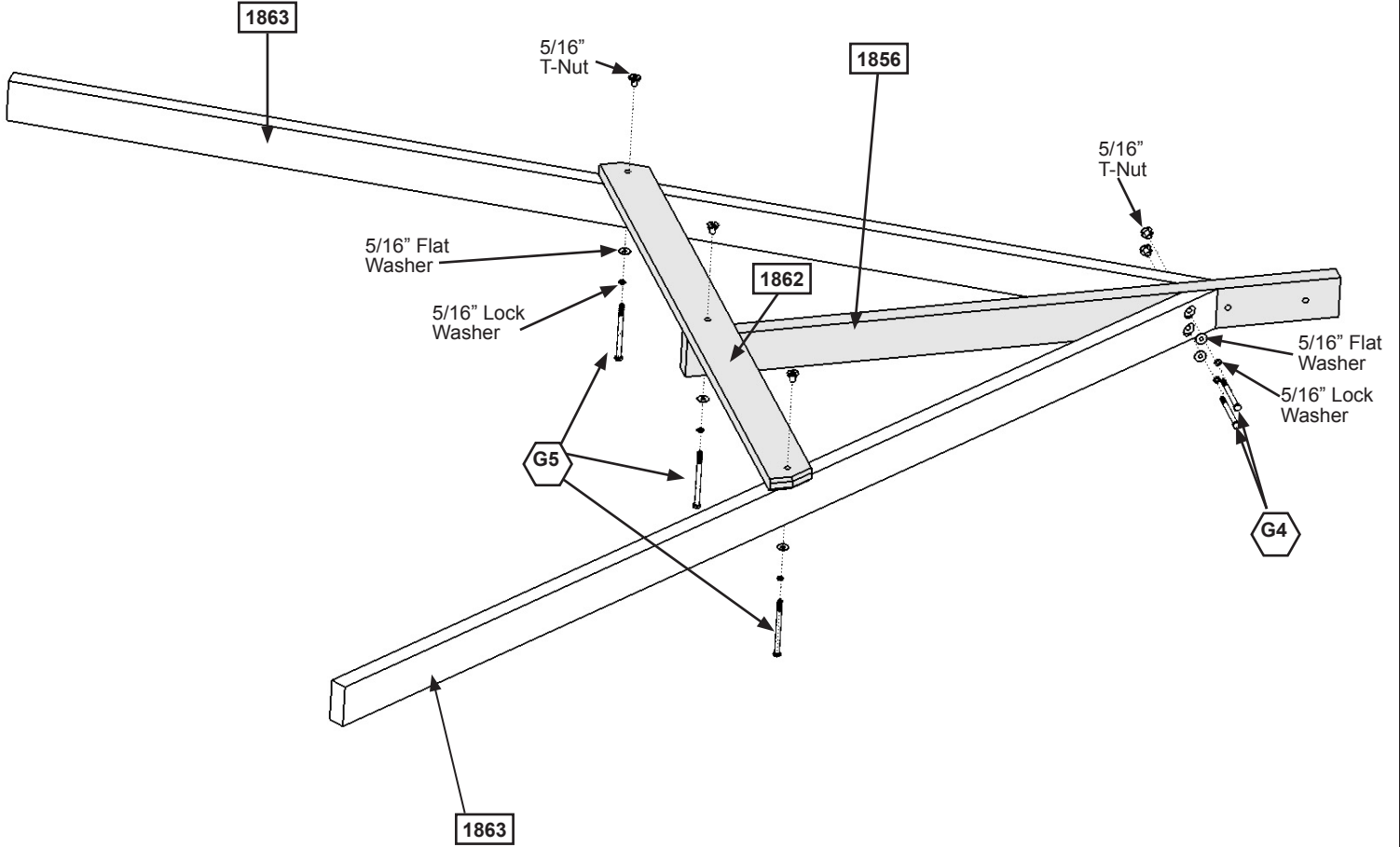

B: Attach (1862) SW Support to both (1863) SW Posts and (1856) SW Upright using 3 (G5) 5/16 x 4-1/2" Hex Bolts (with lock washer, flat washer and t-nut). (fig. 4.1)

Wood Parts

- 2 x 1863 SW Post 2 x 4 x 86-11/16"
- 1 x 1862 SW Support 5/4 x 4 x 46-1/2"
- 1 x 1856 SW Upright 2 x 4 x 48-5/16"

Hardware

- 2 x G4 5/16 x 4" Hex Bolt
(5/16" lock washer, 5/16" flat washer, 5/16" t-nut)
- 3 x G5 5/16 x 4-1/2" Hex Bolt
(5/16" lock washer, 5/16" flat washer, 5/16" t-nut)

Step 5: Attach Swing End to Swing Beam

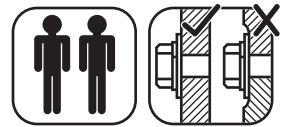

A: Place (4919) SW Rail Block in the centre between (1826) Front Beam and (1825) Back Beam and attach with 1 (H8) 1/4 x 4-1/4" Hex Bolt (with lock washer, flat washer and t-nut). (fig. 5.1 & 5.2)

Fig. 5.1

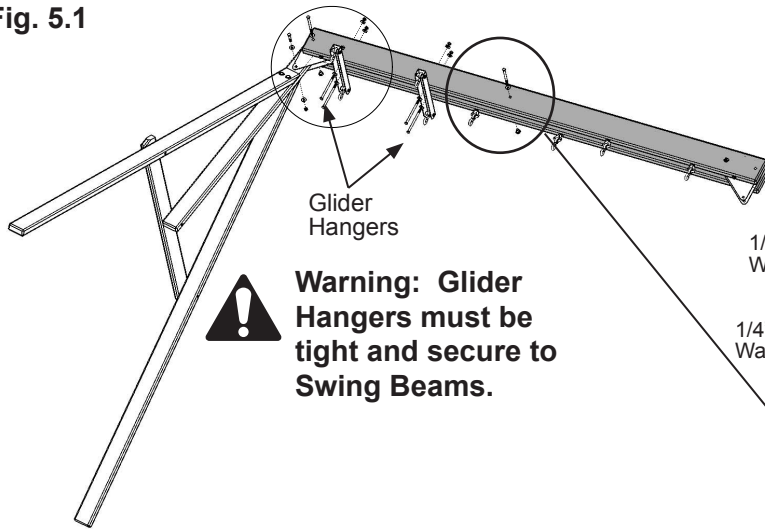
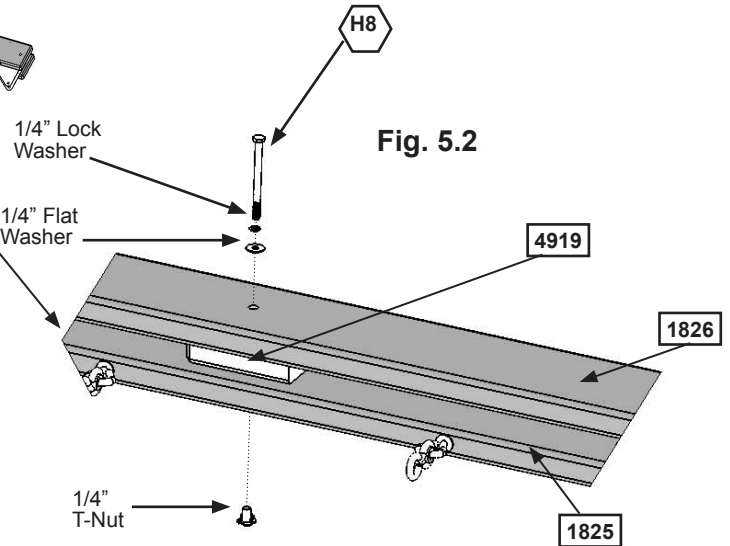

Fig. 5.2



B: Attach Swing Beam Assembly to the side of the Swing End Assembly with the overhang (fig. 5.3 & 5.4) using 1 (G5) 5/16 x 4-1/2" Hex Bolt (with lock washer, flat washer and t-nut) in the top hole of Triangle Plate and 1 (G8) 5/16 x 2" Hex Bolt (with 2 flat washers and lock nut) in the bottom hole of Triangle Plate. (fig. 5.3) Make sure Swing End Assembly flares out at an angle. (fig. 5.4)

C: Attach 2 Glider Hangers to the Swing Beam Assembly using 2 (G7) 5/16 x 5-1/2" Hex Bolt (with 2 flat washers & lock nut) per Glider Hanger. (fig. 5.1 & 5.3)

Fig. 5.4

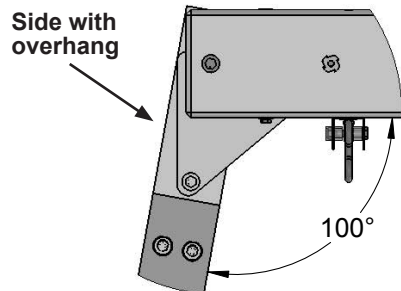
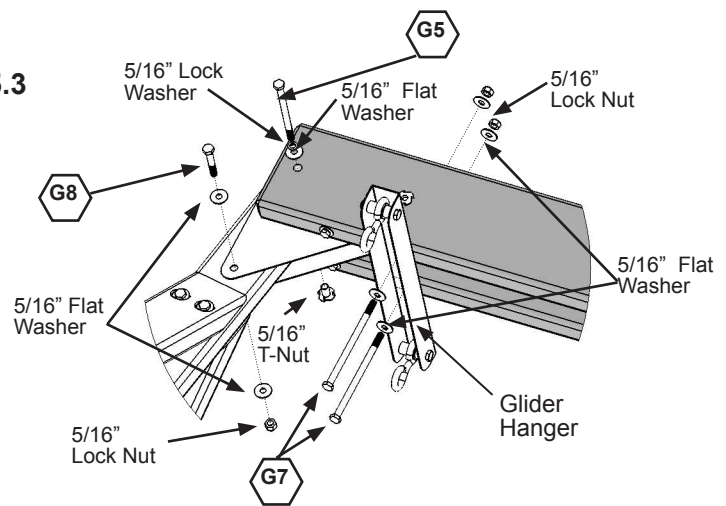

Fig. 5.3



Wood Parts

1 x 4919 SW Rail Block 2 x 4 x 5-3/8"

Hardware

- 1 x H8 1/4 x 4-1/4" Hex Bolt (1/4" lock washer, 1/4" flat washer, 1/4" t-nut)
- 1 x G5 5/16 x 4-1/2" Hex Bolt (5/16" lock washer, 5/16" flat washer, 5/16" t-nut)
- 4 x G7 5/16 x 5-1/2" Hex Bolt (5/16" flat washer x2, 5/16" lock nut)
- 1 x G8 5/16 x 2" Hex Bolt (5/16" flat washer x2, 5/16" lock nut)

Other Parts

2 x Glider Hangers

Step 6: Monkey Rail Assembly

A: Place (9533) MK Rail Long and (9531) MK Rail Short side by side, taking note of the hole orientation. Attach 3 Metal Monkey Bars to the rails using 2 (WL5) 1/4 x 2- 1/2" Wafer Lags (with flat washer) per bar. (fig.6.1).

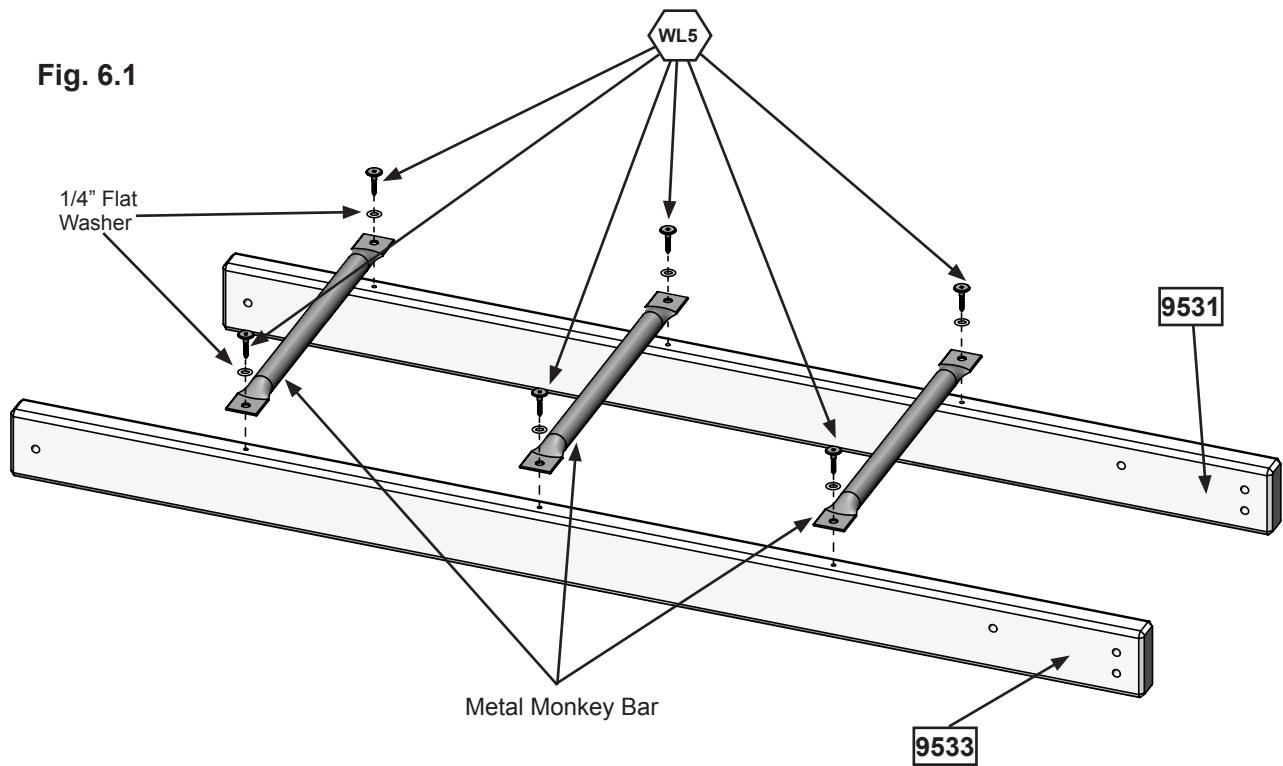

Wood Parts

1 x 9531 MK Rail Short 2 x 4 x 50"

1 x 9533 MK Rail Long 2 x 4 x 54"

Hardware

6 x WL5 1/4 x 2-1/2" Wafer Lag (1/4" flat washer)

Other Parts

3 x Metal Monkey Bar

Step 7: Monkey Ladder Assembly

A: Place 2 (9530) Post MK's side by side taking note of the hole orientation. Install Metal Monkey Bar with 2 (WL5) 1/4 x 2- 1/2" Wafer Lags (with flat washer). (Fig. 7.1)

B: At bottom of (9530) Posts MK attach (9532) MK Ground with 2 (H12) 1/4 x 3" Hex Bolts (with lock washer, flat washer and t-nut). Be sure to keep the bolts loose. (fig. 7.2)

C: Make sure the assembly is square and then attach 1 (0369) Lower Diagonal to each end of (9532) MK Ground with 1 (H2) 1/4 x 2" Hex Bolt (with lock washer, flat washer and t-nut), keeping the bolts loose, and to each (9530) Post MK with 1 (LS2) 1/4 x 2-1/2" Lag Screw (with flat washer). Once lag screws are installed tighten all bolts from Steps B & C.

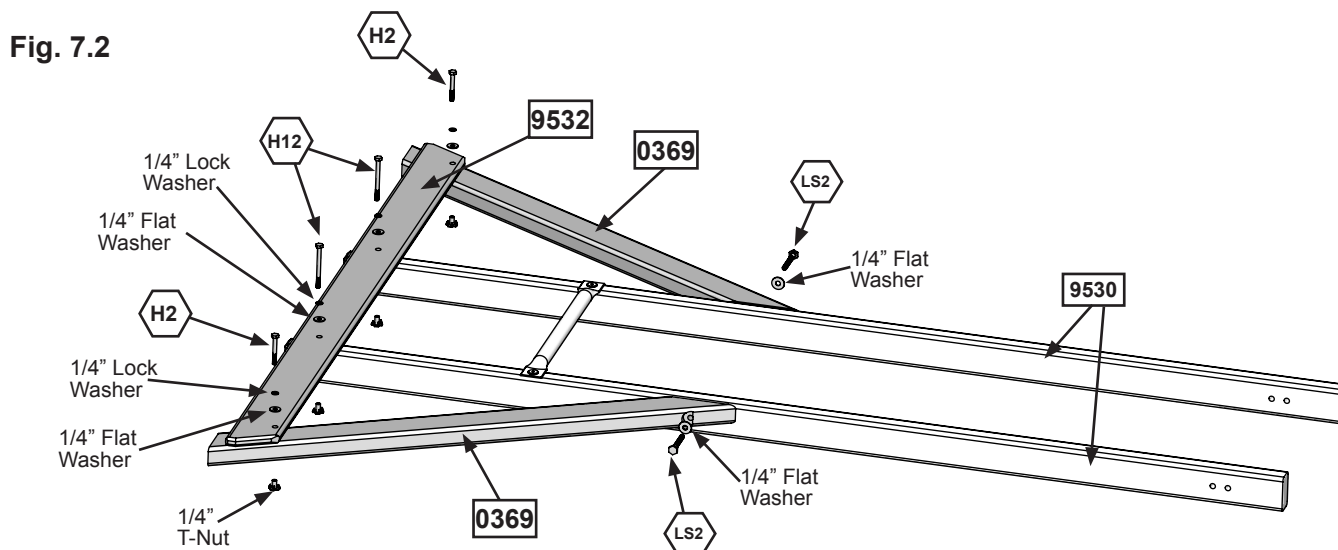
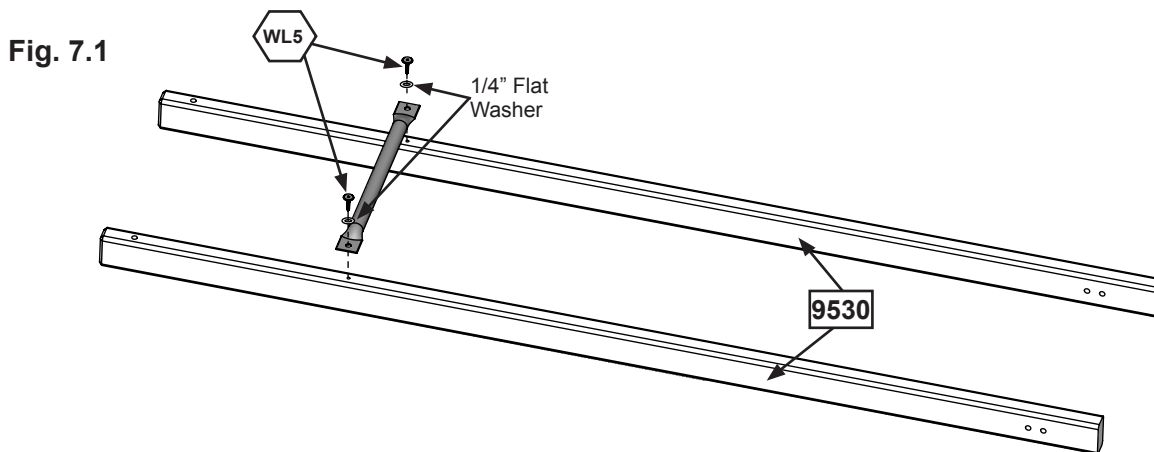

Wood Parts

- 2 x 0369 Lower Diagonal 2 x 3 x 37"
- 1 x 9532 MK Ground 5/8 x 3 3/8 x 52 1/2"
- 2 x 9530 Post MK 1 3/8 x 2 1/2 x 66 5/8"

Hardware

- 2 x H12 1/4 x 3" Hex Bolt (1/4" lock washer, 1/4" flat washer, 1/4" t-nut)
- 2 x H2 1/4 x 2" Hex Bolt (1/4" lock washer, 1/4" flat washer, 1/4" t-nut)
- 2 x LS2 1/4 x 2-1/2" Lag Screw (1/4" flat washer)
- 2 x WL5 1/4 x 2-1/2" Wafer Lag (1/4" flat washer)

Other Parts

- 1 x Metal Monkey Bar

Step 8: Connect Monkey Bar Assemblies



A: Position the end of the Monkey Rail Assembly over the Monkey Ladder Assembly, taking note of the hole orientation and making sure the bars are on the top. Check to make sure that the ends are flush and the assembly is square, then connect the assemblies using 2 Triangle Plates with 5 (G8) 5/16 x 2" Hex Bolts (with 2 flat washers, and lock nut) per side. (fig. 8.1, 8.2 and 8.3)

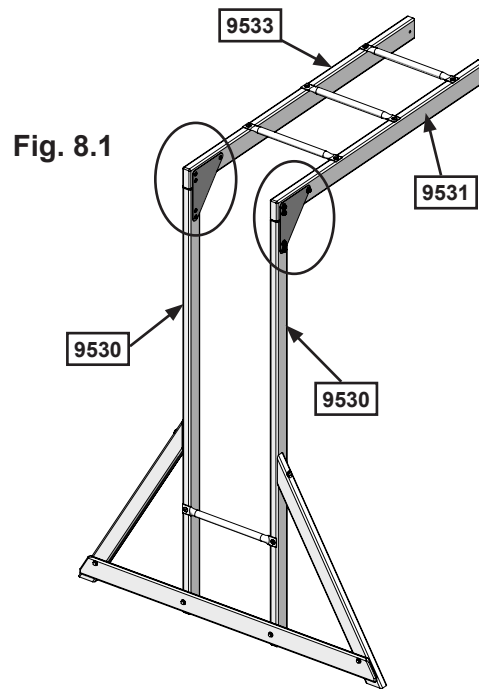

Fig. 8.1

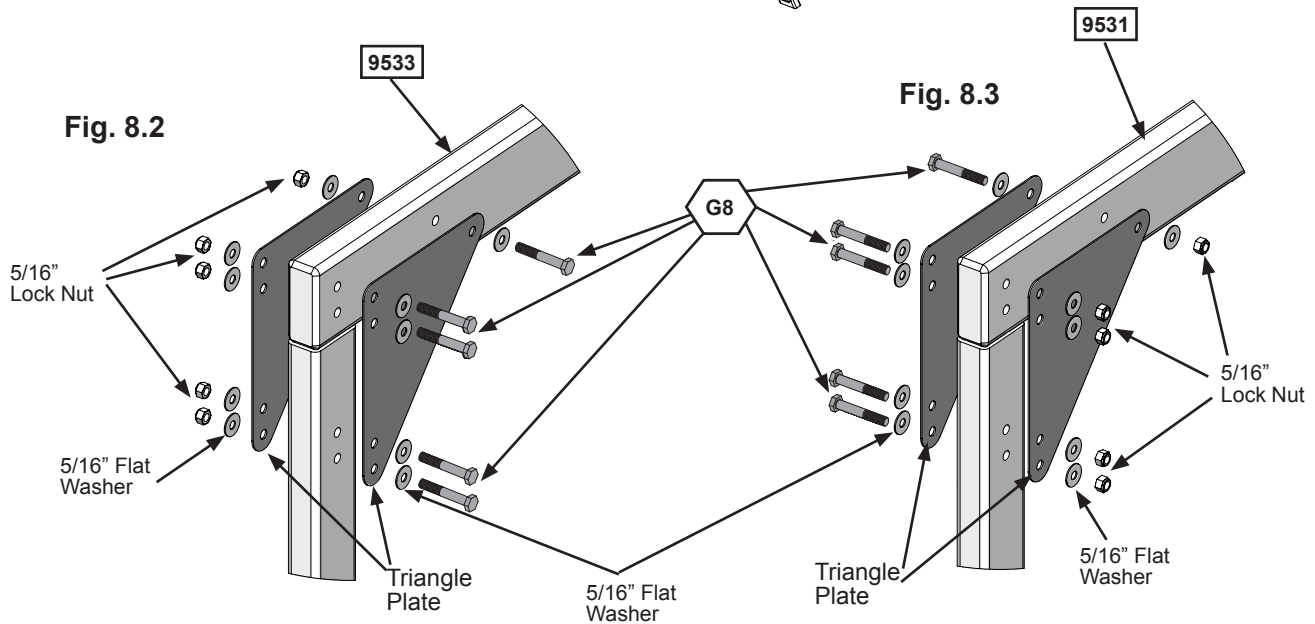



Fig. 8.2

Fig. 8.3

Hardware
10 x  5/16 x 2" Hex Bolt (5/16" flat washer x2, 5/16" lock nut)

Other Parts
4 x Triangle Plate

Step 9: Cafe Wall Assembly Part 1

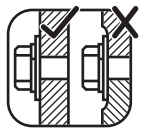

Note: Keep all bolts loose in this step.

A: On the ground lay flat 2 (1931) Posts then attach (2036) Cafe Ground with 4 (H2) 1/4 x 2" Hex Bolts (with lock washer, flat washer and t-nut); (2032) End Floor using 2 (H2) 1/4 x 2" Hex Bolts (with lock washer, flat washer and t-nut) in the bottom holes; and (2030) Side Roof using 2 (H2) 1/4 x 2" Hex Bolts (with lock washer, flat washer and t-nut) as shown in fig. 9.1 and 9.2. *Notice the hole locations in (2032) End Floor.*

Fig. 9.1

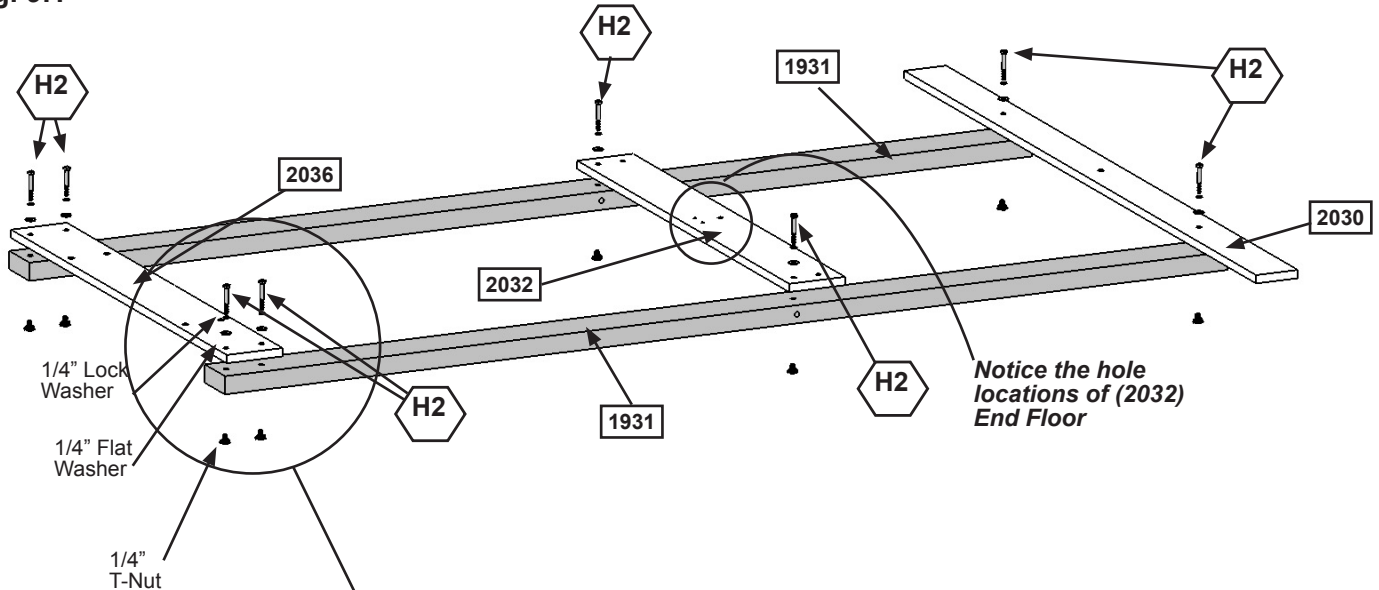
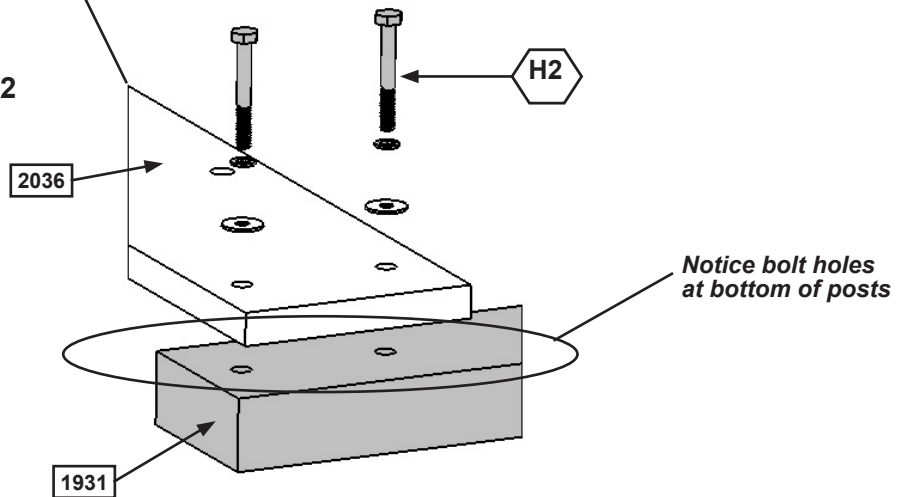

Fig. 9.2



Wood Parts

- 2 x Post 2 x 4 x 81"
- 1 x Side Roof 1 x 4 x 58-1/2"
- 1 x End Floor 1 x 5 x 35-1/4"
- 1 x Cafe Ground 1 x 5 x 35-7/8"

Hardware

- 8 x 1/4 x 2" Hex Bolt (1/4" lock washer, 1/4" flat washer, 1/4" t-nut)

Step 9: Cafe Wall Assembly Part 2



Note: Pre-drill all holes using a 1/8" drill bit before installing the lag screws.

B: Place (2034) Wall Support on both (1931) Posts as shown in fig. 9.3.

C: Place (2031) Roof Support across the bottom of (2032) End Floor, (2034) Wall Support and (2030) Side Roof then loosely attach using 3 (H2) 1/4 x 2" Hex Bolts (with lock washer, flat washer and t-nut) as shown in fig. 9.3 and 9.4. The (2031) Roof Support should sit 2-1/4" from the top of (2032) End Floor. (fig. 9.4)

D: Make sure assembly is square and then fasten (2032) End Floor to (1931) Posts in the top holes using 2 (LS1) 1/4 x 1-1/2" Lag Screws (with flat washer). (fig. 9.3 and 9.5)

E: Make sure (2034) Wall Support is square to the posts then attach to both (1931) Posts using 4 (S2) #8 x 1-1/2" Wood Screws. (fig. 9.3 and 9.5)

F: Make sure the assembly is square then tighten all bolts from this step.

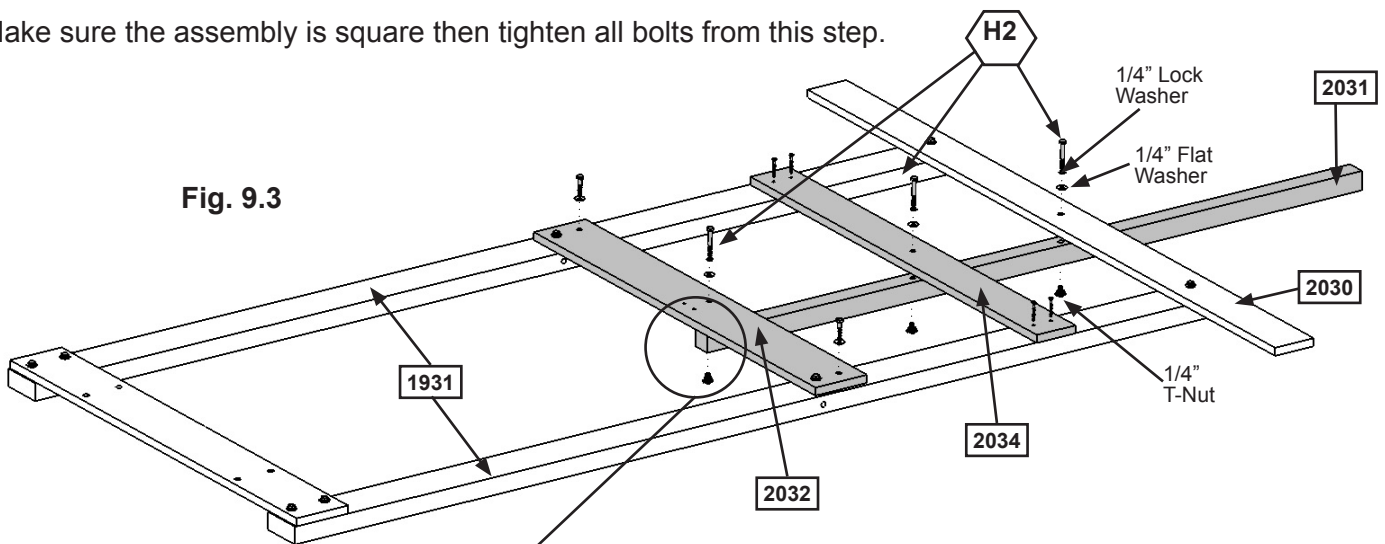

Fig. 9.3

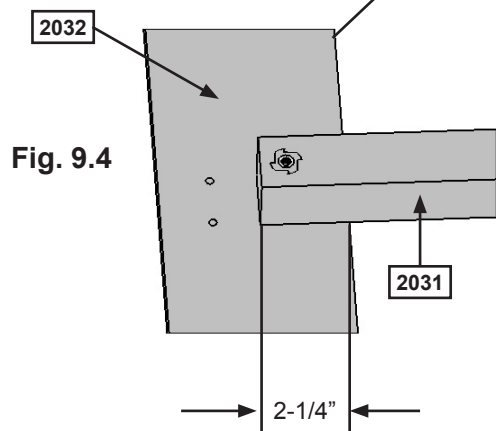

Fig. 9.4

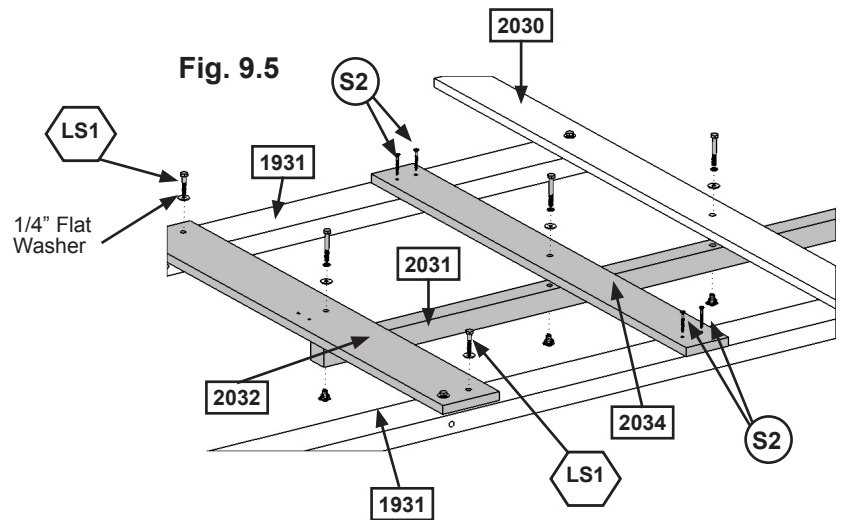

Fig. 9.5

Wood Parts

- 1 x Wall Support 1 x 4 x 35-7/8"
- 1 x Roof Support 2 x 2 x 57-1/8"

Hardware

- 3 x 1/4 x 2" Hex Bolt (1/4" lock washer, 1/4" flat washer, 1/4" t-nut)
- 2 x 1/4 x 1-1/2" Lag Screw (1/4" flat washer)
- 4 x #8 x 1-1/2" Wood Screw

Step 10: Swing Wall Assembly Part 1

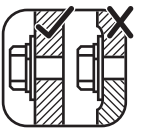

Note: Keep all bolts loose in this step.

A: On the ground lay flat 2 (1931) Posts then attach (2029) Ground SW with 4 (H2) 1/4 x 2" Hex Bolts (with lock washer, flat washer and t-nut); (1895) Floor End using 2 (H2) 1/4 x 2" Hex Bolts (with lock washer, flat washer and t-nut) in the bottom holes; and (2030) Side Roof using 2 (H2) 1/4 x 2" Hex Bolts (with lock washer, flat washer and t-nut) as shown in fig. 10.1.

B: Attach 1 (0369) Lower Diagonal to each side of the (2029) Ground SW with 1 (H2) 1/4 x 2" Hex Bolt (with lock washer, flat washer and t-nut) per diagonal. (fig. 10.1)

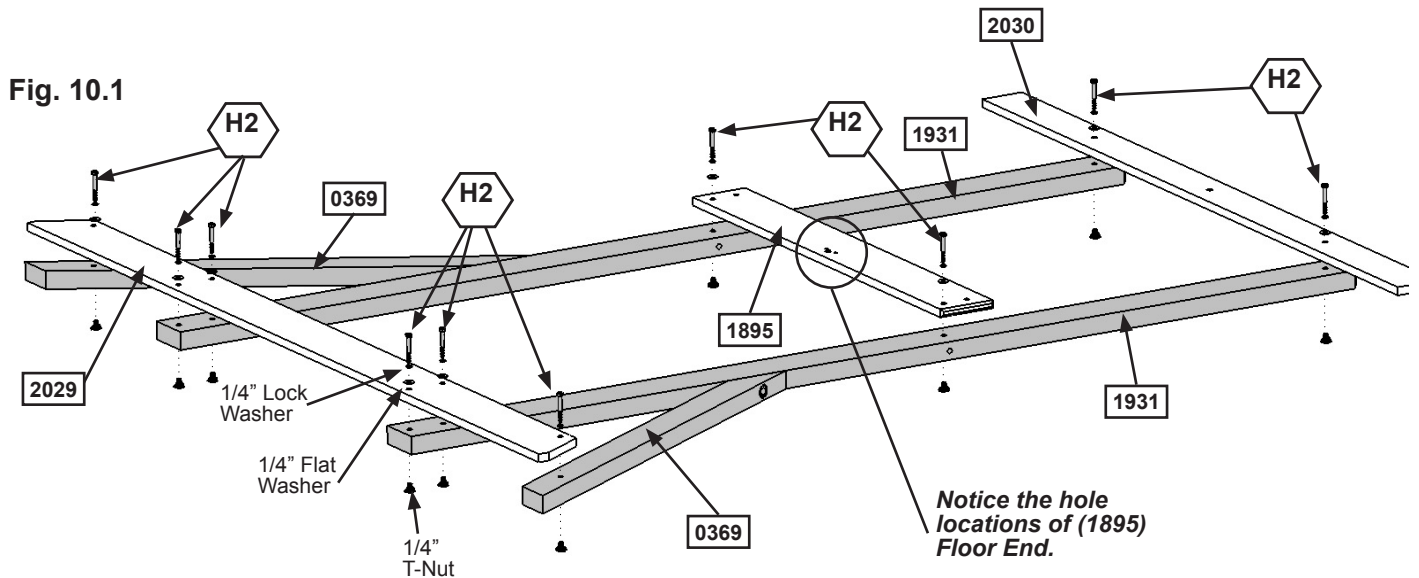

Wood Parts

2 x	1931	Post 2 x 4 x 81"
2 x	0369	Lower Diagonal 2 x 3 x 37"
1 x	2030	Side Roof 1 x 4 x 58-1/2"
1 x	2029	Ground SW 1 x 5 x 72"
1 x	1895	Floor End 1 x 5 x 35-1/4"

Hardware

10 x 1/4 x 2" Hex Bolt (1/4" lock washer, 1/4" flat washer, 1/4" t-nut)

Step 10: Swing Wall Assembly Part 2



Note: Pre-drill all holes using a 1/8" drill bit before installing the lag screws.

C: Place (2034) Wall Support on both (1931) Posts as shown in fig. 10.2.

D: Place (2035) SW Mount across (1895) Floor End, (2034) Wall Support and (2030) Side Roof. Loosely attach using 3 (G4) 5/16 x 4" Hex Bolts (with lock washer, flat washer and t-nut) as shown in fig. 10.2.

E: Make sure assembly is square and then fasten (1895) Floor End to (1931) Posts in the top holes using 2 (LS1) 1/4 x 1-1/2" Lag Screws (with flat washer); and (0369) Lower Diagonals to (1931) Posts with 1 (LS3) 1/4 x 3" Lag Screw (with flat washer) per diagonal. (fig. 10.2 and 10.3)

F: Make sure (2034) Wall Support is square to the posts then attach to both (1931) Posts using 4 (S2) #8 x 1-1/2" Wood Screws. (fig. 10.3)

G: Tighten all bolts, except for the (2035) SW Mount bolts, from this step.

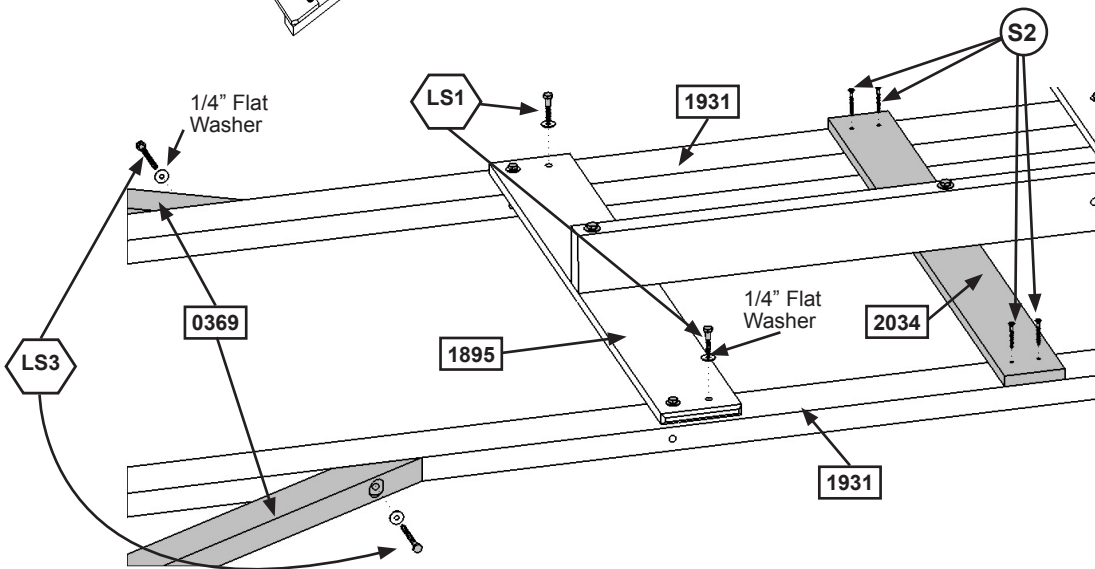
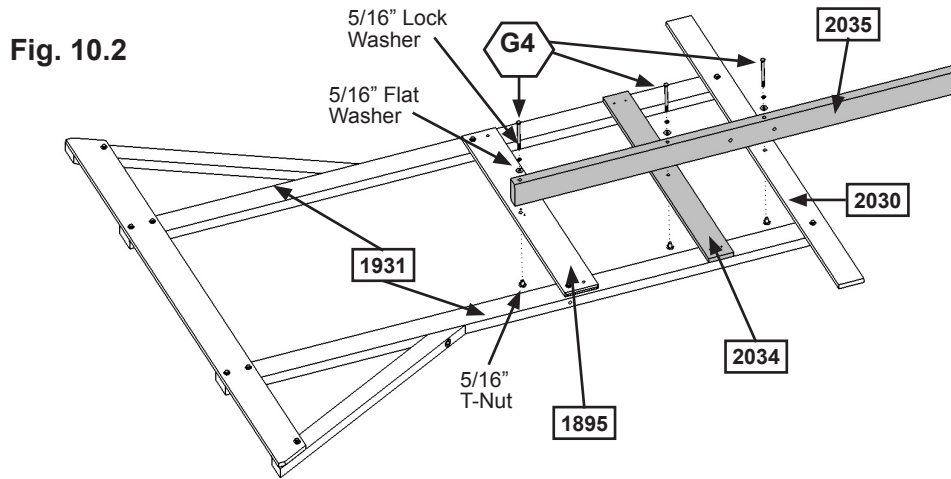

Wood Parts

- 1 x Wall Support 1 x 4 x 35-7/8"
- 1 x SW Mount 2 x 4 x 59-1/2"

Hardware

- 3 x 5/16 x 4" Hex Bolt (5/16" lock washer, 5/16" flat washer, 5/16" t-nut)
- 2 x 1/4 x 1-1/2" Lag Screw (1/4" flat washer)
- 2 x 1/4 x 3" Lag Screw (1/4" flat washer)
- 4 x #8 x 1-1/2" Wood Screw

Step 11: Front Frame Assembly

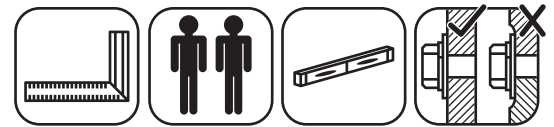

A: On the front side of the assembly, from the inside, attach (1908) Front Floor to each (1931) Post with 2 (H6) 1/4 x 4-3/4" Hex Bolts (with lock washer, flat washer and t-nut). (fig. 11.1 and 11.2)

B: Flush to the bottom of (1908) Front Floor attach (1937) Centre Divider with 1 (H12) 1/4 x 3" Hex Bolt (with lock washer, flat washer and t-nut). (fig. 11.2)

C: Attach (1937) Centre Divider to (2037) Front Top using 1 (H2) 1/4 x 2" Hex Bolt (with lock washer, flat washer and t-nut). (fig. 11.2)

D: Make sure (2037) Front Top is square and level and then attach to both (1931) Posts using 4 (S7) #12 x 2" Pan Screws (with 3/16" flat washers). (fig. 11.2)

Note: Pre-drill all holes using a 1/8" drill bit before installing the lag screws.

E: Attach (1768) Lower Back to the bottom of (1931) Posts with 2 (LS3) 1/4 x 3" Lag Screws (with flat washer) in the top (pre-drilled) holes and 2 (S7) #12 x 2" Pan Screws (with 3/16" flat washers) in the bottom holes as shown in fig. 11.3.

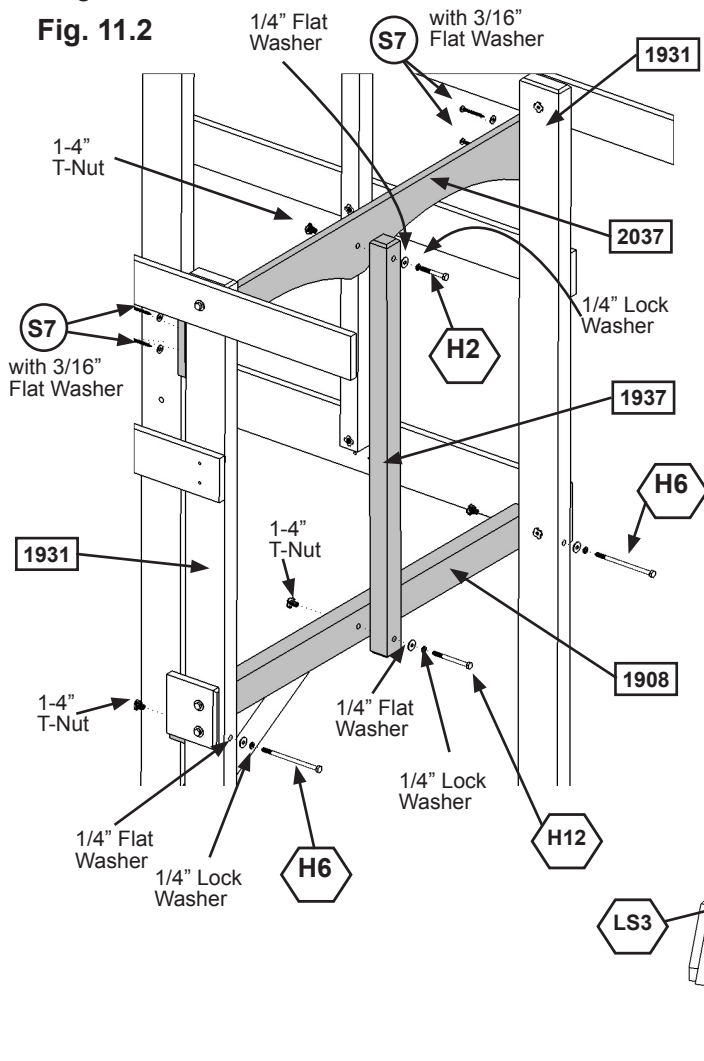

Fig. 11.1

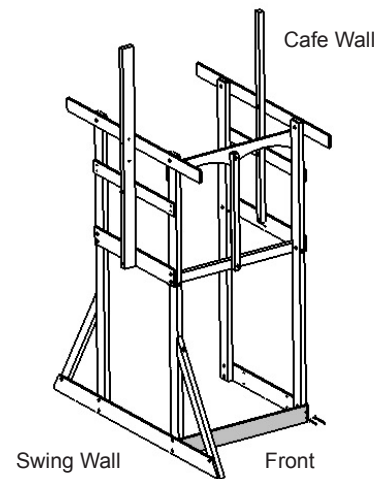
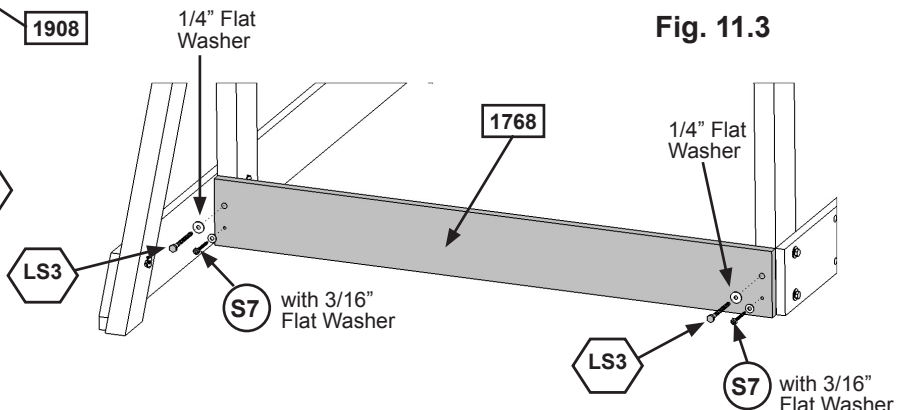

Fig. 11.3



Wood Parts

- 1 x **2037** Front Top 1 x 5 x 38-1/2"
- 1 x **1937** Centre Divider 2 x 2 x 31-3/4"
- 1 x **1908** Front Floor 2 x 3 x 38-1/2"
- 1 x **1768** Lower Back 1 x 5 x 38-1/2"

Hardware

- 1 x **H2** 1/4 x 2" Hex Bolt (1/4" lock washer, 1/4" flat washer, 1/4" t-nut)
- 2 x **H6** 1/4 x 4-3/4" Hex Bolt (1/4" lock washer, 1/4" flat washer, 1/4" t-nut)
- 1 x **H12** 1/4 x 3" Hex Bolt (1/4" lock washer, 1/4" flat washer, 1/4" t-nut)
- 6 x **S7** #12 x 2" Pan Screw (3/16" flat washer)
- 2 x **LS3** 1/4 x 3" Lag Screw (1/4" flat washer)

Step 12: Attach Gusset to Front Frame Assembly



A: Make sure the assembly is square before proceeding.

B: From the inside of the assembly, attach (0312) Gusset flush to the outside edge of (1931) Post on the Swing Wall using 2 (S4) #8 x 3" Wood Screws. The other end of the gusset should be tight against (1908) Front Floor. (fig. 12.1 and 12.2)

C: Attach the other end of (0312) Gusset to (1908) Front Floor with 1 (S3) #8 x 2-1/2" Wood Screw and 1 (S4) #8 x 3" Wood Screw as shown in fig. 12.2.

Fig. 12.2

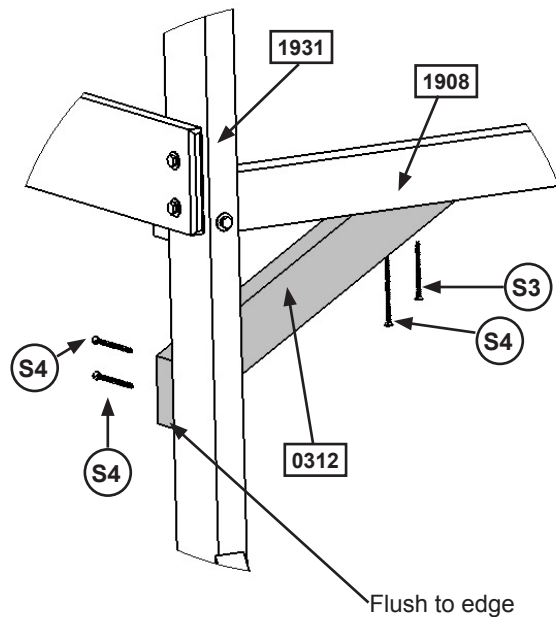
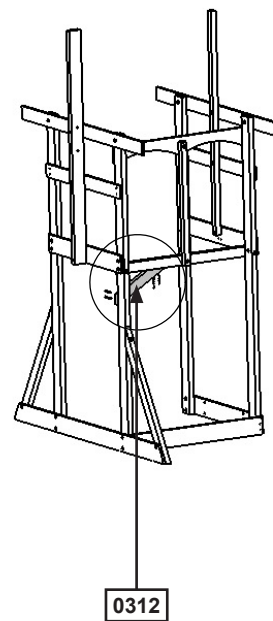

Fig. 12.1



Wood Parts
1 x 0312 Gusset 2 x 3 x 16"

Hardware
1 x (S3) #8 x 2-1/2" Wood Screw
3 x (S4) #8 x 3" Wood Screw

Step 13: Back Wall Assembly Part 1

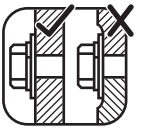

A: Attach (1894) Back Floor to (1761) Side Joist using 2 (H3) 1/4 x 2-1/2" Hex Bolts (with lock washer, flat washer and t-nut) and 2 (S7) #12 x 2" Pan Screws as shown in fig. 13.1.

B: On the back side of the assembly, attach (1894) Back Floor to both (1931) Posts, with (1761) Side Joist on the inside of the assembly, using 2 (H5) 1/4 x 4-1/2" Hex Bolts (with lock washer, flat washer and t-nut). (fig. 13.2 and 13.3)

C: Attach (2033) MK Mount to (1894) Back Floor with 1 (H13) 1/4 x 3-1/2" Hex Bolt (with lock washer, flat washer and t-nut). (fig. 13.2 and 13.3).

Fig. 13.1

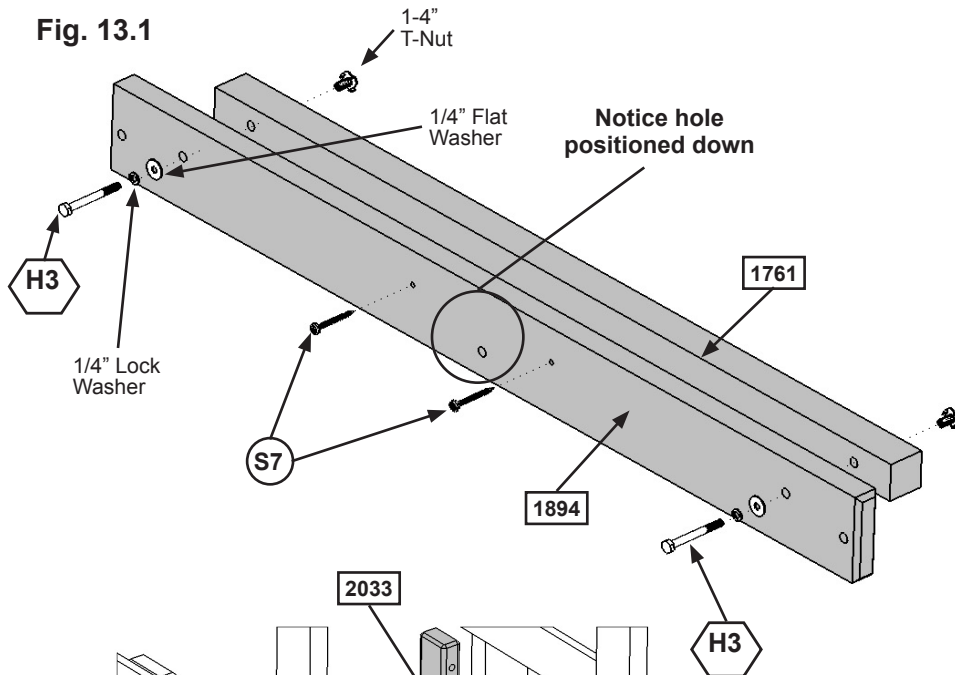

Fig. 13.2

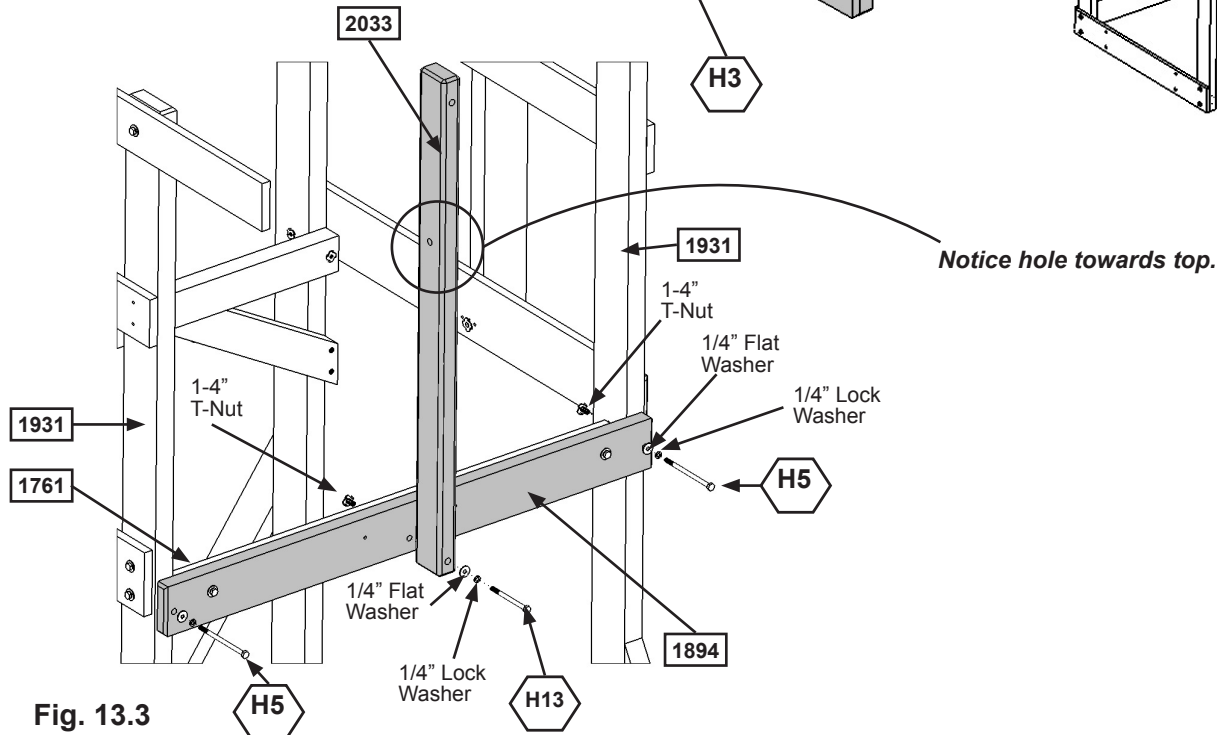
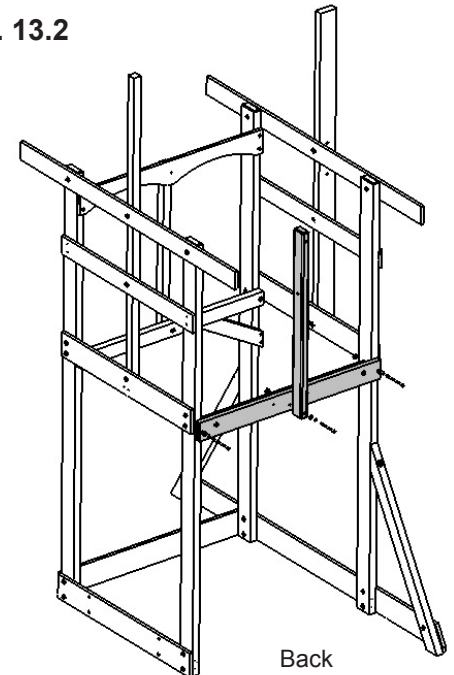

Fig. 13.3

Wood Parts

- 1 x [1761] Side Joist 2 x 3 x 34-3/4"
- 1 x [1894] Back Floor 5/4 x 4 x 38-1/2"
- 1 x [2033] MK Mount 2 x 3 x 35"

Hardware

- 2 x [H3] 1/4 x 2-1/2" Hex Bolt (1/4" lock washer, 1/4" flat washer, 1/4" t-nut)
- 2 x [H5] 1/4 x 4-1/2" Hex Bolt (1/4" lock washer, 1/4" flat washer, 1/4" t-nut)
- 1 x [H13] 1/4 x 3-1/2" Hex Bolt (1/4" lock washer, 1/4" flat washer, 1/4" t-nut)
- 2 x [S7] #12 x 2" Pan Screw

Step 13: Back Wall Assembly Part 2



Note: Pre-drill all holes using a 1/8" drill bit before installing the lag screws.

D: Attach (2033) MK Mount to (1906) Top Front Back using 1 (H12) 1/4 x 2" Hex Bolt (with lock washer, flat washer and t-nut). (fig. 13.4 and 13.6)

E: Make sure (1906) Top Front Back is level and then attach to both (1931) Posts using 4 (S7) #12 x 2" Pan Screws (with 3/16" flat washers). (fig. 13.4)

F: Attach (1768) Lower Back to the bottom of (1931) Posts with 2 (LS3) 1/4 x 3" Lag Screws (with flat washer) in the top (pre-drilled) holes and 2 (S7) #12 x 2" Pan Screws (with 3/16" flat washers) in the bottom holes as shown in fig.13.5 and 13.6.

Fig. 13.4

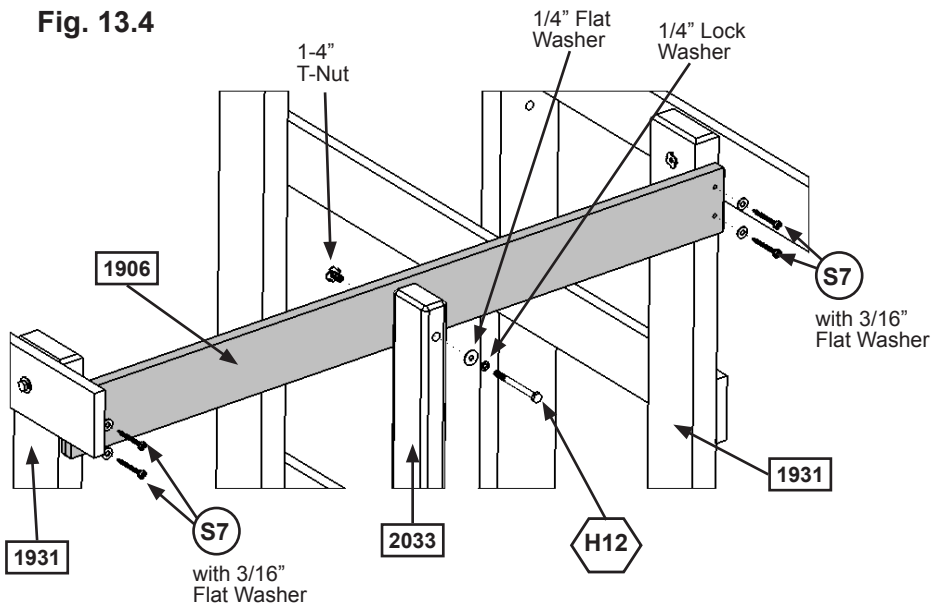

Fig. 13.6

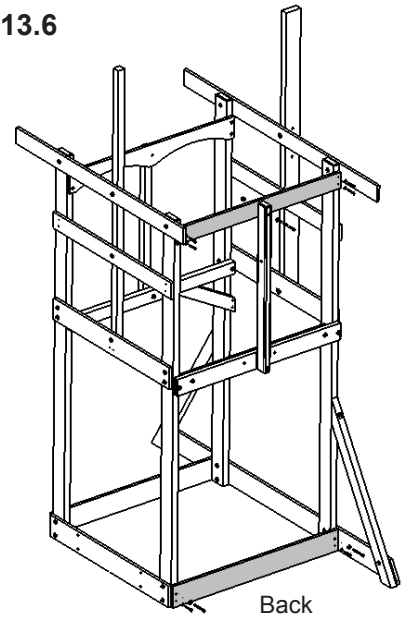
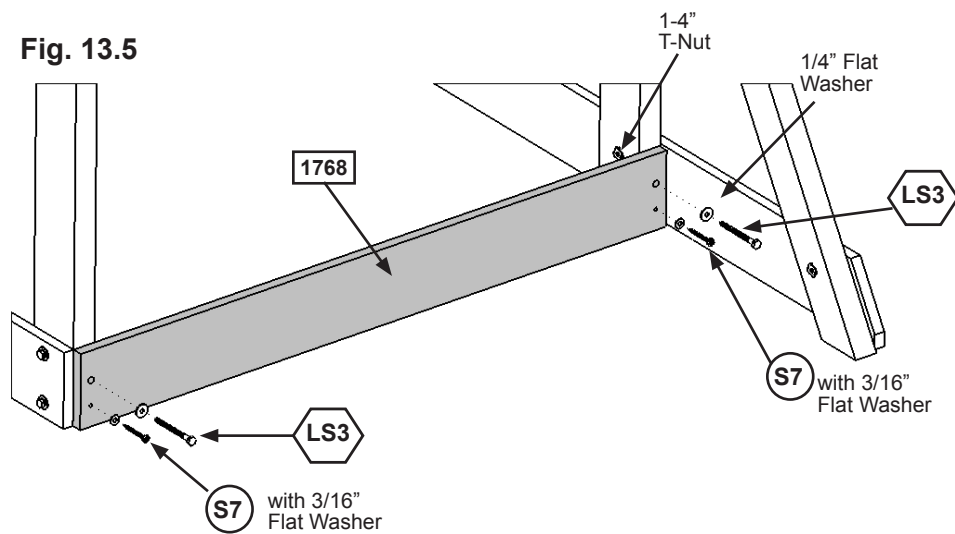

Fig. 13.5



Wood Parts

- 1 x **1906** Top Front Back 1 x 4 x 38-1/2"
- 1 x **1768** Lower Back 1 x 5 x 38-1/2"

Hardware

- 1 x **H12** 1/4 x 3" Hex Bolt (1/4" lock washer, 1/4" flat washer, 1/4" t-nut)
- 2 x **LS3** 1/4 x 3" Lag Screw (1/4" flat washer)
- 6 x **S7** #12 x 2" Pan Screw (with 3/16" flat washer)

Step 14: Attach Ground Stakes

MOVE FORT TO FINAL LOCATION. FINAL LOCATION MUST BE LEVEL GROUND



Warning! To prevent tipping and avoid potential injury, stakes must be driven 10-1/2" into ground. Digging or driving stakes can be dangerous if you do not check first for underground wiring, cables or gas lines.

A: Drive 3 (0318) Ground Stakes 10-1/2" into the ground at 1 (1931) Post and 2 (0369) Lower Diagonals as shown in fig. 14.1. Attach using 2 (S3) #8 x 2-1/2" Wood Screws per ground stake. (fig. 14.2)

Fig. 14.2

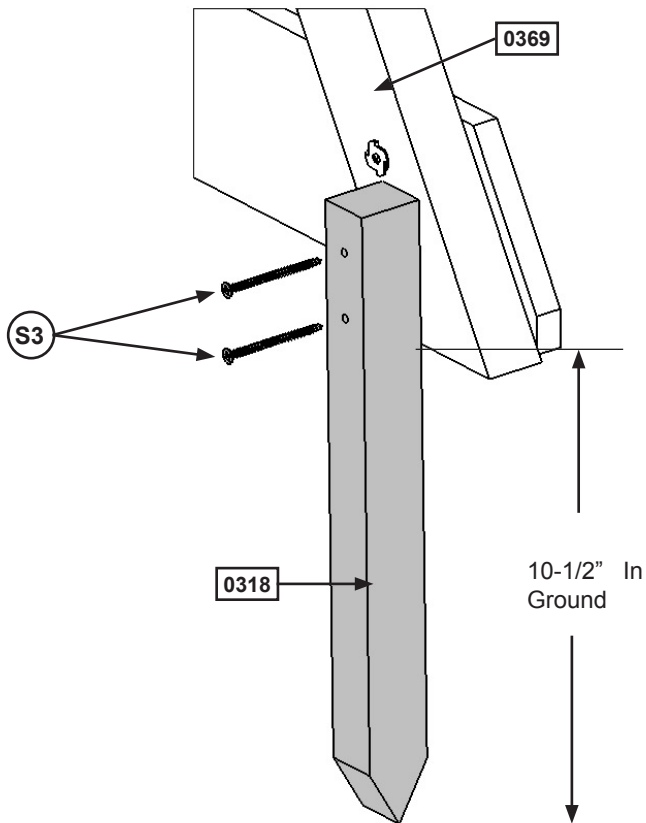
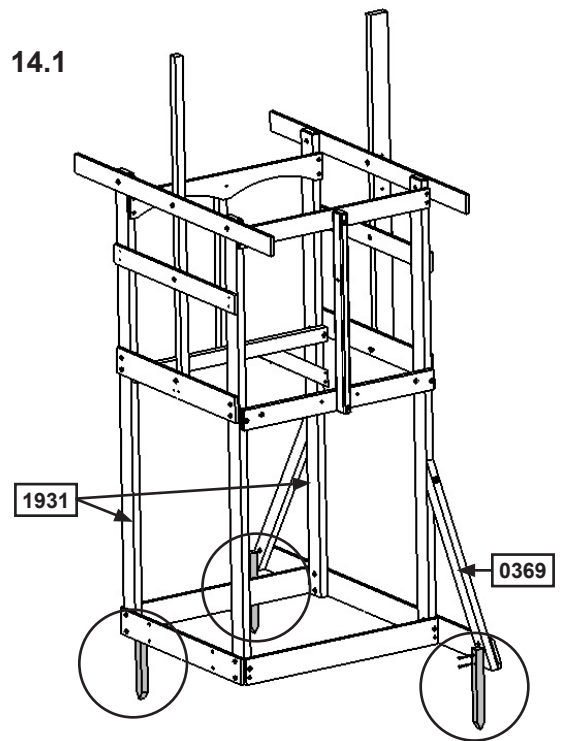

Fig. 14.1



Wood Parts

3 x **0318** Ground Stakes 1-1/4 x 1-1/2 x 14"

Hardware

6 x **S3** #8 x 2-1/2" Wood Screw

Step 15: Attach Rock Wall to Fort

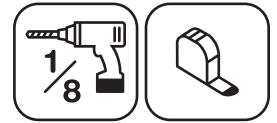

Note: Pre-drill all holes using a 1/8" drill bit before installing the wood screws.

A: Place Rock Wall Assembly from Step 2 centred on and flush to top of (1908) Front Floor (fig. 15.1 and 15.3). Attach (0349) Rock Rails to (1908) Front Floor using 4 (S15) #8 x 1-3/4" Wood Screws as shown in fig. 15.2.

B: Attach (1779) CE Access Board to top of Rock Wall Assembly, flush to top of (0349) Rock Rails using 4 (S2) #8 x 1-1/2" Wood Screws. (fig. 15.4)

Fig. 15.2

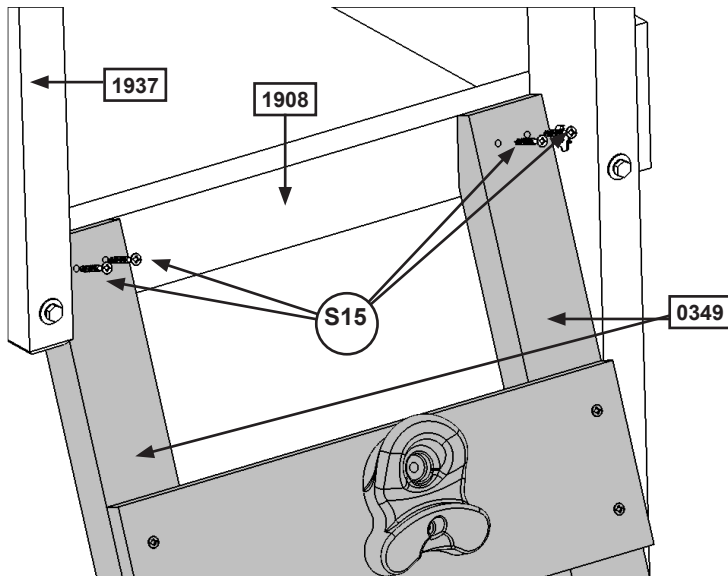

Fig. 15.1

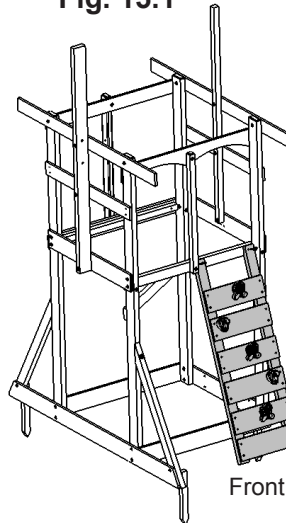

Fig. 15.3

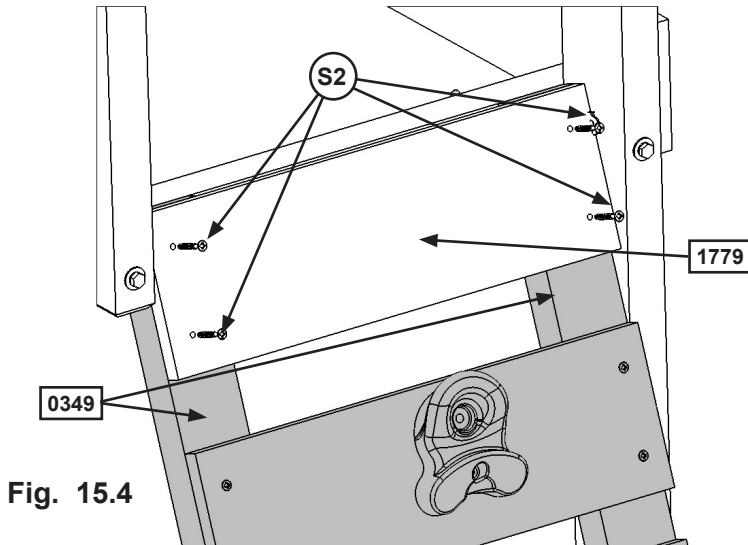
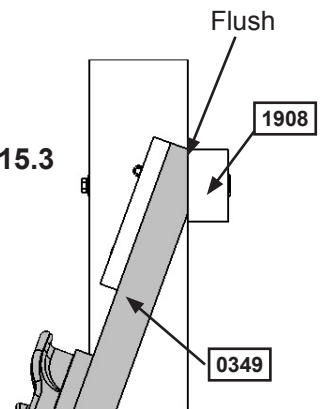

Fig. 15.4

Wood Parts

1 x 1779 CE Access Board 1 x 6 x 17"

Hardware

4 x S15 #8 x 1-3/4" Wood Screw

4 x S2 #8 x 1-1/2" Wood Screw

Step 16: Floor Frame Assembly Part 1



A: Remove the middle and bottom bolts in (2035) SW Mount. Do not discard these bolts, you will re-install them after the (1903) Floor Joist has been attached. (fig. 16.2)

B: From inside of the assembly, measure 2-3/4" down from the top of (1895) Floor End and (2032) End Floor (fig. 16.3 and 16.4), then attach (1903) Floor Joist to each board using the pilot holes with 2 (S4) #8 x 3" Wood Screws per end. Make sure there is a 5/8" gap between (2031) Roof Support and (1903) Floor Joist. (fig. 16.2 and 16.4)

C: Reinstall the middle and bottom bolts in (2035) SW Mount and tighten all three bolts. (fig. 16.1)

Fig. 16.4

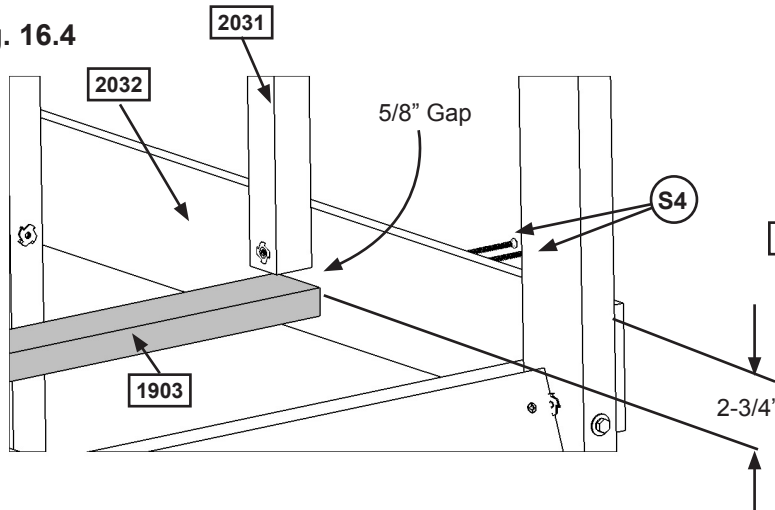

Swing Wall Side

Fig. 16.2

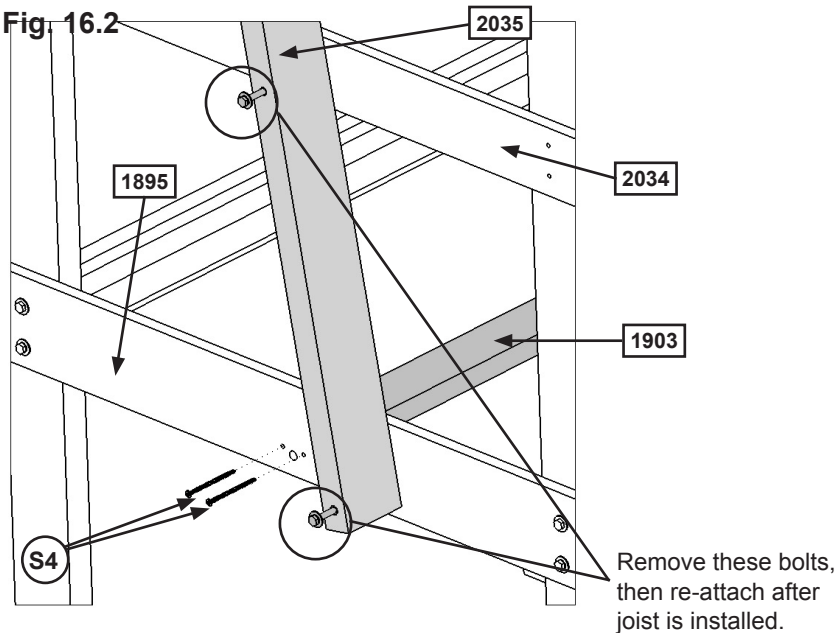

Fig. 16.1

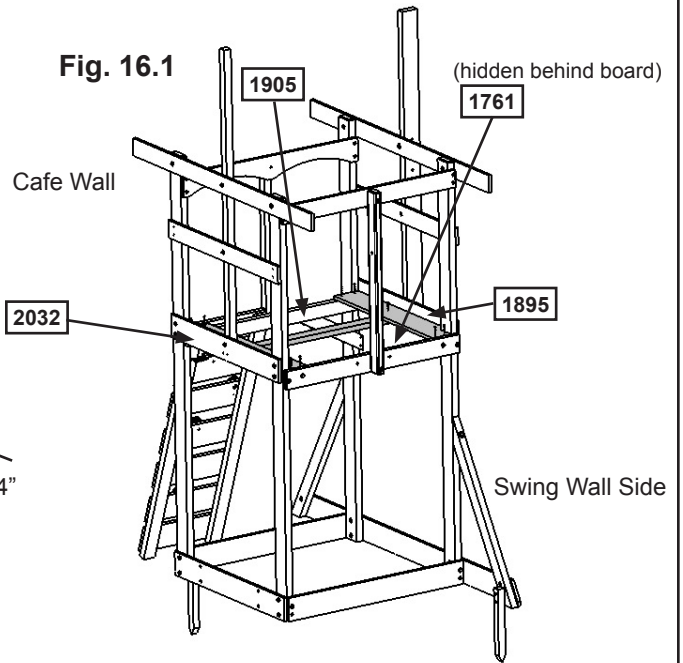
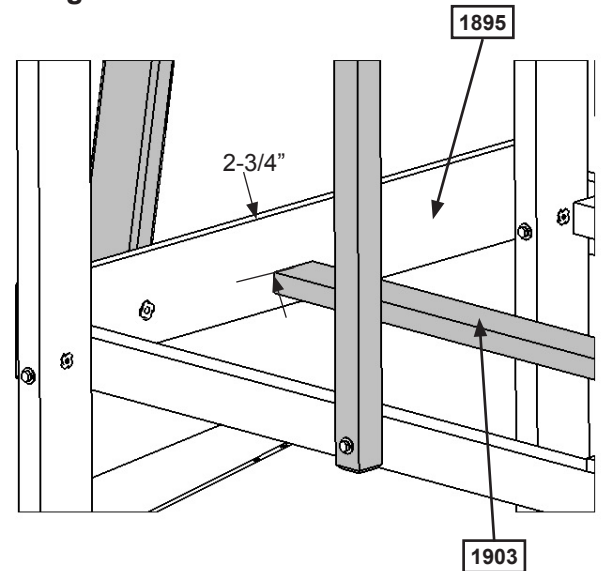

Fig. 16.3



Wood Parts

1 x (1903) Floor Joist 5/4 x 3 x 38-1/2"

Hardware

4 x (S4) #8 x 3" Wood Screw

Step 16: Floor Frame Assembly Part 2

D: Install 1 (1890) CE Gap Board tight to each end of the assembly attaching to (1761) Side Joist, (1903) Floor Joist and (1908) Front Floor using 5 (S2) #8 x 1-1/2" Wood Screws per board. (fig. 16.5)

Fig. 16.5

Swing Wall Side

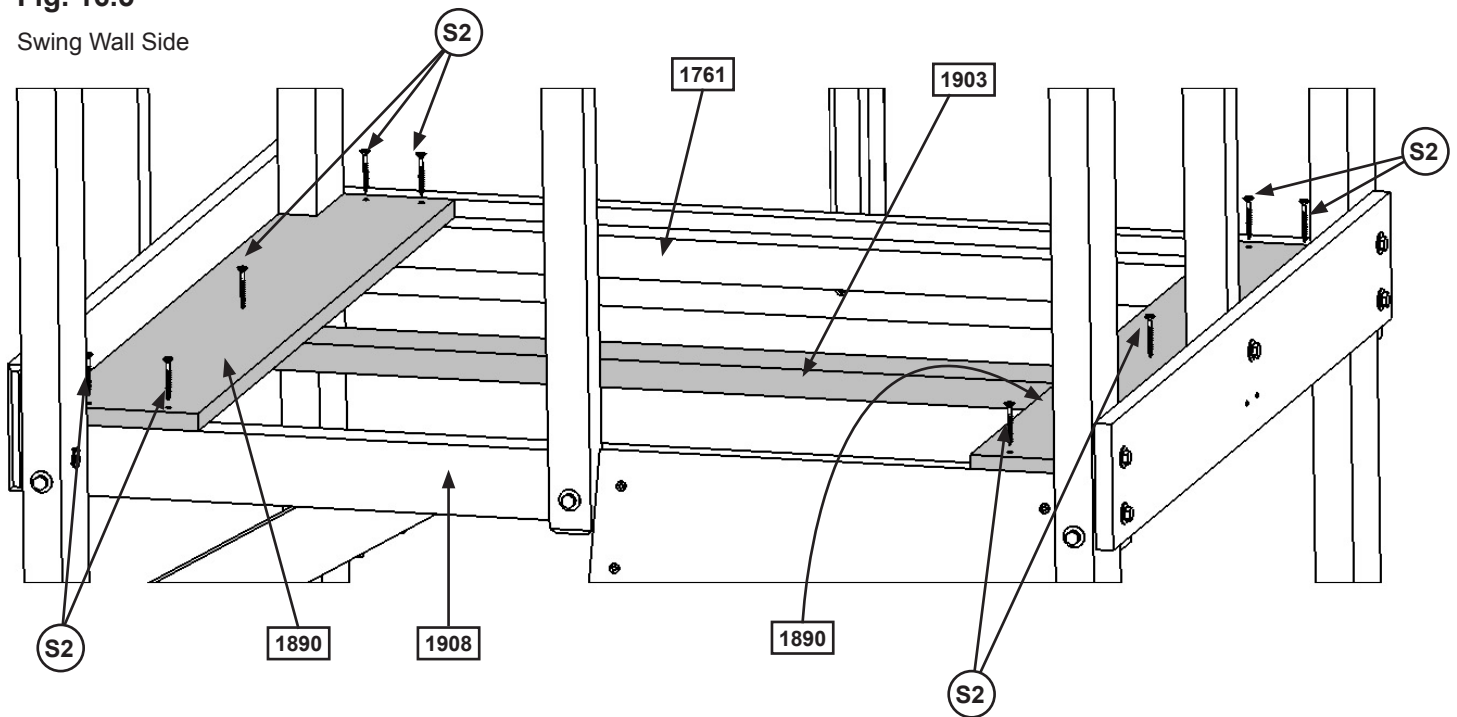

Wood Parts

2 x 1890 CE Gap Board 1 x 6 x 32-1/2"

Hardware

10 x S2 #8 x 1-1/2" Wood Screw

Step 17: Attach Floor Boards

A: In between both (1890) CE Gap Boards place 5 (1889) Floor Boards making sure all boards are evenly spaced. Attach to (1761) Side Joist, (1903) Floor Joist and (1908) Front Floor using 5 (S2) #8 x 1-1/2" Wood Screws per board. (fig. 17.1)

Fig. 17.1

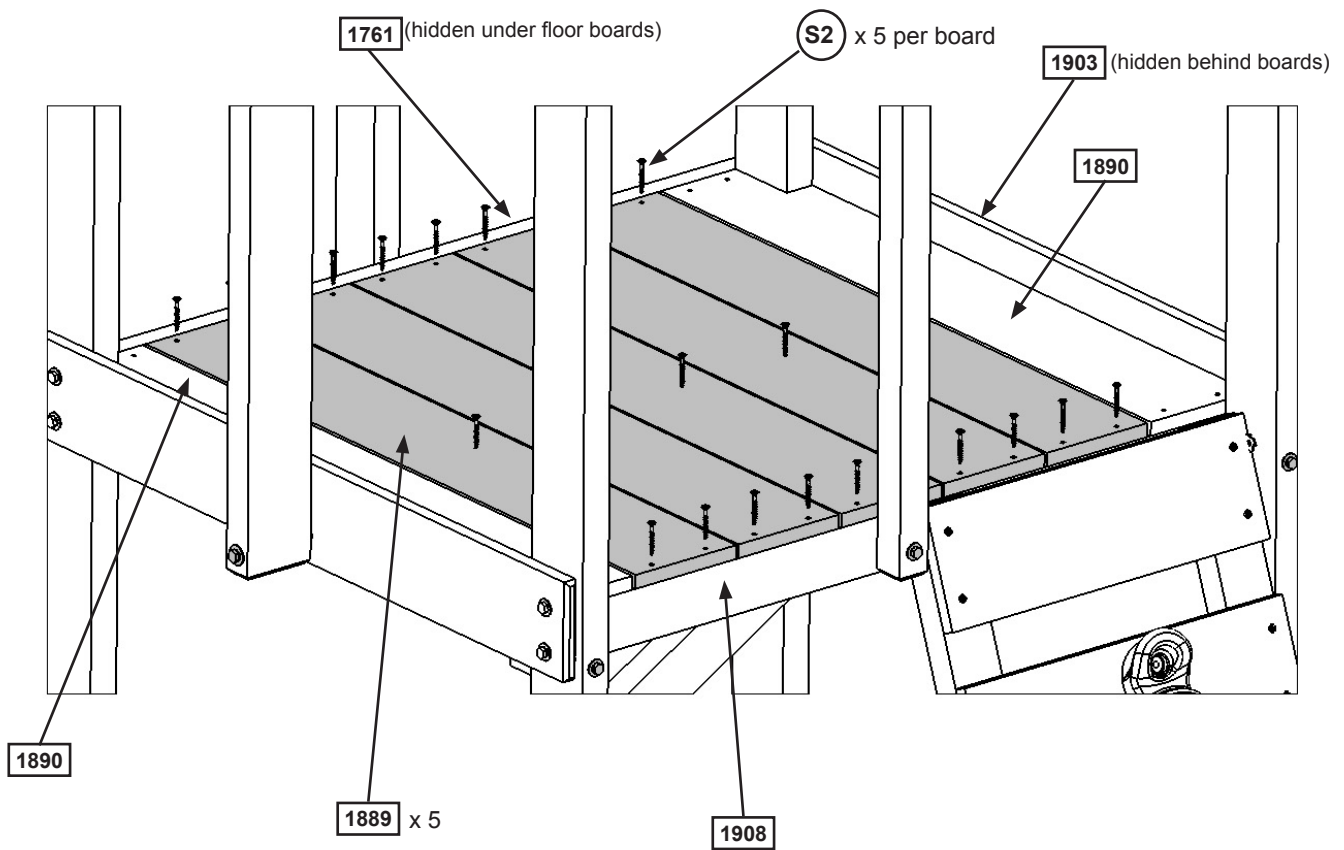

Wood Parts

5 x 1889 Floor Board 1 x 6 x 32-1/2"

Hardware

25 x (S2) #8 x 1-1/2" Wood Screw

Step 18: Chalk Wall Frame Assembly

A: On the back of the assembly, tight to the bottom of (1906) Top Front Back, attach (1944) Panel Frame to (1931) Post using 2 (S2) #8 x 1-1/2" Wood Screws. (fig. 18.1 and 18.2)

B: Place (1227) CE Wall Board tight to the top of (1894) Back Floor and flush to the edge of (1931) Post and (2033) MK Mount. Attach to post using 2 (S2) #8 x 1-1/2" Wood Screws. (fig. 18.2)

Fig. 18.2

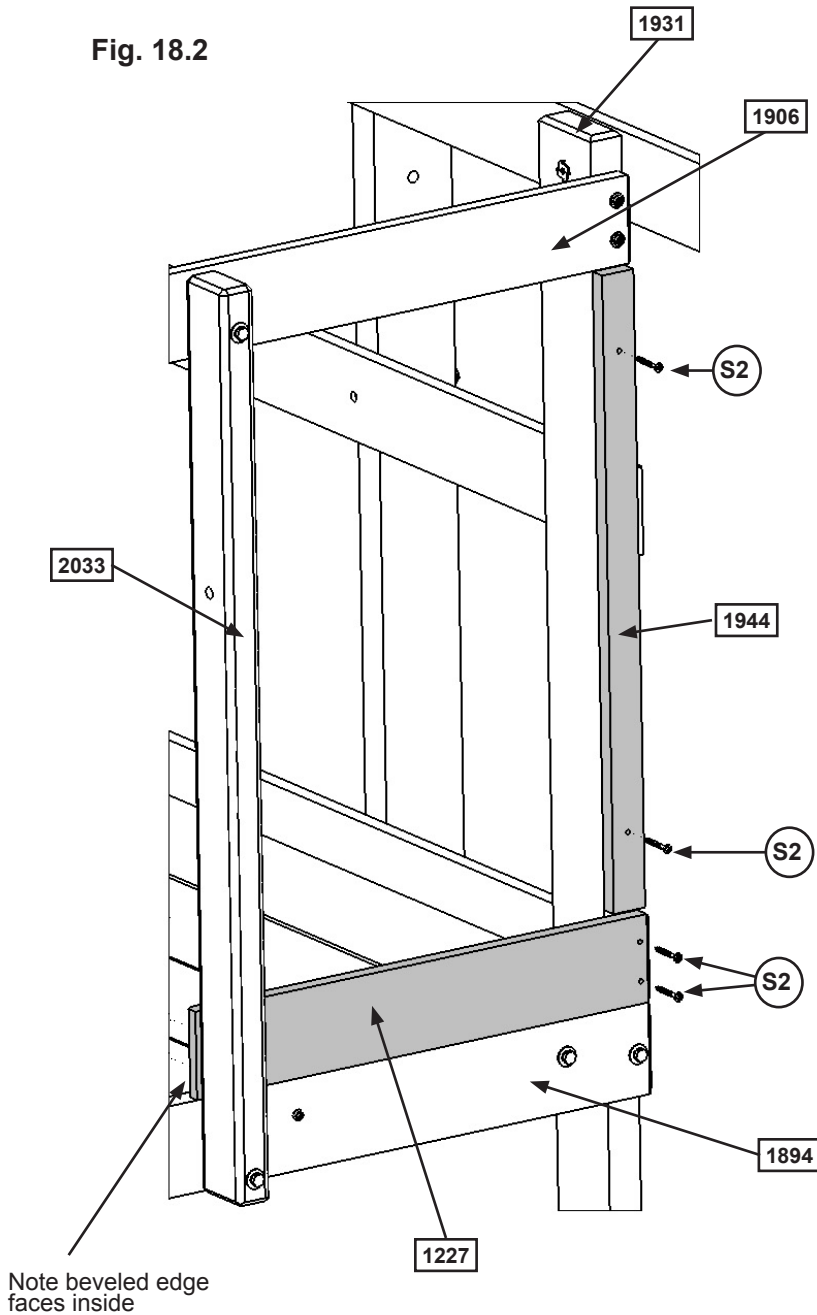
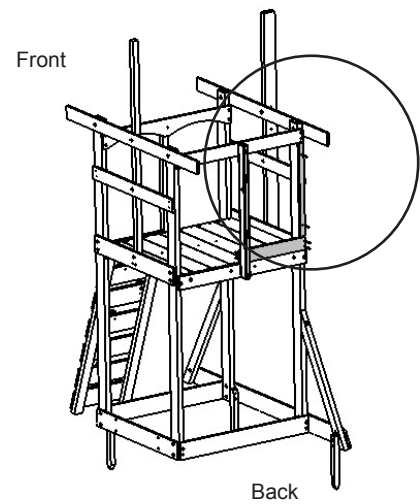

Fig. 18.1



Wood Parts

- 1 x 1944 Panel Frame 1 x 2 x 24-3/8"
- 1 x 1227 CE Wall Board 1 x 4 x 20"

Hardware

- 4 x (S2) #8 x 1-1/2" Wood Screw

Step 19: Attach Chalk Wall/Tarp to Fort

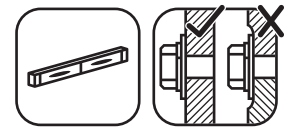

A: Loosen the top bolt in (2033) MK Mount and place the Chalk Wall Tarp in between (2033) MK Mount and (1906) Top Front Back. (fig. 19.1 and 19.2)

B: Attach Chalk Wall Tarp to (1906) Top Front Back, (1944) Panel Frame, (1227) CE Wall Board and (2033) MK Mount using 12 (S5) #8 x 1/2" Pan Screws (with #8 flat washer) as shown in fig. 19.2 and 19.3. The 4 screws on (2033) MK Mount are attached from the inside of the assembly. (fig. 19.3)

Fig. 19.1

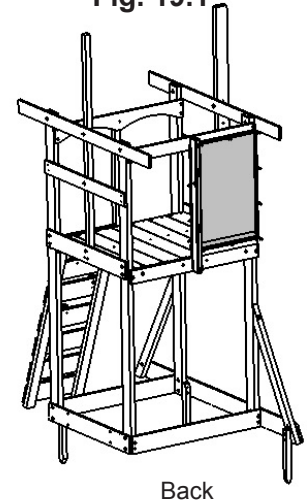

Fig. 19.2

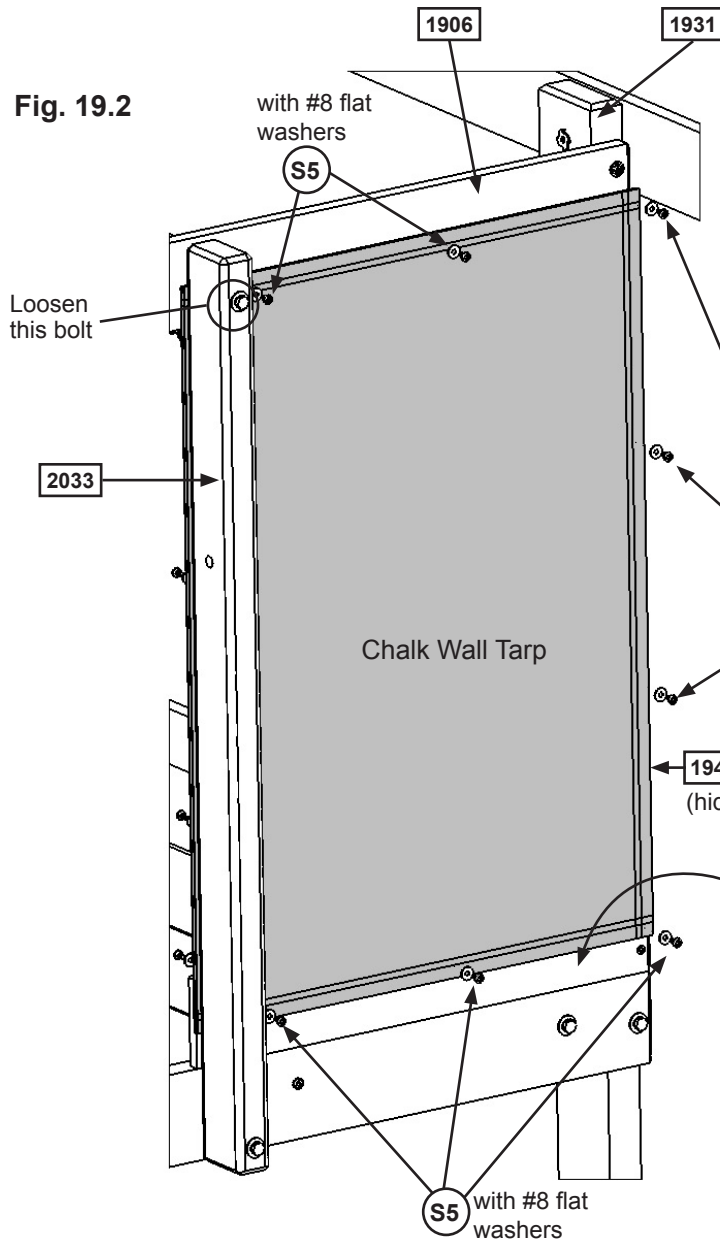
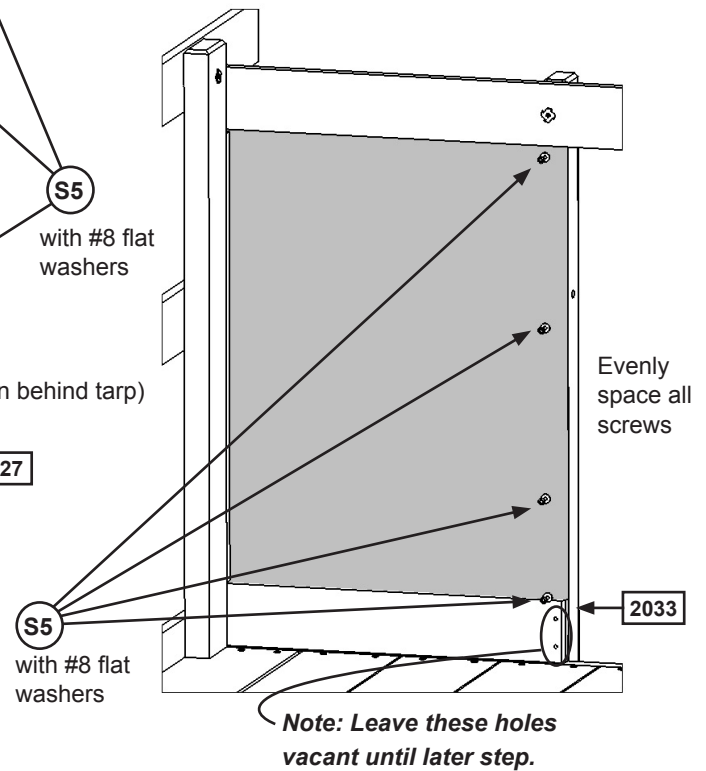

Fig. 19.3
Inside Fort View



Hardware

12 x (S5) #8 x 1/2" Pan Screw (#8 flat washer)

Other Parts

1 x Chalk Wall Tarp

Step 20: Cafe Side Wall Assembly



A: In between both (1931) Posts on Cafe Wall side evenly space and attach 3 (1503) Cedar Walls on each side of (2031) Roof Support to (2034) Wall Support and (2032) End Floor using 4 (S0) #8 x 7/8" Truss Screws per board. The gap between boards should be evenly spaced at 1", not exceeding 1-1/4". Make sure the bottom of the boards are tight against the floor boards and bevelled edges are facing out and are at the top of the boards. (fig. 20.1 and 20.2)

Fig. 20.1

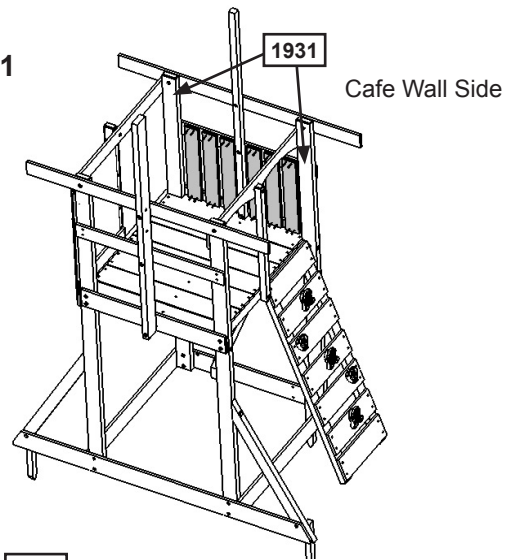
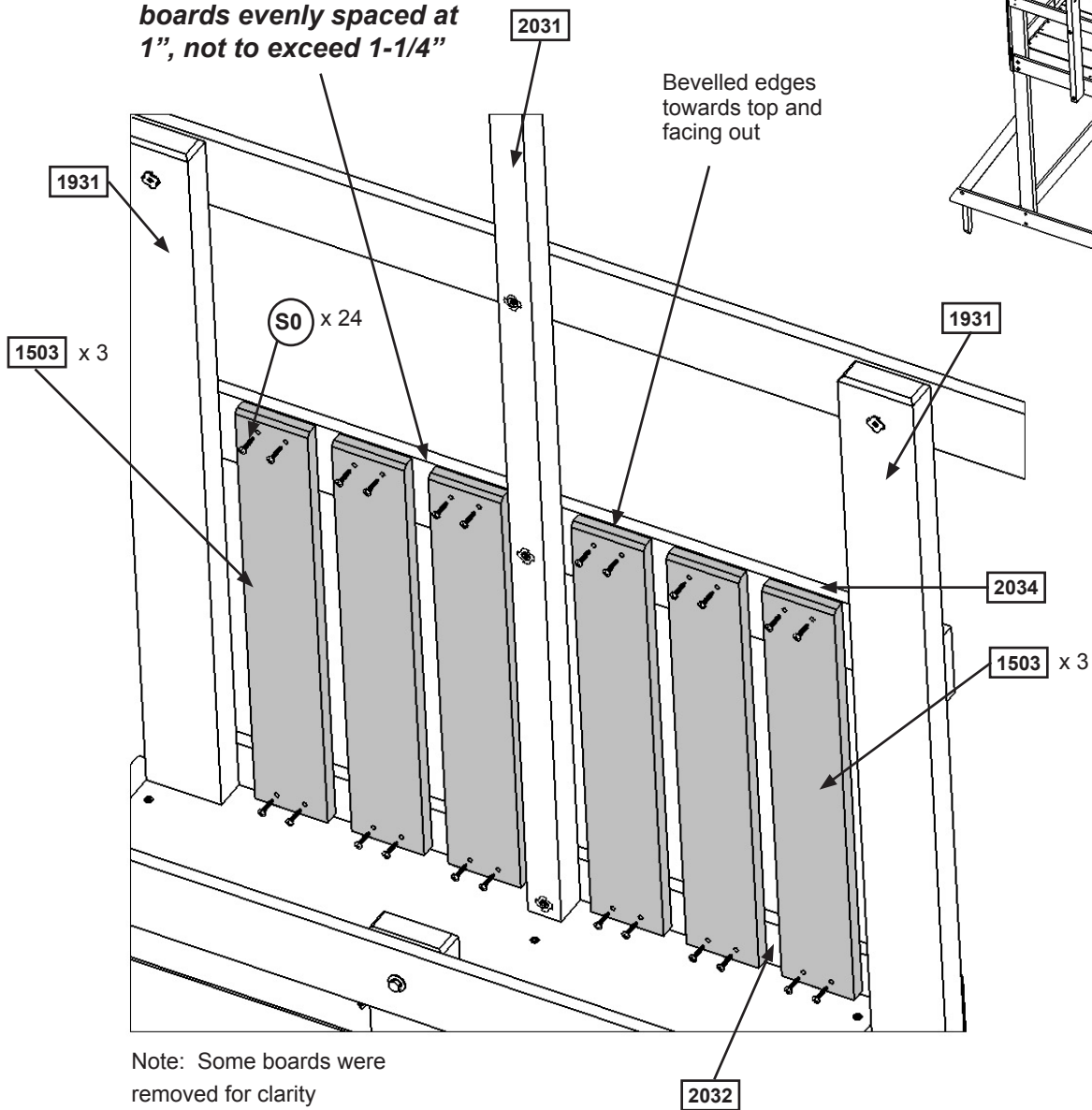

Fig. 20.2

Note: Gaps between boards evenly spaced at 1", not to exceed 1-1/4"



Wood Parts

6 x 1503 Wall Board 1/2 x 4 x 20"

Hardware

24 x S0 #8 x 7/8" Truss Screw

Step 21: Swing Side Wall Assembly



A: In between both (1931) Posts on Swing Wall side attach 6 (1503) Cedar Walls to (2034) Wall Support and (1895) Floor End using 4 (S0) #8 x 7/8" Truss Screws per board. The gap between boards should be evenly spaced at 1", not exceeding 1-1/4". Make sure the bottom of the boards are tight against the floor boards and bevelled edges are facing out and are at the top of the boards. (fig. 21.1 and 21.2)

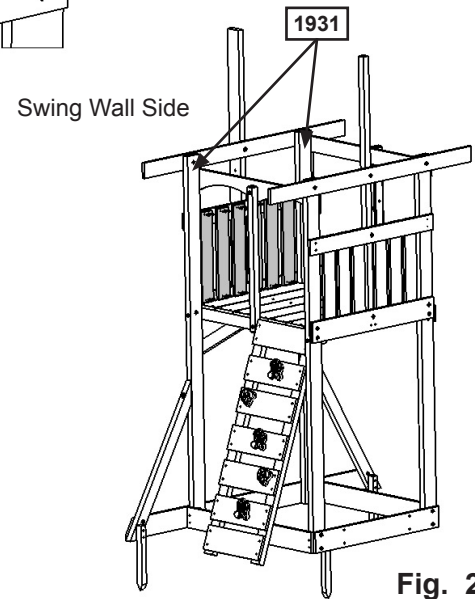
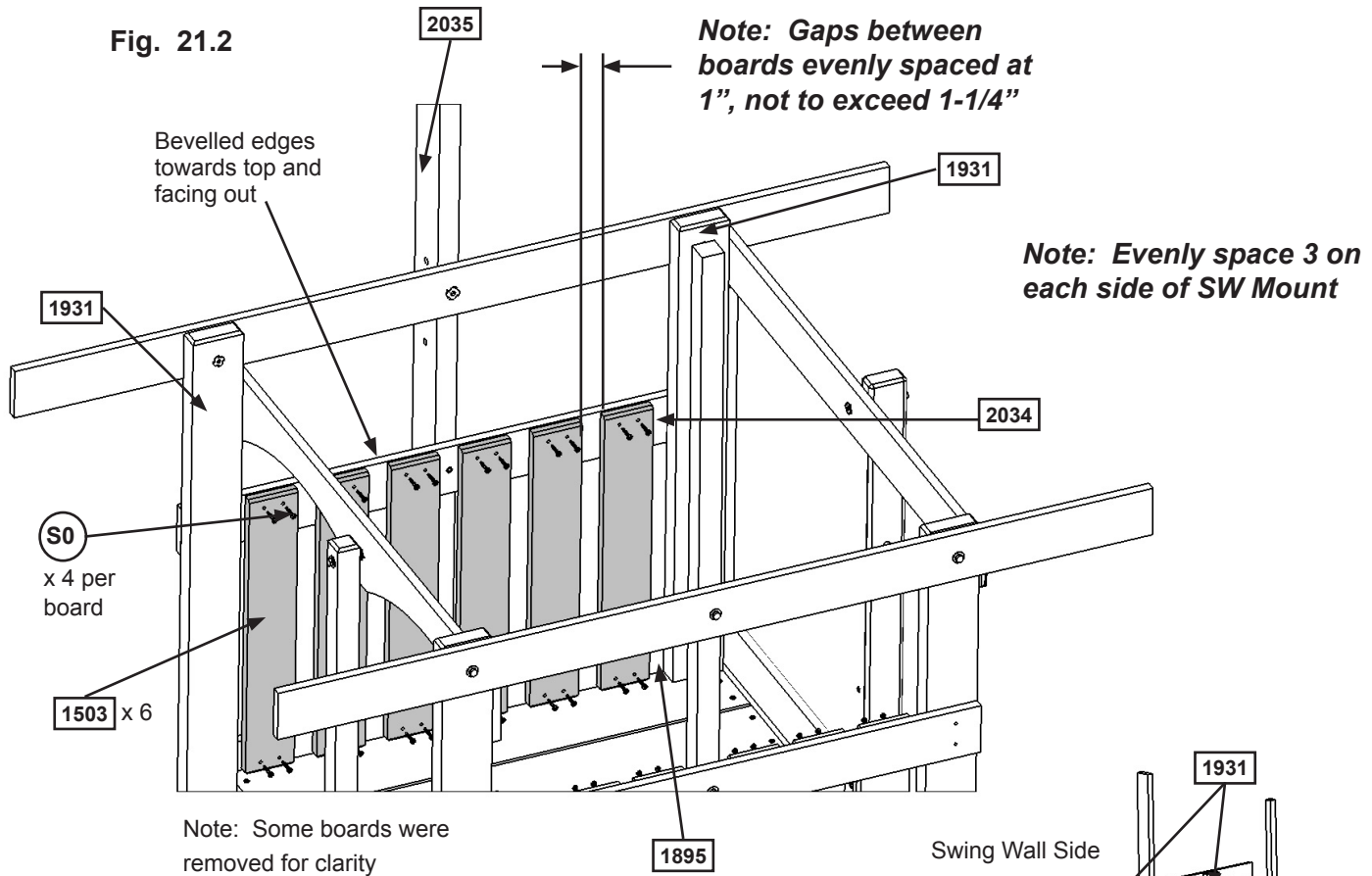

Fig. 21.1

Wood Parts

6 x 1503 Wall Board 1/2 x 4 x 20"

Hardware

24 x S0 #8 x 7/8" Truss Screw

Step 22: Roof Frame Assembly



A: Pre-drill pilot holes for the screws using a 1/8" drill bit and then attach one (1909) Tarp Front Back to each end of each (2030) Side Roof, making sure the pilot holes are centred on the end of (2030) Side Roof, with 4 (S2) #8 x 1-1/2" Wood Screws per (1909) Tarp Front Back. The tops of the Tarp Front Backs should be flush to the top of the Roof Sides. (fig. 22.1)

B: At all 4 corners attach 1 Corner Brace using 3 (S5) #8 x 1/2" Pan Screw per brace as shown in fig. 22.2 and 22.3.

C: Attach (1900) Ridge flush to the end of (2035) SW Mount with 2 (S4) #8 x 3" Wood Screws and to (2031) Roof Support with 1 (S4) #8 x 3" Wood Screw as shown in fig. 22.3.

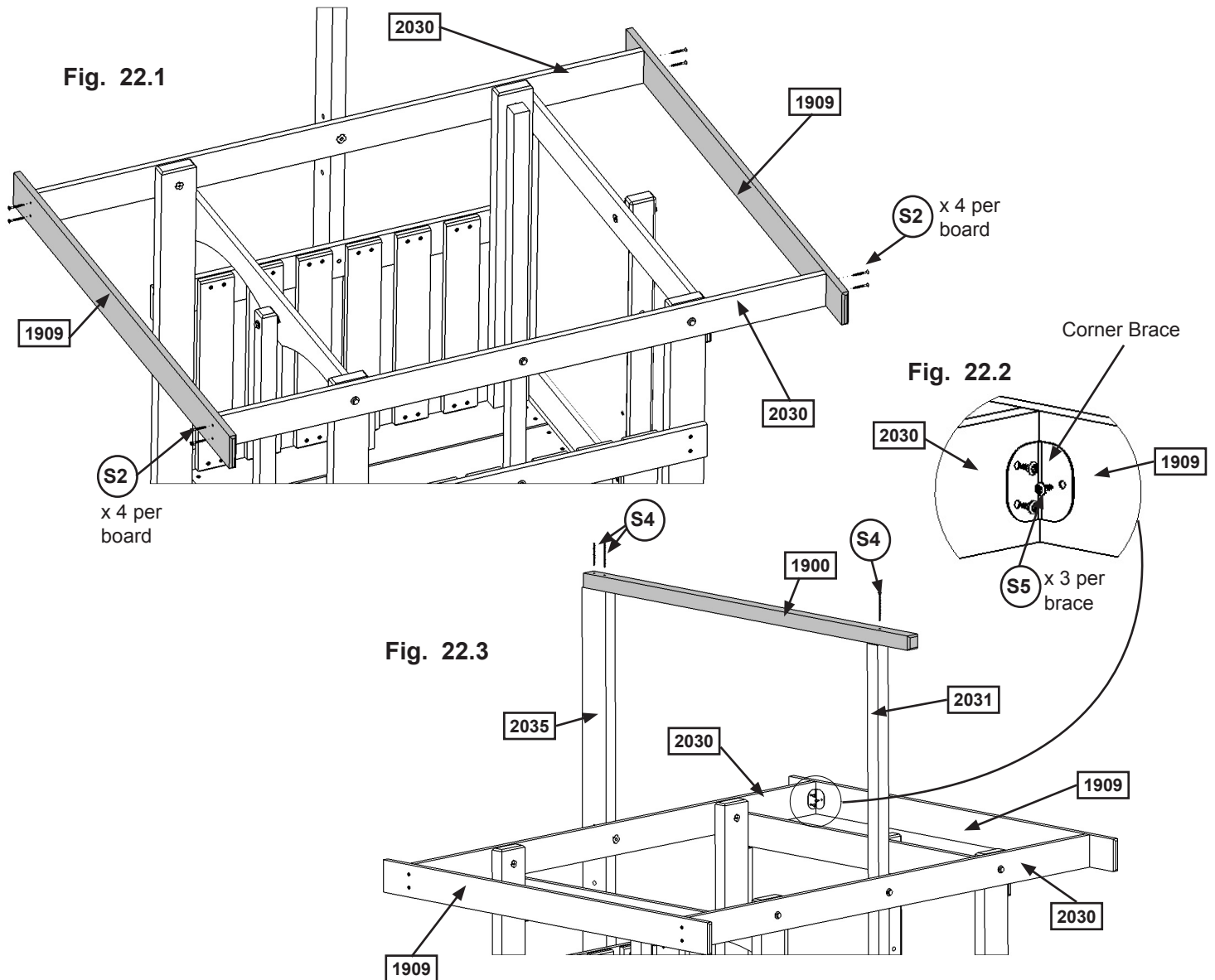

Wood Parts

- 1 x 1900 Ridge 2 x 2 x 46-3/4"
- 2 x 1909 Tarp Front Back 1 x 4 x 46-3/4"

Hardware

- 12 x S5 #8 x 1/2" Pan Screw
- 8 x S2 #8 x 1-1/2" Wood Screw
- 3 x S4 #8 x 3" Wood Screw

Other Parts

- 4 x Corner Brace

Step 23: Attach Canopy to Roof Frame

A: Place Canopy over (1900) Ridge making sure bottom edges of tarp are even on both sides of assembly. (fig. 23.1 and 23.2)

B: Secure one side by attaching Canopy to 1 (1909) Tarp Front Back using 5 (S5) #8 x 1/2" Pan Screws (with #8 flat washer). (fig. 23.2)

C: Make sure the Canopy is tight and smooth then secure opposite end of Canopy to (1909) Tarp Front Back using 5 (S5) #8 x 1/2" Pan Screws (with #8 flat washer). (fig. 23.2)

D: Attach Canopy to each end of (1900) Ridge with 2 (S5) #8 x 1/2" Pan Screws (with #8 flat washer). (fig. 23.2)

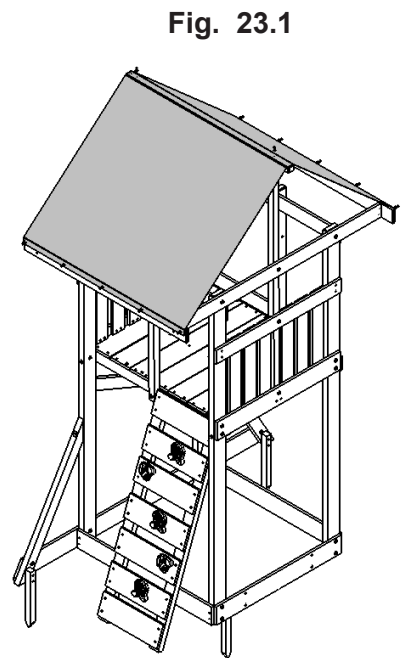
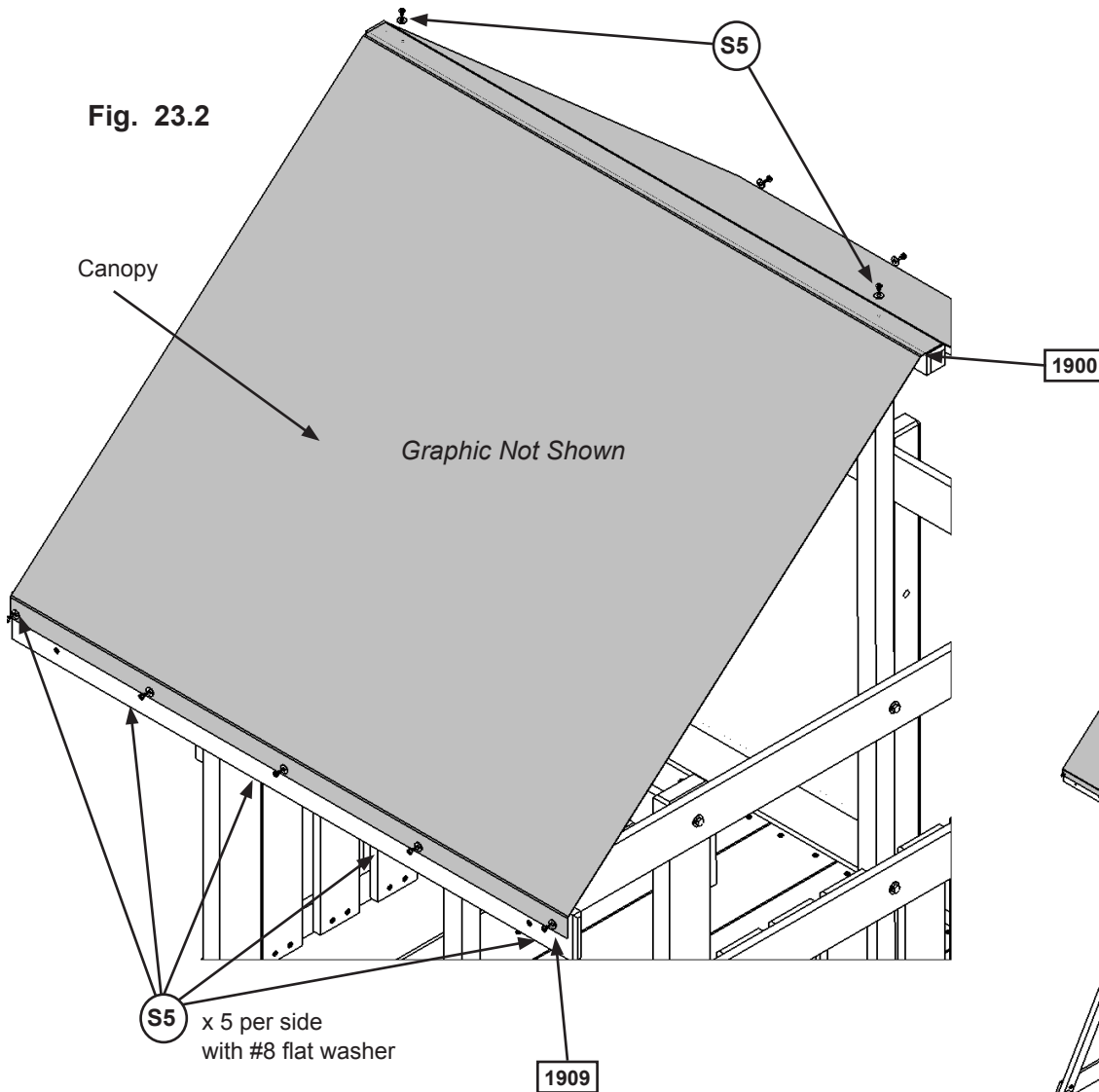

Hardware
12 x  #8 x 1/2" Pan Screw (with #8 flat washer)

Other Parts
1 x Canopy

Step 24: Connect Monkey Bar Assembly to Fort



Pre-drill all pilot holes using a 1/8" drill bit before installing the lag screws.

A: With a MK Bracket attach (9531) MK Rail Short to (2033) MK Mount with 1 (G10) 5/16 x 3" Hex Bolt (with lock washer, flat washer and t-nut) and 4 (S6) #12 x 1" Pan Screws, as shown in fig. 24.1 and 24.2.

B: Measure 21-1/2" from top of (9533) MK Rail Long to top of (1890) CE Gap Board, then with a MB Mount Strap attach (9533) MK Rail Long to (1931) Post using 1 (LS2) 1/4 x 2-1/2" Lag Screw (with flat washer) in the centre hole and 2 (S6) #12 x 1" Pan Screws in the 2 end holes as shown in fig. 24.3.

C: Tighten the top bolt in (2033) MK Mount.

D: Make sure (1227) CE Wall Board, from Step 18 is tight to the floor boards, then attach to (2033) MK Mount using 2 (S2) #8 x 1-1/2" Wood Screws. (fig. 24.4 and 24.5)

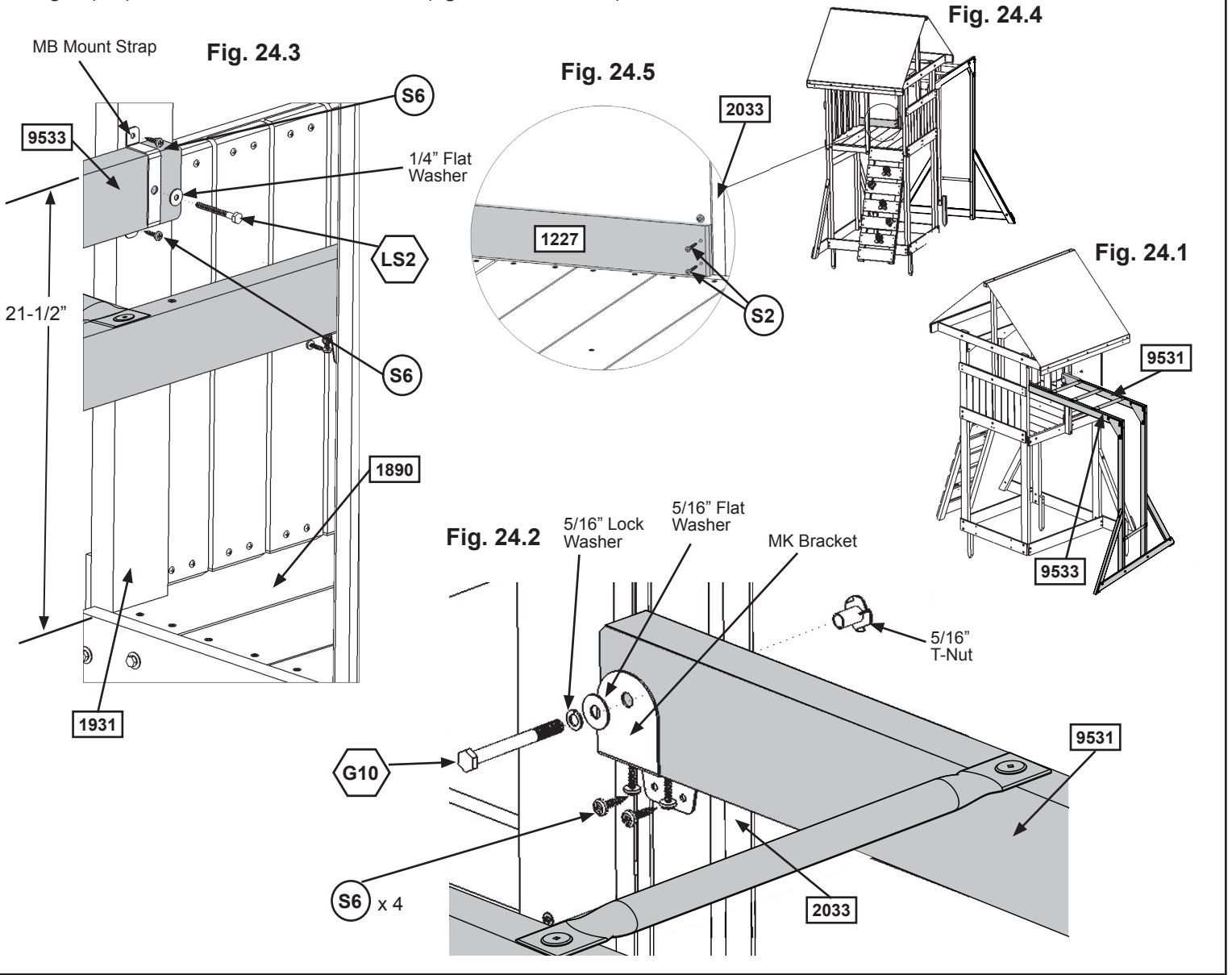

Hardware

- 2 x (S2) #8 x 1-1/2" Wood Screw
- 6 x (S6) #12 x 1" Pan Screw
- 1 x (G10) 5/16 x 3" Hex Bolt (5/16" lock washer, 5/16" flat washer, 5/16" t-nut)
- 1 x (LS2) 1/4 x 2-1/2" Lag Screw (1/4" flat washer)

Other Parts

- 1 x MB Mount Strap
- 1 x MK Bracket

Step 25: Attach Monkey End Ground Stake



A: Drive 1 (0318) Ground Stake 10-1/2" into the ground at one (9530) Post MK on the inside of the assembly and attach with 2 (S3) #8 x 2-1/2" Wood Screws. (fig. 25.1 & 25.2)



Warning! To prevent tipping and avoid potential injury, stakes must be driven 10-1/2" into ground. Digging or driving stakes can be dangerous if you do not check first for underground wiring, cables or gas lines.

Fig. 25.2

Fig. 25.1

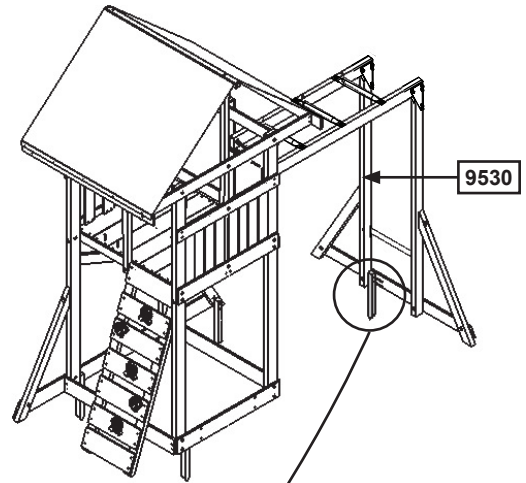
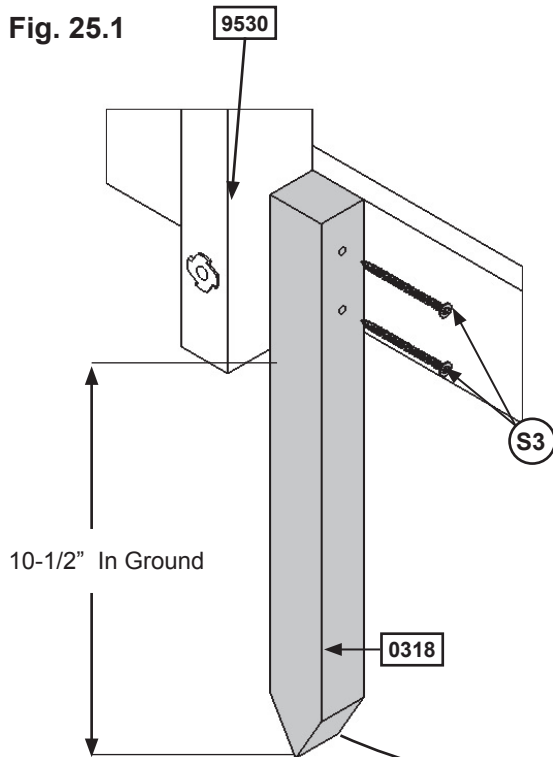

Wood Parts

1 x 0318 Ground Stake 1-1/4 x 1-1/2 x 14"

Hardware

2 x S3 #8 x 2-1/2" Wood Screw

Step 26: Attach Slide to Fort



Note: Pre-drill all holes using a 1/8" drill bit before installing the pan screws.

A: Place Slide in the centre between (1937) Centre Divider and (1931) Post. (fig. 26.1 and 26.2)

B: Attach slide to fort through the floor boards and into (1908) Front Floor using 3 (S7) #12 x 2" Pan Screws. (fig. 26.2 & 26.3)

Fig. 26.3

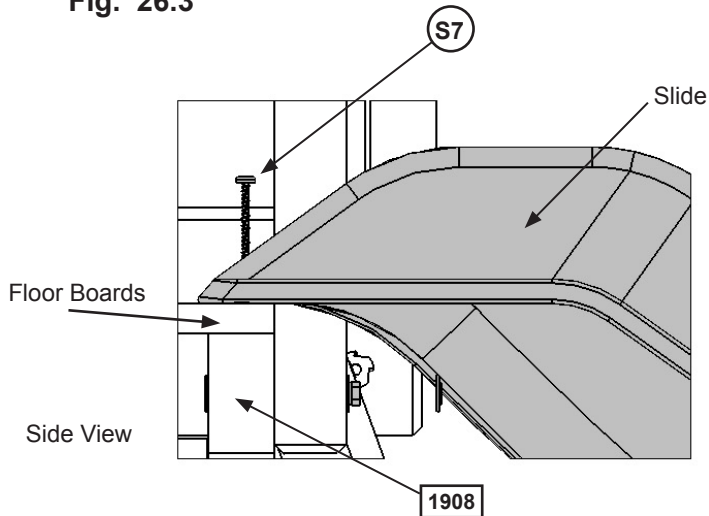

Fig. 26.1

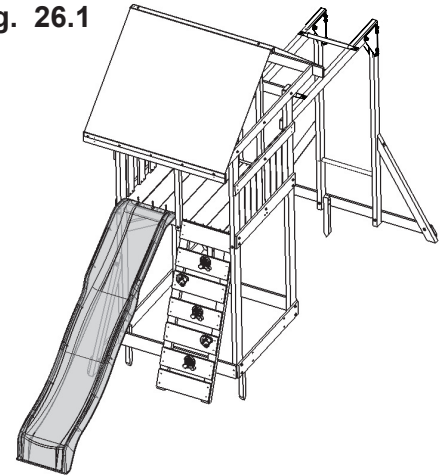
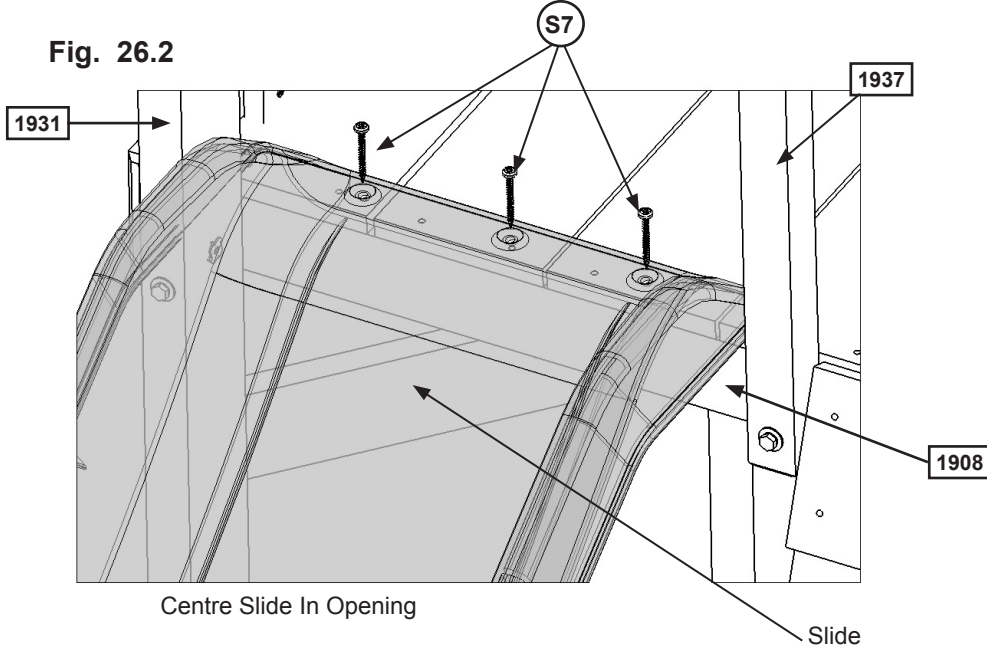

Fig. 26.2



Hardware
3 x (S7) #12 x 2" Pan Screw

Other Parts
1 x Slide

Step 27: Attach Cafe Canopy to Fort



A: Feed Cafe Canopy Frame through the pocket of the Cafe Canopy. (fig. 27.1)

B: With a helper, hold the Cafe Canopy Frame 3-1/4" down from bottom of (2032) End Floor, against both (1931) Posts on the Cafe Wall side of the assembly then attach with 1 (S6) #12 x 1" Pan Screw per post.. (fig. 27.2 and 27.3)

C: Make sure the Cafe Canopy is smooth and tight then attach to the top of (2032) End Floor with 5 evenly spaced (S5) #8 x 1/2" Pan Screws (with #8 flat washer) as shown in fig. 27.4. On each side of the Cafe Canopy measure 1" down from the top of (2032) End Floor and 1/2" in from the edge of the canopy, then install 1 (S5) #8 x 1/2" Pan Screw (with #8 flat washer) to each side. (fig. 27.4)

Fig. 27.1

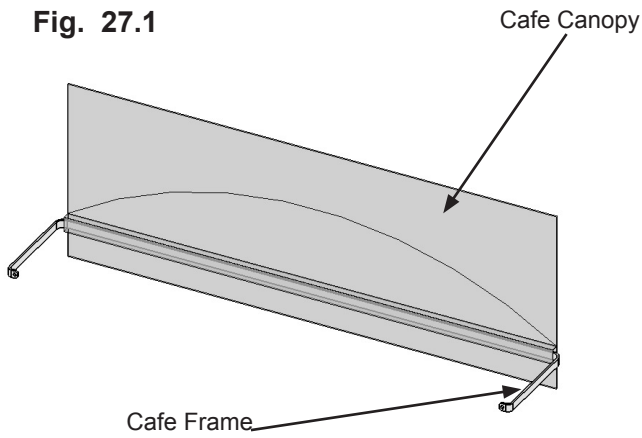

with #8 flat washer

Fig. 27.4

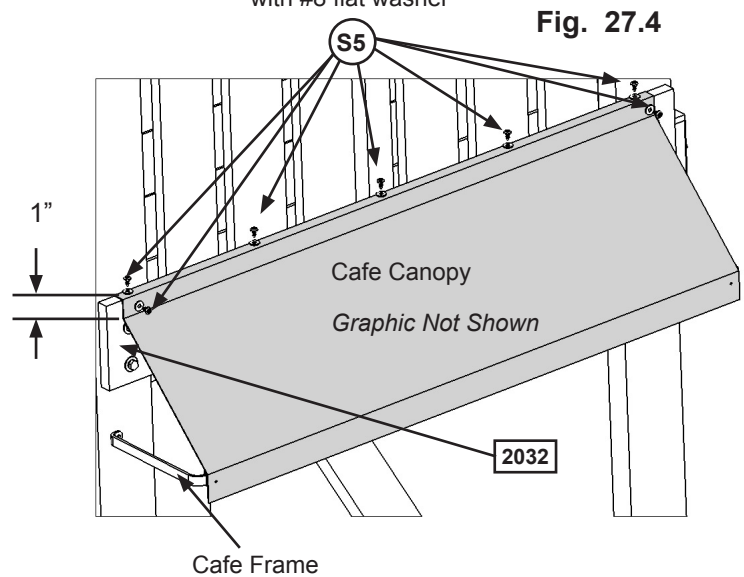
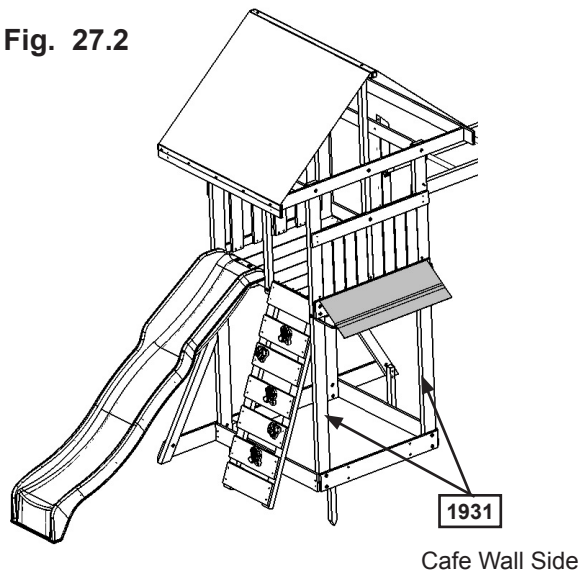
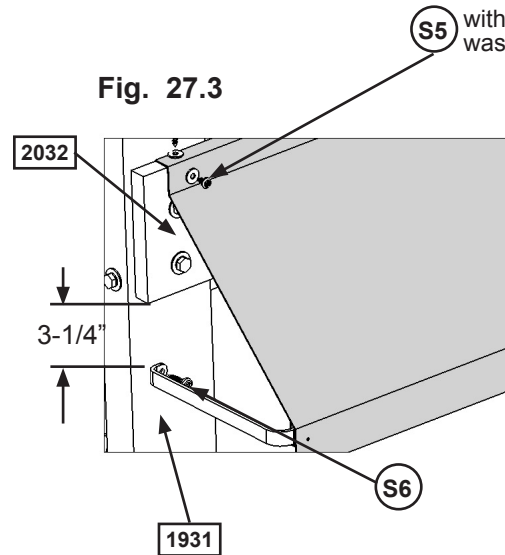

Fig. 27.2



(S5) with #8 flat washer

Fig. 27.3



Hardware

7 x (S5) #8 x 1/2" Pan Screw (#8 flat washer)

2 x (S6) #12 x 1" Pan Screw

Other Parts

1 x Cafe Canopy Frame

1 x Cafe Canopy

Step 28: Cafe Wall Assembly Part 1

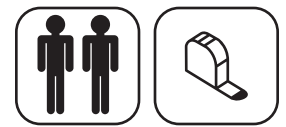

A: Loosen the 4 bolts indicated on (2036) Cafe Ground, in fig. 28.2, then tuck the Brookridge Tarp between the (1931) Posts and (2036) Cafe Ground, down to the top of the bolts, 3/4" from top of board. (fig. 28.1 and 28.2)

B: From outside the assembly, measure 1-1/2" up from the top of (2036) Cafe Ground, on both sides, and attach tarp to both (1931) Posts, 1/2" in from the edge of the tarp, with 2 (S5) #8 x 1/2" Pan Screws (with #8 flat washer). (fig. 28.2)

C: Measure 1-1/2" down from the top of the tarp and attach to both (1931) Posts, 1/2" in from the edge of the tarp, with 2 (S5) #8 x 1/2" Pan Screws (with #8 flat washer). (fig. 28.2)

D: Attach a third (S5) #8 x 1/2" Pan Screw (with #8 flat washer) to each side, 6-5/8" from the first two screws, as shown in fig. 28.2.

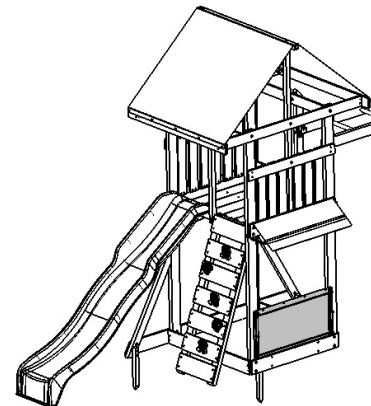
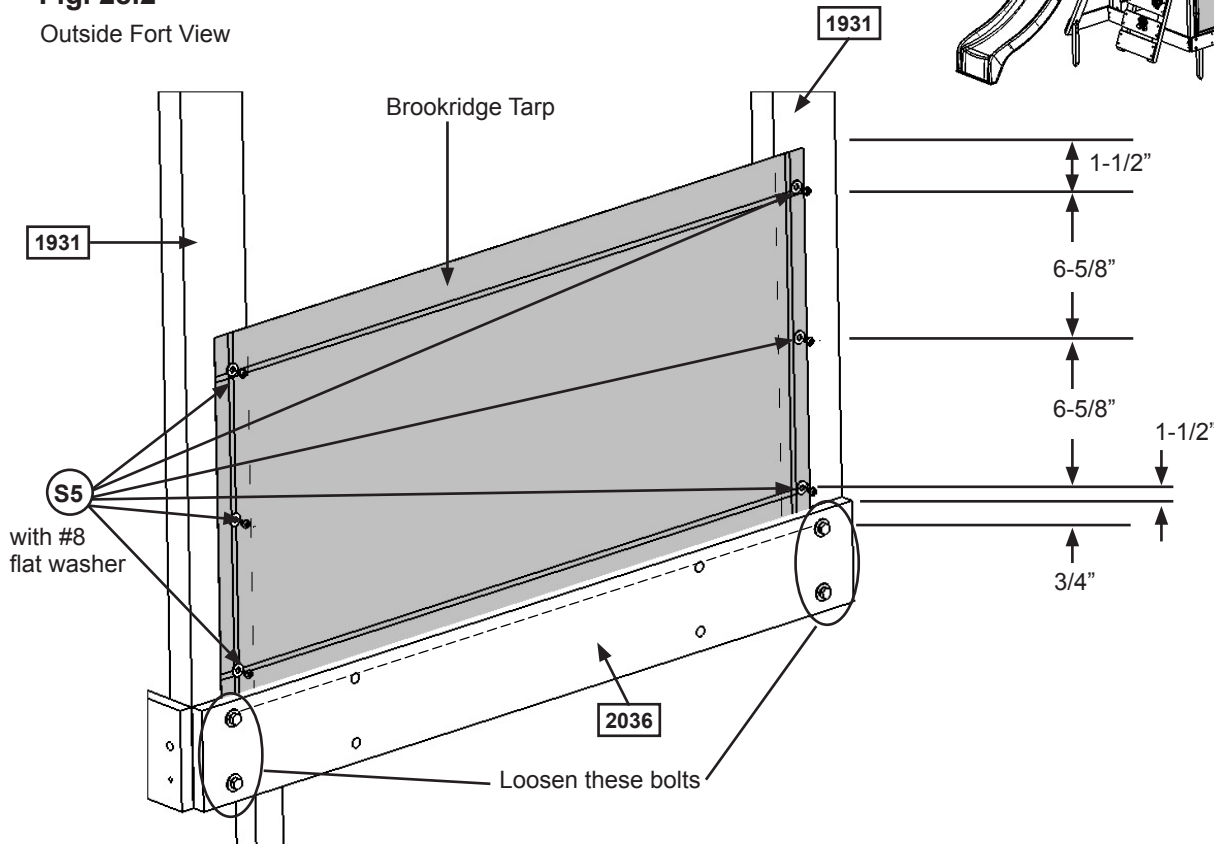

Fig. 28.1

Fig. 28.2

Outside Fort View



Hardware

6 x (S5) #8 x 1/2" Pan Screw (#8 flat washer)

Other Parts

1 x Brookridge Tarp

Step 28: Cafe Wall Assembly Part 2



E: On the outside of the assembly place 1 (1941) Water Sand Support overlapping Brookridge Tarp by 1" and flush to the outside edges of both (1931) Posts. Make sure the board is level then attach with 4 (S3) #8 x 2-1/2" Wood Screws. (fig. 28.3)

F: Attach (2028) Cafe Top tight to the top of (1941) Water Sand Support with 3 (S7) #12 x 2" Pan Screws. Make sure the notched edges are tight to the posts, . (fig. 28.3)

G: From the inside of the assembly and 1/2" in from the edge of the tarp, attach tarp to (2036) Cafe Ground and (1941) Water Sand Support with 4 evenly spaced (S5) #8 x 1/2" Pan Screws (with #8 flat washer) per board. The distance between screws should be 8". (fig. 28.4)

H: Tighen the previously loosened bolts.

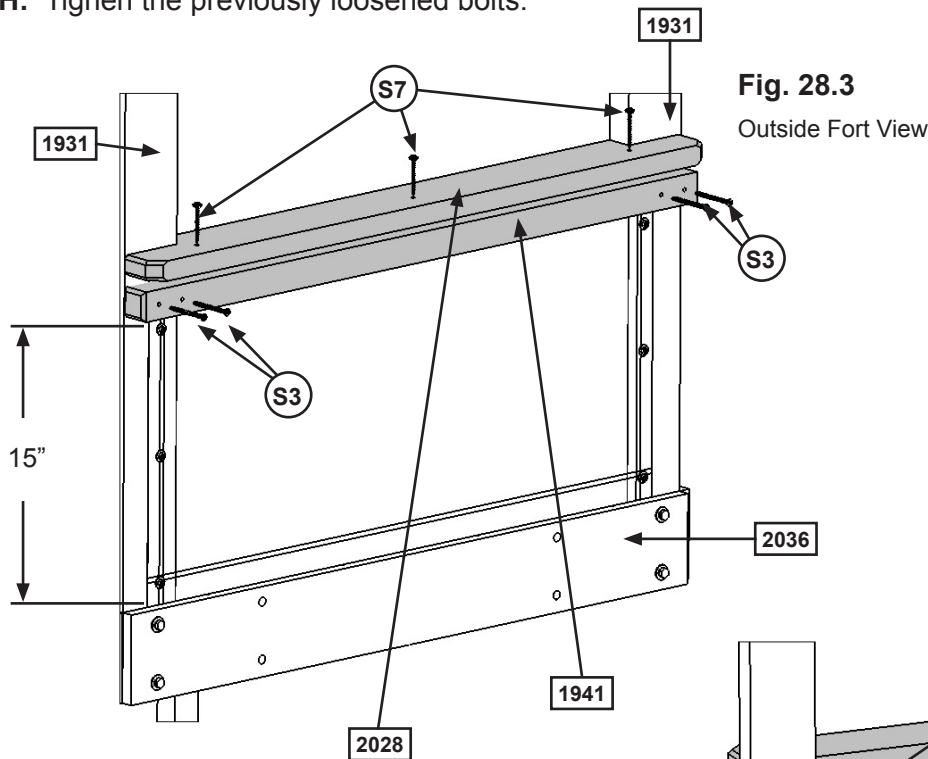

Fig. 28.3
Outside Fort View

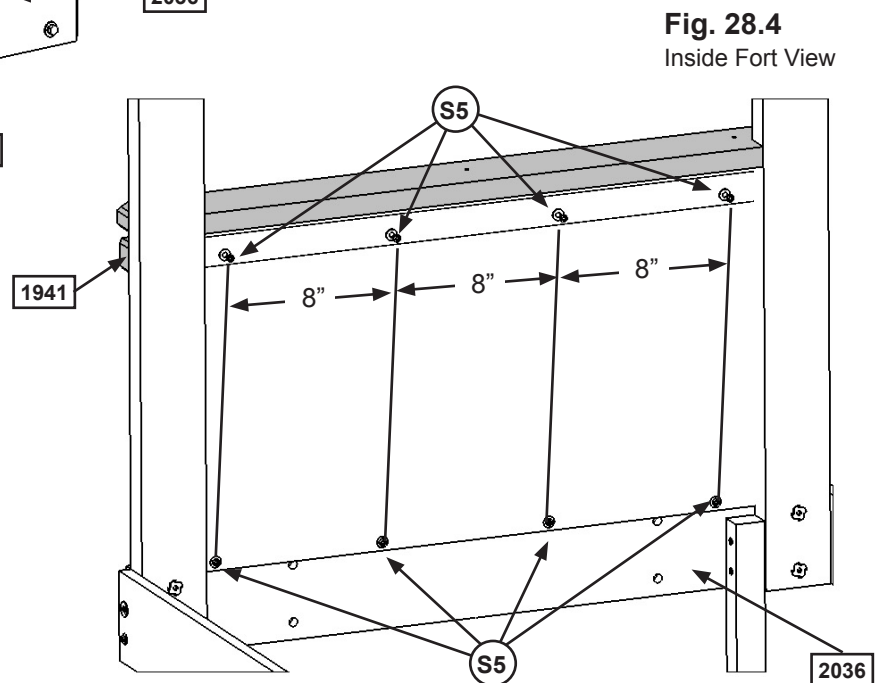

Fig. 28.4
Inside Fort View

Wood Parts

- 1 x [2028] Cafe Top 5/4 x 4 x 35-7/8"
- 1 x [1941] Water Sand Support 2 x 2 x 35-7/8"

Hardware

- 4 x (S3) #8 x 2-1/2" Wood Screw
- 8 x (S5) #8 x 1/2" Pan Screw (#8 flat washer)
- 3 x (S7) #12 x 2" Pan Screw

Step 29: Stool Seat Assembly



A: Using the hardware provided with the Stool Seat Assembly attach 1 Seat to 1 Seat Support and then create a second seat as in fig. 29.1.

B: Keeping the Cross Brace tight to the Seat Assemblies, fasten the Cross Brace to each of the Seat Assemblies using the hardware provided. (fig. 29.2)

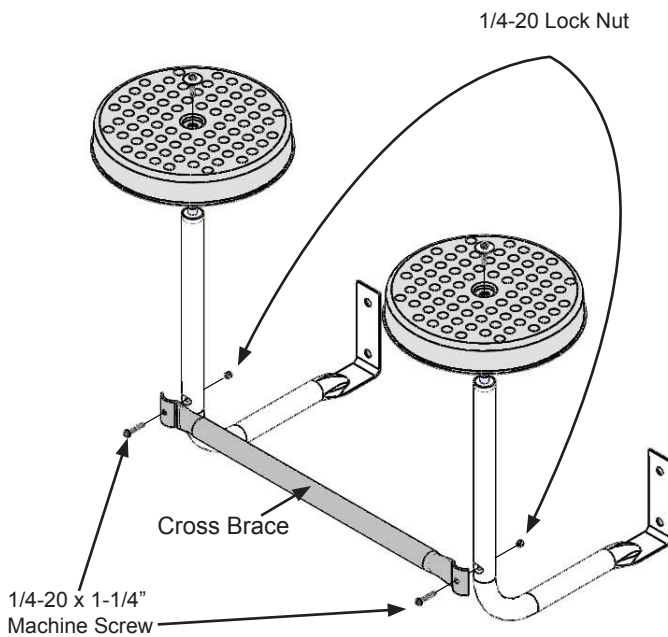
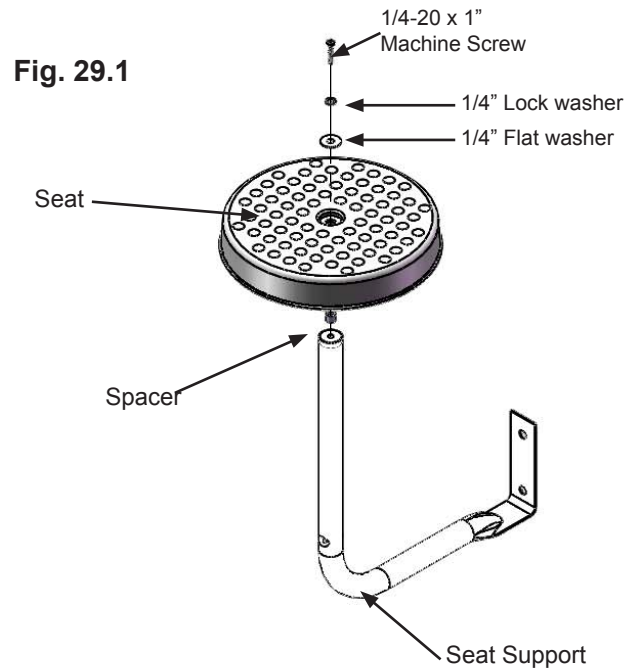

Fig. 29.2

Hardware

2 x 1/4" Lock Washer

Other Parts

1 x Stool Set (with hardware)



Step 30: Attach Stool Seat to Fort

A: Attach the Stool Seat Assembly to (2036) Cafe Ground using 2 (G2) 5/16 x 1" Hex Bolt (with lock washer, flat washer and t-nut) per Seat Assembly. (fig. 30.1 and 30.2)

Fig. 30.1

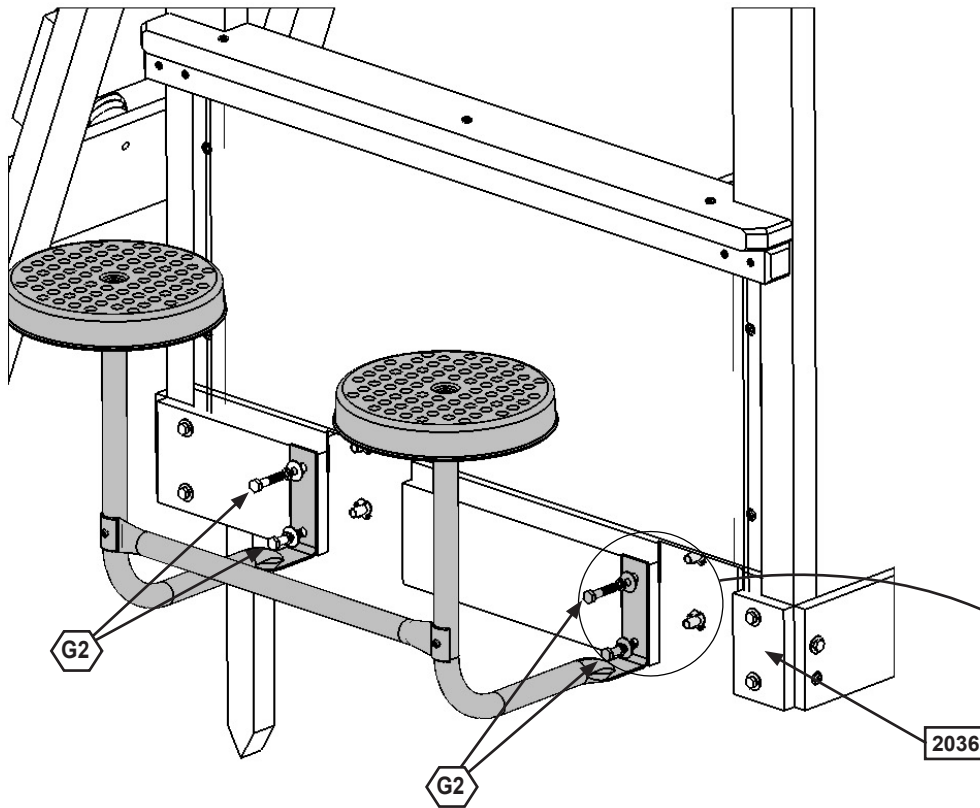

Parts Removed for Clarity

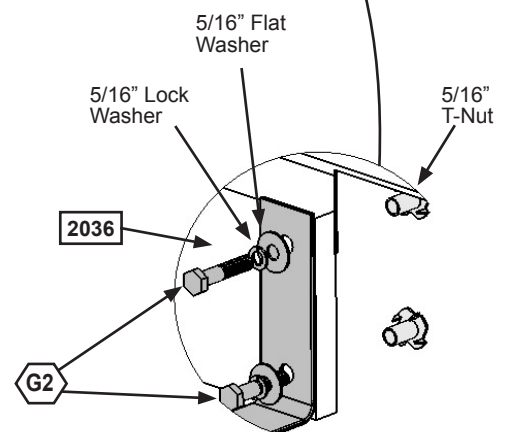

Fig. 30.2

Hardware

4 x G2 5/16 x 1" Hex Bolt
(5/16" lock washer, 5/16" flat washer, 5/16" t-nut)

Step 31: Attach Swing Assembly to Fort



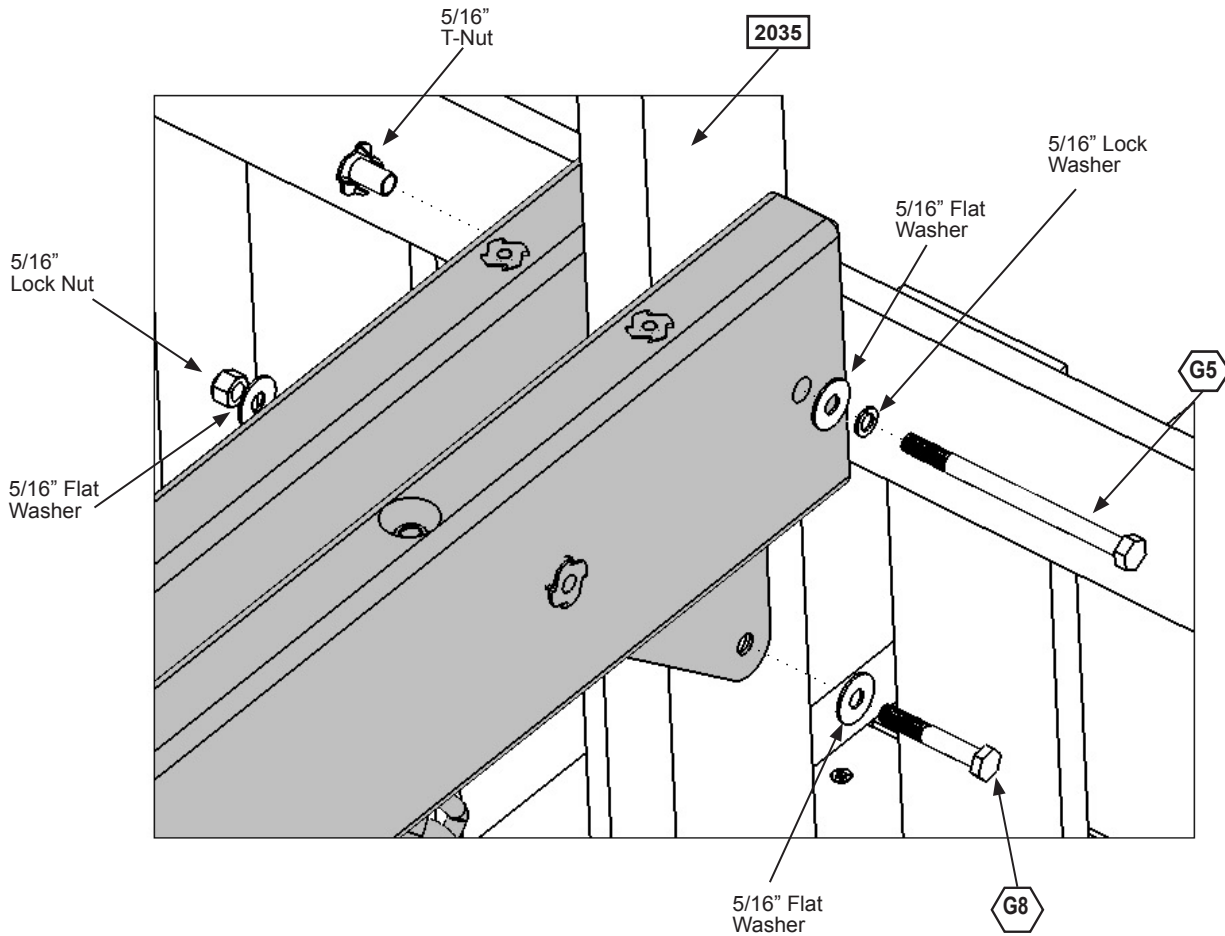

A: Attach Swing Assembly from Step 5 to (2035) SW Mount with 1 (G5) 5/16 x 4-1/2" Hex Bolt (with lock washer, flat washer and t-nut) and 1 (G8) 5/16 x 2" Hex Bolt (with 2 flat washers and 1 lock nut) as shown in fig. 31.1.

Fig. 31.1



Hardware

- 1 x  5/16 x 2" Hex Bolt
(5/16" flat washer x 2, 5/16" lock nut)
- 1 x  5/16 x 4-1/2" Hex Bolt
(5/16" flat washer, 5/16" lock washer, 5/16" t-nut)

Step 32: Attach Swing Ground Stakes

A: Drive one (0318) Ground Stake 10-1/2" into the ground at each (1863) SW Post on the inside of the assembly and attach with 2 (S3) #8 x 2-1/2" Wood Screws per ground stake. (fig. 32.1 and 32.2)



Warning! To prevent tipping and avoid potential injury, stakes must be driven 10-1/2" into ground. Digging or driving stakes can be dangerous if you do not check first for underground wiring, cables or gas lines.

Fig. 32.1

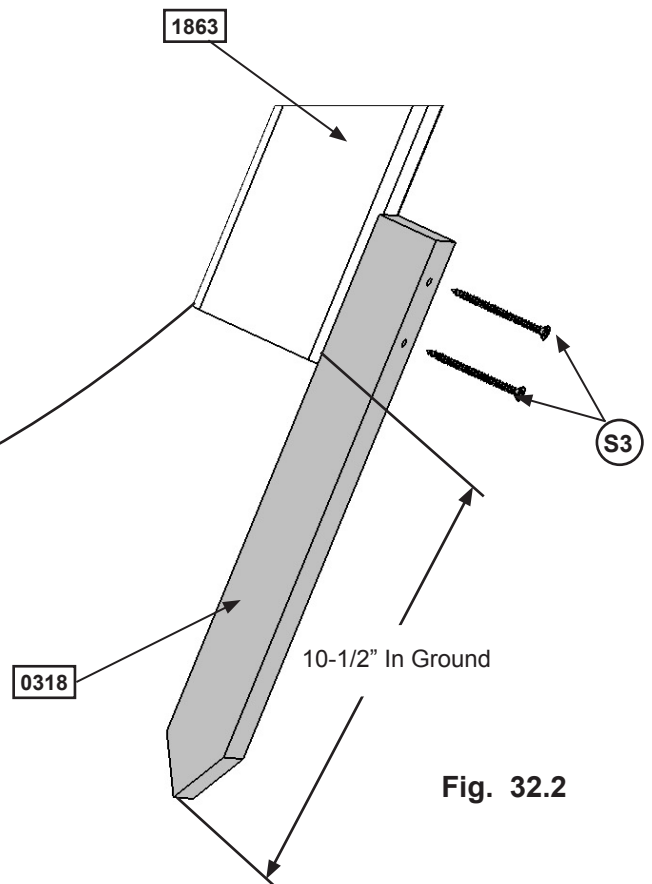
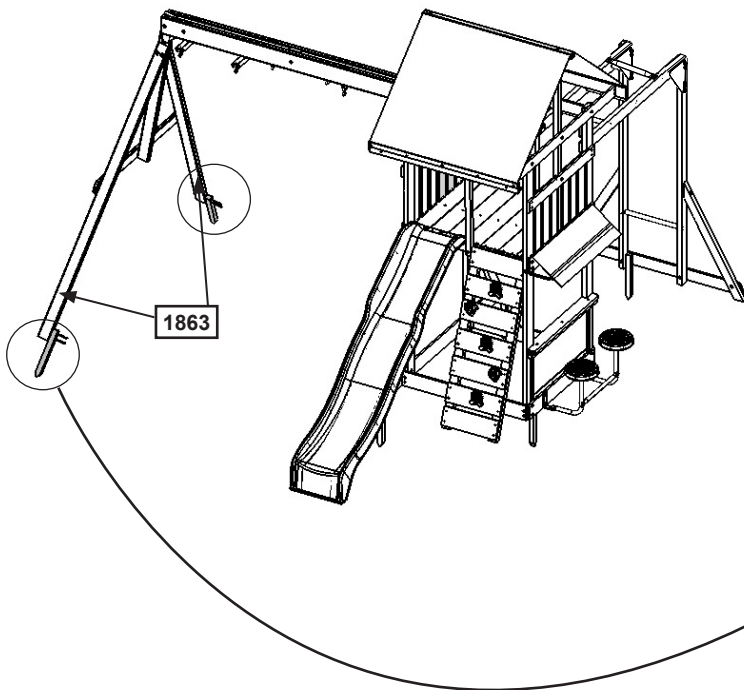

Wood Parts

2 x 0318 Ground Stake 1-1/4 x 1-1/2 x 14"

Hardware

4 x S3 #8 x 2-1/2" Wood Screw

Step 33: Glider Assembly

A: Attach 1 Glider End to the Glider Seat using 1 5/16" Glider Long Hex Bolt (with 2 flat washers and 1 lock nut). Repeat for the second Glider End. (fig. 33.1)

B: Install 2 Glider Rope with Chains into each Glider End using 2 - 5/16" Flat Washers and 1 Lock Nut per rope. (fig. 33.1)

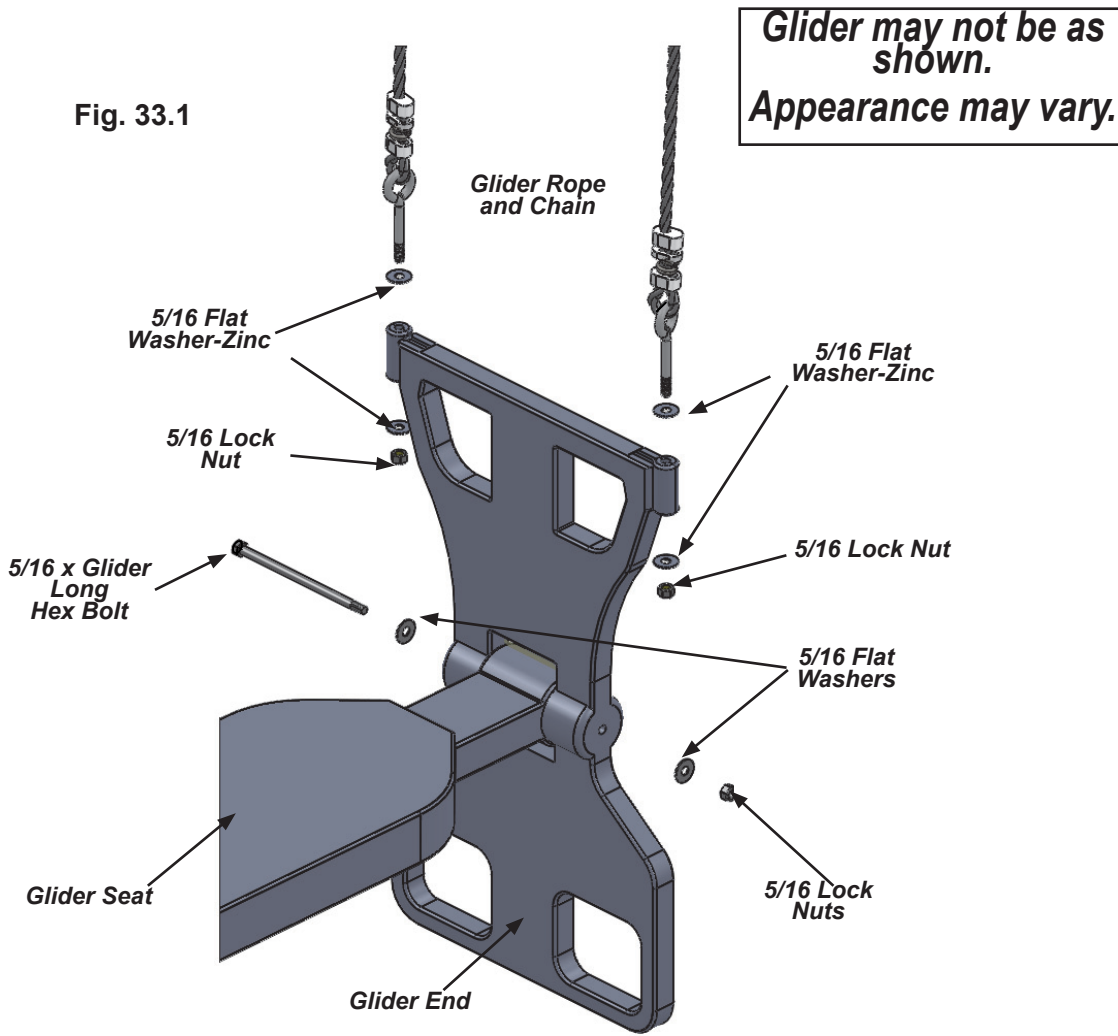

Warning! Bolt must not exceed 1/2 thread past the nut

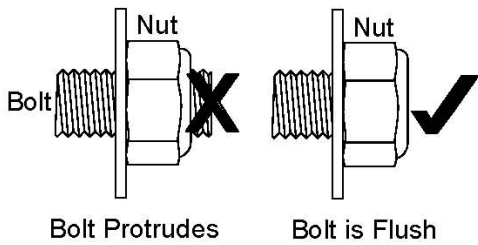

Hardware

- 2 x 5/16" Glider Long Hex Bolt (5/16" flat washer x 2, 5/16" lock nut)
- 8 x 5/16" Flat Washer
- 4 x 5/16" Lock Nut

Other Parts

- 2 x Glider End
- 1 x Glider Seat
- 1 x Glider Rope and Chain (pkg of 4)

Step 34: Attach Accessories to Fort



Warning! Check entire play centre for bolts protruding beyond T-Nuts. Use extra washers to eliminate this condition.

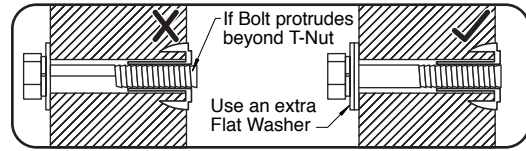

A: Connect the assembled Glider Swing to the Glider Hangers previously installed. (fig. 34.1)

B: Attach 2 Belt Swings to the Bolt-Thru Swing Hangers. (fig. 34.1)

C: Attach 1 Telescope to (1931) Post on the Monkey Ladder side with 2 (S2) #8 x 1-1/2" Wood Screws as shown in fig. 34.1 and 34.2 and 34.3.

Fig. 34.1

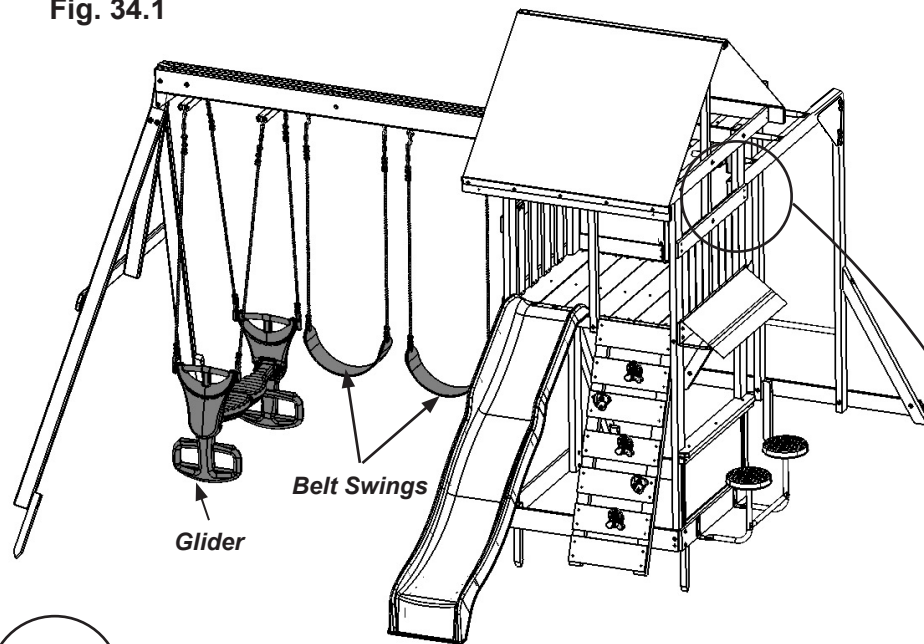

Fig. 34.3

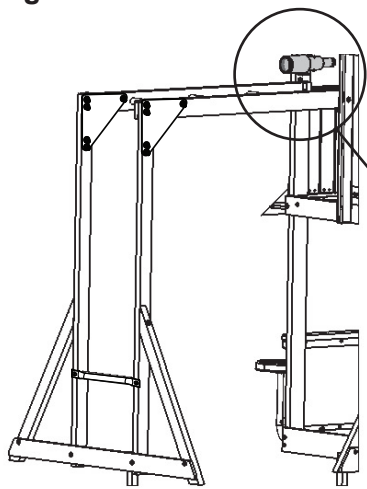
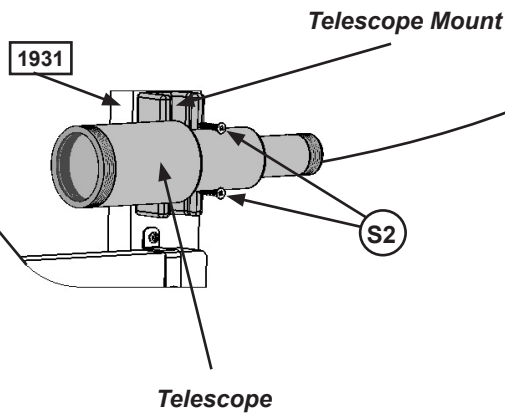



Fig. 34.2



Hardware

2 x  #8 x 1-1/2" Wood Screw

Other Parts

2 x Belt Swings
1 x Telescope

Final Step: Attach I.D. Plaque

ATTACH THIS WARNING & I.D. PLAQUE TO A PROMINENT LOCATION ON YOUR PLAY EQUIPMENT! (Fort or Swing Post)

This provides warnings concerning safety and important contact information. A Tracking Number is provided to allow you to get critical information or order replacement parts for this specific model.

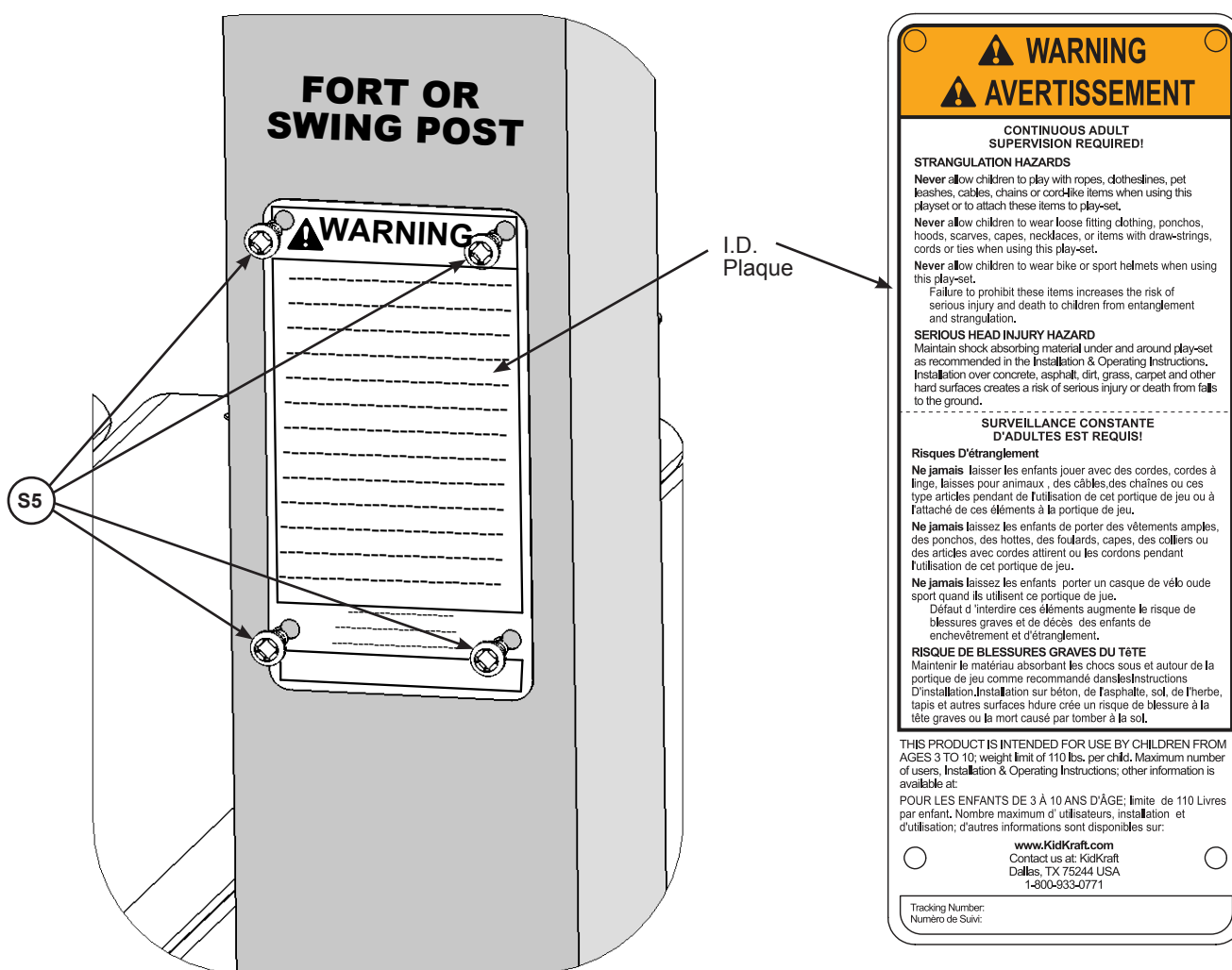

Attach with screws provided to a location on your set that is easily seen and read by a supervising adult.

Hardware
4 x **S5** #8 x 1/2" Pan Screw

Other Parts
1 x KidKraft I.D. Plaque

