

King Headboard

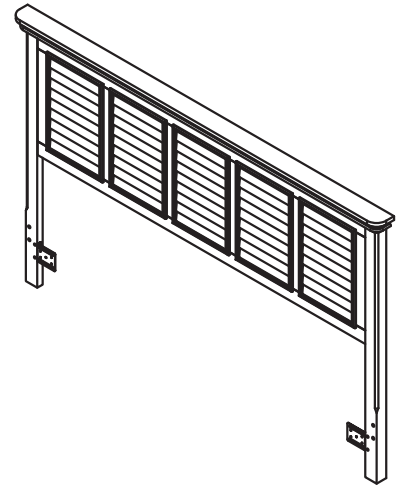

IMPORTANT

Carefully remove all the parts from the carton and place them individually on a soft cloth to prevent scratches or other damage.

Carefully and strictly follow these assembly instructions to ensure a completed product as designed.

Do not use power tools above 8 volts to assemble.

Part List

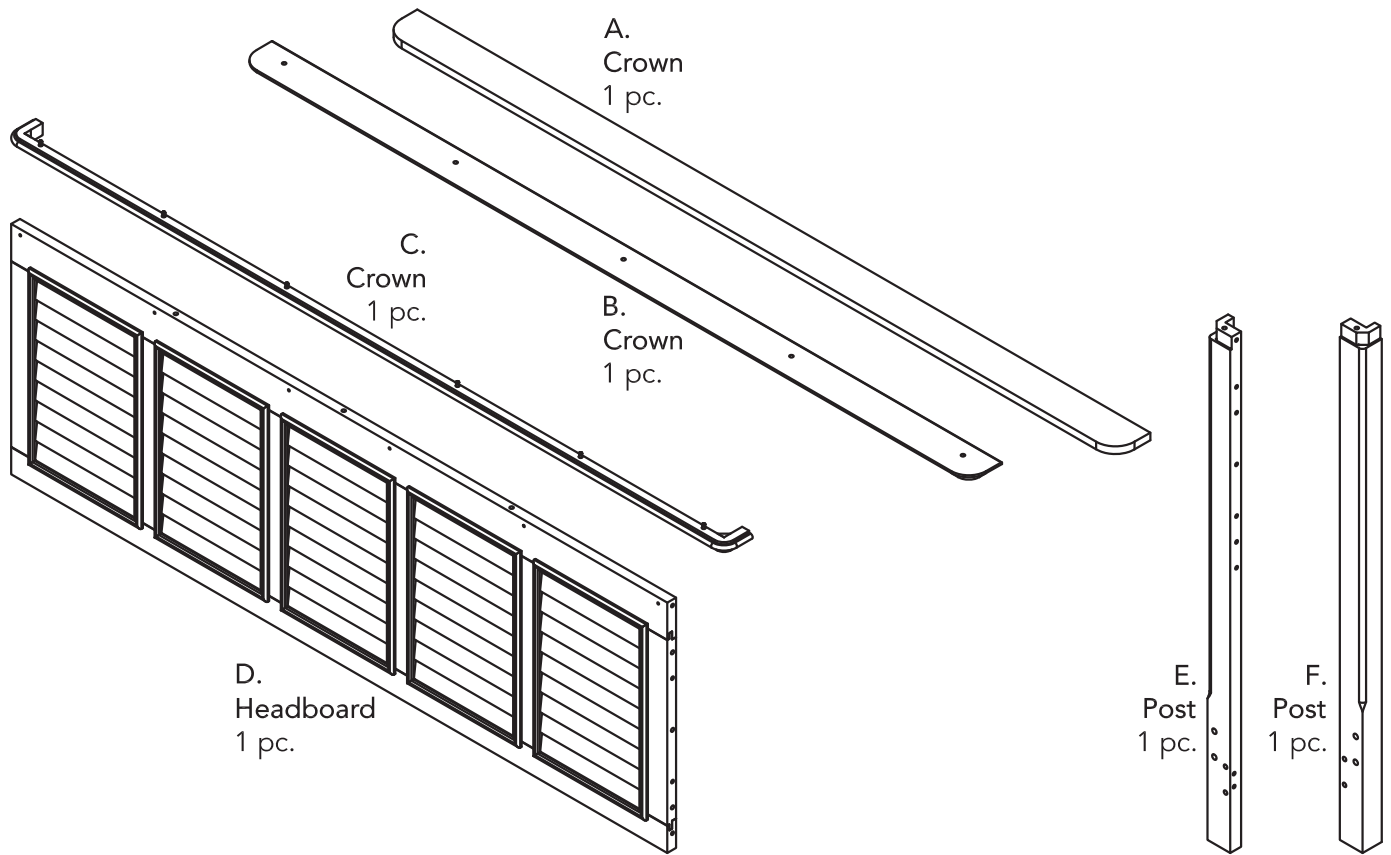

Hardware List

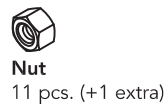
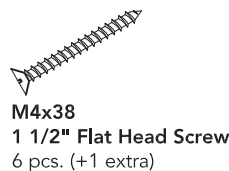
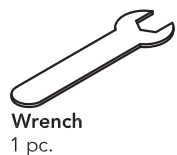

Tool(s) required for assembly: Phillips screwdriver

homestyles Customer Service: www.homestylesfurniture.com,
servicedesk@homestylesfurniture.com, 888-680-7460

Assembly Instructions 2/4

IMPORTANT

- Use a soft cloth between these parts and the floor.
- Do not use power tools above 8 volts to assemble.
- Do not tighten all the bolts until each part is properly assembled.
- Keep Wrench and Hex Wrench as the Nuts and Head Cap Bolts may need to be tightened in the future.

STEP 1

Insert Bolts (long) into pre-drilled holes in Crown (A), then tighten.

Insert Bolts (short) into pre-drilled holes in Posts (E) and (F), then tighten.

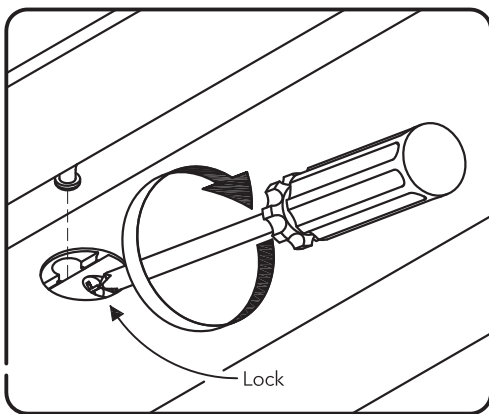
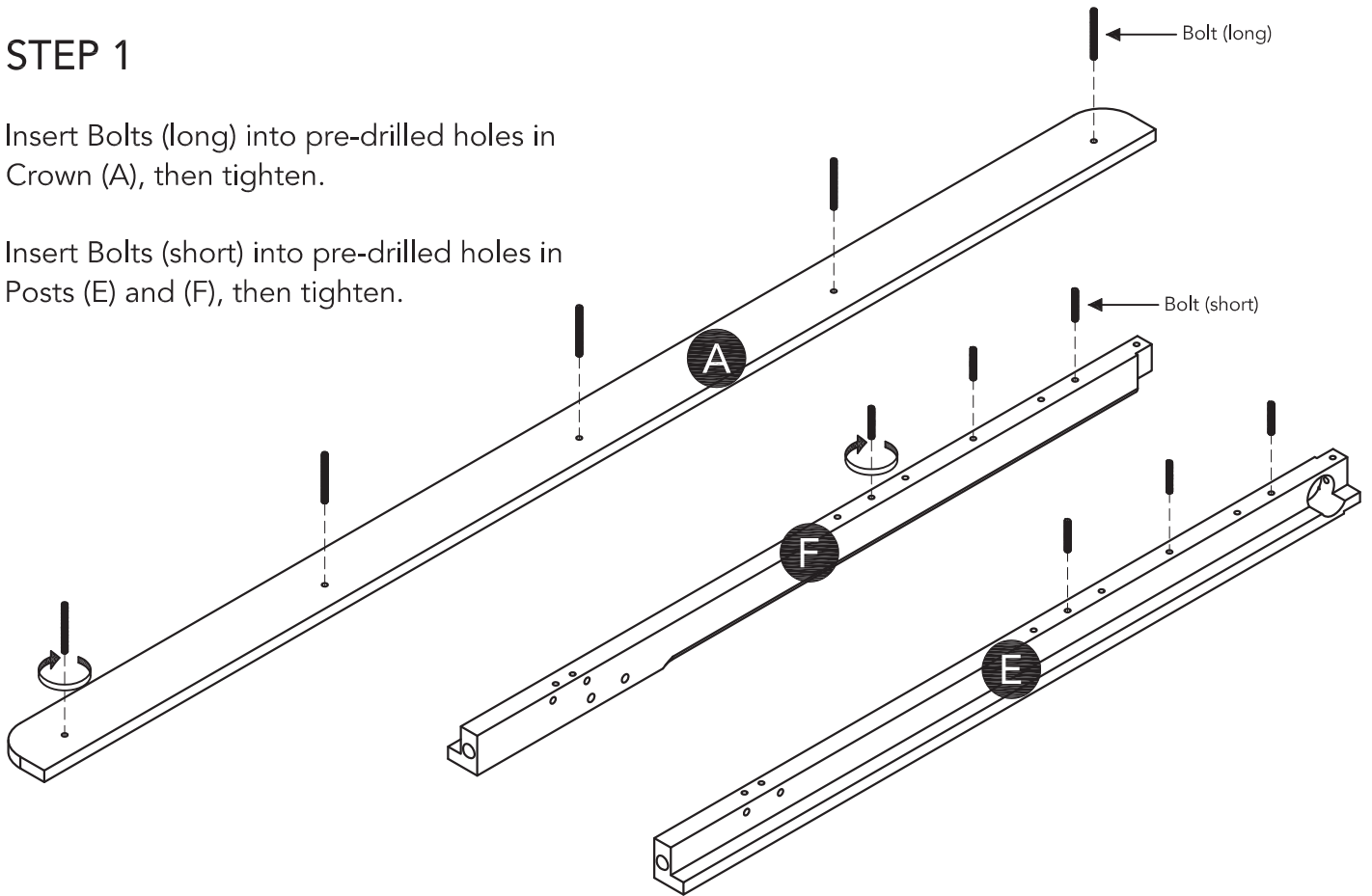
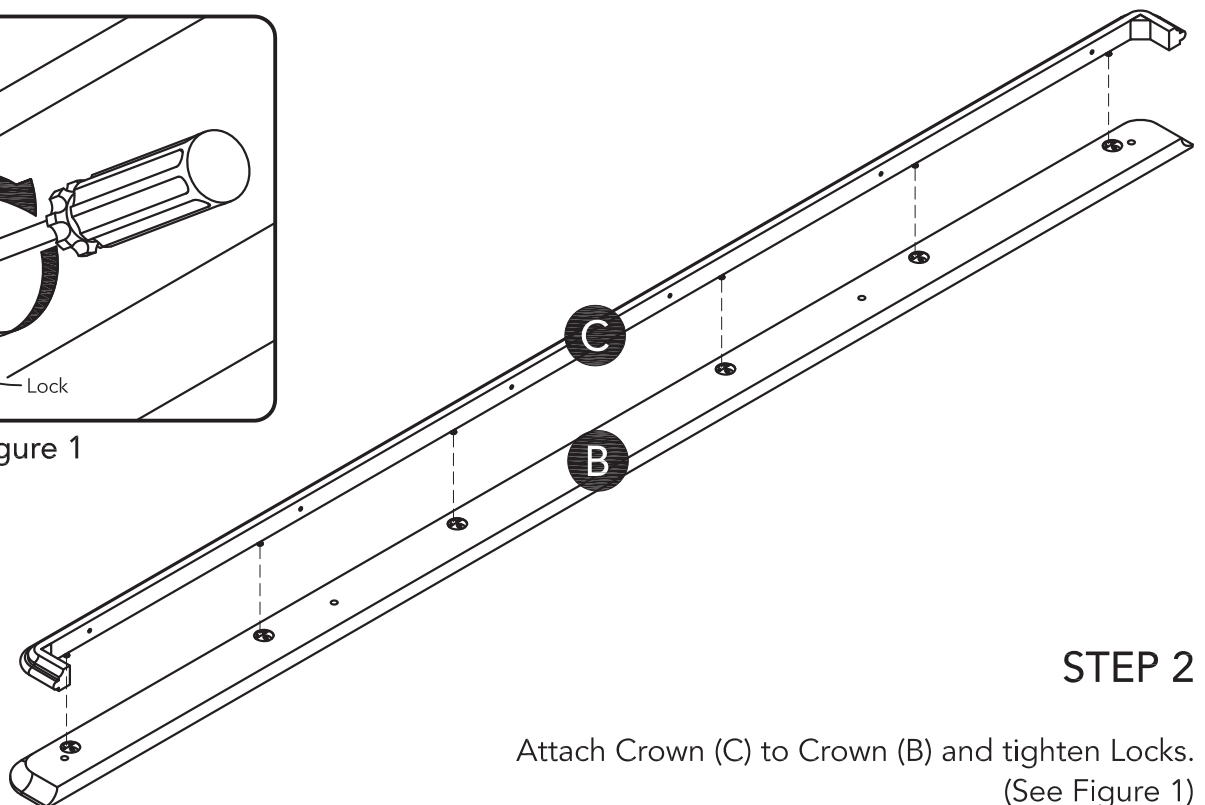

Figure 1



STEP 2

Attach Crown (C) to Crown (B) and tighten Locks.
(See Figure 1)

Assembly Instructions 3/4

STEP 3

Attach Posts (E) and (F) to Headboard (D) with Dowels, Flat Washers, Spring Washers and Nuts.

Tighten all Nuts with Wrench. (See Figure 2)

Attach Corner Plates to unit with Flat Washers, Spring Washers and Head Cap Bolts.

Tighten all Head Cap Bolts with Hex Wrench. (See Figure 3)

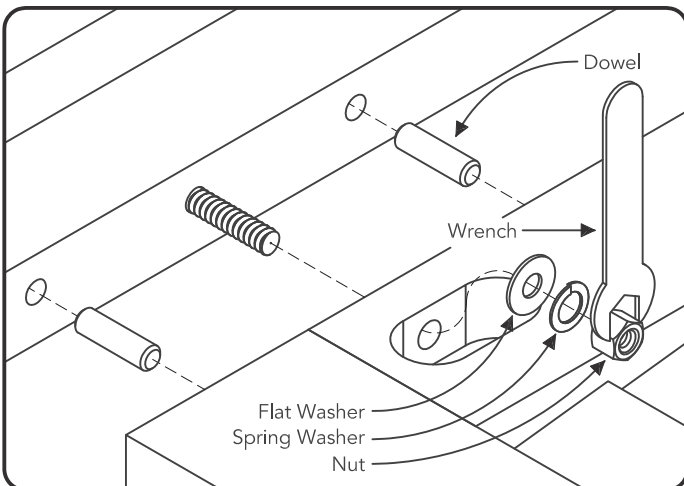
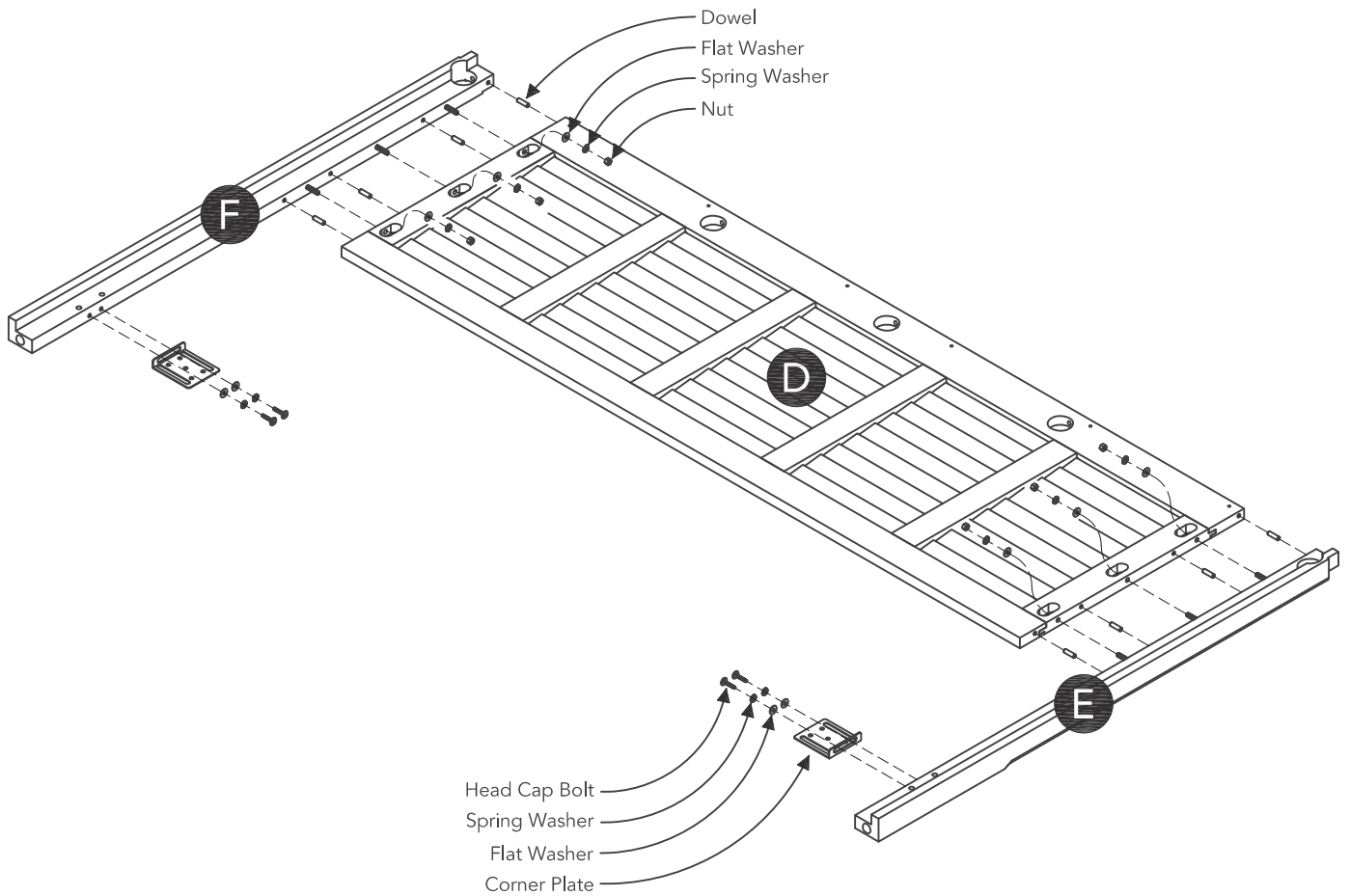

Figure 2

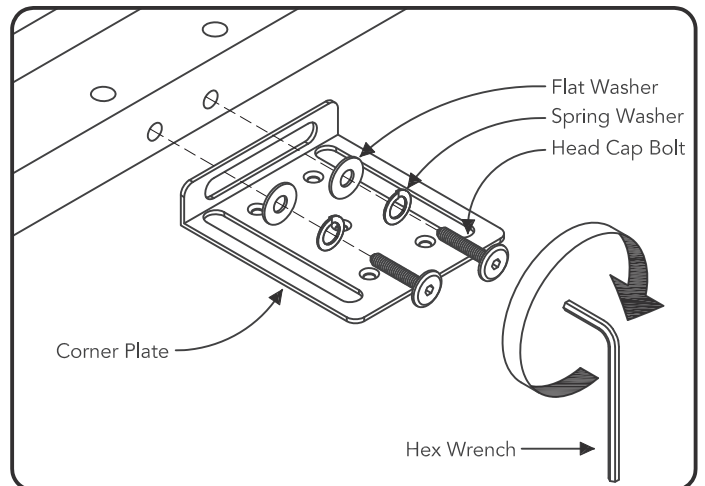

Figure 3

Assembly Instructions 4/4

STEP 4

Attach Crowns (A) and (B) to unit with Flat Washers, Spring Washers and Nuts.

Tighten Nuts with Wrench. (See Figure 2)

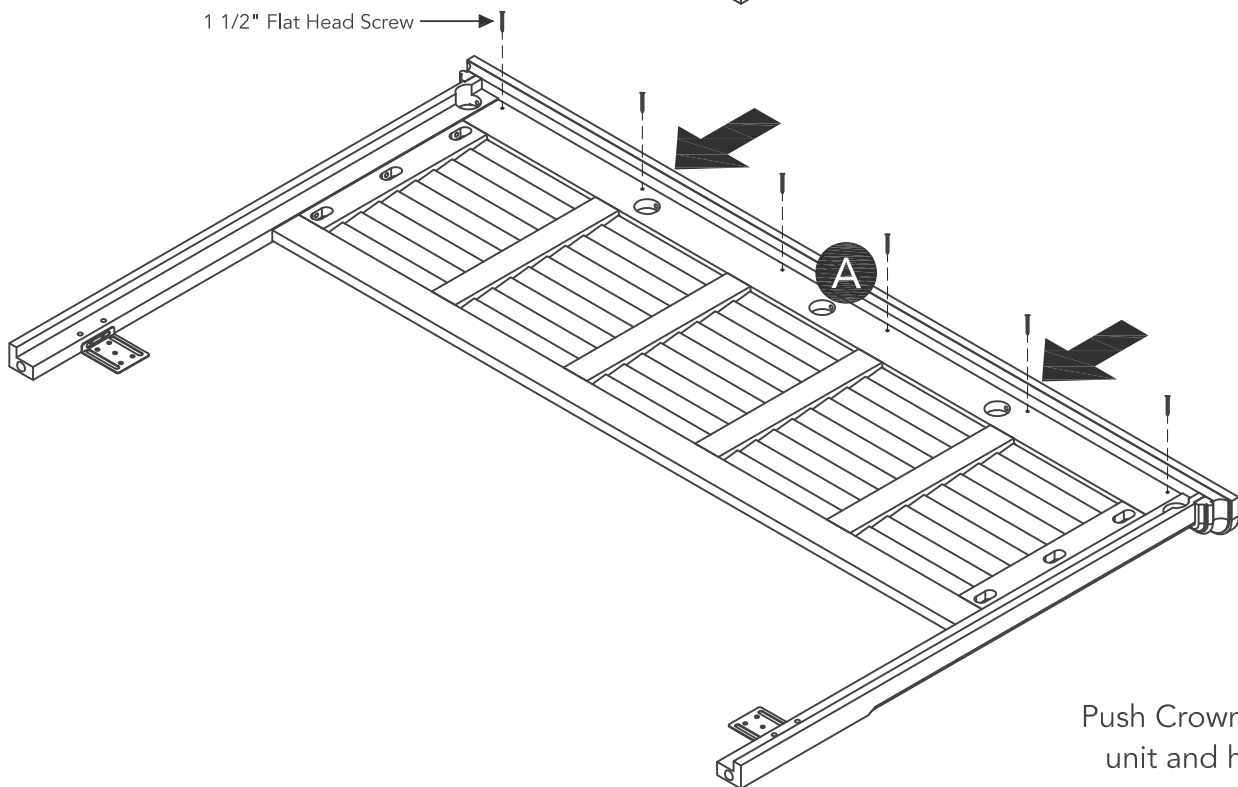
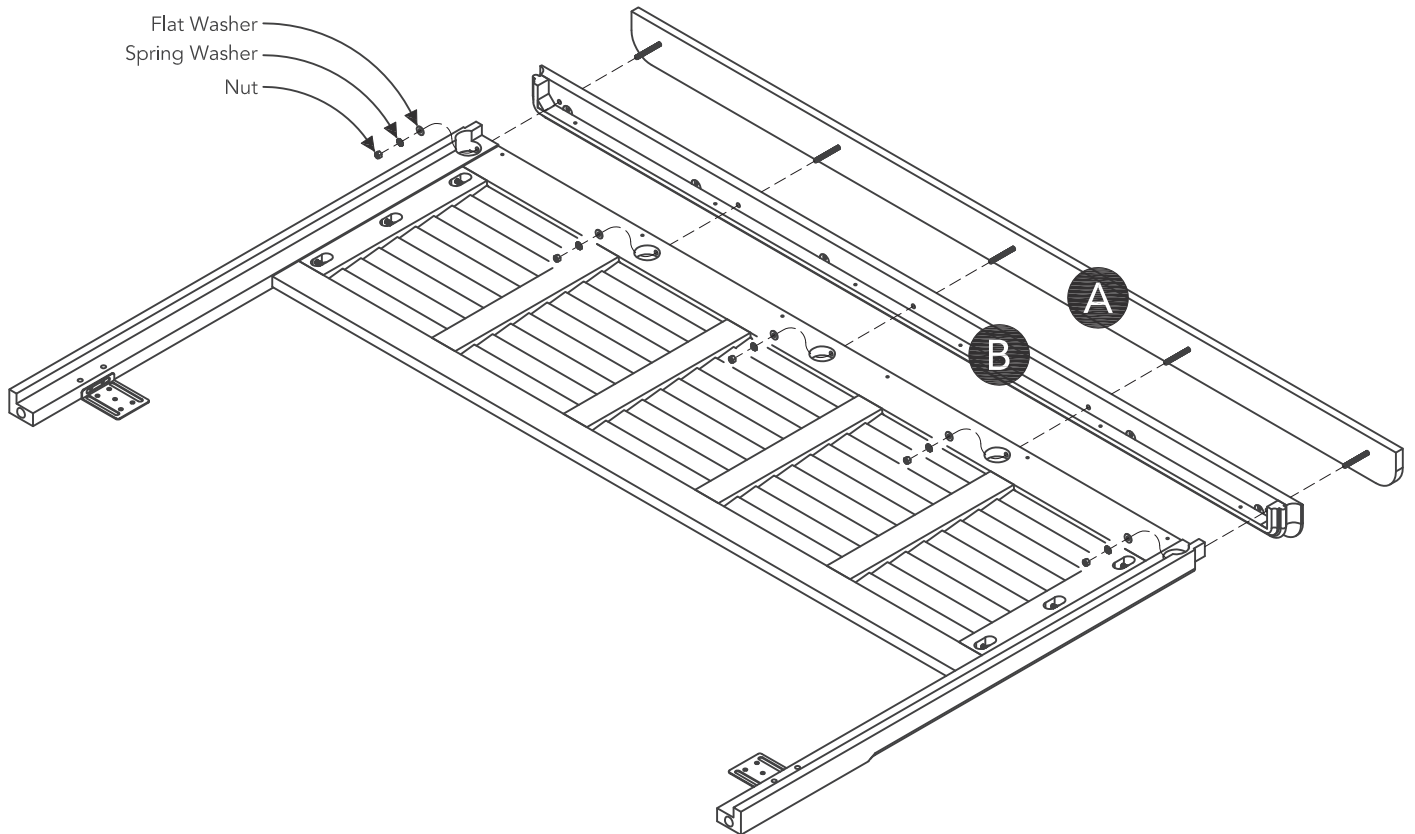

STEP 5

Push Crown (A) firmly to unit and hold in place.

Attach 1 1/2" Flat Head Screws to unit.

CARE INSTRUCTIONS

NEVER

allow liquids to remain on furniture.
Absorption causes parts to warp
and split and finishes to delaminate.

NEVER

use glass cleaners on
finished furniture. Ammonia
chemically attacks the finish.



Do not use power tools
above 8 volts to assemble.

**PREVENT
CRACKING**



Do not place
in direct sunlight.

**PREVENT
FADING**



Do not write
directly on surface.

**PREVENT
MARKING**



Do not place hot
objects on surface.

**PREVENT
FINISH DAMAGE**



Do not use rubber
based placemats.

**PREVENT
DISCOLORING**



Do not use commercial
waxes and polishes.

**PREVENT
YELLOWING**

CLEAN

with a soft cloth moistened
in lukewarm soap and water.
Buff with a dry clean cloth.



homestyles will provide replacements free of charge for missing or damaged parts within 30 days of purchase. Digital images of the defective parts may be required. If the product was not purchased from an authorized retailer, **homestyles** is under no obligation to provide replacement parts. Parts are not available for fully assembled items nor are parts available for sale. Replacements for missing or damaged parts may be requested via contact info below.

homestyles Customer Service: www.homestylesfurniture.com,
servicedesk@homestylesfurniture.com, 888-680-7460