









ASSEMBLY INSTRUCTION

Item: 6072-90851-85 5/0 Uph Headboard
6072-90852-85 5/0 Uph Footboard
6072-90853-85 5/0-6/6 Rails

Thank you for purchasing this quality product. Be sure to unpack carefully looking for small parts which may have come loose during shipment.

Read all instruction and study the drawing carefully before starting the assembly process.

HARDWARE LIST OF HEADBOARD - 90851				
NO.	DESCRIPTION	SIZE	DRAWING	Q'TY
A	HEXAGONAL BOLT	Ø5/16**3-1/4"		2PCS
B	HEXAGONAL BOLT	Ø5/16**1-3/8"		12PCS
C	LOCK WASHER	Ø5/16"		14PCS
D	FLAT WASHER	Ø5/16**19MM		14PCS
E	OPEN WRENCH	13mm		1PC

HARDWARE LIST OF BED RAILS - 90853				
NO.	DESCRIPTION	SIZE	DRAWING	Q'TY
F	THREADED BOLTS	Ø5/16**4"		8PCS
G	HEXAGONAL NUT	Ø5/16"		8PCS
H	CURVED WASHER	Ø5/16"		8PCS
I	OPEN WRENCH	Ø5/16"		1PC

HARDWARE LIST OF FOOTBOARD - 90852				
NO.	DESCRIPTION	SIZE	DRAWING	Q'TY
J	SCREW	8*1-1/4"		8PCS

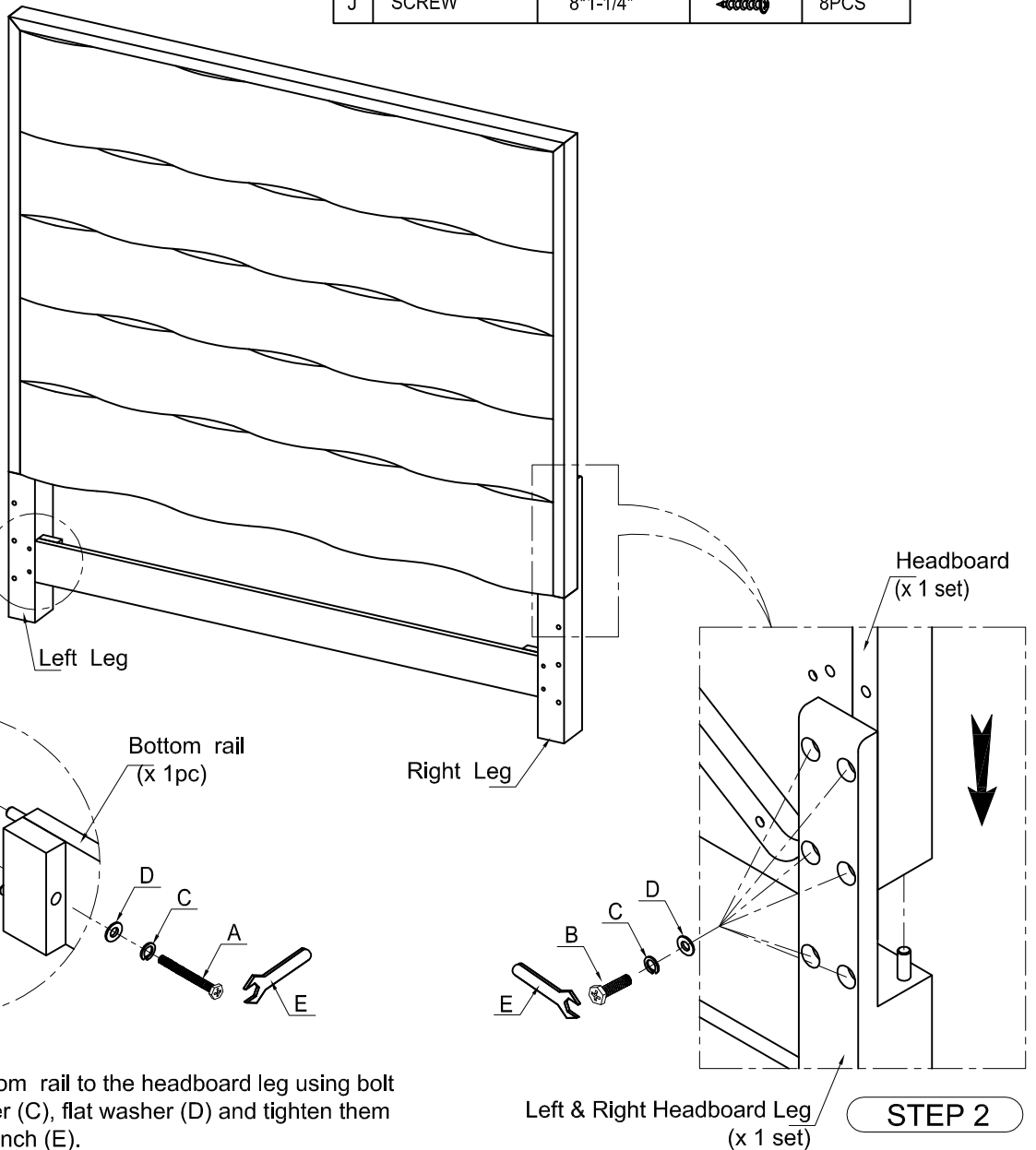

STEP 1. Attach the bottom rail to the headboard leg using bolt (A), lock washer (C), flat washer (D) and tighten them using open wrench (E).

STEP 2. Attach the headboard to headboard leg with flat washer (D), lock washer (C) and bolt (B). Six pieces per leg. Tighten the bolts using open wrench (E).

ASSEMBLY INSTRUCTION

Item: 6072-90851-85 5/0 Uph Headboard
 6072-90852-85 5/0 Uph Footboard
 6072-90853-85 5/0-6/6 Rails

Thank you for purchasing this quality product. Be sure to unpack carefully looking for small parts which may have come loose during shipment.
 Read all instruction and study the drawing carefully before starting the assembly process.

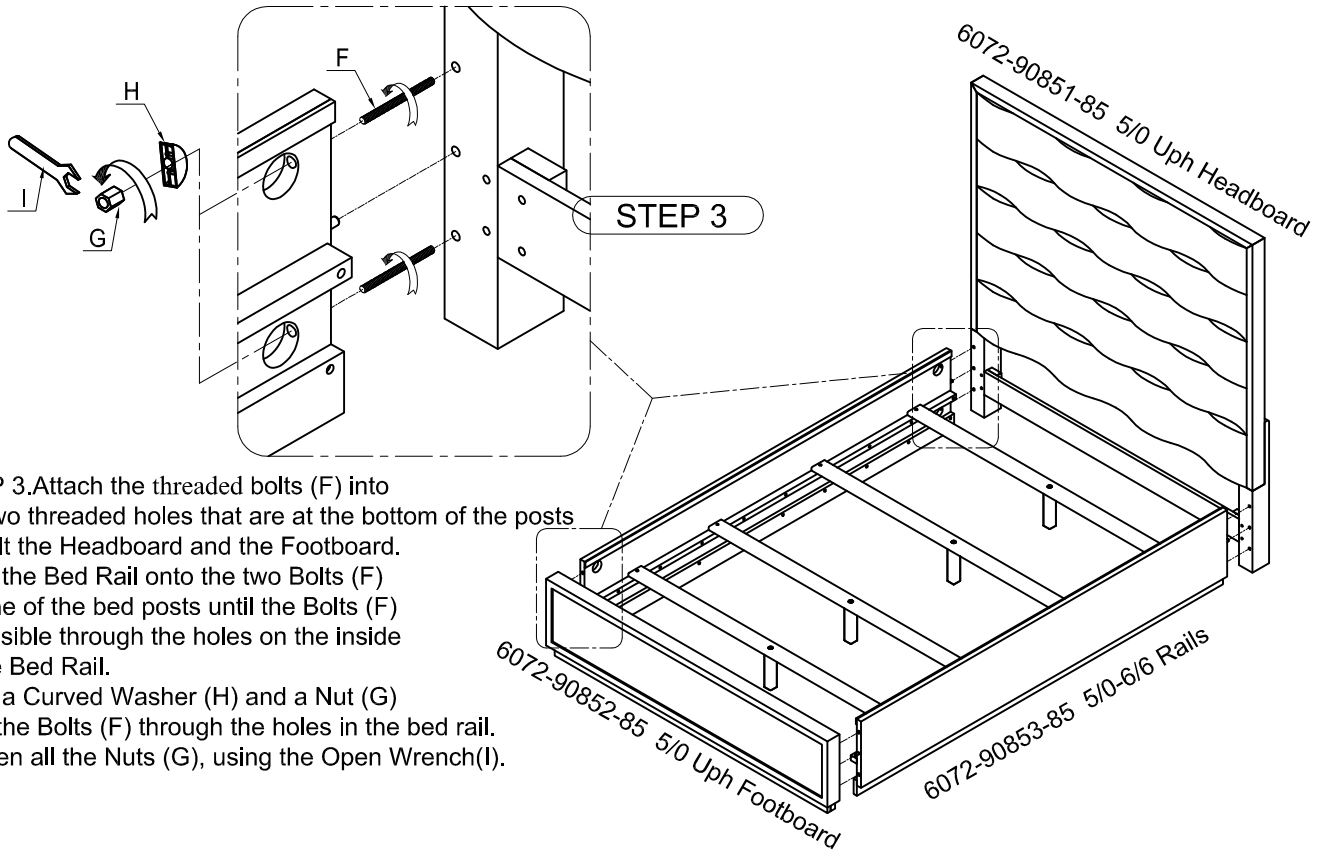

STEP 3: Attach the threaded bolts (F) into the two threaded holes that are at the bottom of the posts of Bolt the Headboard and the Footboard. Slide the Bed Rail onto the two Bolts (F) on one of the bed posts until the Bolts (F) are visible through the holes on the inside of the Bed Rail. Slide a Curved Washer (H) and a Nut (G) onto the Bolts (F) through the holes in the bed rail. Tighten all the Nuts (G), using the Open Wrench(I).

