

## Assembly Instructions, #70002 Folding X desk

### Step 1

Place the desk upside down on a soft surface. Open the velcro strap.

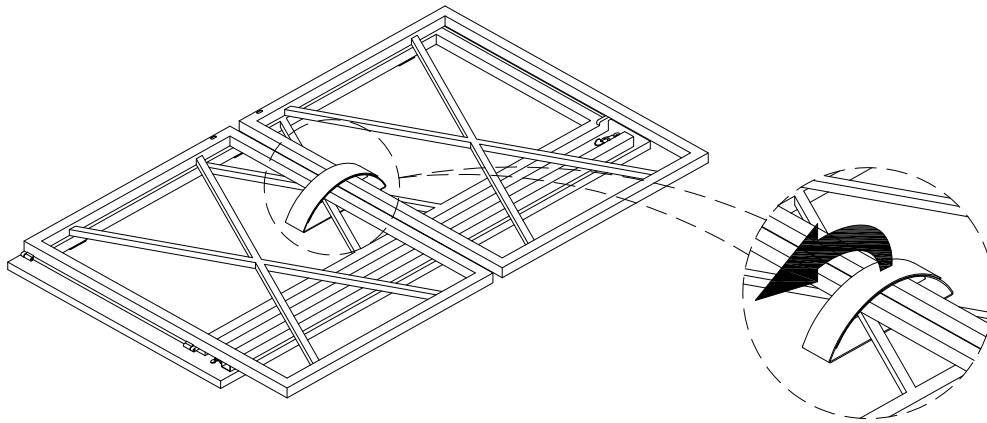

### Step 2

Lift all metal frames into 90 degrees, to make it perpendicular to the bottom surface of the desktop.

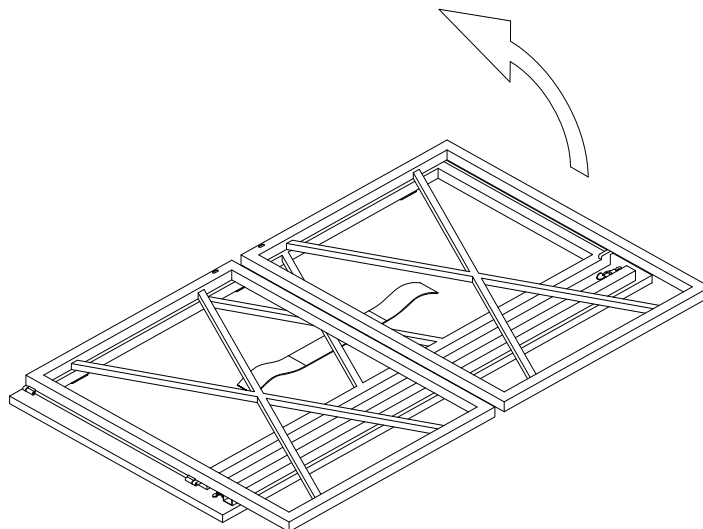

### Step 3

Unfold and rotate two side frames into 270 degrees.

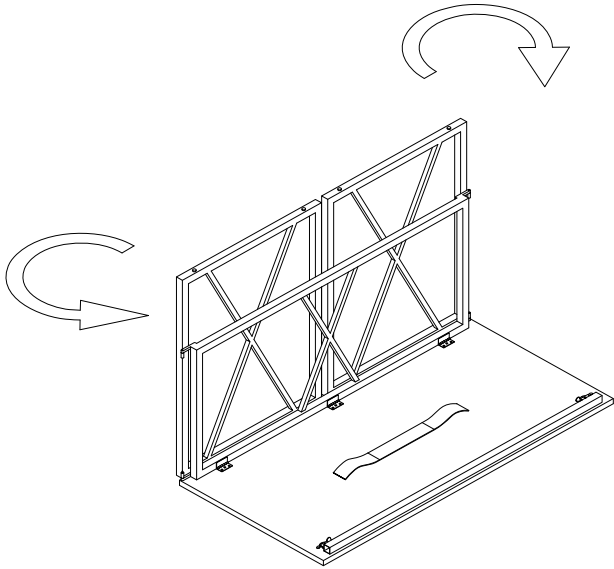

### Step 4

Push the front upper corner of side frame onto front metal tube and align to lock with the side frame hole.

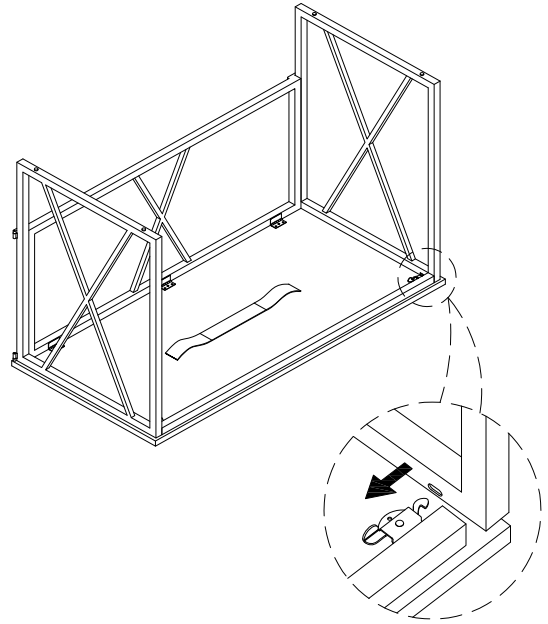

### Step 5

Flip the whole desk and adjust the levelers if needed.

