

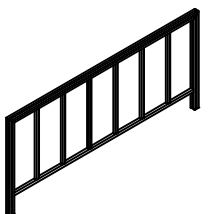





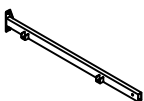
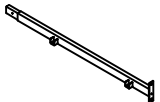
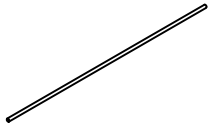
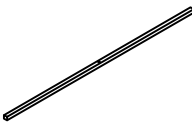
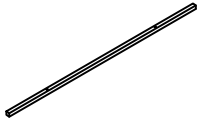

ASSEMBLY INSTRUCTION

QUEEN BED

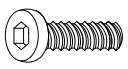
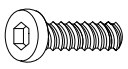
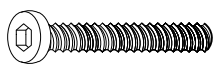
A Headboard  1pc	B Footboard  1pc	C Extension Leg  2pcs	D Side Rail  2pcs
E Side Rail  2pcs	F Bar  1pc	G Slat - Front / Rear  2pcs	H Slat - Center  2pcs
I Support Leg  6pcs	J Bolt (Gold Color) $\phi 1/4" \times 5/8"$  4pcs	K Bolt $\phi 1/4" \times 5/8"$  22pcs	L Bolt $\phi 1/4" \times 1-3/4"$  6pcs
M Bolt (Gold Color) $\phi 1/4" \times 2-1/4"$  2pcs	N Flat Washer (Gold Color) $\phi 1/4" \times 16\text{mm}$  6pcs	O Flat Washer $\phi 1/4" \times 16\text{mm}$  28pcs	P Allen Key M4  1pc

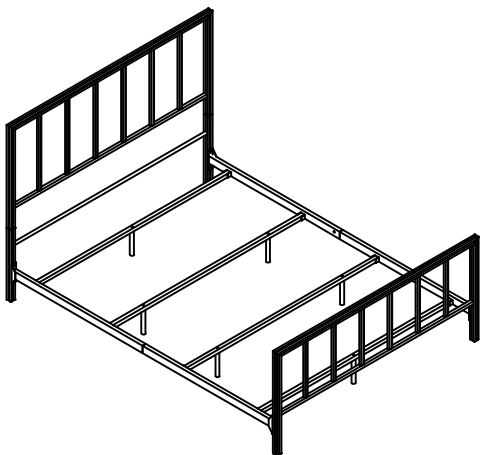

This page lists all the contents included in the box. Please take the time to identify the hardware as well as the individual components to this product. As you unpack and prepare for assembly, place the contents on a carpeted or padded area to protect them from damage.

1 Assemble Bar (F) to the Extension Leg (C) with Bolt (M), Flat Washer (N) then fastened using Allen Key (P).

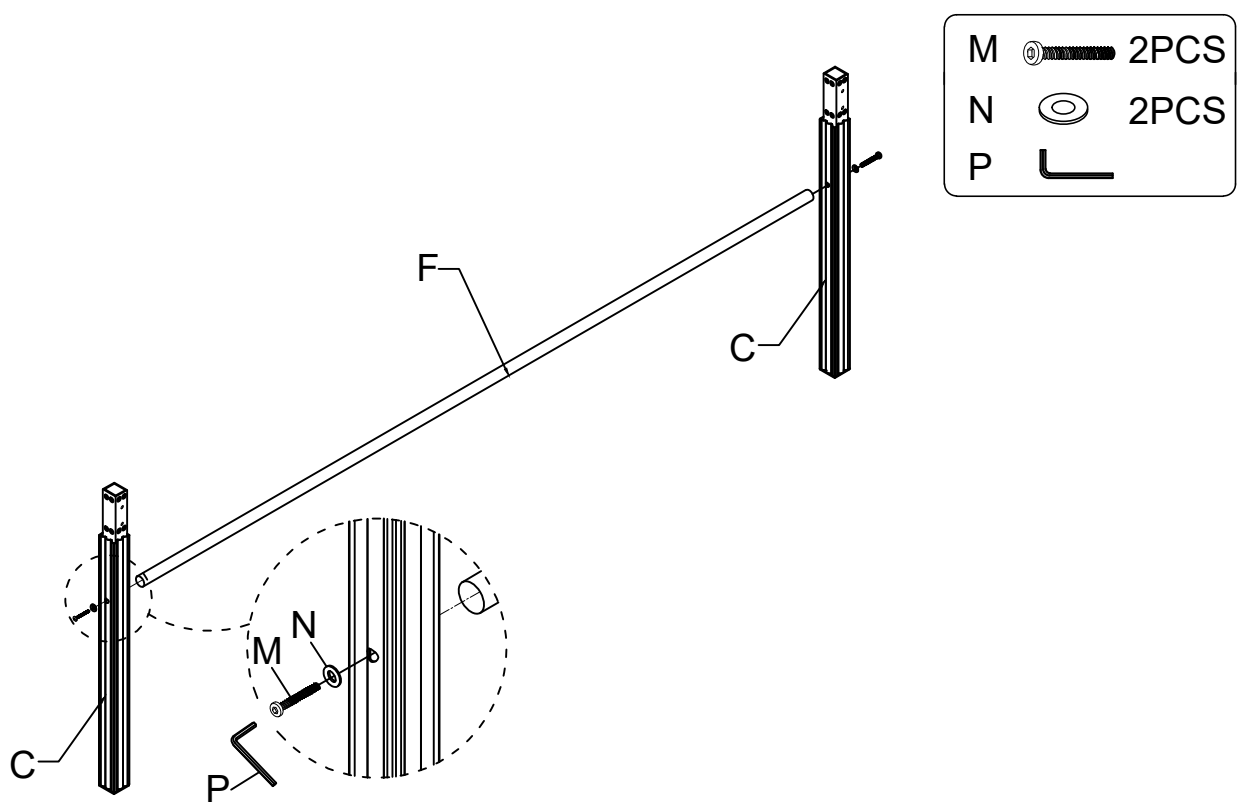

2 Assemble the Headboard (A) to the Extension Leg (C) with Bolt (J), Flat Washer (N) then fastened using Allen Key (P).

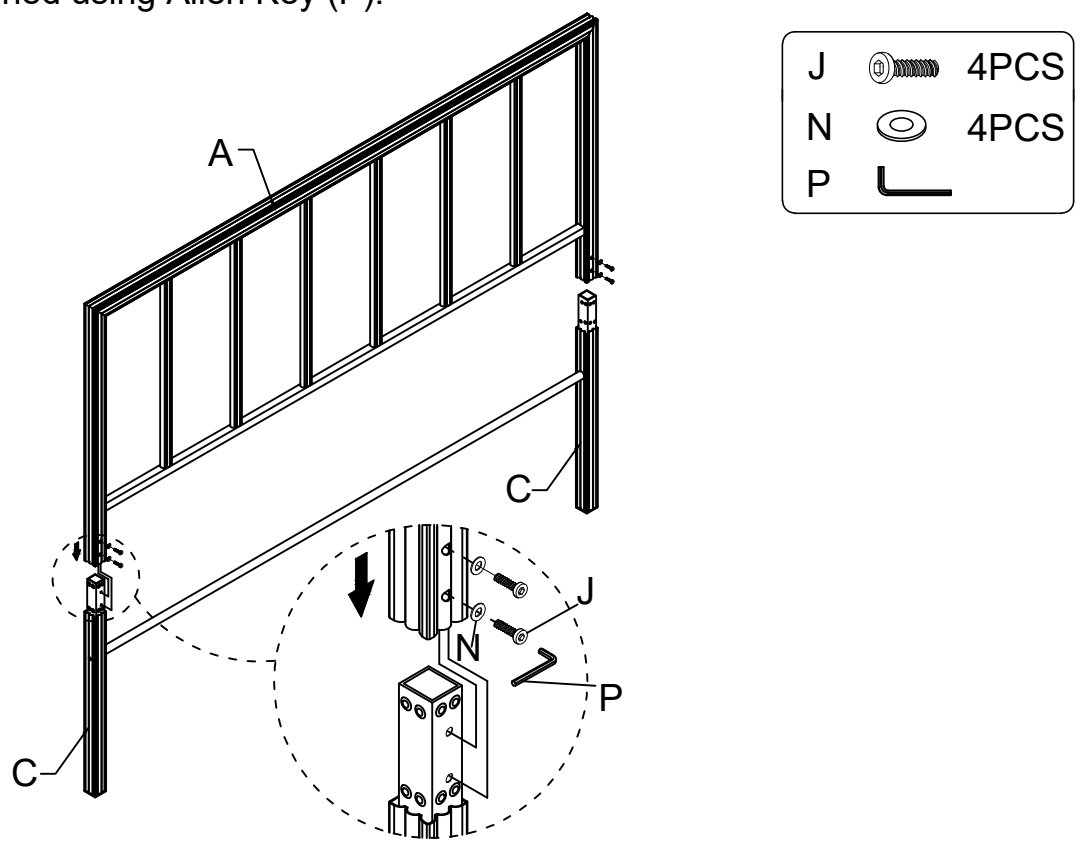

3 Connect both Side Rail (D) & Side Rail (E) using Bolt (K), Flat Washer (O) by Allen Key (P) as picture shown.

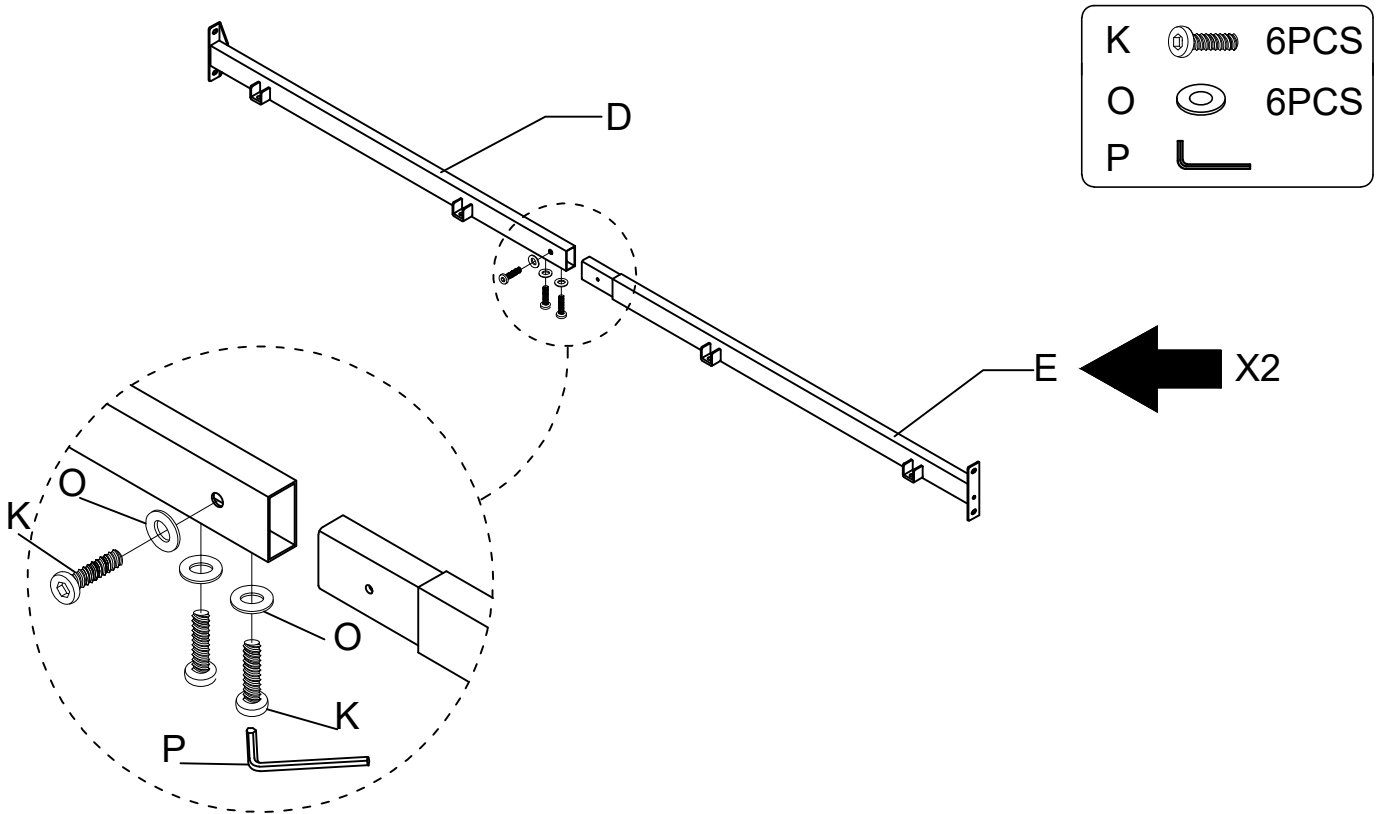

4 Attach the Side Rail (D) & Side Rail (E) to Extension Leg (C) and Footboard (B) using Bolt (K), Flat Washer (O) by Allen Key (P).

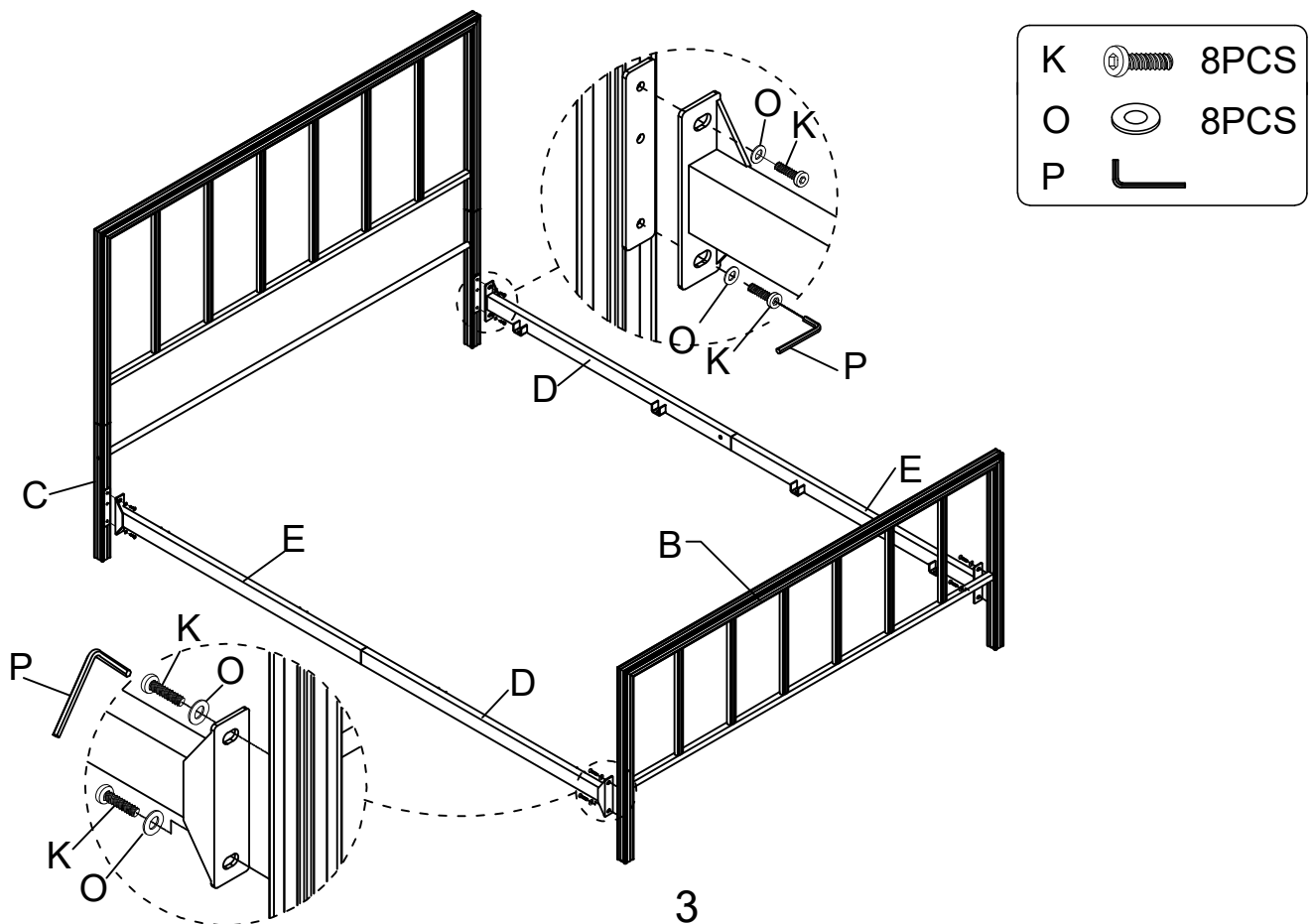

5 Attach the Support Leg (I) to Slat - Front / Rear (G) and Slat - Center (H) using Bolt (L), Flat Washer (O) by Allen Key (P) as picture shown.

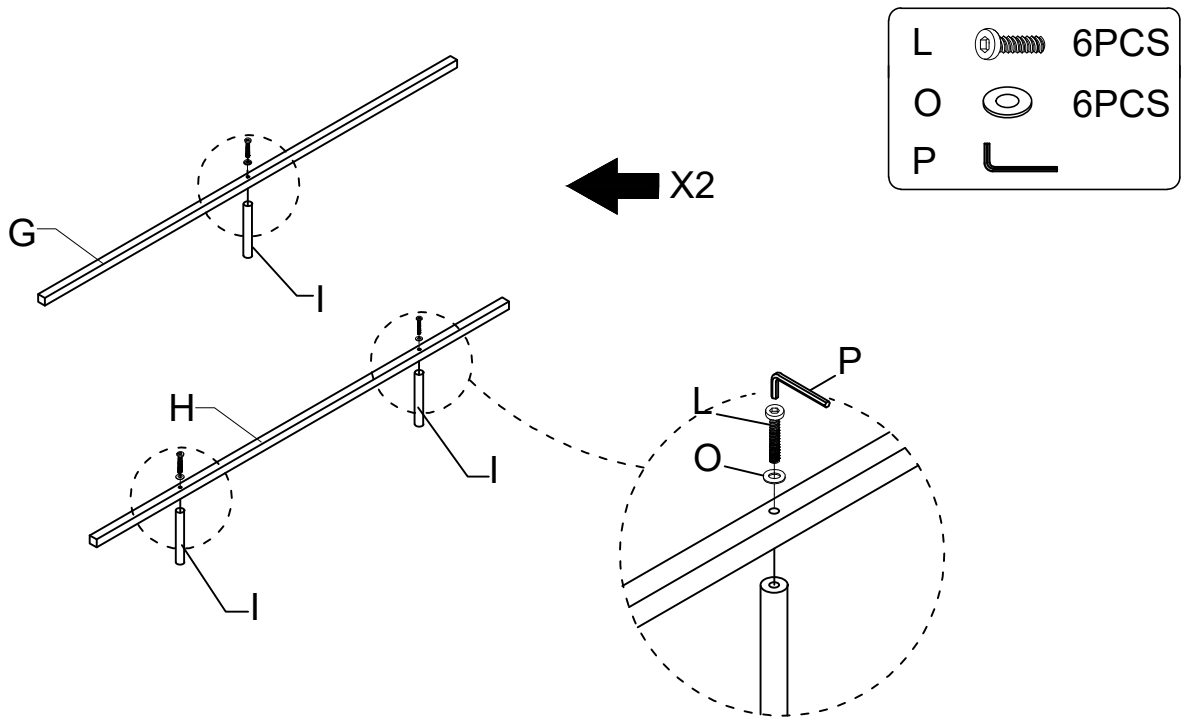

6 Attach the pre-assembled Slat - Front / Rear (G) and Slat - Center (H), Side Rail (D) & Side Rail (E) using Bolt (K), Flat Washer (O) by Allen Key (P) as picture shown.

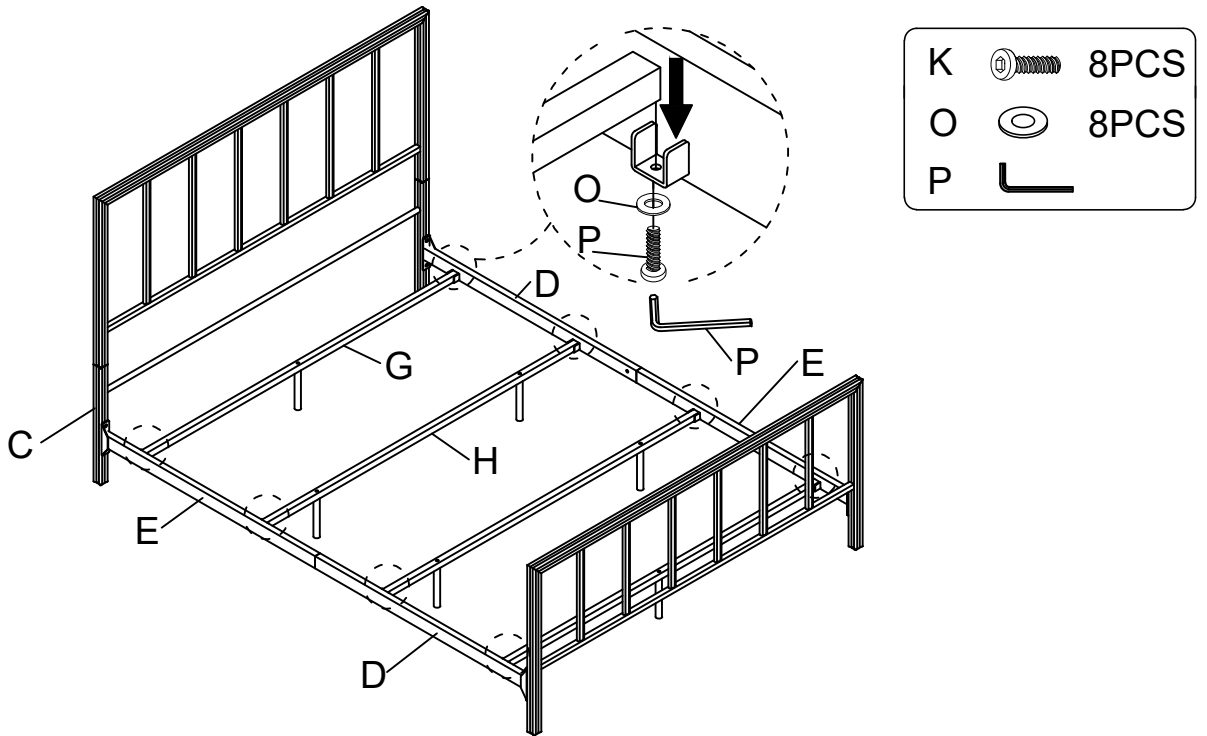

Adjust any parts out of alignment and tighten all bolts and screws from steps 1 through 6.

Cleaning & Care

Treat surface with care. Surface is resistant to scratches but is not scratch resistant. Clean surfaces with a dry or damp soft cloth. Do not use abrasive cleaners. Hardware may loosen over time. Periodically check that all connections are tight.