



Project:

Item Number:

Quantity:

**U412 & SU412 SINGLE FLAVOR, PRESSURIZED SHAKE FREEZER WITH REFRIGERATED CABINET**



**DESCRIPTION**

Single flavor, pressurized shake freezer with refrigerated cabinet provides greater reliability and quieter operation with Stoelting's high-efficiency evaporator and Scroll Compressor. Proprietary auger design gently folds mix and prevents product breakdown. Refrigerated mix storage cabinet has a slide-out mix shelf and a non-contact mix-pump system. Built for consistent control of all mixes.

**ITEMS**

- U412-38I** Air cooled, single phase
- SU412-38I** Air cooled, single phase, with Spinner
- SU412-38I** Water cooled, single phase, with Spinner

**ACCESSORIES & OPTIONS**

- Front Door Mounted Spinner (S Prefix)** Dispensing and mixing product is accomplished with a single front-mounted handle for fastest speed of service.

**FEATURES**

- NSF approved food grade plastic blades provide quiet operation and superior durability.
- Adjustable speed on the mixer.
- Simplified design for quick assembly after cleaning.
- Clear door displays circulating product for merchandising appeal.
- Highly efficient auger design gently folds the entire contents of the freezing cylinder, delivering a thick, smooth, and creamy product.
- Pump approved for clean-in-place, reducing cleaning time and labor requirements.
- Mix containers in the refrigerated storage cabinet safely hold up to 8 gallons of mix, providing enough product during peak times and reducing the frequent refills.
- Tamper-proof controls for self-serve applications.
- Reliable and quiet with the combination of Stoelting's evaporator system and the Scroll™ compressor.
- Mix pumps inject the exact amount of air into your mix, maintaining overrun to ensure maximum profitability.

 Every machine includes Stoelting's White Glove Service. One call does it all – customer service, technical service, parts or warranty information, installation, startup, sales, on-site service dispatch and much more. Available 24 hours a day, seven days a week year-round.

*Continuous research leads to ongoing product improvements; therefore, these specifications are subject to change without notice and should not be used as installation specifications.*

Approvals	Date

**U412 & SU412 SINGLE FLAVOR, PRESSURIZED SHAKE FREEZER WITH REFRIGERATED CABINET**

**DIMENSIONS**

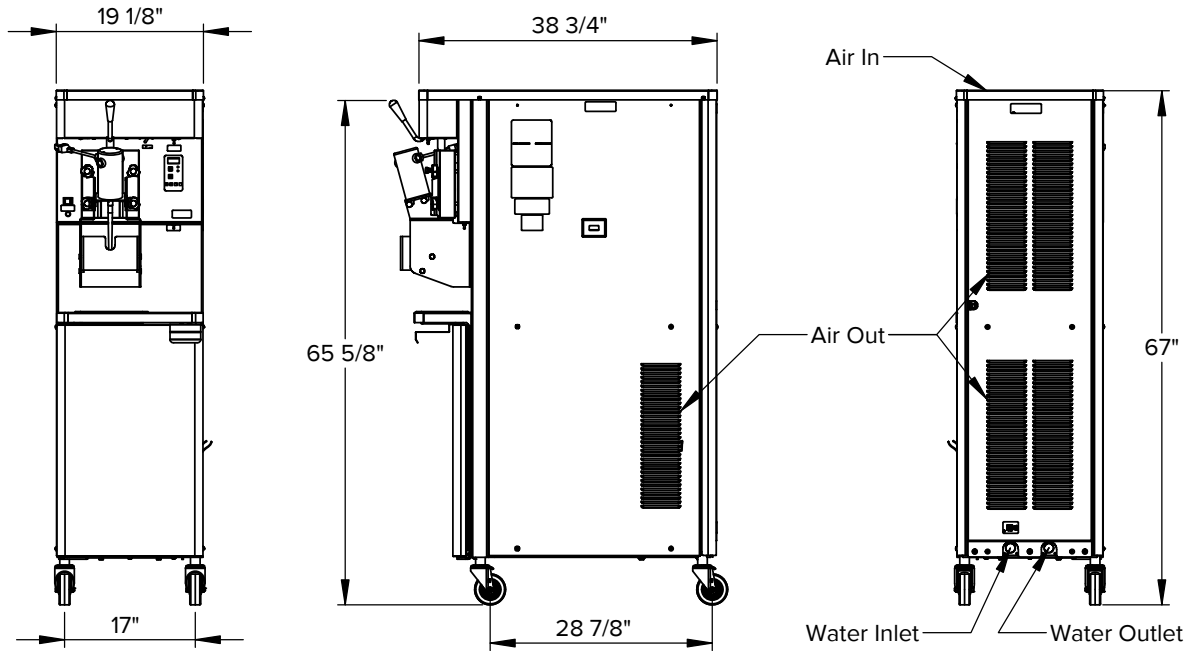

Height dimensions may vary ±1" due to casters

**GENERAL SPECIFICATIONS**

Freezing Cylinder				Cabinet Capacity gallon (L)	Drive Motor (hp)	Weight lb (kg)	Crated Weight lb (kg)
Capacity gallon (L)	Compressor						
	Btu/hr	Refrigerant	Charge (oz)				
2.1 (7.95)	11,000	R-448A	A/C: 34 W/C: 26	8 (30.3)	3/4	450 (204.1)	550 (249.5)

- Indoor use only.
- Maximum ambient temperature: 100°F (37.8°C).
- Requires a dedicated electrical circuit.
- Electrical plug not included. Hardwired connection required.
- Air cooled units require: 3" (7.6 cm) air space on both sides and 6" at the back.
- Water cooled units require: 1/2" N.P.T. water and drain fittings. Maximum water pressure of 130 psi. Minimum water flow rate of 3 GPM. Ideal EWT of 50°-70°F.
- Details on CAD Revit Symbols Libraries are available on [stoelting.klccad.com](http://stoelting.klccad.com)

**ITEM NUMBER SPECIFICATIONS**

Model Number	Cooling	Phase	Volts	Hz	Maximum Overcurrent Protection Device (Amps)	Minimum Circuit Ampacity (Amps)	Front Door Mounted Spinner
SU412-18l	Water	1	208-240	60	30	18	✓
SU412-38l	Air	1	208-240	60	30	19	✓
U412-38l	Air	1	208-240	60	30	18	—



**Service Information**  
 800-319-9549 (U.S. Toll Free)  
 920-894-2293 (Outside the U.S.)  
[www.stoeltingfoodservice.com](http://www.stoeltingfoodservice.com)  
[www.vollrath.com](http://www.vollrath.com)