

For Commercial and Industrial Applications

Job Name _____

Contractor _____

Job Location _____

Approval _____

Engineer _____

Contractor's P.O. No. _____

Approval _____

Representative _____

LEAD FREE*

Series S-FBV-1 2-Piece, Full Port, Stainless Steel Ball Valves

Sizes: 1/4" – 3"

Series S-FBV-1 2-Piece, Full Port, Stainless Steel Ball Valves are suitable for a full range of liquids and gases. The S-FBV-1's full port orifice ensures maximum flow capacity, while reinforced PTFE seats, PTFE stem packing, thrust washer and body seal provide maximum safety and high operating pressure/temperature limits.

Features

- Pressure rated at 1000psi (69 bar) WOG non-shock and 125psi (8.6 bar) WSP
- Adjustable stem packing
- Bottom loaded, blowout proof stem
- Drilled and tapped mounting pads
- Standard Latch-Lok handle to lock in open or close position
- PTFE stem packing, thrust washer and body seal
- Reinforced PTFE seat
- Vinyl insulator on heavy duty 304SS handles
- Low operating torque
- Each valve factory tested
- Conforms to MSS-SP-110 and API-598

Specifications

A 2-piece full port stainless steel ball valve to be installed as indicated on the plans. The valve must have an adjustable stem packing, reinforced PTFE seats, PTFE stem packing, thrust washer and body seal. Pressure rating no less than 1000psi (69 bar) WOG non-shock, 125psi (8.6 bar) WSP. Valve must conform to MSS-SP-110. Valve shall be a Watts Series S-FBV-1.



Pressure – Temperature

Temperature Range: 0°F - 400°F (-18°C – 204°C)

Maximum Working Pressure: 1000psi (69 bar) WOG non-shock; 125psi (8.6 bar) WSP

Approvals

1/4" - 2"



NOTICE

The information contained herein is not intended to replace the full product installation and safety information available or the experience of a trained product installer. You are required to thoroughly read all installation instructions and product safety information before beginning the installation of this product.

NOTICE

Inquire with governing authorities for local installation requirements

*The wetted surface of this product contacted by consumable water contains less than 0.25% of lead by weight.

Materials

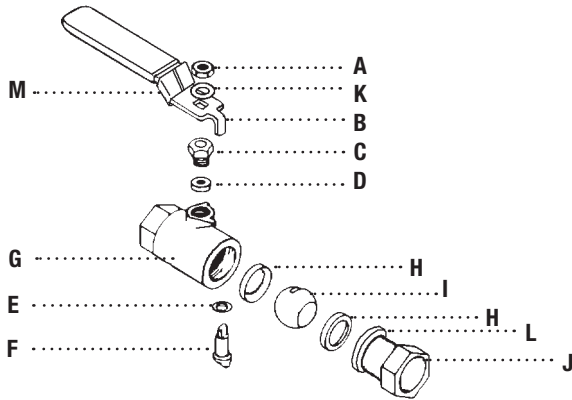

- A Handle Nut: AISI 304
- B Handle: AISI 304 with Vinyl Insulator
- C Packing Nut: AISI 304
- D Stem Packing: PTFE
- E Thrust Washer: PTFE
- F Stem: AISI 316
- G Body: ASTM A351 gr.CF8M
- H Seats: Reinforced PTFE
- I Ball: ASTM A351 gr.CF8M
- J Adapter: ASTM A351 gr.CFM
- K Lock Washer: AISI 304
- L Body Seals: PTFE
- M Latch-Lok: AISI 304

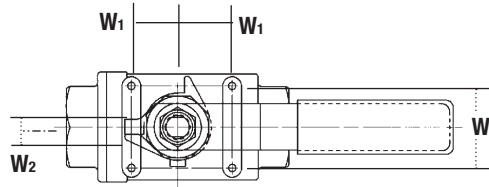

Valve Seat Rating

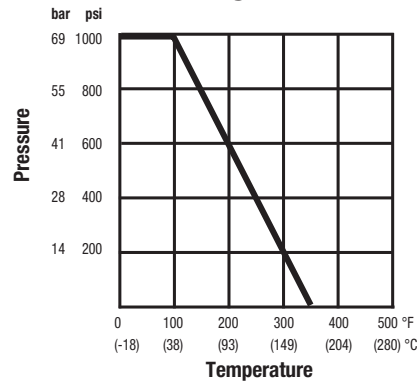

SIZE	CV	TORQUE	
<i>in.</i>	<i>Rating</i>	<i>in. - lbs.</i>	<i>N - m</i>
1/4	6	36	4.07
3/8	12	36	4.07
1/2	19	43	4.86
3/4	37	65	7.34
1	64	102	11.53
1 1/4	103	160	18.08
1 1/2	143	188	21.24
2	360	340	25.99
2 1/2	440	430	48.59
3	520	780	88.06

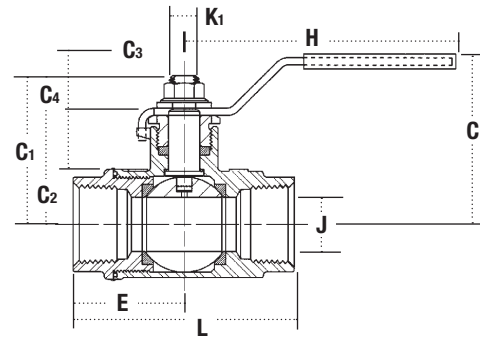

Dimensions – Weights

SIZE	DIMENSIONS													
	C		C1		C2		C3		C4		E		H	
<i>in.</i>	Center to Handle <i>in.</i>	<i>mm</i>	Stem Top <i>in.</i>	<i>mm</i>	Bottom of Stem Flat <i>in.</i>	<i>mm</i>	Mounting Pad to Stem Top <i>in.</i>	<i>mm</i>	Stem Flat Height <i>in.</i>	<i>mm</i>	Center to End <i>in.</i>	<i>mm</i>	Radius to Handle <i>in.</i>	<i>mm</i>
1/4	1 3/4	44	1 9/16	40	1	25	7/8	22	9/16	14	1 1/16	27	3 15/16	100
3/8	1 3/4	44	1 9/16	40	1	25	7/8	22	9/16	14	1 1/16	27	3 15/16	100
1/2	2	51	1 3/4	44	1 3/16	30	1 1/8	29	9/16	14	1 1/16	30	4 1/2	114
3/4	2	51	2	51	1 3/8	35	1 1/8	29	9/16	14	1 1/16	33	4 1/2	114
1	2 1/2	64	2 1/4	57	1 11/16	43	1 5/16	33	5/8	16	1 5/8	41	4 5/16	125
1 1/4	2 3/4	70	2 1/2	64	1 7/8	48	1 5/16	33	5/8	16	1 3/4	44	4 5/16	125
1 1/2	3 5/16	84	3	76	2 1/8	54	1 9/16	40	7/8	22	2 1/4	57	6 5/16	160
2	3 3/8	92	3 1/4	83	2 1/2	64	1 5/8	41	3/4	19	2 1/2	64	6 5/16	160
2 1/2	4 1/2	114	4 1/2	114	3 3/16	84	2 1/8	54	1 1/4	32	3 1/4	83	9 1/16	230
3	5	125	4 5/16	125	3 3/4	95	2 1/8	54	1 3/16	30	3 1/2	89	9 1/16	230

SIZE	DIMENSIONS										WEIGHT			
	J		K1		L		W		W1		W2		<i>lbs.</i>	<i>kg</i>
<i>in.</i>	Ball Orifice <i>in.</i>	<i>mm</i>	Stem Diameter <i>in.</i>	<i>mm</i>	End to End <i>in.</i>	<i>mm</i>	<i>in.</i>	<i>mm</i>	<i>in.</i>	<i>mm</i>	Across Flats <i>in.</i>	<i>mm</i>		
1/4	1/4	6	5/16	8	2 1/16	52	1 1/8	28	1/2	13	3/16	5	.68	.31
3/8	3/8	10	5/16	8	2 1/16	52	1 1/8	28	1/2	13	3/16	5	.68	.31
1/2	1/2	13	3/8	9	2 3/8	60	1 1/8	28	1/2	13	1/4	7	.90	.41
3/4	3/4	19	3/8	9	2 3/8	67	1 3/8	35	7/8	22	1/4	7	1.39	.63
1	1	25	7/16	11	3 1/4	83	1 3/8	35	7/8	22	5/16	8	1.98	.90
1 1/4	1 1/4	32	7/16	11	3 3/8	92	1 1/2	38	1 5/16	24	5/16	8	3.21	1.48
1 1/2	1 1/2	38	5/8	15	4 3/8	111	1 1/2	38	1 5/16	24	3/8	10	4.50	2.04
2	2	51	5/8	15	4 15/16	125	1 1/2	38	1 5/16	24	3/8	10	7.17	3.25
2 1/2	2 1/2	64	3/4	19	6 7/16	164	2 3/16	55	1 3/8	35	1/2	13	15.4	7.0
3	3	76	3/4	19	7 1/2	191	2 3/16	55	1 3/8	35	1/2	13	21.17	9.6



USA: T: (978) 689-6066 • F: (978) 975-8350 • Watts.com
 Canada: T: (905) 332-4090 • F: (905) 332-7068 • Watts.com
 Latin America: T: (52) 81-1001-8600 • Watts.com