

# INSTRUCTION MANUAL

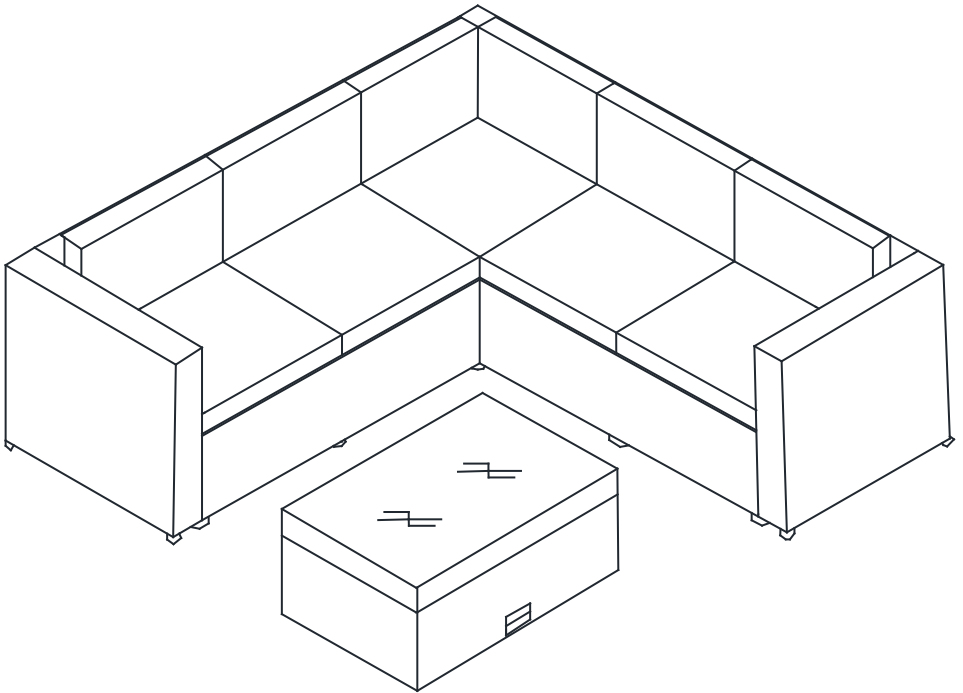

**6-Seating Modern Sectional Set  
with Storage Ottoman  
SKU: P152**

## ! NOTICE

### Do not overtighten screws. (Insert all screws before tighten screws.)

- Please do not exceed the weight limitations of this item.
- Do not stand on or use any part of this item as a step ladder.
- Firmly secure all bolts, screws and nuts before use.
- Reconfirm that all bolts, screws, and nuts are secure every 90 days.
- Do not use or store this item in the proximity of open flame or flammable/combustible chemicals.
- Be aware that some parts are heavy and have sharp edges.

## TOOLS REQUIRED



ALLEN WRENCH  
(PROVIDED)



TABLE  
110 LBS  
CAPACITY



LOVESEAT  
660 LBS  
CAPACITY



CHAIR  
330 LBS  
CAPACITY



2 PERSONS  
ASSEMBLY



UP TO 90 MIN.  
ASSEMBLY

## HARDWARE

1

M6 WASHER



53 PCS

2

M6 x 35mm  
BOLT



53 PCS

3

NUT



2 PCS

4

ALLEN  
WRENCH



1 PC

## PARTS

A

CORNER RIGHT SIDE

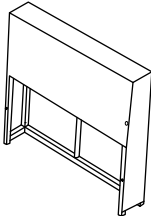

2 PCS

B

CORNER SIDE PANEL

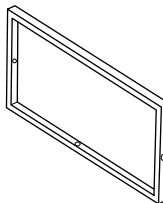

3 PCS

C

CORNER FRONT PANEL

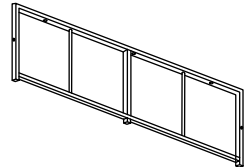

1 PC

**PARTS**

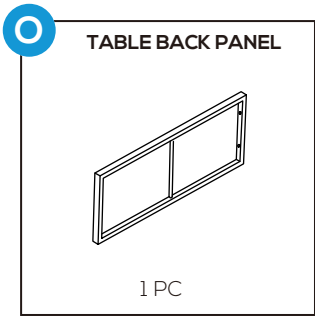
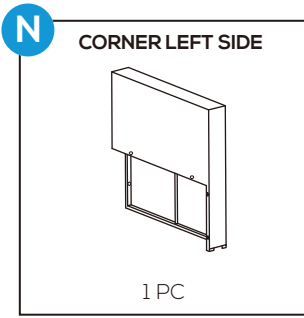
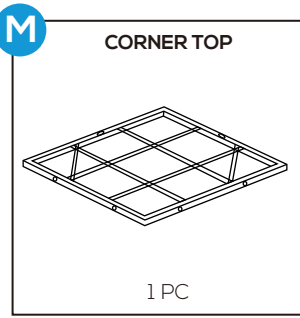
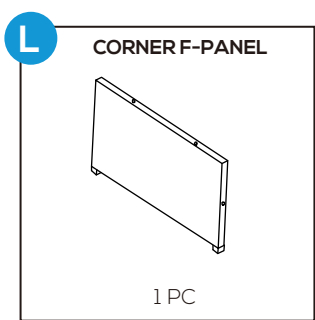
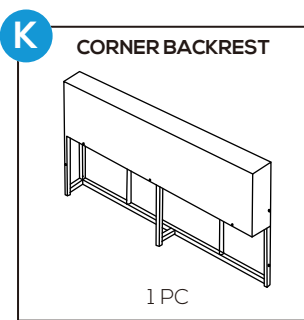
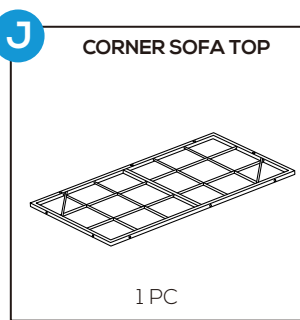
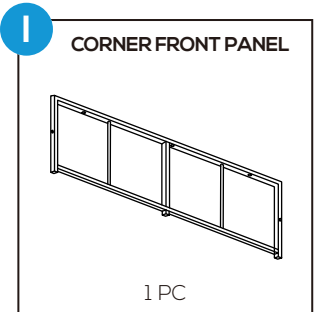
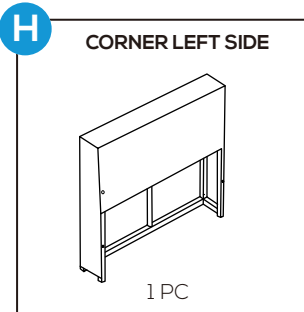
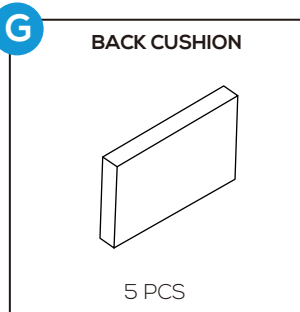
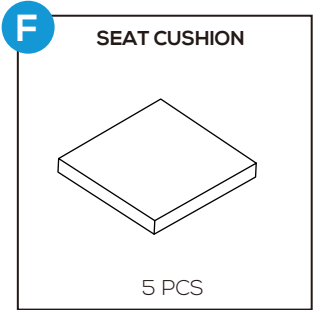
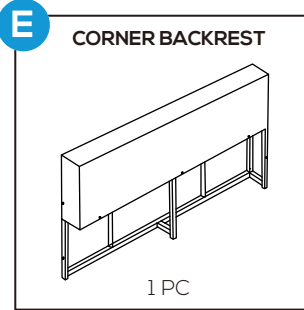
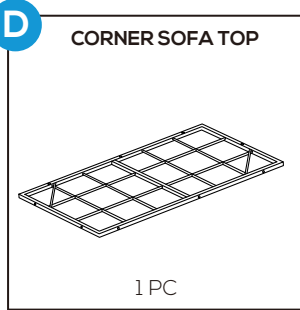

## PARTS

P

TABLE TOP

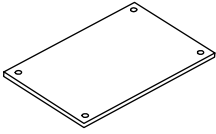

1 PC

Q

TABLE BASE

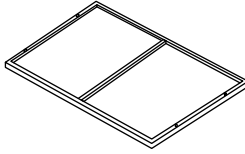

1 PC

R

TABLE FRONT PANEL

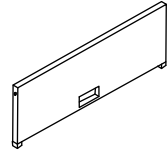

1 PC

S

RIGHT TABLE SIDE

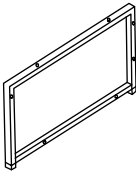

1 PC

T

LEFT TABLE SIDE

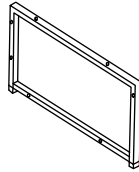

1 PC

U

SIDE CUSHION

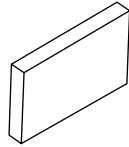

1 PC

V

TABLE COVER

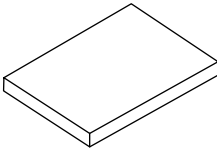

1 PC

W

GLASS TOP

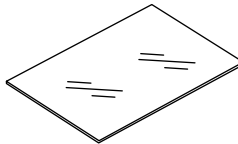

1 PC

## PRODUCT ASSEMBLY - CORNER SEAT

1

Attach part K Corner Backrest to part H Corner Left Side with 2 PCS of part 1 washer and part 2 bolt.

Do not tighten screws too much at this stage.

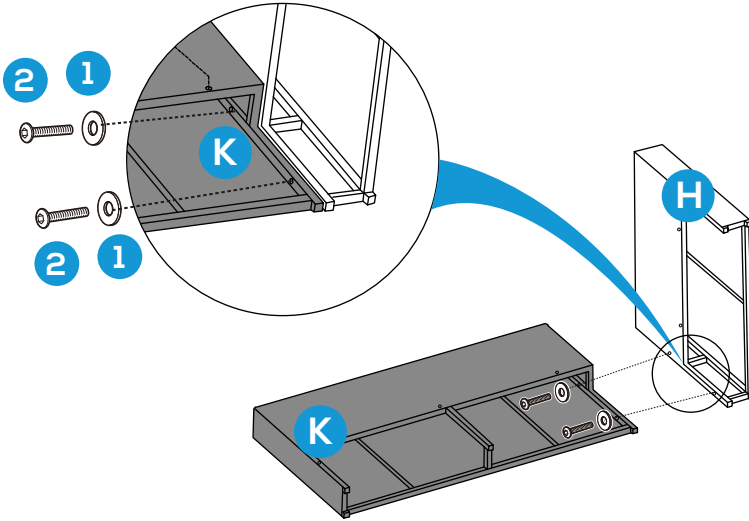

2

Attach part B Corner Side Panel and part I Front Panel to part J Corner Sofa Top with 5 PCS of part 1 washer and part 2 bolt.

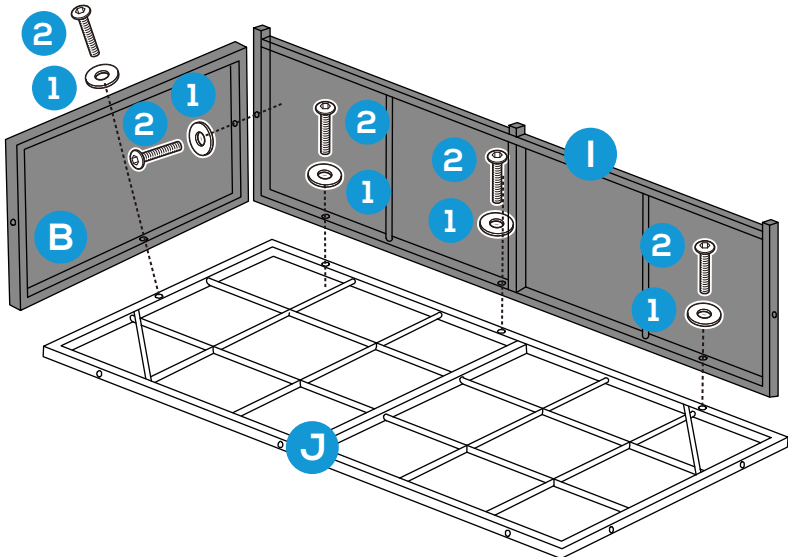

## PRODUCT ASSEMBLY - CORNER SEAT

**3**

Attach the assembled part (B+J) to part H Corner Left Side and part K Corner Backrest with 7 PCS of part 1 washer and part 2 bolt.

Tighten all the bolts again to ensure this corner seat is stable enough to use.

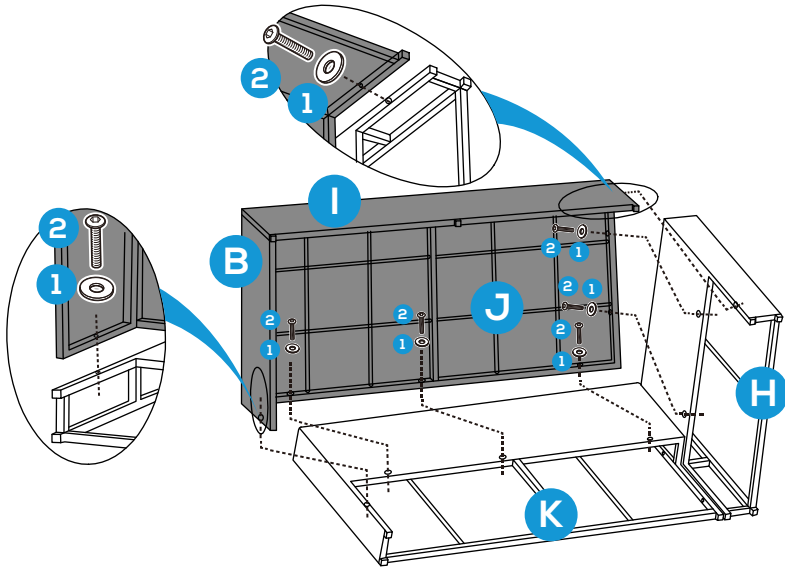

**4**

Place part F Seat Cushion and part G Back Cushions onto the Corner Seat.

The assembly of first corner seat finishes.

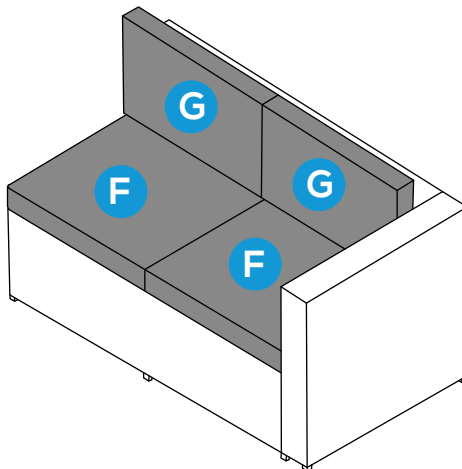

## PRODUCT ASSEMBLY - CORNER SEAT

1

Attach part A Corner Right side to part E Corner Backrest with 2 PCS of part 1 washer and part 2 bolt.

Do not tighten screws too much at this stage.

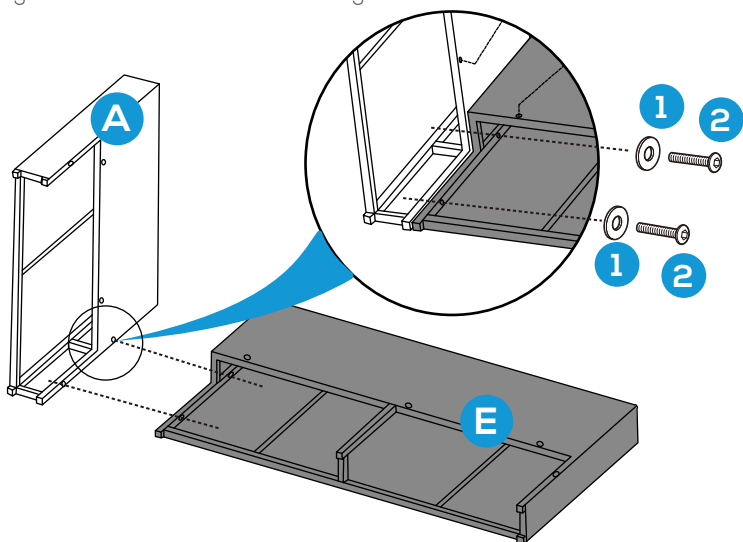

2

Attach part B Corner Side Panel and part C Front Panel to part D Corner Sofa Top as below, with 5 PCS of part 1 washer and part 2 bolt.

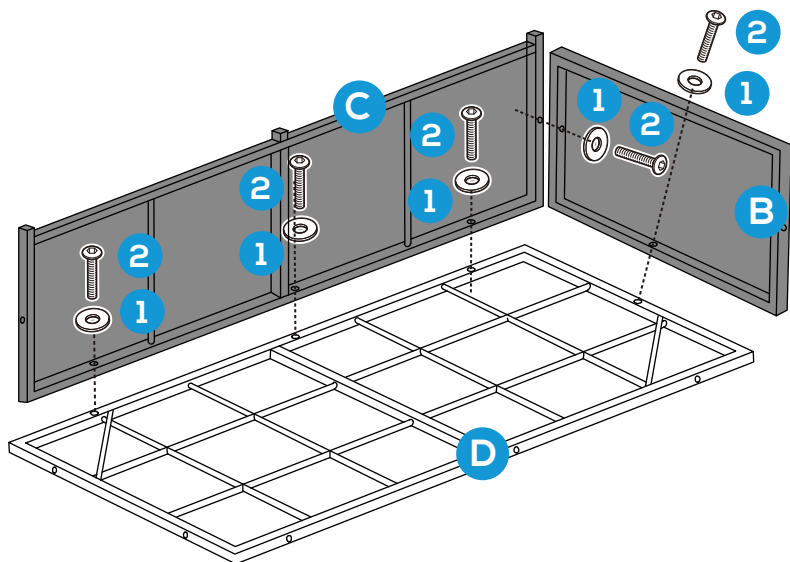

## PRODUCT ASSEMBLY - CORNER SEAT

3

Attach the assembled part (B+C+D) to part A Corner Right Side and part E Corner Backrest with 7 PCS of part 1 washer and part 2 bolt.

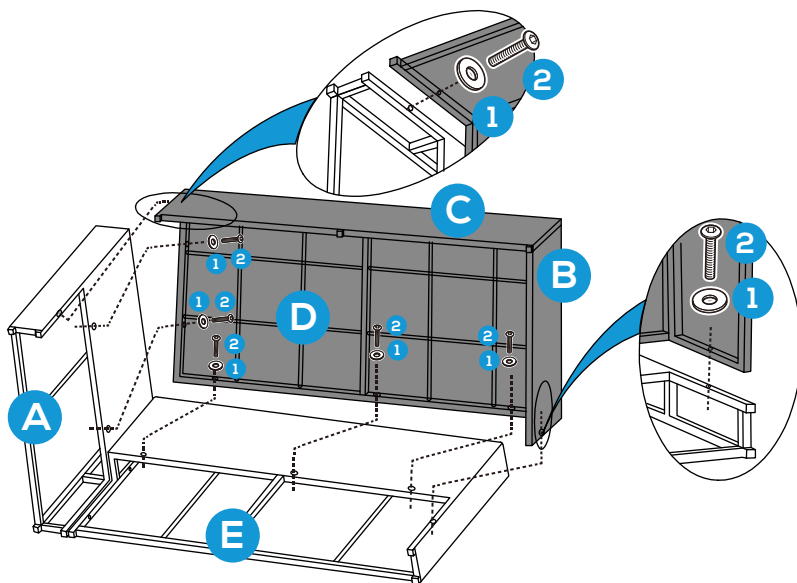

4

Place part F Seat Cushion and part G Back Cushions onto the Corner Seat.

The assembly of second corner seat finishes.

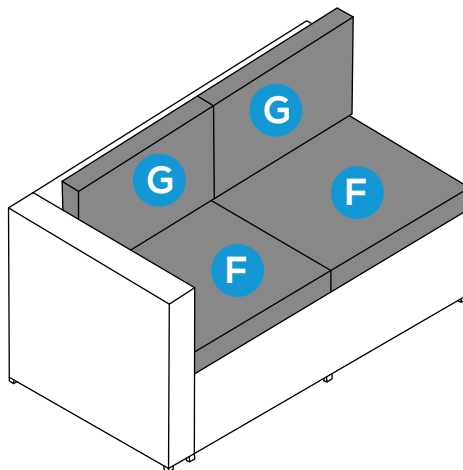



## PRODUCT ASSEMBLY - CORNER SEAT III

1

Attach the part N Corner Left Side to part A Corner Right Side with 2 PCS of part 1 washer and part 2 bolt.

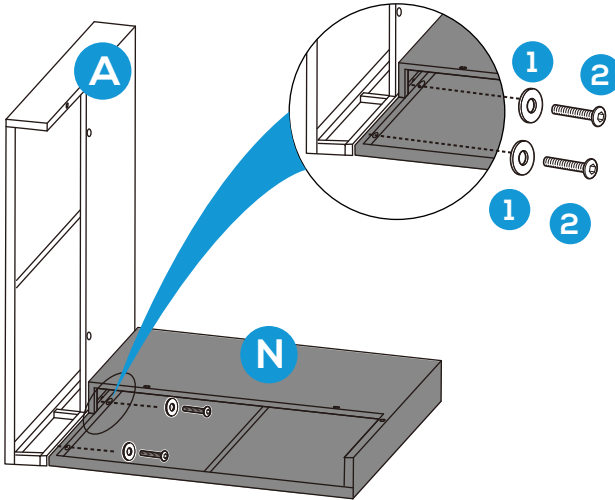

2

Attach the part B Corner Side Panel and part L Corner F-Panel to part M Corner Top with 3 PCS of part 1 washer and part 2 bolt.

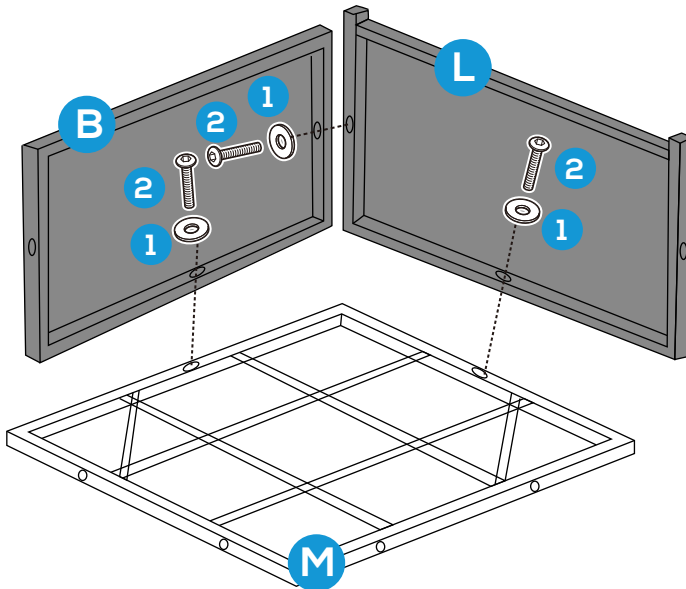

## PRODUCT ASSEMBLY - CORNER SEAT III

3

Attach the assembled part (B+L+M) to part A Corner Right Side and part N Corner Left Side with 6 PCS of part 1 washer and part 2 bolt.

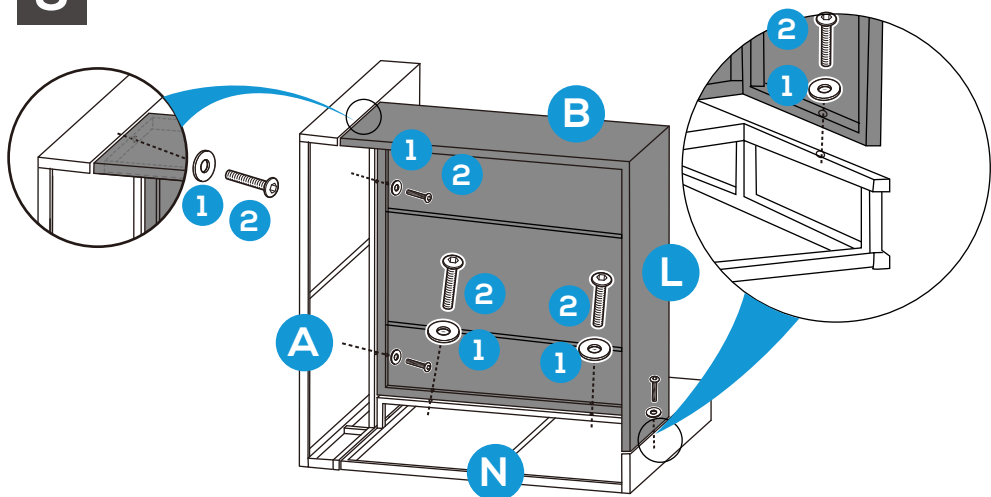

4

Place part F Seat Cushion, part G Back Cushions and part U Side Cushion onto the Corner Seat.

The assembly of single corner seat finishes.

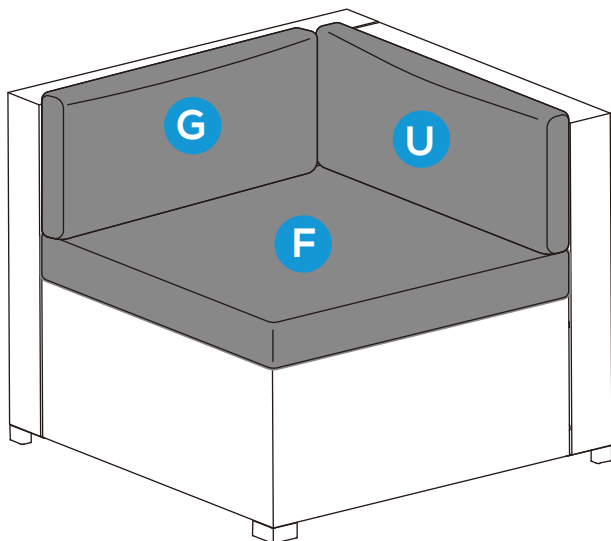

## PRODUCT ASSEMBLY - COFFEE TABLE

1

Attach part S Right Table Side to part P Table Top with 2 PCS of part 1 washer and part 2 bolt.

Do not tighten screws too much at this stage.

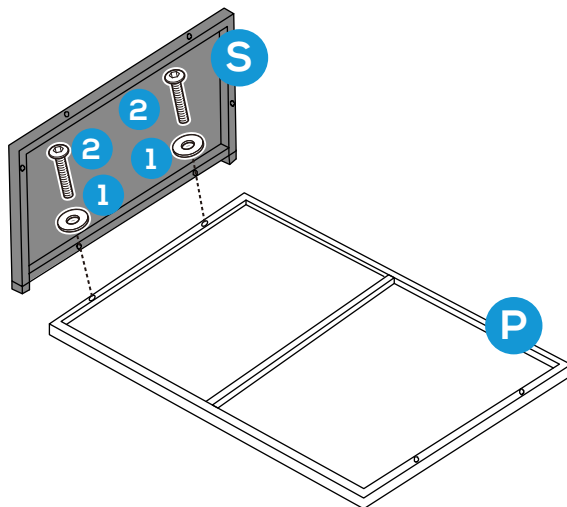

2

Attach part O Table Back Panel to part S Right Table Side and part P Table Top with 2 PCS of part 1 washer and part 2 bolt.

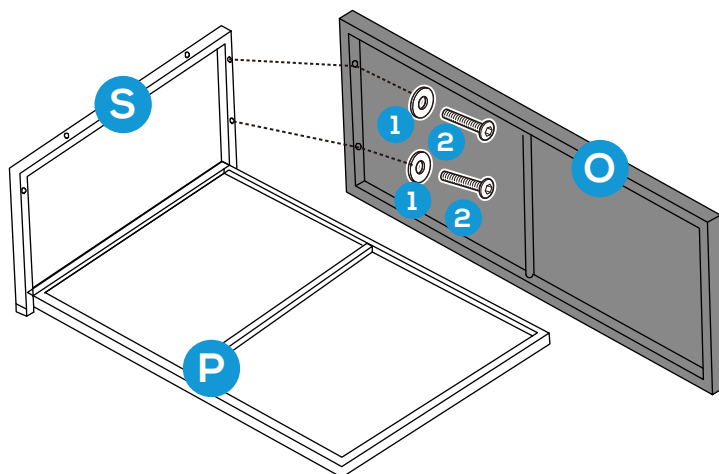

## PRODUCT ASSEMBLY - COFFEE TABLE

3

Attach part T Left Table Side to part P Table Top and part O Table Back Panel with 4 PCS of part 1 washer and part 2 bolt.

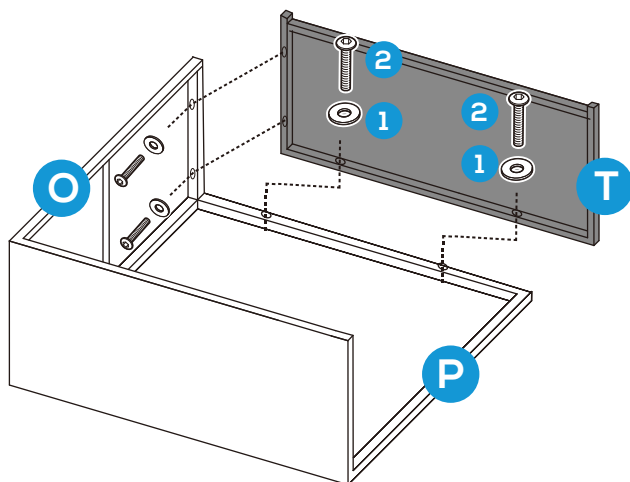

4

Attach part Q Table Base to part S Right Table Side and part T Left table side with 4 PCS of part 1 washer and part 2 bolt.

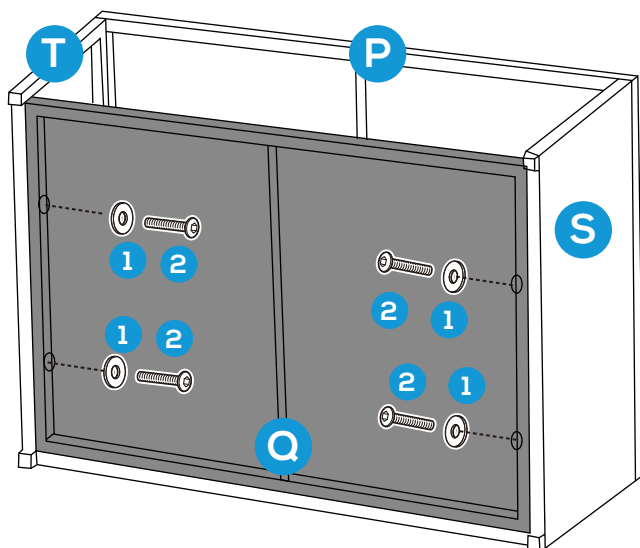

## PRODUCT ASSEMBLY - COFFEE TABLE

5

Attach part R Table Front Panel to part T Left Table Side and part S Right Table Side with 2 PCS of part 1 washer, part 2 bolt and part 3 nut.

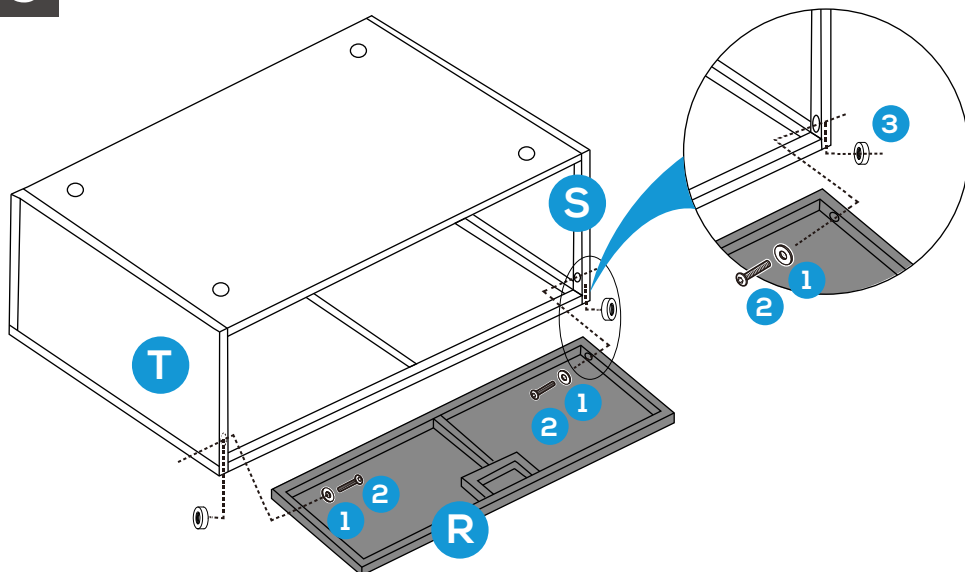

6

Place part W Glass Top or part V Table cover onto part P Table Top.

The Assembly of Coffee Table finishes.

