

Adventure Starts Here.

FOLDING ADIRONDACK CHAIR

**SEAHAWK
DESIGNS**

EST. 2005

! NOTICE

- Do not overtighten hardware.
- Do not exceed the weight capacity of this item.
- Only use this item for what it is intended for, improper use will void any warranty.
- Firmly secure all bolts, screws and nuts before use.
- Reconfirm that all bolts, screws, and nuts are firmly secured every 90 days.
- Keep this furniture clear of all uncontrolled open flames or flammable/combustible materials. Exposure to fire, high heat, or embers will permanently damage the material.
- To avoid stripping and cracking of the material, DO NOT use power tools for assembly.
- Always prioritize caution and safety throughout the assembly process.
- When folding the chair, use caution to keep your hands clear of pinch points.

TOOLS REQUIRED

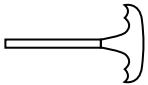

ALLEN WRENCH
(PROVIDED)

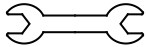

WRENCH
(PROVIDED)



330 LBS
WEIGHT
CAPACITY



SUGGESTED
2 PERSON
ASSEMBLY



ESTIMATED
ASSEMBLY
TIME: 20 MIN

1

SCREW
M6 x 40mm



3 PCS

2

BOLT
M6 x 40mm



4 PCS

3

BOLT
M6 x 45mm



4 PCS

4

BOLT
M6 x 50mm



4 PCS

5

BOLT
M6 x 70mm

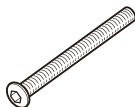

2 PCS

6

M6-NUT



8 PCS

7

M6-WASHER

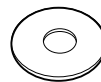

8 PCS

8

SCREW HOLE PLUG



16 PCS

A

CHAIR SEAT

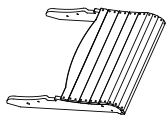

1 PC

B

CHAIR BACKREST

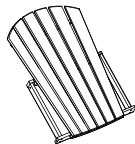

1 PC

C

LEFT FRONT LEG

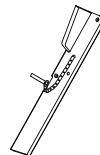

1 PC

D

RIGHT FRONT LEG

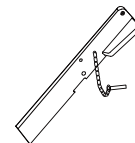

1 PC

E

HINGE BLOCK



2 PCS

F

BACK RAIL



1 PC

G

LEFT ARM

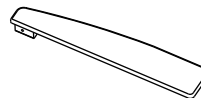

1 PC

H

RIGHT ARM

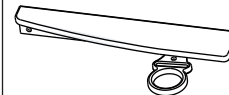

1 PC

I

FRONT RAIL

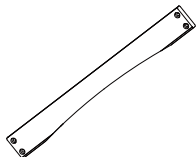

1 PC

J

CUP HOLDER

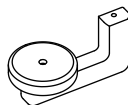

1 PC

PRODUCT ASSEMBLY - OVERALL VIEW

REF#: OP6045

Please refer back to this image during the assembly process for part placement.

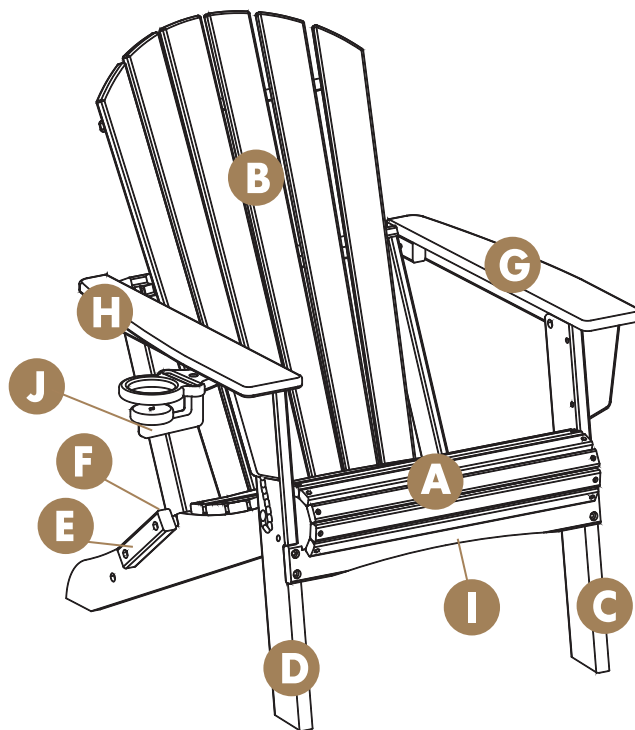

1

Step 1: Assemble the Chair Seat and Legs

- Attach **Part D (Right Leg)** to **Part A (Chair Seat)** using **1 - M6 Bolt (#3)**, **1 - M6 Washer (#7)**, and **1 - M6 Nut (#6)** (see image below).
- Attach **Part C (Left Leg)** to **Part A (Chair Seat)** using **1 - M6 Bolt (#3)**, **1 - M6 Washer (#7)**, and **1 - M6 Nut (#6)** (see image below).
- Do not fully tighten the bolts yet. Tighten them to approximately 70% to allow for adjustments during final assembly.

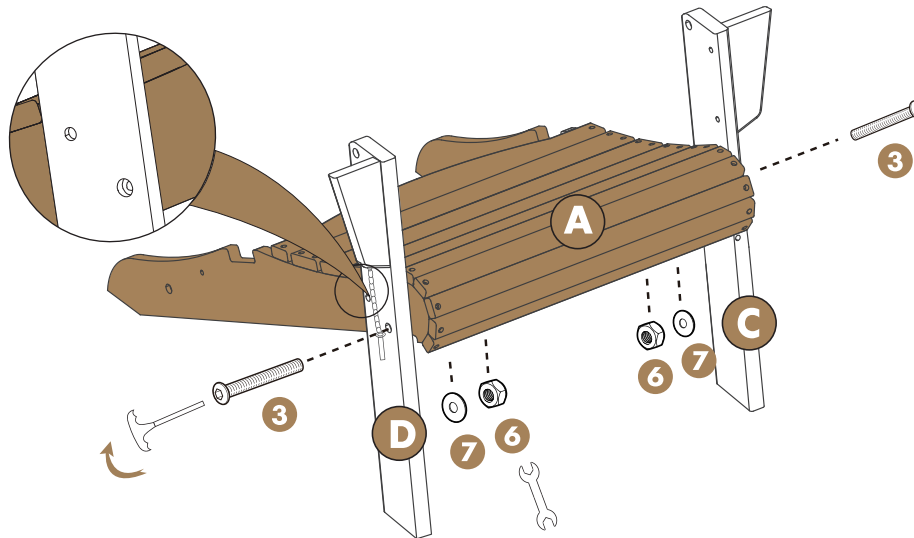

2

Step 2: Assemble the Front Rail

- Attach **Part I (Front Rail)** to **Part A (Chair Seat)** using **4 - M6 Bolt (#2)** (see image below).

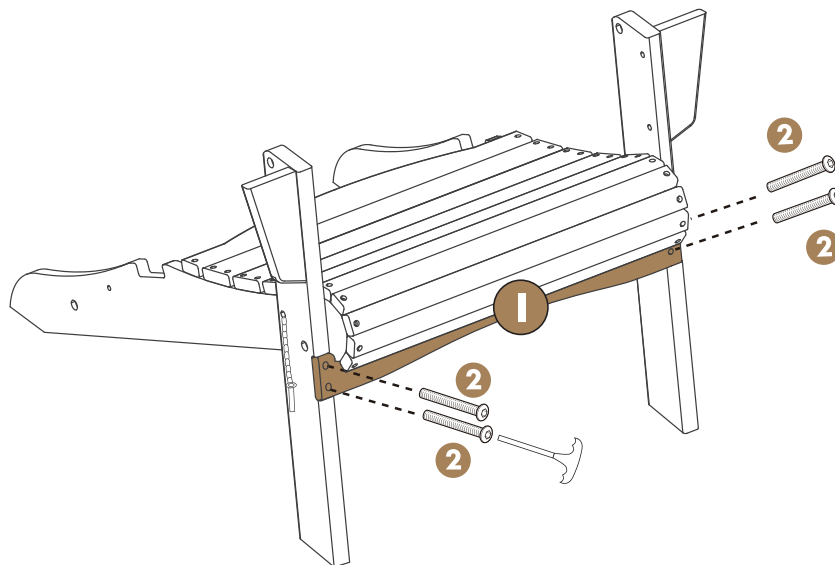

3

Step 3: Insert the Locking Pin to both Legs (see image below).

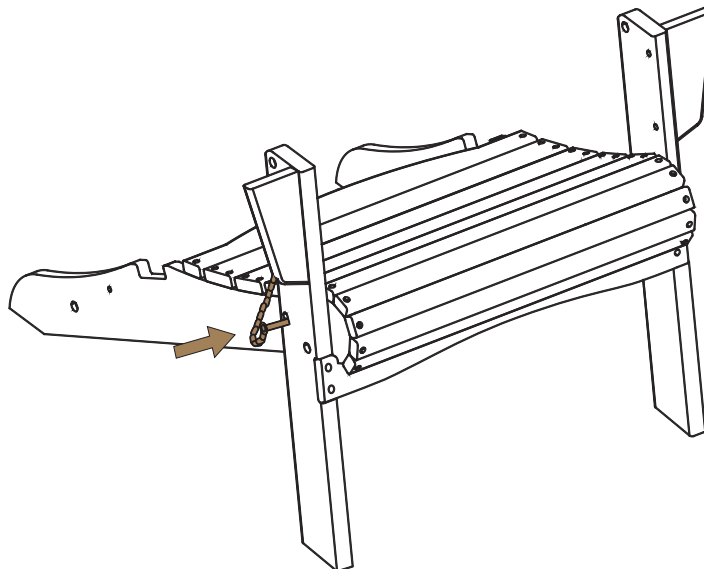

4

Step 4: Attach the Cup Holder to the Arm, and Arm to Chair

- Attach **Part J (Cup Holder)** to the bracket on **Part H (Right Arm)** using **1 - M6 Screw (#1)** (see image below).
- Attach **Part H (Right Arm with Cup Holder)** to **Part D (Right Leg)** using **1 - M6 Bolt (#4)**, **1 - M6 Washer (#7)**, and **1 - M6 Nut (#6)** (see image below).
- Attach **Part G (Left Arm)** to **Part C (Left Leg)** using **1 - M6 Bolt (#4)**, **1 - M6 Washer (#7)**, and **1 - M6 Nut (#6)** (see image below).

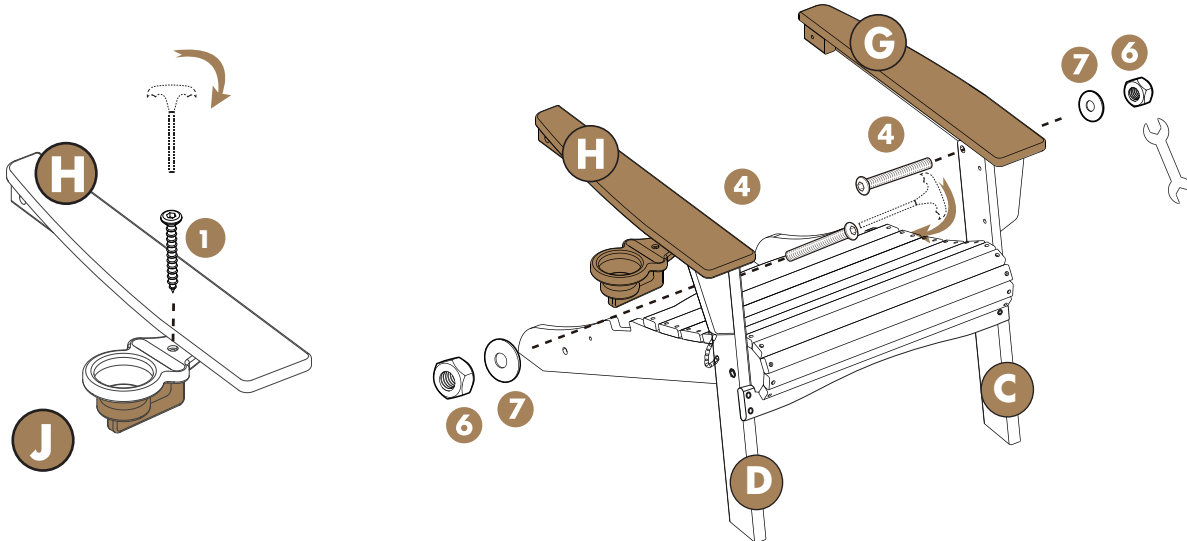

5

Step 5: Attach the Chair Backrest

- Attach **Part B (Chair Backrest)** to **Part H (Right Arm with Cup Holder)** and **Part G (Left Arm)** using **2 - sets of the M6 Bolt (#5), M6 Washer (#7), and M6 Nut (#6)** (see image below).

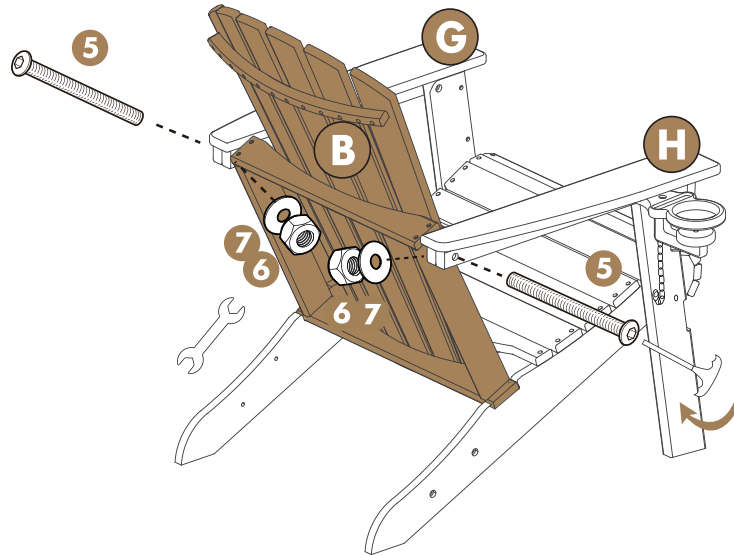

6

Step 6: Attach the Hinge Block

- Attach the **Part E (Hinge Block)** to **Part B (Chair Backrest)** and **Part A (Chair Seat)** using **2 - M6 Bolt (#4)**, and **2 - sets of the M6 Bolt (#3), M6 Washer (#7), and M6 Nut (#6)** (see image below).

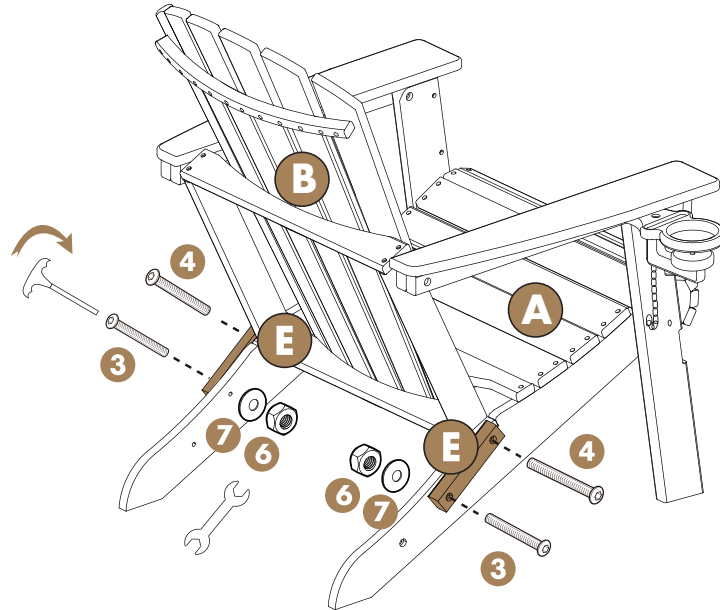

7

Step 7: Assemble the Back Rail

- Attach **Part F (Back Rail)** to **Part A (Chair Seat)** using **2 - M6 Screw (#1)** (see image below).

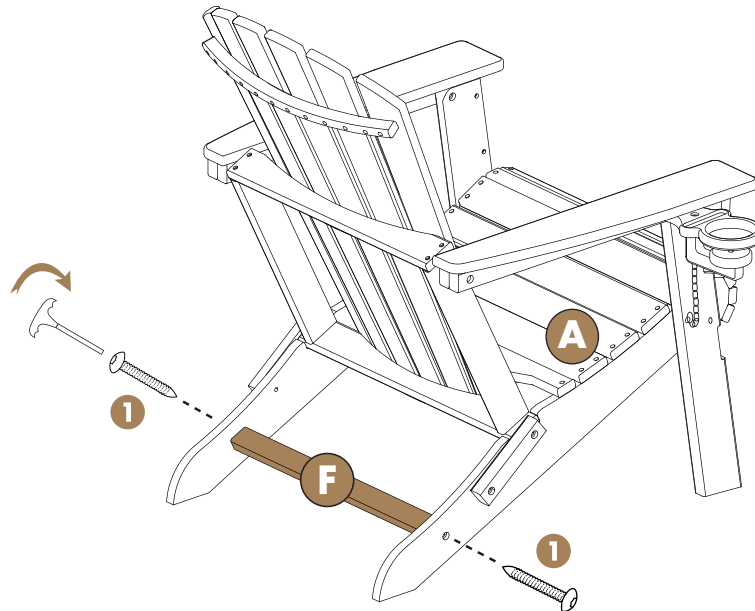

8

Step 8: Final Tightening and Stability Check

- Tighten all previously installed screws, bolts, and nuts. Check every connection to ensure the chair is steady and stable.

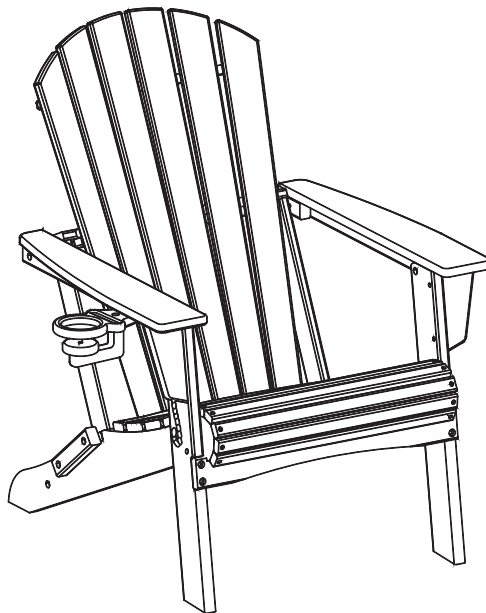

9

Step 9: Apply the Screw Hole Plugs

- Cover all exposed screw holes using **16 - Screw Hole Plug (#8)**. Insert all plugs into the exposed screw holes. Gently tap each plug into place using a rubber mallet to prevent damage. Ensure each plug is fully seated and flush with the chair surface (see image below).

ATTENTION: Do not use a metal hammer as it will damage the poly lumber.

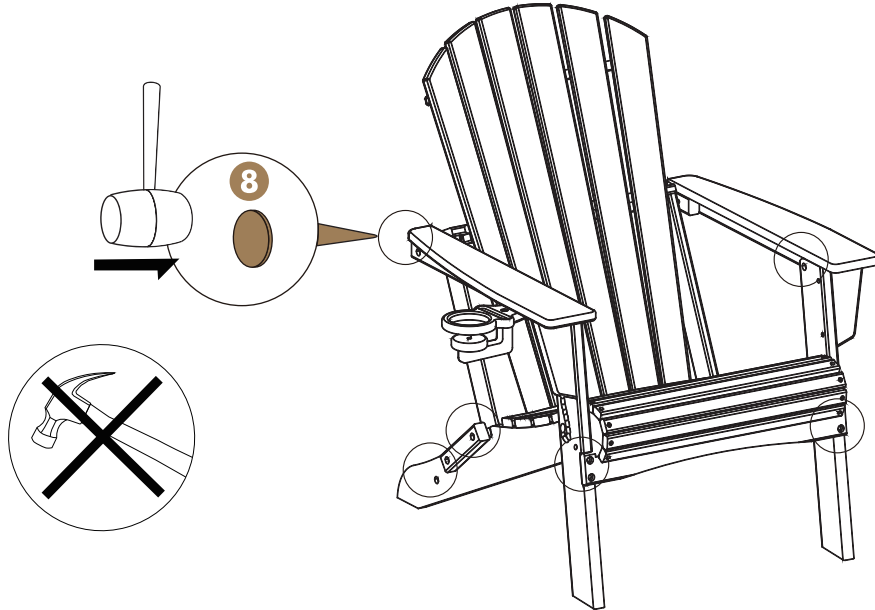

10

Congratulations!

You finished the assembly of this chair.

Pull the locking pin out of both legs to fold this chair as below.

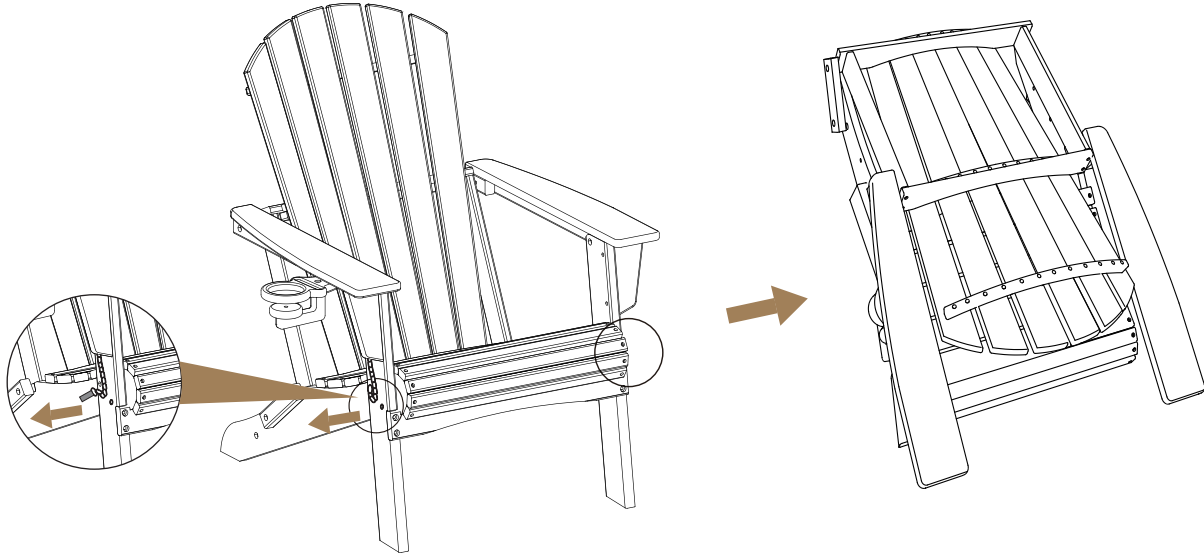

- **REGULAR CLEAN:** Mix **warm water** and **mild soap**. Use a **soft bristle brush** to gently scrub the surface and remove any dirt or stains.
- **QUICK CLEAN:** Simply wipe the furniture down using a damp cloth.

Tip: Cleaning your furniture regularly helps maintain its aesthetic appeal and extends its lifespan.

Enjoy!

Join our community and be the first to see what's new!

Follow us on socials:



Quickly register your outdoor furniture purchase to activate your warranty and enjoy peace of mind with guaranteed product protection:



Have questions or need assistance? Reach out to our dedicated team at **(909) 284-1052** or email us at **cs@seahawkdesigns.com**.