



MAXI-COSI[®]

We carry the future

Coral XP

Infant Car Seat

**KEEP INSTRUCTIONS
FOR FUTURE USE.**

Read all instructions
before using this
infant restraint.



4358-7976A
9.17.20



**⚠ Failure to follow the warnings on the labels
and in the instruction manual can result in
serious injury or death to your infant.**

Overview

Welcome to the Maxi-Cosi family and thank you for choosing this car seat, also known as an infant restraint!

To help you get started using your infant's new car seat, here are the 4 main tasks you'll need to complete:



Measure Your Infant



Adjust Car Seat to Fit Your Infant



Install Car Seat into Your Vehicle



Snugly Secure Your Infant in Car Seat

Your infant's safety is worth the time it will take for you to read and follow these instructions.

Ready? Let's go!

Pages 1-5 will introduce you to the parts of the car seat.

Page 90 has our contact information. If at any point you would like assistance, please feel free to reach out to us.

Quick Navigation

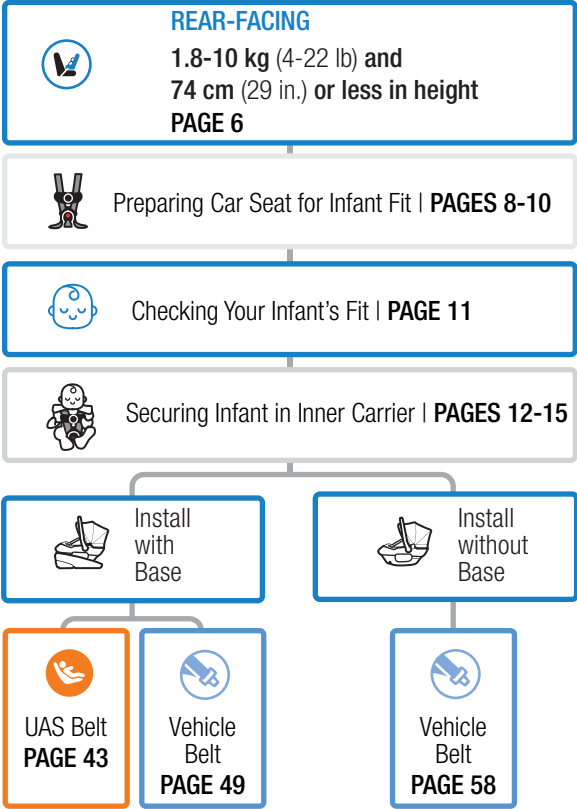

Contents

Getting Started	
Parts of Car Seat	1
Accessory Use	4
Rear-Facing Use Requirements	6
Preparing Car Seat for Infant Fit	8
■ Checking Your Infant's Fit	11
Securing Infant in Inner Carrier	12
Carrier Use	
Changing Harness Strap Position	16
Outer Carrier & Base: Removing & Installing	19
Outer Carrier Use with Inner Carrier	20
Carry Handle Use	20
Inner Carrier & Outer Carrier: Removing & Installing	21
Inner Carrier Use	22
Crossbody Strap Use	22
Base Use	
Adjusting Base	28
Load Leg	29
Release Lever for Vehicle Belt Lockoff & UAS Belt	30
Tightness Indicators	32
Choosing UAS Belt or Vehicle Belt	
■ UAS Belt Use	33
■ Vehicle Belt Use	35

Rear-Facing Use With Base	41
UAS Belt Install With Base	43
Vehicle Belt Install with Base	49
Installing Outer Carrier to Installed Base	55
Rear-Facing Use Without Base	57
Vehicle Belt Install without Base	58
Wash & Care of Car Seat Parts	
Removing Harness System	63
Removing Seat Pad	65
Removing & Installing Canopy	68
Cleaning Parts of Car Seat	69
Installing Seat Pad	70
Installing Harness System	73
Safety Information	
Aircraft Information	76
Replacement and Expiration of Car Seat	77
Infant Restraint Use	79
Installation in Vehicle	80
Vehicle Seating Position	80
Transport Canada Regulations	82
Registration and Safety Notices	83
Additional Information	
Warranty	85
Replacement Parts List	88
Dorel Juvenile Group Information	89

Parts of Car Seat

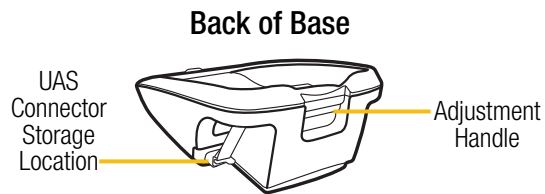
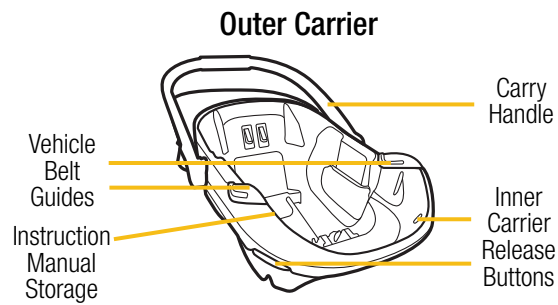
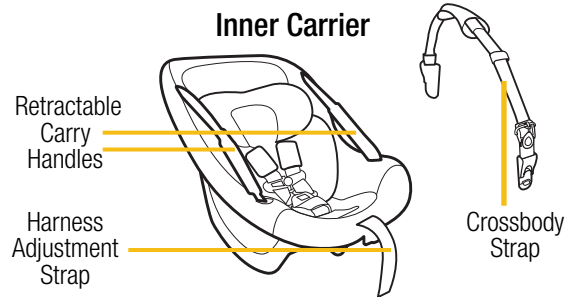

Back of Outer Carrier

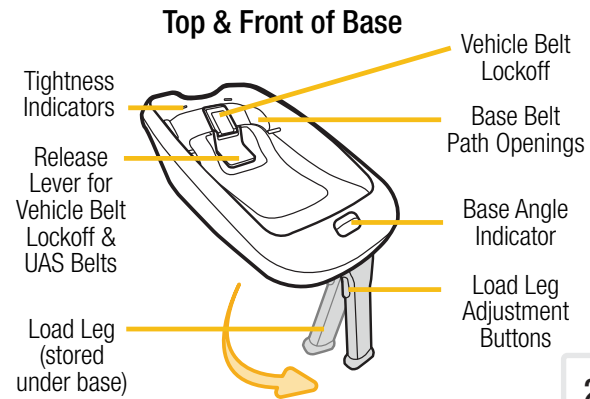
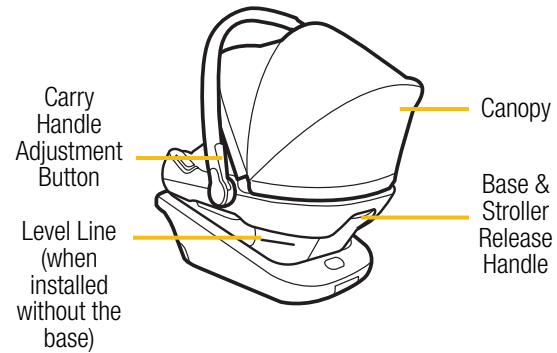

1

2

continued on next page

Front of Inner Carrier

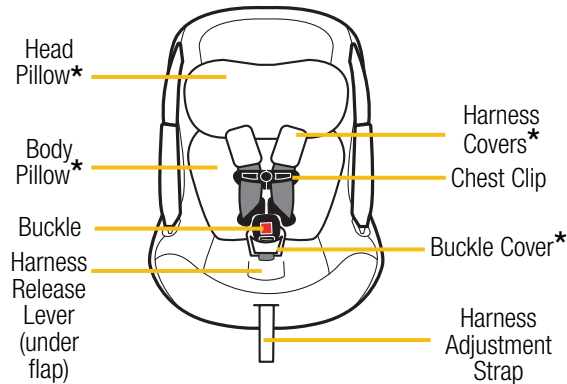

Back of Inner Carrier

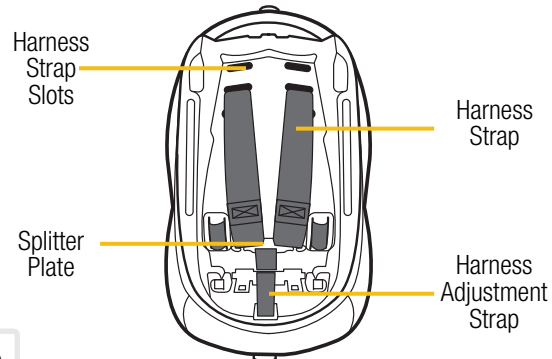

3

*See pages 4 & 5 for Accessory Use.

Accessory Use

For wash and care instructions, see page 69.



Head Pillow

When using the head pillow, make sure it does not cover your infant's face in any way.

You **must use** the head pillow for children who weigh **1.8-3.6 kg** (4-8 lb).

You may remove it for bigger infants.

To remove, pull it off of the harness straps.



Body Pillow

The body pillow provides comfort and helps achieve a snug harness fit.

To learn how to check harness tightness, see pages 16-18.

You **must use** the body pillow for children who weigh **1.8-3.6 kg** (4-8 lb).

You may remove it for bigger infants.

To remove, pull it out from behind the harness straps.

4

continued on next page



Harness Covers

The harness covers help provide comfort to your infant's neck. If the harness covers will not allow proper positioning of the chest clip or interfere with getting a tight enough harness fit, remove and **do not** use.

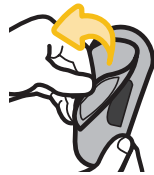

Store until your infant is large enough to use the harness covers while maintaining a properly fitting harness.

To remove, pull the fastening strips apart and pull the harness covers off of the harness strap.

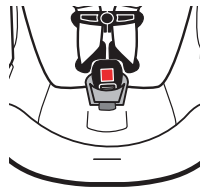

Buckle Cover

To remove, pull up on the buckle cover and slide it off of the buckle and pull it out of the buckle slot in the seat pad.

Rear-Facing Use Requirements



Measure your infant's weight and height (do not guess) before using this car seat.

Your infant's height, weight, and age determine how the car seat should be placed in the vehicle.

Children vary widely in body size, shape, and temperament—**please consult your doctor before switching between any types or modes of a car seat within the limits and fit requirements of the car seat.**

Provincial Laws

Please be certain to follow your province's laws regarding car seat use.

American Academy of Pediatrics Recommendations

Infants and Toddlers

Should ride in a rear-facing car seat as long as possible, until they reach the highest weight or height allowed by their seat.

Toddlers and Preschoolers

Once they are facing forward, children should use a forward-facing car seat with a harness for as long as possible, until they reach the height and weight limits for their seats.

continued on next page

School-Aged Children

Once they have outgrown their forward-facing car seat, children should use a belt-positioning booster seat until the vehicle's lap and shoulder seat belt fits properly. This is often when they have reached at least 4 feet 9 inches in height and are 8 to 12 years old.

Older Children

All children younger than 13 years should be restrained in the rear seats of vehicles for optimal protection.

This car seat can only be used **REAR-FACING.**

1.8-10 kg (4-22 lb) and 74 cm (29 in.) or less in height

Children under 1 year of age **must ride Rear-Facing.**

Your infant can remain in this car seat until they outgrow any one of the following:

- **Weight Limit:** 10 kg (22 lb); **OR**
- **Height Limit:** 74 cm (29 in.); **OR**
- **Infant Fit:** See page 11

7

Preparing Car Seat for Infant Fit

1

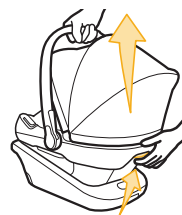

Remove Outer Carrier From Base

- From the back of the outer carrier, slide the base release handle up.
- Then lift the outer carrier out of the base.

2

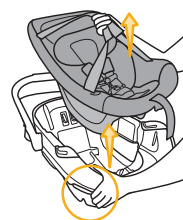

Remove Inner Carrier from Outer Carrier

- From the front of the outer carrier, squeeze one of the inner carrier release buttons.
- Lift the inner carrier out of the outer carrier.

8

continued on next page

3

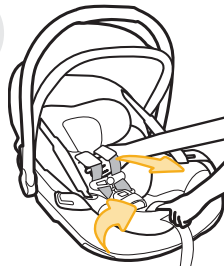

Loosen Harness Straps

- Locate the harness release lever through the opening in the pad.
- Push and hold down the harness release lever.
- Then pull both harness straps out together as shown.

4

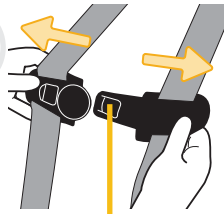

Release Button

Release Chest Clip

- Hold each side of the chest clip.
- Press the release button with your thumb.
- Pull the chest clip apart.

5



Buckle Tongue

Unbuckle Harness

- Press the red button.
- Pull the buckle tongues out.

6



Place Infant in Inner Carrier

Your infant's bottom and back should be flat against the inner carrier.

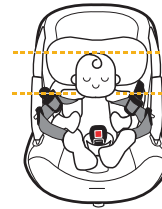

Check for Proper Fit

See page 11.



Head and Body Pillow

You **must** use the head and body pillow for children who weigh **1.8-3.6 kg** (4-8 lb).

You may remove them for bigger infants.

To remove, see page 4.

Checking Your Infant's Fit

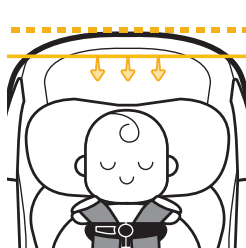

Head Position

The top of your infant's head **must be at least 2.5 cm (1 in.) below** the top of the inner carrier.

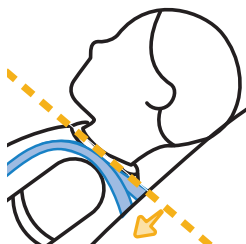

Harness Strap Position

The harness strap **must be at or slightly below** your infant's shoulders; **never above.**

Need to make adjustments?

To change harness height, see pages 16-18.

Securing Infant in Inner Carrier

1



Place Infant in Inner Carrier

- Your infant's bottom and back should be flat against the inner carrier.
- Position the harness straps over your infant's shoulders and upper thighs.

2

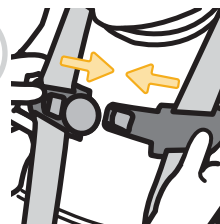

Fasten Chest Clip

- Insert the right half of chest clip into the left half.
- Snap together.

3

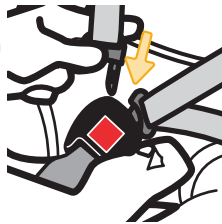

Buckle Harness

- Push the buckle tongues into the buckle until you hear them “click”.
- Pull up on the harness straps to make sure the buckle is locked.

4

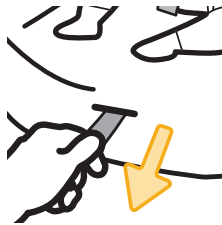

Tighten Harness

Pull the harness adjustment strap straight out to snugly tighten the harness system.

5

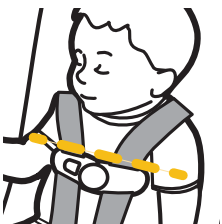

Position Chest Clip

- Slide the chest clip up the harness straps.
- Position it mid-chest (even with armpits) and away from your infant's neck.

6

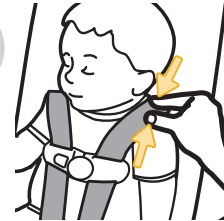

Check Tightness

- Unfasten the harness covers.
- Try to vertically pinch the harness strap at your infant's shoulder between your index finger and thumb as shown.
- If your fingers slip off, the harness system is tight enough.
- If you can pinch the harness strap, tighten more.
- Fasten the harness covers.

A snug strap should not allow any slack.
It lies in a relatively straight line without sagging.
It does not press on the infant's flesh or push the infant's body into an unnatural position.

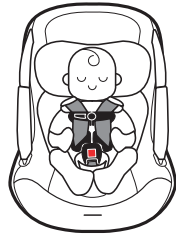

Finished!

Your infant is now secured in the inner carrier.

Check your infant's fit often and make any needed adjustments to the inner carrier as they grow.

To Remove Infant from Inner Carrier:

1. Loosen Harness Strap
2. Unbuckle Harness
3. Release Chest Clip
4. Remove Infant



Failure to fasten and tighten the harness system correctly may allow the infant to be ejected from the infant restraint in a crash or sudden stop causing serious injury or death.

Do not mistake comfort for safety. The harness system must be snugly adjusted.



Do not put snowsuits or bulky garments on your infant when placing them in the infant restraint. Bulky clothing can prevent the harness straps from being tightened properly.

Changing Harness Strap Position

1

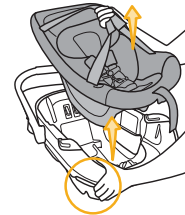

Remove Inner Carrier from Outer Carrier

- From the front of the outer carrier, squeeze one of the inner carrier release buttons.
- Lift the inner carrier out of the outer carrier.

2

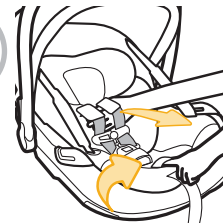

Loosen Harness Straps

3

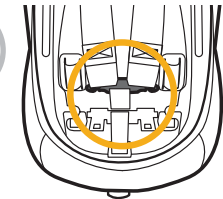

Turn Inner Carrier Over & Locate Splitter Plate

continued on next page

4

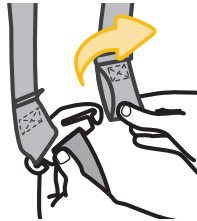

Remove Harness Strap Loops From Splitter Plate

5

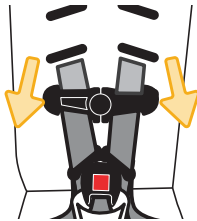

From Front of Inner Carrier, Pull Harness Straps Out of Shoulder Harness Slots

6

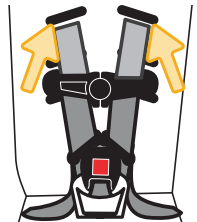

Rethread Harness Strap Into Correct Shoulder Harness Slots For Your Infant

For Infant Fit, see page 11.

17

7

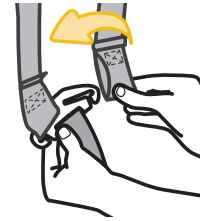

Attach Harness Strap Loops to Splitter Plate

- The sewn ends of the harness strap loops **must face** towards you.
- **Do not** twist the harness strap or the harness adjustment strap.
- Make sure the harness strap loops are fitted completely on both sides of the splitter plate.

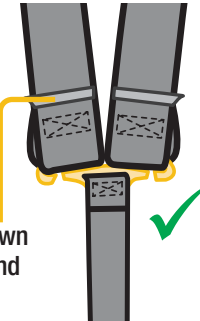

Check your infant's fit often.

Check the harness straps often for any wear or damage.

! The harness system must be installed correctly. Do not use an infant restraint with damaged harness straps.

18

Outer Carrier & Base: Removing & Installing



Removing Outer Carrier From Base

- From the back of the outer carrier, slide the base release handle up.
- Then lift the outer carrier out of the base.

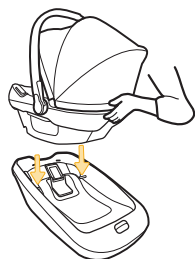

Installing Outer Carrier to Base

- Align the slots on the sides of the outer carrier with the lock bars in the base.
- Push down firmly on the carry handle and the front of the outer carrier to lock it to the base.
- Pull up on the front two corners of the outer carrier to make sure it's locked to the base.

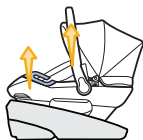

19

Outer Carrier Use with Inner Carrier

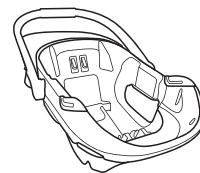

Used For:

- Attaching to compatible strollers.
- Attaching to the base when the base is installed in the vehicle.
- Carrying with the inner carrier installed to the outer carrier.

 **Never put an infant in the outer carrier.**

Carry Handle Use

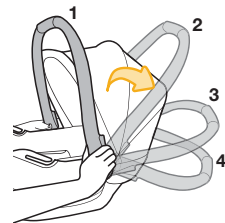

- Squeeze both buttons on the carry handle.
- Rotate the carry handle up or down to the desired location.
- Release the buttons.
- Make sure both buttons are locked into position.



The carry handle must be locked in position 1 when carrying and locked in position 1 or position 2 when installed in the vehicle.

20

Inner Carrier & Outer Carrier: Removing & Installing

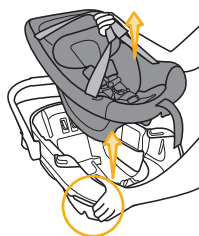

Removing Inner Carrier from Outer Carrier

- From the front of the outer carrier, squeeze one of the inner carrier release buttons.
- Lift the inner carrier out of the outer carrier.

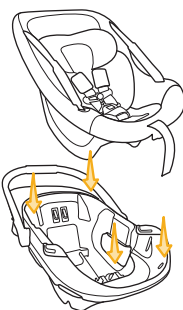

Installing Inner Carrier to Outer Carrier

- Hold the retractable carry handles together.
- Lower the inner carrier into the outer carrier.
- Push down firmly on the inner carrier to lock it to the outer carrier.
- Pull up on the front two corners and the back of the inner carrier to make sure it's locked to the outer carrier.

21

Inner Carrier Use

Used For:

- Carrying when it is installed to the outer carrier or without the outer carrier.
- Attaching to the outer carrier when installed in the vehicle.
- Attaching to compatible strollers using the inner carrier stroller adapter.



Coral XP inner carrier stroller adapter is sold separately. Visit maxicosi.com for more information.

⚠ Do not install the inner carrier in the vehicle without installing it to the outer carrier.

Crossbody Strap Use (optional carry mode)

Installing Crossbody Strap

1

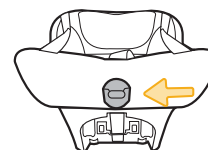

Locate Attachment Hubs at Top and Bottom of Inner Carrier

continued on next page

22

23

2

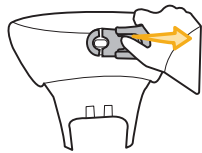

With Your Thumb, Pull Down Locking Lever to Expand Attachment Openings

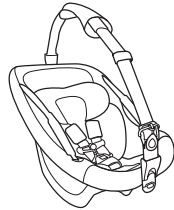
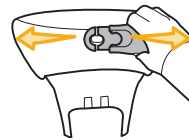

3



Secure Infant in Inner Carrier

- Attach to the hubs.
- Release the locking lever to secure the strap.
- Pull on the strap to check if it is locked into place.
- Start with the Crossbody Strap in the shortest length. Once you put it on, it will be easier to lengthen. See page 25.

23

24



Place Crossbody Strap Over Your Shoulder to Check For Fit

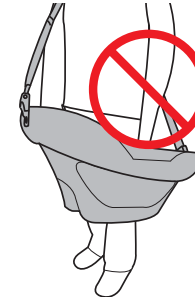

⚠ Always keep one hand on the inner carrier while using the Crossbody Strap.

Your infant must always be snugly secured in the inner carrier.

The Crossbody Strap may remain attached to the inner carrier when it has been installed in the outer carrier and when the outer carrier is installed in the vehicle with or without the base.

To adjust length of the Crossbody Strap, see page 25.

24

Adjusting Length of Crossbody Strap

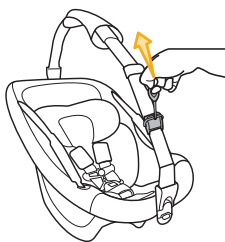

To Shorten

- Place inner carrier on a stable flat surface.
- Locate the pull ring on the Crossbody Strap.
- Pull the ring up to shorten.



To Lengthen

- Locate the pull ring on the Crossbody Strap.
- Pull the ring down to lengthen.

Removing Crossbody Strap

1

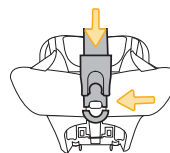

Locate Attachment Hubs at Top and Bottom of Inner Carrier

2

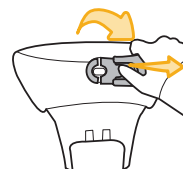

With Your Thumb, Pull Down Locking Lever to Expand Attachment Openings

- Remove from hubs.

Store in a safe place until ready for next use.
For wash and care instructions, see page 69.

WARNINGS

Read ALL instructions before using infant restraint as a carrier.

NEVER use carrier unless infant is properly secured.

Use only as a carrier by children weighing 1.8-10 kg (4-22 pounds) and 74 cm (29 inches) or less in height.

NEVER leave infant unattended. Always keep infant within arm's reach.

Suffocation Hazard: Infant carrier can roll over on soft surfaces and suffocate infant. **NEVER** place carrier on beds, sofas or other soft surfaces. Keep infant's face free from obstructions at all times.

Strangulation Hazard: Children have **STRANGLED** in loose or partially buckled harness straps. Fully restrain the infant even when carrier is used outside the vehicle.

Fall Hazard: Infant's movement can slide carrier. **NEVER** place carrier on counter tops, tables or any other elevated surface.



The carrier can fall from the shopping cart. Do not use on shopping cart.

Leaning, bending over, or tripping can cause infant to fall. Always keep one hand on the inner carrier while using the Crossbody Strap.

NEVER use the inner carrier as a means to transport an infant in a motor vehicle without installing it to the outer carrier.

27

Do not use the carrier if it is damaged or broken, or if any parts are missing.

Adjusting Base

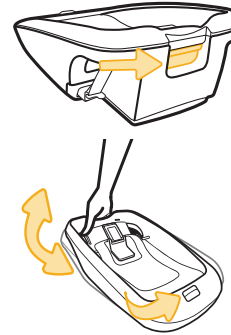

The base has multiple positions to help achieve the correct recline angle.

- The adjustment handle is at the back of the base.
- Squeeze the adjustment handle.
- Lift the back of base up.
- Then release the handle so the base foot locks into a position.
- The **horizontal** section of the angle indicator will turn **completely green** when correct. No red should be showing.

Base Recline Angle Position

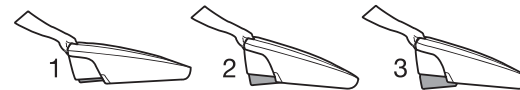

28

Load Leg



The load leg is stored under the base. This is an optional feature.

The base install is equally safe with or without the use of the load leg.

In a crash, load legs can reduce downward rotation, limit rebound, provide additional stability, and energy absorption.

- Fold the load leg out.
- Squeeze the buttons on the load leg and pull it down until it meets the vehicle floor.
- Release the buttons.
- Lift the front of the base while holding the load leg in place to lock it into position.
- It **must be** perpendicular to the vehicle floor.

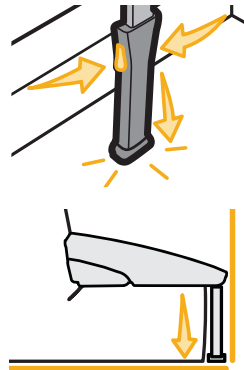

⚠ Do not use the load leg on top of vehicle storage compartments. Review your vehicle owner's manual. Do not use the load leg if it does not reach the floor of your vehicle. When not in use, the load leg must be stored under the base.

Release Lever for Vehicle Belt Lockoff & UAS Belts

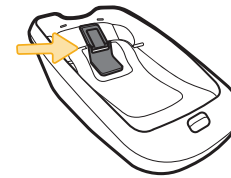

This base has a release lever that has two functions; one for UAS belts and one for vehicle belts.

Lockoffs prevent the vehicle belt from loosening after tightening.

Opening Release Lever

Lift release lever to open Lockoff and release UAS belts.

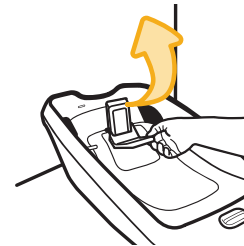

Closing Release Lever

Push down on lever to close Lockoff and to allow the UAS belts to retract.

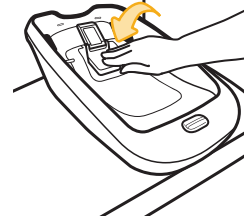

For UAS Belt with Base Install | Page 43



- You **must Lift the Release Lever** in order for the UAS belts to loosen.
- You **must Push the Release Lever Down** in order for the UAS belts to tighten.

For Vehicle Belt with Base Install | Page 49



- You **must Lift the Release Lever** in order to thread the lap belt or the lap/shoulder belt under both the belt path guides and the Lockoff.
- You **must** tighten the vehicle belt **BEFORE Pushing the Release Lever Down** to close the Lockoff.
- The vehicle belts **must be** completely under the Lockoff.

Tightness Indicators

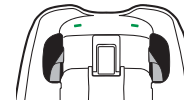

This base has indicators that show when the UAS belt or vehicle belt have been securely tightened.

The red will turn **completely green** when tightened correctly. No red should be showing.

For more information about how to tighten, see the base install section you will be using:



UAS Belt
with Base Install
Page 43



Vehicle Belt with Base Install
Page 49

UAS Use

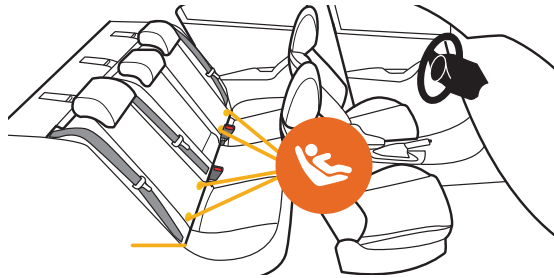

Your vehicle's features may be considerably different than those pictured here.

The Universal Anchorage System (UAS) is a universal system for installing infant restraints without using vehicle seat belts. The UAS system can **ONLY** be used in vehicles that have the UAS anchor bars installed and designated UAS seating positions. Most vehicles manufactured after September 2002 are equipped with UAS. Check your vehicle owner's manual to see which seating positions may be equipped with the UAS system.

⚠ Do not use both the UAS belt and vehicle belt at the same time.

When used correctly the UAS belt or the vehicle belts are equally safe.

33

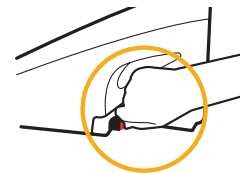

Removing Connectors from Storage Location

- Press in red button. Push connector into storage location.
- Then pull it and the belt out.

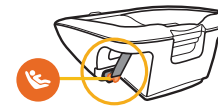
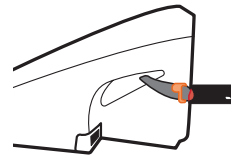

Storing UAS Belt

When using the vehicle belt to install or when the base is not installed in a vehicle, attach the connectors to the attachments in the base as shown.



Removing UAS Belt from Vehicle Anchor Bars

Press the red release button on each connector, then pull the connectors out of the vehicle seat.

34

Vehicle Belt Use

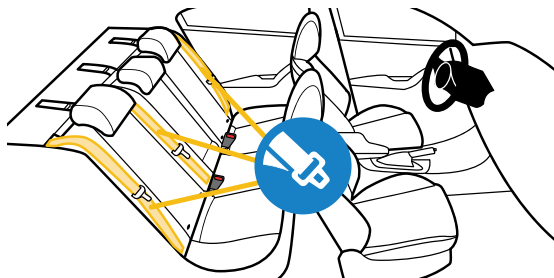

Your vehicle's features may be considerably different than those pictured here.

If UAS is not an option, you **must** use the vehicle seat belt system to install the car seat.

Not all vehicle belts and seating positions will work with car seats.

Please go through the steps on the next page to understand how to lock a car seat with a vehicle belt.

 **Do not use both the UAS belt and vehicle belt at the same time.**

35

When used correctly the UAS belt or the vehicle belts are equally safe.

1



You Must Review Your Vehicle Owner's Manual

Your vehicle owner's manual will let you know which vehicle belts and seating positions car seats can be installed in.

2



Check How This Car Seat Will Be Locked Into Place

The vehicle belt **must not** loosen after tightening. There needs to be a way to lock the vehicle belt.

The ways to lock a vehicle belt are:

- By using this base's Lockoff, see step 3; **OR**
- By using the seat belt's retractor, see step 4; **OR**
- By using the seat belt's latch plate, see step 5.

36

continued on next page

3

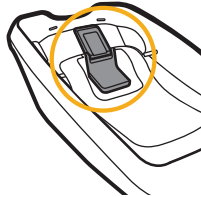

Lockoff

When used correctly, this base's Lockoff will lock the vehicle belt.

Please go to the vehicle belt with base installation section of the manual to see how to properly use this feature.

Vehicle Belt with Base Install | Page 49

If you will be installing without the base, you **must** lock the vehicle belt using the retractor or the latch plate; continue to step 4.

4

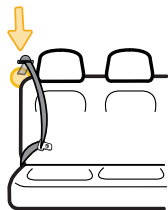

Check Retractor

Retractors pull seat belts into stored positions and lock the belt to hold passengers in place.

See the next page for some common types of vehicle belt retractors that will work with this car seat.

37

Types of Retractors

Switchable Retractor
(most vehicles have this type)



This retractor can be switched to a locking mode.

You **must have the retractor in the locking mode** to use the seat belt with this car seat.

Switching to locking mode: Slowly pull the shoulder belt all the way out, then let it go back in **2.5-5 cm** (1-2 in.).

As it goes back in, you will most likely hear a ratcheting sound.

Gently pull the belt to see if it has locked. You will not be able to pull any more belt out if the lock has engaged.

Automatic Locking Retractor



This retractor always locks.

It will automatically lock after slowly pulling the seat belt out at least halfway and letting the belt go back into the retractor **2.5-5 cm** (1-2 in.).

38

continued on next page

Emergency Locking Retractor

See Step 5, "Check Latch Plates".

If the retractor does not lock, it is most likely an Emergency Locking Retractor. These retractors only lock during a sudden stop or collision.

You will need to determine if your seat belt's latch plate can lock the belt. See step 5, "Check Latch Plates".

5



Check Latch Plates

Latch plates are the part of the seat belt that goes into the buckle.

To see if the latch plate locks:

1. Buckle Vehicle Belt
2. Firmly Tug Lap Portion of Seat Belt While Pulling It Up

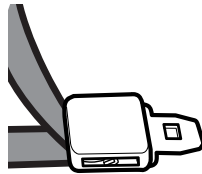

Locking Latch Plate

If the vehicle belt does not slide through the latch plate, it's locked.

39

If the latch plate slides up and down the vehicle belt, it is a **sliding latch plate**.

Sliding latch plates easily slip between the lap and shoulder portions of the belt.

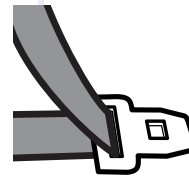

Emergency Locking Retractor with a Sliding Latch Plate

If you have an Emergency Locking Retractor with a Sliding Latch Plate, you must use a locking clip.

Please contact us for one, see page 87.

Never Use With This Car Seat

Emergency Locking Retractor Lap Only Belt



Inflatable Seat Belts



40

Rear-Facing Use with Base

**1.8-10 kg (4-22 lb) and
74 cm (29 in.) or less in height**



Lap/Shoulder Belt



Lap Belt



UAS Belt



Never install a rear-facing infant restraint in the front seat of a vehicle equipped with an active frontal airbag.

Check the vehicle belt or the UAS belt before each use. Use only if the belt can be tightened properly and locked securely in place.

Do not fasten multiple UAS belt connectors on the same UAS anchor bar in the vehicle.

Infant restraint must be securely attached to base.

Do not use the load leg on top of vehicle storage compartments. Review your vehicle owner's manual.

Do not use the load leg if it does not reach the floor of your vehicle.

Do not refer to the level line on the shell when installing with the base.

This infant restraint must always face the rear of the vehicle.

Failure to follow these warnings can result in serious injury or death.

UAS Belt Install with Base

Before you begin installing the base into your vehicle, did you check:

Your infant's weight and height? See page 7.

Your infant's fit? See page 11.

1



Unfold Load Leg

This is an optional feature.

In a crash, load legs can reduce downward rotation, limit rebound, provide additional stability, and energy absorption.

 **Do not** fully extend yet.

 **Do not** use the load leg to adjust the base angle.

Review your vehicle owner's manual for load leg use.

43

2

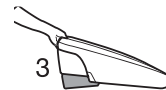
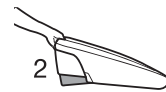
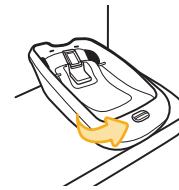

Check Base Angle

The angle indicator will turn **completely green** when correct. No red should be showing.

Adjusting the Base

If the angle indicator is not correct, adjust the base foot.

There are 3 positions.

- The adjustment handle is at the back of the base.

- Squeeze the adjustment handle to release the base foot.

- Then release the handle so the base foot locks into one of the positions.

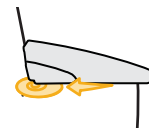

NOTE: Only if necessary, you may need to place a tightly rolled towel(s) or foam pool noodle(s) under the back of the base to help get the correct angle. Check the padding often to make sure it is still in place.

44

continued on next page

3

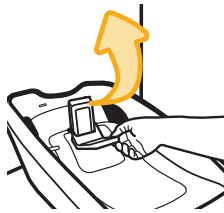

Lift Release Lever

You must **Lift the Release Lever** in order for the UAS belts to loosen.

4

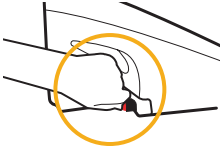

Release UAS Connectors from Storage Location

- Press in red button. Push connector into storage location.
- Then pull it and the belt out.

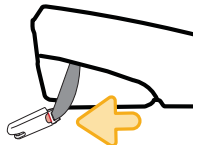

Attach Connectors to Vehicle Anchors

Review your vehicle owner's manual for UAS anchor locations and UAS anchor use.

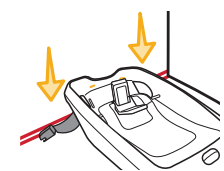

5

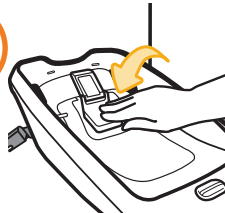

Push Release Lever Down

You must **Push the Release Lever Down** in order for the UAS belts to tighten.

6



Push Down on Base to Tighten UAS Belts

The belts will begin to automatically retract and tighten as you push down.

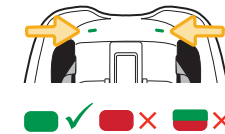

Check Tightness Indicators

The red will turn **completely green** when tightened correctly. No red should be showing.

You may need to **adjust the base foot** into another position for the tension indicators to turn completely green. See **step 2**.

You can also check the tightness by:

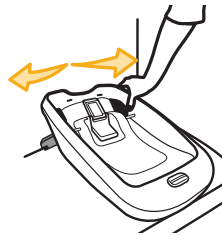

- Holding the base **ONLY at the belt path** with your non-dominant hand.
- Pushing and pulling from side to side.
- The base should not move more than **2.5 cm (1 in.)**.

If it moves more than 2.5 cm (1 in.), you can try:

- Pushing down on the base more; **OR**
- Reinstalling the base; **OR**
- Changing to a different seating location; **OR**
- Switching to vehicle belt installation

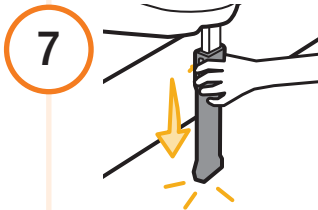

Extend Load Leg

- Squeeze the buttons on the load leg and pull it down until it meets the vehicle floor.
- Release the buttons.

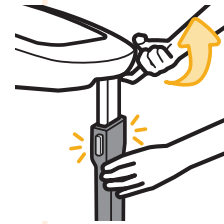

- Lift the front of the base while holding the load leg in place as shown to lock it into position.
- It **must be** perpendicular to the vehicle floor.

⚠ Do not use the load leg if it does not reach the floor of your vehicle.

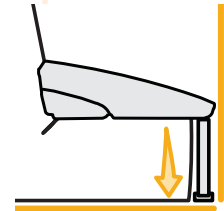

⚠ Do not use the load leg on top of vehicle storage compartments.

Review your vehicle owner's manual.

UAS Belt with Base Install Finished!

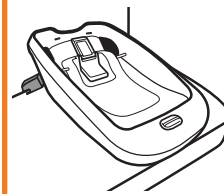

To install the outer carrier to the base, see page 55.

Check the tightness of the install often to make sure it has not loosened.

Vehicle Belt Install with Base

Before you begin installing the base into your vehicle, did you check:

Your infant's weight and height? See page 7.

Your infant's fit? See page 11.

1



Unfold Load Leg

This is an optional feature.

In a crash, load legs can reduce downward rotation, limit rebound, provide additional stability, and energy absorption.

 **Do not** fully extend yet.

 **Do not** use the load leg to adjust the base angle.

Review your vehicle owner's manual for load leg use.

49

2

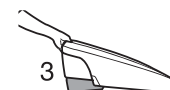
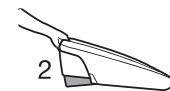
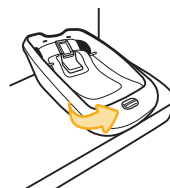

Check Base Angle

The angle indicator will turn **completely green** when correct. No red should be showing.

Adjusting the Base

If the angle indicator is not correct, adjust the base foot.

There are 3 positions.

- The adjustment handle is at the back of the base.
- Squeeze the adjustment handle to release the base foot.
- Then release the handle so the base foot locks into one of the positions.

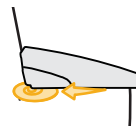

NOTE: Only if necessary, you may need to place a tightly rolled towel(s) or foam pool noodle(s) under the back of the base to help get the correct angle. Check the padding often to make sure it is still in place.

50

continued on next page

3

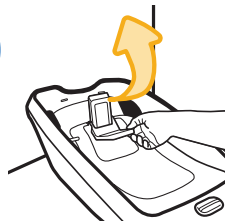

Lift Release Lever



Check if Your Vehicle Belts Will Work With This Car Seat



Review pages 35-40 and your vehicle owner's manual to find out what kind of vehicle belts you have.

4

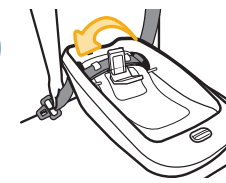

Route Belt Through Belt Path Openings As Shown

The lap belt or the lap/shoulder belt both go **completely under** the belt path guides and the Lockoff as shown.

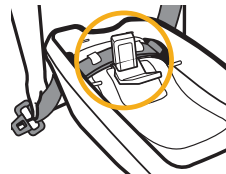

Buckle the vehicle belt.

51

5



Push Down on Base While Tightening Belt

You **must** tighten the vehicle belt **BEFORE** closing the Lockoff.

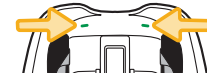

Check Tightness Indicators

The red will turn **completely green** when tightened correctly. No red should be showing.

You may need to **adjust the base foot** into another position for the tension indicators to turn completely green. See **step 2**.

6

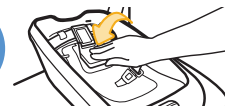

Push Release Lever Down

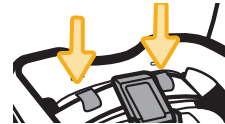

The lap belt or the lap/shoulder belt both go **completely under** the belt path guides and the Lockoff as shown.

After the base has been installed, if your car has a switchable retractor, you may also use it to lock the belt. **If the Lockoff cannot be used properly**, then do not install the base using vehicle belt installation. See page 43 for UAS install.

52

continued on next page

You can also check the tightness by:

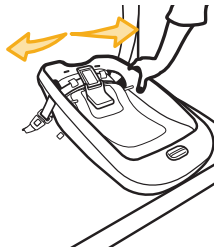

- Holding the base **ONLY at the belt path** with your non-dominant hand.
- Pushing and pulling from side to side.
- The base should not move more than **2.5 cm (1 in.)**.

If it moves more than 2.5 cm (1 in.), you can try:

- Tightening the belt more; **OR**
- Reinstalling the base; **OR**
- Changing to a different seating location; **OR**
- Switching to UAS belt installation

7

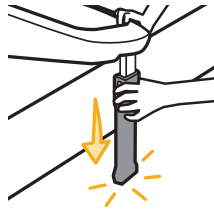

Extend Load Leg

- Squeeze the buttons on the load leg and pull it down until it meets the floor of the vehicle.
- Release the buttons.

53

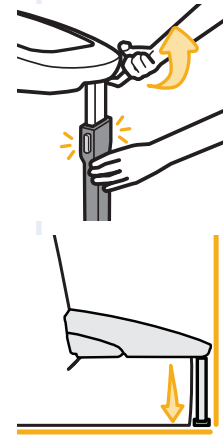

- Lift the front of the base while holding the load leg in place as shown to lock it into position.
- It **must be** perpendicular to the vehicle floor.

⚠ Do not use the load leg if it does not reach the floor of your vehicle.

⚠ Do not use the load leg on top of vehicle storage compartments.

Review your vehicle owner's manual.

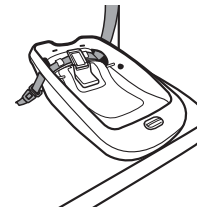

Vehicle Belt with Base Install Finished!

To attach the outer carrier to the base, see page 55.

Check the tightness of the install often to make sure it has not loosened.

54

Installing Outer Carrier to Installed Base

Illustrations show the base installed with the UAS belt; however, the same steps apply for a vehicle belt install.

1

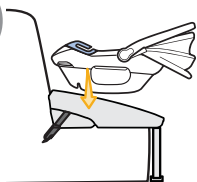

Install Outer Carrier to Base

Pull up on the front two corners and the back of the outer carrier to make sure it's locked to the base.

2



Secure Infant in Inner Carrier

To properly secure your infant in the inner carrier, see pages 12-15.

3



Install Inner Carrier to Outer Carrier

Pull up on the front two corners and the back of the inner carrier to make sure it's locked to the outer carrier.

55

4



Carry Handle Must Be Locked and in Position 1 or Position 2

5

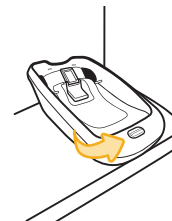

Recheck Angle Indicator on Base

Redo the base installation if the angle indicator is not correct.

UAS Belt Base Install | Page 43
Vehicle Belt Base Install | Page 49

UAS Belt Install



Vehicle Belt Install



56

Rear-Facing Use Without Base

**1.8-10 kg (4-22 lb) and
74 cm (29 in.) or less in height**

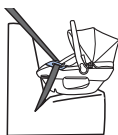

Lap/Shoulder Belt



Lap Belt



Never install a rear-facing infant restraint in the front seat of a vehicle equipped with an active frontal airbag.

Check the vehicle belt before each use. Use only if the belt can be tightened properly and locked securely in place.

This infant restraint must always face the rear of the vehicle.

Failure to follow these warnings can result in serious injury or death.

57

Vehicle Belt Install Without Base

Before you begin installing the seat into your vehicle, did you check:

Your infant's weight and height? See page 7.

Your infant's fit? See page 11.

1



Secure Infant in Inner Carrier

To properly secure your infant in the inner carrier, see pages 12-15.

2

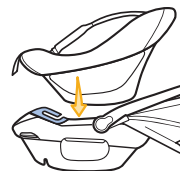

Install Inner Carrier to Outer Carrier

Pull up on the front two corners and the back of the inner carrier to make sure it's locked to the outer carrier.

continued on next page

58

3

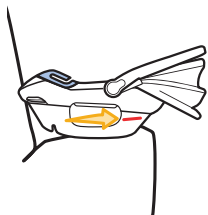

Place Outer Carrier into Vehicle Rear-Facing

Check Level Line

The level line on the side of shell must be parallel with the ground.



NOTE: You may need to place a tightly rolled towel(s) or foam pool noodle(s) under the front of the outer carrier to help get the correct angle.

Check the padding often to make sure it is still in place.



Check if Your Vehicle Belts Will Work With This Car Seat



Review pages 35-40 and your vehicle owner's manual to find out what kind of vehicle belts you have.

4

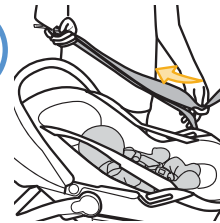

Route Vehicle Lap or Lap/Shoulder Belt Through Belt Guides on Both Sides of Shell

Buckle the vehicle belt.

If your car's vehicle belt has a switchable retractor, use it to lock the vehicle belt.

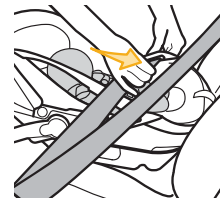

For information about switchable retractors, see page 38 or review your vehicle owner's manual.

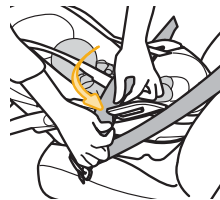

5

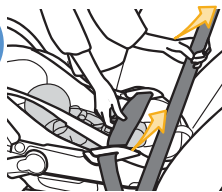

Tighten Belt

Pull the shoulder belt or the free end of the lap belt to tighten.

Lock the seat belt. See pages 37-40.

6

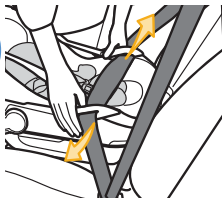

Check Belt Tightness

- Hold the car seat **ONLY at the belt path** with your non-dominant hand.
- Push and pull from side to side.
- It should not move more than **2.5 cm** (1 in.).

If it moves more than 2.5 cm (1 in.), you can try:

- Pulling the belt tighter; **OR**
- Reinstalling the car seat; **OR**
- Changing to a different seating location

7

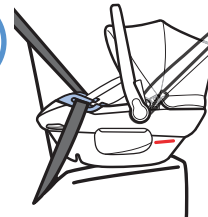

Recheck Level Line

Redo the installation if level line is not parallel with the ground.

8

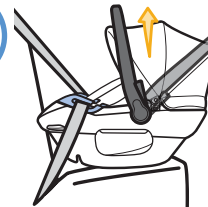

Carry Handle Must Be Locked and in Position 1 or Position 2

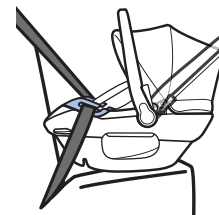

Vehicle Belt Install without Base Finished!

Check the tightness of the install often to make sure it has not loosened.

Removing Harness System

You must partially remove the harness system in order to remove the pad.

To remove accessories, see pages 4-5.

1

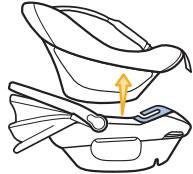

Remove Inner Carrier from Outer Carrier

2

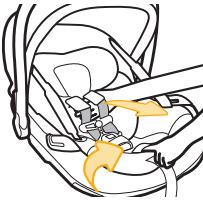

Loosen Harness Straps

3

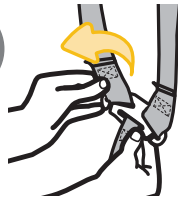

Turn Inner Carrier Over and Remove Harness Strap Loops From Splitter Plate

63

4

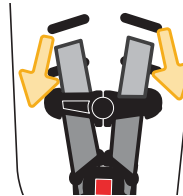

From Front of Inner Carrier, Pull Harness Straps Out of Shoulder Harness Slots

5

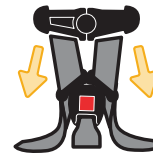

Unthread Chest Clip

6



Unthread Buckle
Do not unbuckle.
The buckle cannot be removed from the inner carrier.



You Do Not Need to Completely Remove Harness Strap from Inner Carrier to Remove Pad

64

Removing Seat Pad

You must partially remove the harness system in order to remove the pad. See pages 63-64.

1

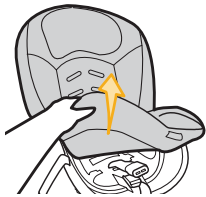

Pull Seat Pad off of Bottom of Inner Carrier

Pull harness adjustment strap, harness strap, and buckle through the slots in the pad.

2



Pull Seat Pad off of Top and Sides of Inner Carrier

3

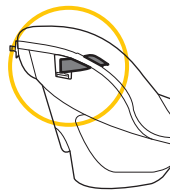

Locate Retractable Carry Handles' Metal Retainers

65

4

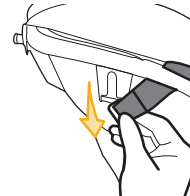

Pull Metal Retainers Down and Out of Slot in Inner Carrier

5

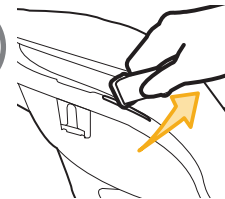

Pull Metal Retainers Out of Slot in Shell

6

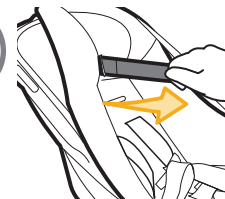

Pull Retractable Carry Handle Out of Seat Pad Slot

66

continued on next page

7



Pull Seat Pad
Around and Off of
Retractable Carry
Handle Guide

8

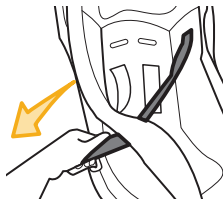

Pull Retractable
Carry Handles Out
of Pad

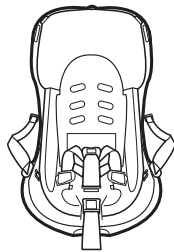

Finished!

67

Removing & Installing Canopy

Removing Canopy

1

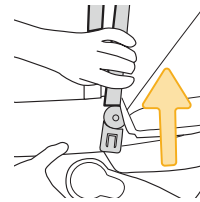

Pull Canopy Hub
Off of Outer Carrier

For wash and care instructions, see page 69.

Installing Canopy

1

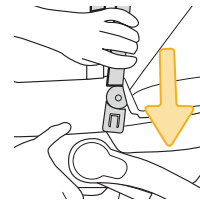

Attach Canopy Hubs
to Outer Carrier

2

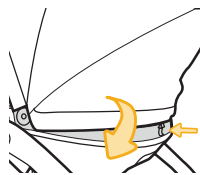

Pull Canopy Over
Back of Outer
Carrier Edge

68

Cleaning Parts of Car Seat

Cleaning Seat Pad, Head & Body Pillows, & Buckle & Harness Covers

Machine wash separately with cold water on a gentle cycle. Make sure the harness covers are closed so the fastening strips are not exposed. Do not use bleach. Tumble dry separately for 10-12 minutes on low heat. Remove immediately.

Cleaning Canopy

Spot clean using warm sudsy water and damp cloth. Line dry.

Cleaning Harness Strap

Check the harness straps often for any wear or damage.

Spot clean using warm sudsy water and damp cloth. Spilled food and liquids on the car seat may result in mold or bacterial growth over time. These spills could also attract insects or rodents.

Cleaning Buckle, Crossbody Strap, & Inner and Outer Carriers

Spot clean using warm sudsy water and damp cloth. Do not submerge into water.

69

⚠ Do not use the infant restraint without the seat pad or with damaged harness straps.

Installing Seat Pad

1



Pull Harness Straps Through Slots in Seat Pad

2

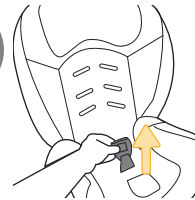

Pull Buckle Through Buckle Slot in Seat Pad

3

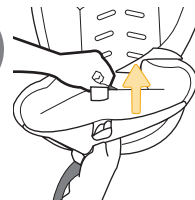

Pull Harness Adjustment Strap Through Slot in Seat Pad

70

continued on next page

4

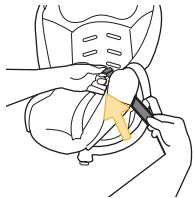

Pull Carry Handles Through Slots in Seat Pad

5



Push Top of Retractable Carry Handles Through Slots at Top & Sides of Seat Pad

Do not twist the retractable carry handles.

6

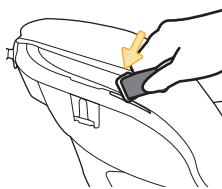

Push Retractable Carry Handles' Metal Retainers Down Through Slots in Inner Carrier

7

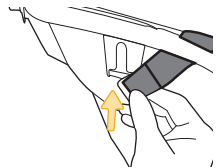

Push Retractable Carry Handles' Metal Retainers Up into Slots in Inner Carrier

8

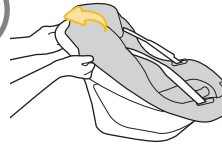

Pull Seat Pad Around Top of Inner Carrier

9

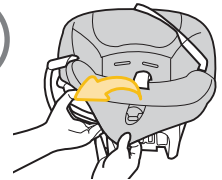

Pull Seat Pad Down Around Bottom of Inner Carrier & Around Carry Handle Guide



To install accessories, see pages 4-5.

Installing Harness System

If you have not removed the harness strap completely from the inner carrier, skip to step 4.

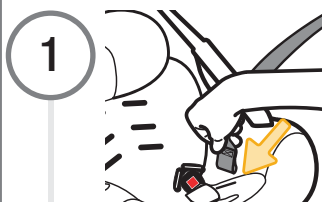

1 Thread Harness Strap

With the sewn end of the harness strap loop facing the buckle, thread the harness strap down through the hip harness slot.

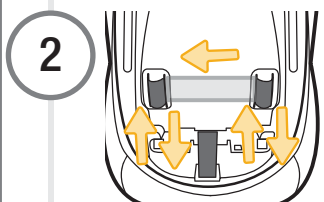

2 Lift Up Front of Pad and Weave Harness Strap In and Out of Shell As Shown

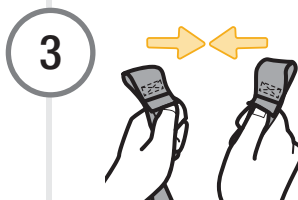

3 Make Harness Strap Even

The sewn ends of the harness strap loops **must** face each other.

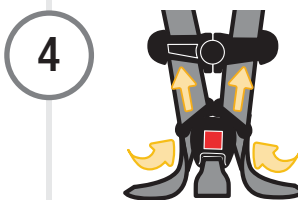

4 Thread Buckle and Chest Clip

The harness strap ends go through the **back** of the buckle tongues. Then they go through the chest clip **front to back** as shown.

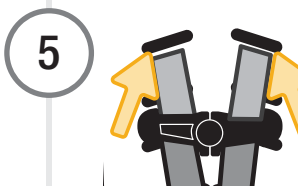

5 Rethread Harness Strap Into Correct Shoulder Harness Slots For Your Infant

6

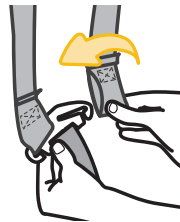

Attach Harness Strap Loops to Splitter Plate

- The sewn ends of the harness strap loops **must face** towards you.
- **Do not** twist the harness strap or the harness adjustment strap.
- Make sure the harness strap loops are fitted completely on both sides of the splitter plate.

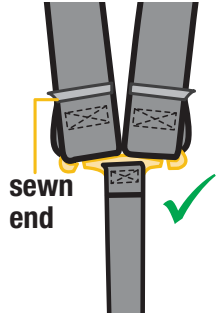

Check your infant's fit often.
Check the harness straps often for any wear or damage.

75

 The harness system must be installed correctly. Do not use an infant restraint with damaged harness straps.

Aircraft Information

This restraint is certified for aircraft use.

Install the car seat in a window seat to avoid blocking the aisle. If the aircraft lap belt is too short, ask the flight attendant for a belt extender.

Use only on forward-facing aircraft seats.

Contact the airline for their specific policies.

Some airlines may ask to see a label stating that this car seat is certified for aircraft use.

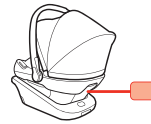

There is an airplane certification label located on the back of the outer carrier as shown.



Rear-Facing Aircraft Installation without Base

Follow pages 58-62.

You can only install this infant restraint in the aircraft without the base.

76

Replacement & Expiration of Car Seat

Do not risk your infant's safety.

To keep your infant as safe as possible, Dorel Juvenile Group strongly recommends replacing the car seat even after a minor crash; even if it was not occupied at the time.

Replacement After a Minor Crash

The National Highway Traffic Safety Administration states that for a crash to be considered minor

ALL of the following must be true:

- Vehicle able to drive away from the crash site; **AND**
- Vehicle door nearest the car seat was not damaged; **AND**
- No passengers were injured; **AND**
- Airbags did not deploy; **AND**
- There is no visible damage to the car seat.

If the crash your car seat was involved in meets **ALL** the criteria, you may not need to replace the car seat.

If one or more of these criteria are not true or if you are uncertain of any of your answers, replace the car seat immediately.

77

Replacement After a Moderate to Severe Crash

You **must** replace this car seat if it has been in a moderate to severe car crash.

This car seat is intended to protect an infant in a single crash.

During a crash, the car seat and all of its parts absorb crash energy which can deform or weaken it. Damage is not always visible. A damaged car seat must be replaced immediately.

Expiration

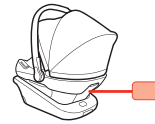

On the back of the outer carrier there is a date of manufacture label as shown.

Do not use this car seat more than 8 years after the date of manufacture.

78

Infant Restraint Use

Never take your infant out of the infant restraint while the vehicle is moving.

Never leave infant unattended.

Placing your infant in a hot infant restraint may result in burns.

Do not use an infant restraint with damaged or missing parts.

Do not use an infant restraint with cut, frayed, or damaged harnesses.

Do not substitute parts or try to modify the infant restraint in any way.

Do not lubricate buckles and fasteners.

Do not use any infant restraint accessory except those approved by Dorel Juvenile Group.

Never allow any infant to play with this infant restraint; it is not a toy.

Do not remove or cover up any of the warning labels or other labels on the infant restraint.

This infant restraint has been certified for use in passenger vehicles. Do not use in a boat, on a motorcycle or in a cargo van or bus where there are no seat belts.

Read all instructions for additional warnings.

Installation in Vehicle

Check the vehicle belt or UAS belt before each use. Use only if the belt can be tightened properly and locked securely in place.

Even when unoccupied, this infant restraint must be firmly secured to the vehicle with a UAS belt or with the vehicle seat belt.

In a crash or sudden stop, an unsecured infant restraint could injure occupants.

Vehicle Seating Position



Never place an infant rear-facing in a seating position with an active frontal air bag.

Check the vehicle owner's manual for more information about air bag/infant restraint use.



Use the infant restraint only on vehicle seats that face forward.



Do not use on seats that face the sides or rear of the vehicle.

For vehicles without a back seat, refer to your vehicle owner's manual.



Children are safer when properly restrained in rear seating positions than in the front seating positions.

According to accident statistics, children in rear seating positions are statistically safer, whether you have air bags, advanced air bags, or no air bags at all.

If you are not sure where to place the car seat in your vehicle:

- Consult your vehicle owner's manual, **OR**;
- Contact Dorel Juvenile Group Consumer Care Department, **OR**;
- Visit your local Child Passenger Inspection Station.

To avoid your infant being seriously burned, take the following precautions:

- Park in the shade or where sun does not directly hit the car seat.
- Cover the car seat with a sheet or blanket when not in use.
- Check for hot seat and buckles before placing infant in car seat.

To help protect your vehicle seat's upholstery from damage, use a single layer towel underneath and behind car seat.

Transport Canada Regulations

Transport Canada Road Safety Directorate regulates children's restraint systems under the Motor Vehicle Restraint Systems Safety Regulations (RSSR).

The regulations require the manufacturer and/or importer to certify the infant restraint to the applicable safety standards and place specified warnings and information on the labels fastened to each infant restraint and in this instruction manual.

Registration and Safety Notices

Although infant restraints are tested, evaluated, and certified by the manufacturer and tested by Transport Canada, it is possible that a safety-related problem may be found.

If there is ever a safety issue with your infant restraint, we use registration information to reach owners.

Online: www.djgusa.com/registration/carseat/can

Telephone: 1-800-951-4113

Mail: Send your name, address and your infant restraint's model number, manufacture date, line code and date of purchase to:

Dorel Juvenile Canada
Attn: Consumer Care
2855 Argentia Road, Unit 4
Mississauga, ON L5N 8G6

Please do not send in your registration card if you have registered your infant restraint online. For information on safety-related problems, you can also call Transport Canada's Road Safety Dept. at: 1-800-333-0371.

Example of model number, line code, and manufacture date.

Client: Simplement inscrire votre nom, adresse et courriel. S.V.P. imprimez. 

Your Name/Votre nom:

Your Street Address/Votre adresse:

City/Ville: Province: Postal Code/Code Postal:

Email Address (optional)/Courriel (optionnel):

AB123CDE **Maxi-Cosi Car Sea** **2015/05/16**

Date of Purchase/Date d'achat: **L#11 B265035**

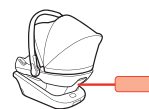

If you don't have the card or if your address changes, you will find the model number, manufacture date, and line code on the label located on the back of the outer carrier.

Warranty

Dorel Juvenile Group, Inc. (DJG) warrants this product to the original retail purchaser as follows: This product is warranted against defective materials or workmanship for one year from the date of original purchase. **An original receipt is required to validate your warranty.** DJG will, at its option, provide replacement parts or replace this product. DJG reserves the right to substitute if the part or model has been discontinued.

To make a claim under this warranty contact our Consumer Care Department by phone at 1-800-951-4113; or text us at 1-812-652-2525. Our hours of operation are from 8:00 a.m. to 6:00 p.m. EST Monday through Thursday and from 8:00 a.m. to 4:30 p.m. on Friday.

Proof of purchase is required and shipping charges are the responsibility of the consumer.

Warranty Limitations: This warranty does not include damages which arise from misuse or abuse of this product.

Limitation of Damages: The warranty and remedies as set forth are exclusive and in lieu of all others, oral or written, expressed or implied. In no

event will DJG or the dealer selling this product be liable to you for any damages, including incidental or consequential damages, arising out of the use or inability to use this product.

Limitation of warranties and other warranty terms and state law rights: Any implied warranties, including implied warranties of the merchantability and fitness for a particular purpose, shall be limited to the duration and terms of the express written warranty. Some states do not allow limitations as to how long an implied warranty lasts or the exclusion or limitation of incidental or consequential damages, so the above limitations may not apply to you.

This warranty gives you specific legal rights, and you may have other rights, which vary from state to state. Neither DJG nor the dealer selling this product authorized any person to create for it any other warranty, obligation, or liability in connection with this product.

Please note: Our product warranty only applies when purchased from an authorized Maxi-Cosi retailer. The origin of products not purchased through these authorized retailers is unknown and could be counterfeit.

continued on next page

We cannot support products from an unknown origin as we cannot verify the handling or condition of such merchandise. We maintain a strong network of authorized retailers to ensure you are purchasing safe and complete products.

Fulfillment by a third party does not guarantee you are purchasing from one of these authorized retailers. Pricing which is inconsistent with the majority of retailers is a strong indication that the retailer is not authorized, as we have a consistent price offering across all authorized retailers.

If you are unsure of the authorization status of a retailer you are considering purchasing from, or have purchased from, you can check www.maxicosi.com/ca-en/shops.aspx; or call our Consumer Care Department at 1-800-951-4113; or text us at 1-812-652-2525.

Replacement Parts List

Chest Clip	Base
Seat Pad Set	Instructions
Crossbody Strap	Locking Clip
Harness Strap	

**If requested color is not available,
similar color will be substituted.**

**Applicable tax and shipping &
handling will also be added.**

For parts availability and questions,
please call: 1-800-951-4113 or text: 1-812-652-2525.

If you already know which parts you need,
you may complete your order with a credit card
by calling us at 1-800-951-4113.

We accept Visa or MasterCard.

Hours of Operation:

M-TH: 8:00 AM - 6:00 PM EST
FRI: 8:00 AM - 4:30 PM EST

Dorel Juvenile Group Information

Thank you for choosing this car seat, also known as an infant restraint.

The DJG family is committed to creating car seats with the most comfort and convenience available today.

Remember, parents are a child's first teachers and examples.

If you always buckle your seat belt, your child will think it is the natural thing to do.

Make it a firm rule that the vehicle does not go until everyone is buckled up.

Make no exceptions.

No one can predict if use of a car seat will prevent injury or death in a particular crash.

However, when combined with careful driving, proper use of a car seat can lower an infant's risk of injury or death in most crashes.

If you have questions or any concerns with this car seat, please contact our Consumer Care Department:

Call: 1-800-951-4113

Text: 1-812-652-2525

Website: maxicosi.com

Hours of Operation:

M-TH: 8:00 AM - 6:00 PM EST

FRI: 8:00 AM - 4:30 PM EST