

Adventure Starts Here.

ADIRONDACK COUNTER HEIGHT CHAIR

**SEAHAWK
DESIGNS**

EST. 2005

! NOTICE

- Do not overtighten hardware.
- Do not exceed the weight capacity of this item.
- Only use this item for what it is intended for, improper use will void any warranty.
- Firmly secure all bolts, screws and nuts before use.
- Reconfirm that all bolts, screws, and nuts are firmly secured every 90 days.
- Keep this furniture clear of all uncontrolled open flames or flammable/combustible materials. Exposure to fire, high heat, or embers will permanently damage the material.
- To avoid stripping and cracking of the material, DO NOT use power tools for assembly.
- Always prioritize caution and safety throughout the assembly process.

TOOLS REQUIRED

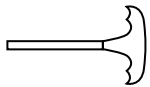

ALLEN WRENCH
(PROVIDED)

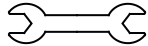

WRENCH
(PROVIDED)



330 LBS
WEIGHT
CAPACITY



SUGGESTED
2 PERSON
ASSEMBLY



ESTIMATED
ASSEMBLY
TIME: 20 MIN

1

SCREW
M6 x 40mm



1 PC

2

SCREW
M6 x 70mm



2 PCS

3

SCREW
M6 x 80mm



6 PCS

4

SCREW
M6 x 90mm



2 PCS

5

BOLT
M6 x 55mm



4 PCS

6

BOLT
M6 x 65mm

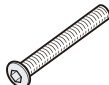

6 PCS

7

BOLT
M6 x 70mm



2 PCS

8

M6-NUT



12 PCS

9

M6-WASHER

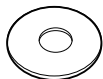

12 PCS

10

SCREW HOLE PLUG



22 PCS

A

CHAIR SEAT

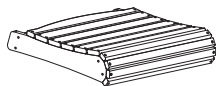

1 PC

B

CHAIR BACKREST

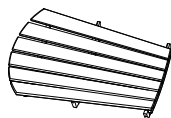

1 PC

C

LEFT FRONT LEG

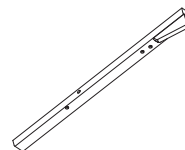

1 PC

D

RIGHT FRONT LEG

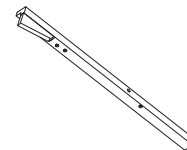

1 PC

E

LEFT REAR LEG

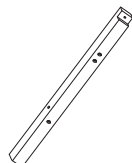

1 PC

F

RIGHT REAR LEG

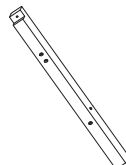

1 PC

G

LEFT ARM

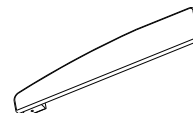

1 PC

H

RIGHT ARM

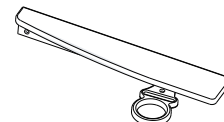

1 PC

I

FOOTREST

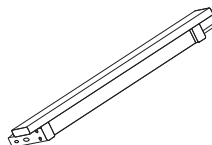

1 PC

J

CUP HOLDER

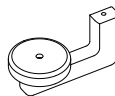

1 PC

K

SIDE RAIL



2 PCS

L

BACK RAIL

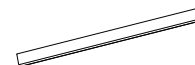

1 PC

PRODUCT ASSEMBLY - OVERALL VIEW

REF#: OP7039

Please refer back to this image during the assembly process for part placement.

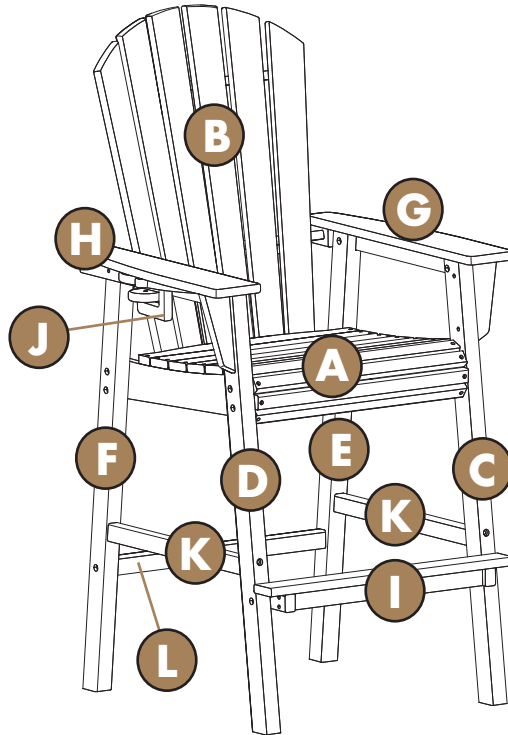

1

Step 1: Assemble the Left Legs and the Right Legs

- Remove the plastic protection tube from the pre-installed steel pins in **Part K (Side Rail)** and locate the pins to the holes in **Part E (Left Rear Leg)** and **Part C (Left Front Leg)** (see image below).
- Attach **Left Legs (Part C and Part E)** to **Part K (Side Rail)** using **2 - M6 Screw (#3)** (see image below).
- Do the same to attach **Right Legs (Part D and Part F)** to **Part K (Side Rail)** using **2 - M6 Screw (#3)**.
- Do not fully tighten the bolts yet. Tighten them to approximately 70% to allow for adjustments during final assembly.

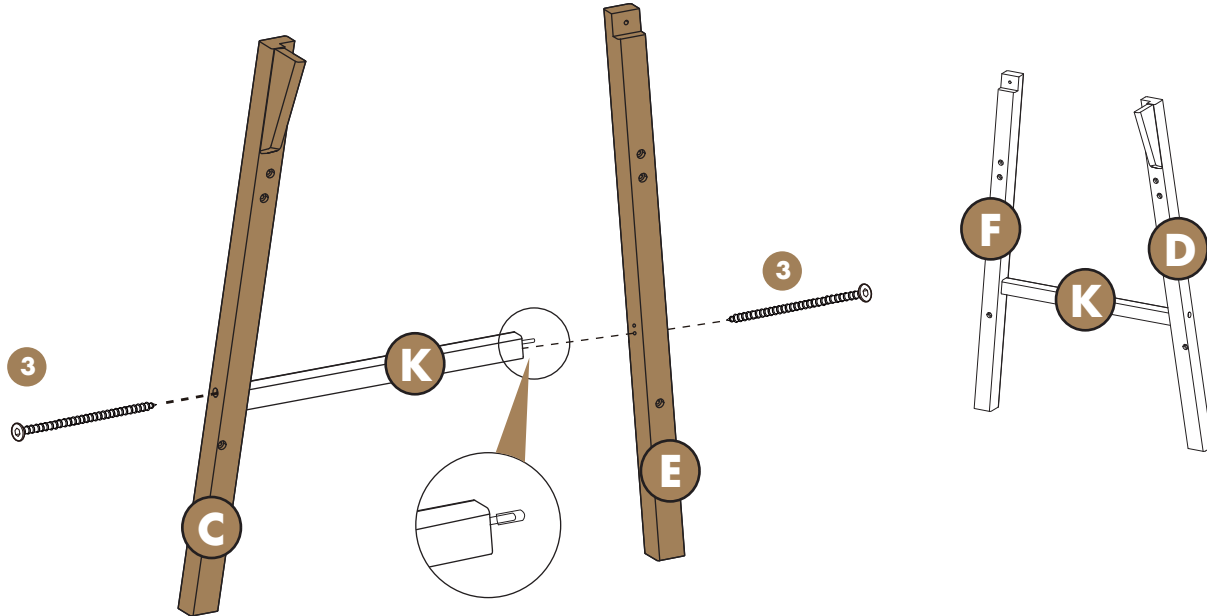

2

Step 2: Attach the Left Legs to the Chair Seat

- Place **Part A (Chair Seat)** on a flat, stable surface (see image below).
- Attach the combined **Left Leg (Part C, Part K and Part E)** to **Part A (Chair Seat)** using **3 - sets** of the **M6 Bolt (#6)**, **M6 Washer (#9)**, and **M6 Nut (#8)** (see image below).

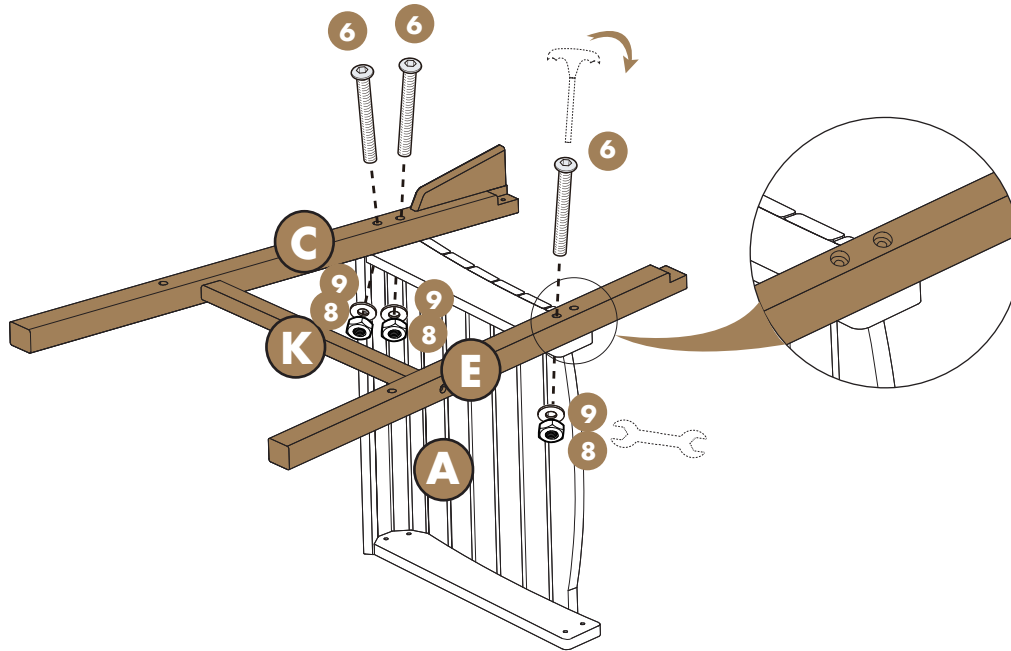

3

Step 3: Attach the Right Legs to the Chair Seat

- Mirror the previous step (Step 2) on the opposite side. Secure the combined **Right Legs (Part D, Part K and Part F)** to **Part A (Chair Seat)** using **3 - sets of the M6 Bolt (#6), M6 Washer (#9), and M6 Nut (#8)** (see image below).

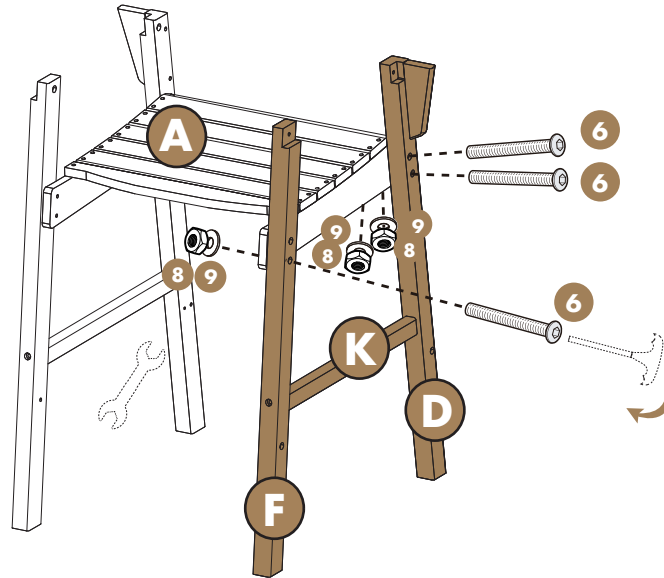

4

Step 4: Attach the Back Rail to the Rear Legs

- Attach **Part L (Back Rail)** to **Rear Legs (Part E and Part F)** using **2 - M6 Screw (#2)** (see image below).

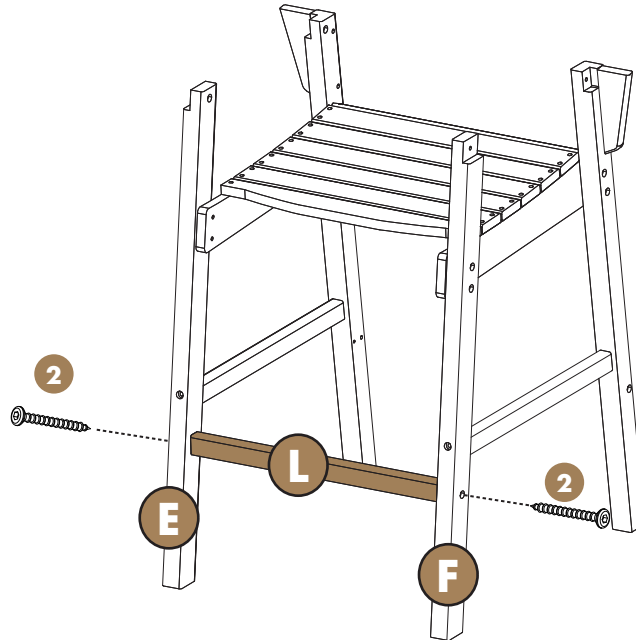

5

Step 5: Attach the Footrest to the Front Legs

- Remove the plastic protection tube from the pre-installed pins in **Part I (Footrest)** and locate the pins to the hole in **Part D (Right Front Leg)** and **Part C (Left Front Leg)** (see image below).
- Attach **Part I (Footrest)** to the legs using **2 - sets of the M6 Bolt (#7), M6 Washer (#10), and M6 Nut (#9)** (see image below).

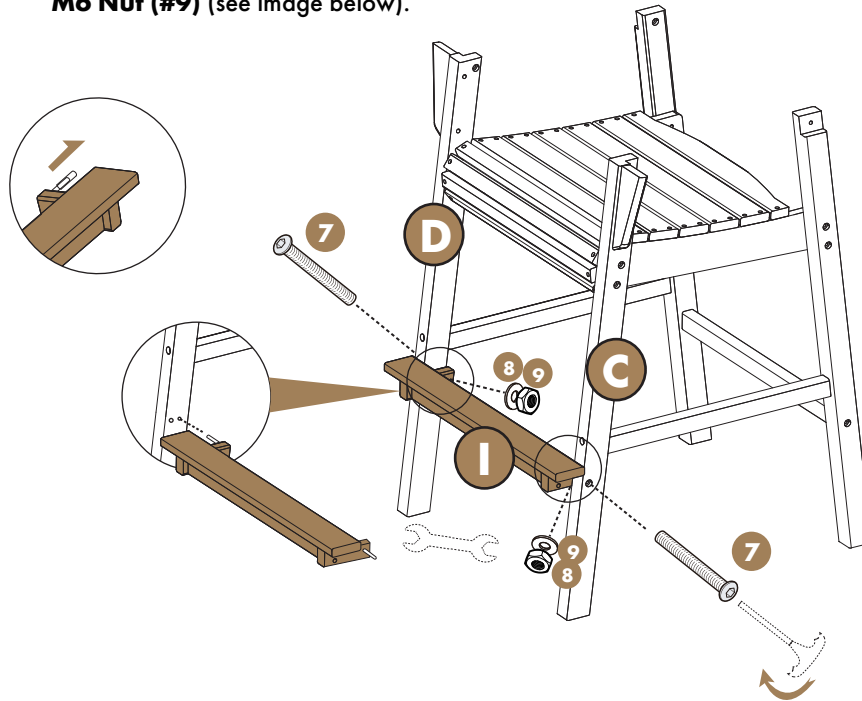

6

Step 6: Attach the Cup Holder to the Arm, and Arm to Chair

- Attach **Part J (Cup Holder)** to the bracket on the **Part H (Right Arm)** using **1 - M6 Screw (#1)** (see image below).
- Next, secure the combined **Part H (Right Arm with Cup Holder)** unit to the **Right Chair Legs (Part D, Part K and Part F)**. This requires **2 - sets of the M6 Bolt (#5), M6 Washer (#9), and M6 Nut (#8)** (see image below).

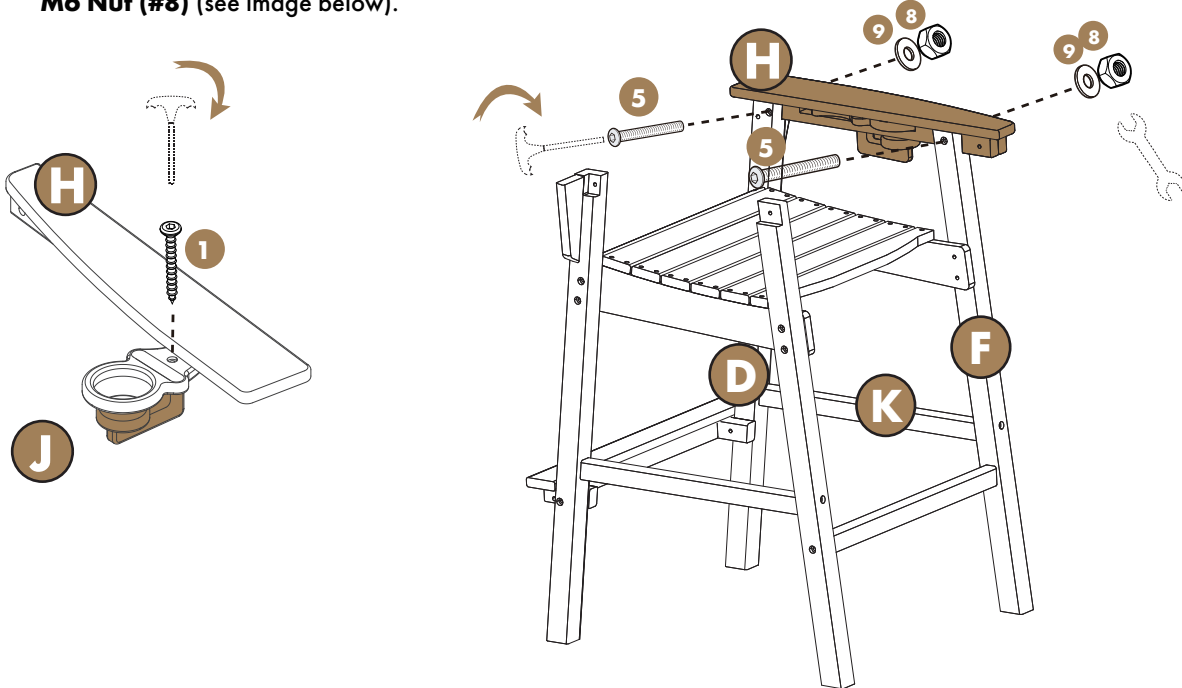

7

Step 7: Attach the Second Arm to the Chair

- Mirror the previous step (Step 6) on the opposite side. Secure **Part G (Left Arm)** to the **Left Chair Legs (Part C, Part K and Part E)**. This requires **2 - sets** of the **M6 Bolt (#5)**, **M6 Washer (#9)**, and **M6 Nut (#8)** (see image below).

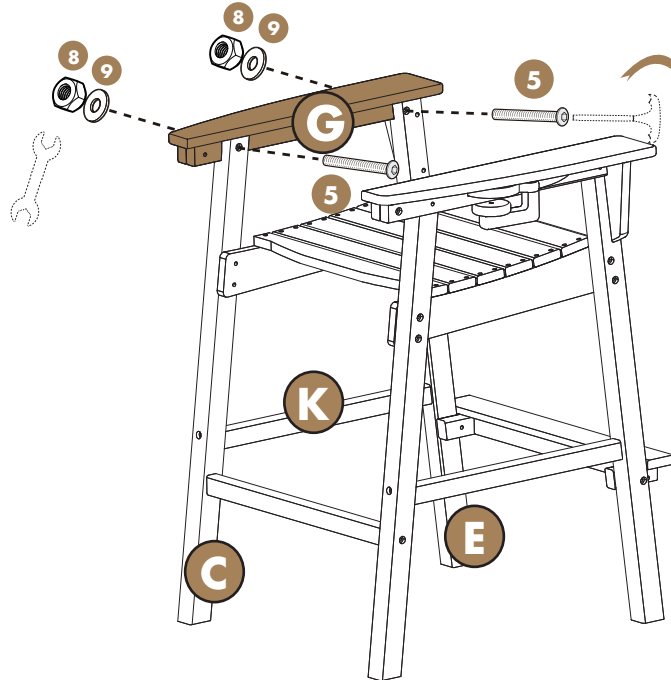

8

Step 8: Attach the Backrest to the Assembled Frame

- Attach the **Part B (Chair Backrest)** to the assembled frame. Use **2 - M6 Screw (#3)** and **2 - M6 Screw (#4)** to secure it (see image below).

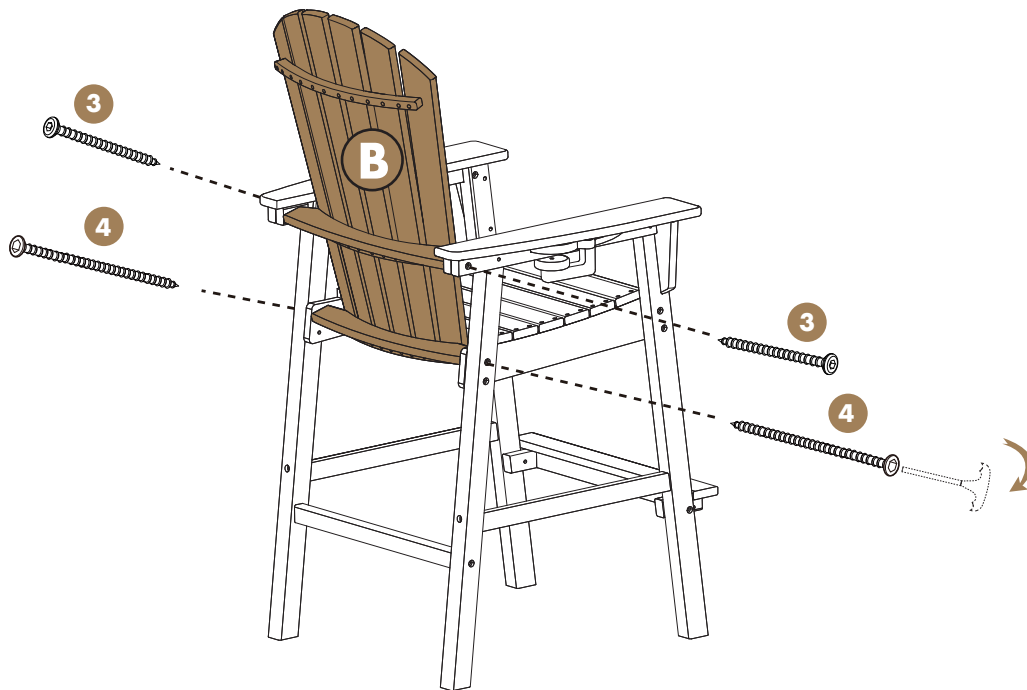

9

Step 9: Final Tightening and Stability Check

- Tighten all previously installed screws, bolts, and nuts. Check every connection to ensure the chair is steady and stable.

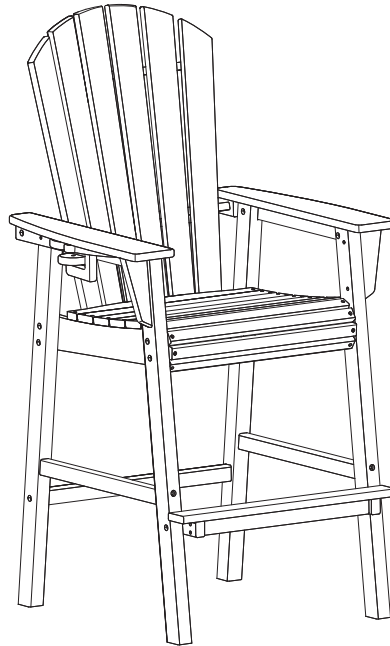

10

Step 10: Apply the Screw Hole Plugs

- Cover all exposed screw holes using **22 - Screw Hole Plug (#10)**. Insert all plugs into the exposed screw holes. Gently tap each plug into place using a rubber mallet to prevent damage. Ensure each plug is fully seated and flush with the chair surface (see image below).

ATTENTION: Do not use a metal hammer as it will damage the poly lumber.

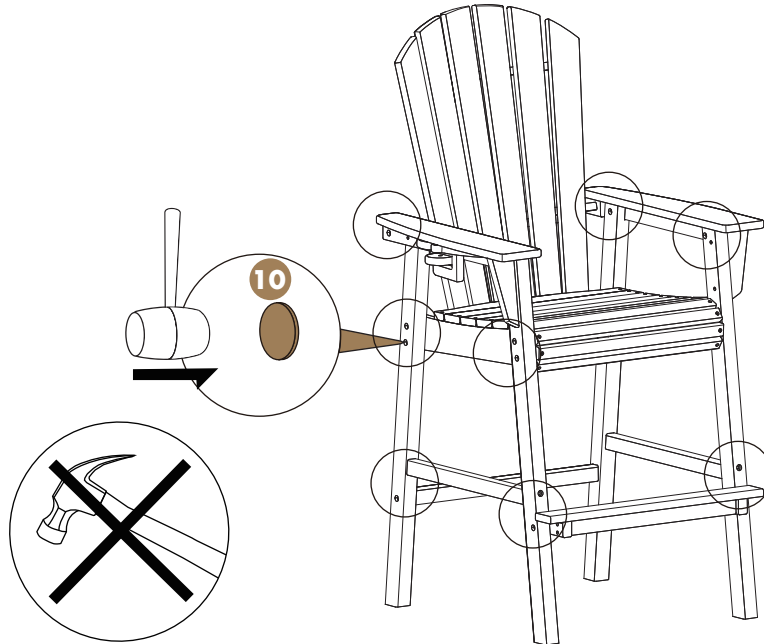

- **REGULAR CLEAN:** Mix **warm water and mild soap**. Use a **soft bristle brush** to gently scrub the surface and remove any dirt or stains.
- **QUICK CLEAN:** Simply wipe the furniture down using a damp cloth.

Tip: Cleaning your furniture regularly helps maintain its aesthetic appeal and extends its lifespan.

Enjoy!

Join our community and be the first to see what's new!

Follow us on socials:      



Quickly register your outdoor furniture purchase to activate your warranty and enjoy peace of mind with guaranteed product protection:



Have questions or need assistance? Reach out to our dedicated team at **(909) 284-1052** or email us at **cs@seahawkdesigns.com**.