

Installation Instructions for G3 720 Series Dummy Levers, and Contractor 100 Series

Option 1: Through-fixing (Recommended Option).

1. Drill one 15mm hole (using spade bit) through the door and two 6mm holes (using drill bit) through the door at required distance (backset) from door edge-refer template below.
2. Fit the stepped threaded post (1) provided to the threaded hole in the underside of the lever handle assembly (2).
3. Temporarily fit the dummy fixing plate (3) into the lever handle assembly, ensuring both the handle grub screw (4) and spindle groove (5) point to the floor. (This will allow you to identify the hole opposite the fixed stepped threaded post to which the threaded ferrule (6) will be fixed to in Step 4.)
4. Now holding only the dummy fixing plate, fix the threaded ferrule to the previously identified hole in the fixing plate using the 10mm long screw (7) provided.
5. Fit the dummy fixing plate to the door, and fit the lever handle assembly onto the spindle and nip the grub screw, ENSURING HANDLE GRUB SCREW AND GROOVE OF THE FIXING PLATE SPINDLE POINT TO THE FLOOR.
6. Fit the 25mm screw (8) through the fixing plate and into the stepped threaded post. Now fit the 30mm long special headed screw (9) through the lever handle assembly into the threaded ferrule. Loosen the grub screw and tighten both of the mounting screws, then re-tighten the grub screw.
7. Slide the rosette cover (10) over the lever (ensuring notch in rosette cover is pointing to the floor) and fix into position (refer to diagram).

Note: Notch in rosette cover should point to floor – refer diagram.

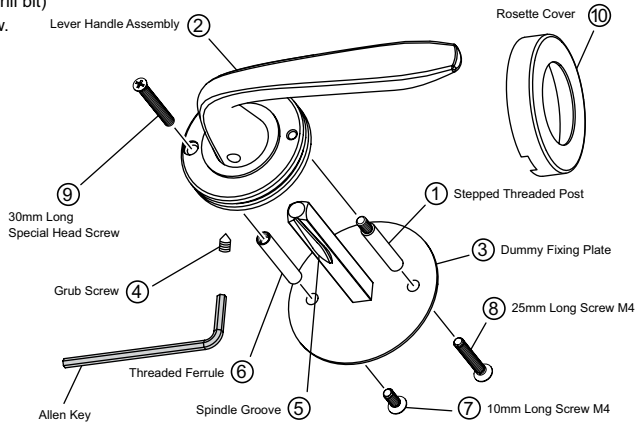

Option 2: Wood screw fixing

1. Drill one 15mm hole (using spade bit) through the door at required distance (backset) from door edge-refer template below.
2. Drill two only pilot holes for wood screws-ONLY on the side of door to which dummy fixing plate (3) will be affixed.
NOTE: DO NOT DRILL THESE TWO PILOT HOLES THROUGH THE DOOR
3. Fix the dummy fixing plate (3) to the door with the 2 wood screws (11).
4. With rosette cover (10) in place, fit the lever handle assembly (2) onto the spindle, ENSURING HANDLE GRUB SCREW AND GROOVE OF FIXING PLATE POINT TO THE FLOOR. Push lever handle assembly hard up against door prior to tightening grub screw.

Note: Notch in rosette cover should point to floor – refer diagram.

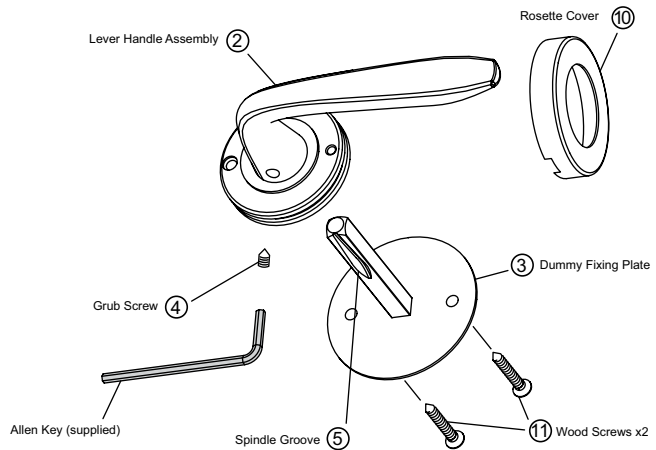

NOTE: Carefully follow these instructions when installing. Screws to be tightened to a recommended 2.5Nm torque.



FOLD HERE

FOLD HERE

Fit here on door edge

Fit here on door edge

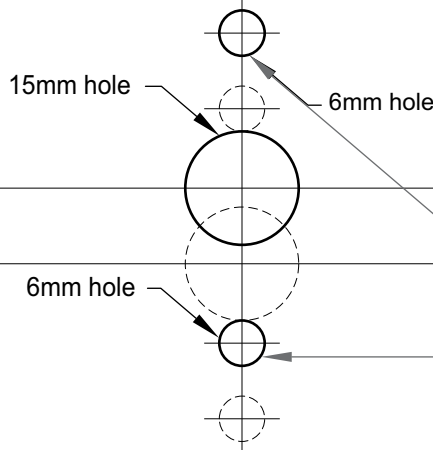

Note: Drill 2mm pilot hole only for option 2. Do not drill 6mm hole.

Installation template for dummy applications

Gainsborough

Allegion Australia
Melbourne, Australia. A.B.N. 1 J A E I A J I A F I F A
www.gainsboroughhardware.com.au