

5 SPEED BENCH DRILL PRESS WITH 4 IN. VISE

W50005



OWNER'S MANUAL SAVE THIS MANUAL

Table of Contents	
Safety Information	2
Electrical Requirements	3
Drill Press Safety	3
Accessories	4
Drill Press Assembly	4-6
Drill Press Adjustments	6
Drill Press Operation	7-8
Parts Description	8
Drill Press Components	9-11
Warranty	12

SPECIFICATIONS

Maximum HP developed	1/3
Volts	120
Hertz	60
RPM	1700
5 Speeds	760,1150,1630, 2180,3070 RPM
Chuck Size	1/2"
Spindle Travel	2"
Swing	8"
Max Distance, Spindle to Base	11-3/8"
Max Distance, Spindle to Table	7-3/4"
Height	22-1/2"
Shipping Weight	Approx. 30 lbs.
Drilling Capacity	1/2" Diameter in Steel
Toggle ON/OFF switch	With Safety Lock Key
Table Size	6-1/4" X 6-1/4"
Table swivels 360° around support column and tilts -45° to +45°	
Precision Ground Cast Iron construction equipped with lock levers.	
Column is cylindrical Ground Steel Tubing	
Base & Head are durable cast iron	



**Chuck
Safety Guard
and 2-1/2" Vise
Included**

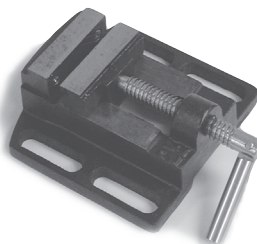

PROTECT YOUR EYES.

The operation of any power tool can result in foreign objects being thrown into the eyes which can result in severe eye damage. Always wear eye protection during power tool operation.

PLEASE WEAR



To avoid electrical shock to yourself and damage to the drill press, use proper circuit protection. The drill press is factory wired for 120V, 60 Hz operation. Connect to a 120V, 15 amp branch circuit and use a 15 amp time delay fuse or circuit breaker. The electrical circuit can not have any wire size less than #12. To avoid shock or fire, replace power cord immediately if it is damaged in any way.

PT

Performance Tool®

On occasion, after printing of our literature is completed, our manufacturers may make changes and/or modifications to merchandise which will not be reflected in this manual. Although we strive to maintain complete and accurate information, it is possible in some instances, that the product may differ slightly from printed specifications. Illustrations are intended for reference only. Actual merchandise may vary. Wilmar is not responsible for typographical errors.

SAFETY INFORMATION

Carefully read through the entire owner's manual before operating your 5 speed drill press. Keep manual with important records for safety instructions, operating procedures and warranty.



WARNING: When using electrical tools, machines or equipment, basic safety precautions should always be followed to minimize the risk of fire, electrical shock or personal injury to yourself and others.

BEFORE USING YOUR DRILL PRESS

- **READ THE ENTIRE MANUAL.**
 - **GROUND ALL TOOLS.** Any tool supplied with a 3-prong plug must be plugged into a 3-contact electrical receptacle. The 3rd prong is used to ground the tool and provide protection against accidental electrical shock. Never remove the third prong.
 - **AVOID DANGEROUS ENVIRONMENTS.** Do not use power tools near gasoline or other flammable materials, in damp or wet locations or expose them to rain. Keep work area well lit. Normal sparking of the motor or sparking from drilling metal could ignite fumes.
 - **KEEP WORK AREA CLEAN.** Messy areas and cluttered work benches invite personal injury and or property damage.
 - **KEEP CHILDREN AND VISITORS AWAY.** All children should be kept away from the work area. Maintain a safe distance for any person near the work area. Adults near the work area must wear safety glasses. DO NOT let children handle the power tool or extension cord.
 - **DRUGS, ALCOHOL, MEDICATION.** Operating any tool or equipment under the influence of drugs, alcohol, and / or medication can cause personal injury to yourself and others.
 - **WEAR PROPER APPAREL.** Remove your jewelry before using tool. DO NOT wear loose clothing, neckties, rings, bracelets, or other jewelry which may get caught in moving parts. Non skid footwear and non-electrically conductive gloves are highly suggested while working. Wear protective hair covering to contain long hair.
 - **PROTECT YOUR EYES.**

The operation of any power tool can result in foreign objects being thrown into the eyes which can result in severe eye damage. Always wear eye protection during power tool operation. Eyeglasses are not always safety glasses.
 - **BE RESPONSIBLE FOR YOUR HEARING AND BREATHING.**

Wear hearing protection during extended periods of operation. Protect your lungs by wearing a clean face or dust mask.
 - **GUARD AGAINST ELECTRICAL SHOCK.** Avoid body contact with grounded surfaces such as pipes, radiators, ovens, stoves and refrigerator enclosures.
 - **USE THE RIGHT TOOL.** Use tools properly and for its intended task. DO NOT force a small tool to do the job of a heavy duty tool. Using the right tool to do the right job will do the job intended and safer.
 - **CHECK DAMAGED PARTS.** Before use of a tool, a guard or other part that is damaged, it should be carefully checked to assure that it will operate properly and perform its intended function. Check for misalignment or binding of moving parts, breakage of parts, mounting, or any other conditions that may affect its operation. A guard or other part that is damaged should be properly replaced.
 - **KEEP PROTECTIVE GUARDS IN PLACE AND IN PROPER WORKING CONDITION.**
 - **AVOID UNINTENTIONAL STARTING.** Be sure that your power tool is in the "OFF" position before plugging it into a power cord or electrical receptacle.
 - **STORE ALL MAINTENANCE TOOLS** away from the immediate area prior to turning "ON" your drill press.
 - **DO NOT OVERREACH.** Proper footing and balance is a must at all times while using the tool. Unstable support may lead to personal injury.
 - **DO NOT STAND ON THE TOOL.** Serious injury could result if the tool tips over or you accidentally contact the tool.
 - **NEVER LEAVE TOOL RUNNING UNATTENDED.** ALWAYS turn the power to the "OFF" position and do not leave the tool until it comes to a complete stop.
 - **USE RECOMMENDED ACCESSORIES.** Consult the owners manual for recommended accessories. The use of improper accessories may cause risk of injury to yourself and others.
 - **ALWAYS MAKE SURE THE TOOL IS IN THE "OFF" POSITION AND UNPLUGGED** from the electrical receptacle when making adjustments, changing parts or performing any maintenance.
 - **SECURE WORK.** When possible the use of clamps or a holding device is much safer than holding the workpiece with your hands.
 - **MAINTAIN TOOLS WITH CARE.** Tools function better and safer when kept clean and in good working condition. Keeping the tool clean, dry, free of grime will add to its life and performance.
 - **CHILDPROOF THE WORKSHOP.** The use of master switches and padlocks is highly suggested. Remove starter keys.
 - **EXTENSION CORD GUIDELINES.** Use only 3-wire extension cords that have 3-prong grounding type plugs and 3 prong receptacles that accept the tool's plug. Only UL listed extension cords should be used with this product. Improper use of extension cords may cause inefficient operation of your tool which can result in overheating. Be sure your extension cord is rated to allow sufficient flow to the motor. Refer to guide below for minimum gauge for extension cords.
- | EXTENSION CORD LENGTH | WIRE SIZE (A.W.G.) |
|-----------------------|--------------------|
| Up to 25 feet | 14 |
| 26 to 50 feet | 12 |
| 51 to 100 feet | DO NOT USE |
- The use of an extension cord heavy enough to carry the current a tool will draw is very important. Especially when the power source is of great distance. An extension cord that is insufficient will cause a drop in line voltage, resulting in power loss and causing the motor to overheat.
- When the project requires you to be outdoors, use an extension cord designed for outdoor use. The letters "WA" are indicated on the jacket of the cord.

ELECTRICAL REQUIREMENTS

CONNECTING TOOL TO POWER SOURCE OUTLET

This machine source must be grounded while in use to protect the operator from electric shock. In the event of a malfunction or breakdown, grounding provides a path of least resistance for electric current to reduce the risk of electric shock. This tool is equipped with an electric cord having an equipment grounding conductor and a grounding plug. The plug must be plugged into a matching outlet that is properly installed and grounded in accordance with all local codes and ordinances.

Improper connection of the equipment grounding conductor can result in a risk of electric shock. The conductor with insulation having an outer surface that is green (with or without yellow stripes) is the equipment grounding conductor. If repair or replacement of the electric cord or plug is necessary, **DO NOT** connect the equipment - grounding conductor to a live terminal. **DO NOT MODIFY THE PLUG PROVIDED.** If it will not fit the receptacle, have the proper receptacle installed by a qualified electrician. Check with a qualified electrician or service personnel if the grounding instructions are not completely understood, or if in doubt as to if the tool is properly grounded.

Fig. A

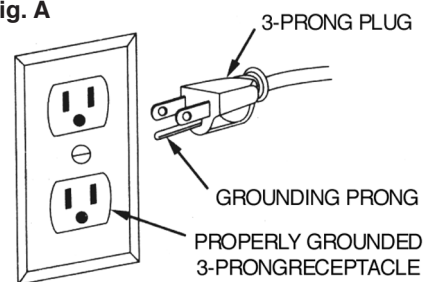

This tool is intended for use on a circuit that has an outlet that looks like the one illustrated in Figure A. The tool has a grounding plug that looks like the one also shown in Figure A. **DO NOT** modify the plug provided if it will not fit the outlet. Have the proper outlet installed by a professional electrician.



WARNING: If not properly grounded, this power tool can incur the potential hazard of electrical shock particularly when used in damp locations or in proximity to plumbing. If an electrical shock occurs, there is the potential of a secondary hazard such as your hands contacting the drill bit.

DRILL PRESS SAFETY INSTRUCTIONS



WARNING: For your own safety, do not try to use your drill press or plug it in until it is completely assembled and installed according to the instructions, and until you have read and understood this instruction manual:

- 1. THE DRILL PRESS MUST BE BOLTED** securely to a workbench. If the possibility of the drill press moving during certain projects, secure the workbench to the floor properly and safely.
- 2. THE DRILL PRESS** is designed for use indoors only.
- 3. ALWAYS KEEP YOUR HANDS** out of the path of a drill bit. A sudden slip, caused by an awkward hand position could cause your hand to move into the drill bit. This may result in serious injury.
- 4. DO NOT** drill materials too small to be held securely and safely.
- 5. PRIOR TO STARTING** the project, jiggle the motor switch to make certain the drill bit does not vibrate or wobble.
- 6. ALWAYS** hold the project piece firmly against the table so it will not twist or rock. **DO NOT** attempt to do any project freehand.
- 7. BE CERTAIN** there are no nails, screws or any foreign objects in the project piece to be drilled.
- 8. DO NOT USE** shaper cutters, router bits, rotary planers, circle (fly) cutters, or wire wheels on this drill press.
- 9. DO NOT** use a drill bit that exceeds 7" (175mm) in length or extends 6" (150mm) below the chuck jaws. It is possible, the drill bit can break or bend outwards. This may result in personal injury.
- 10. BE SURE** to fasten the drill press vise securely to the table.
- 11. SECURE PROJECT.** It is much safer to use clamps or the drill press vise to hold your project allowing the use of both hands to operate the drill press.
- 12. NEVER** turn your drill press on before cleaning the table of all debris and objects.
- 13. MAKE SURE** all locks and clamps are securely tightened before beginning project.
- 14. BRACE OR CLAMP PROJECT** against the left side of the column to prevent rotation. If the table is tilted or the project is too short, clamp the project securely to the table.
- 15. SECURELY LOCK** the head and table support to the column, and the table to the table support before operating the drill press.
- 16. DO NOT** set up work on the drill press table while the drill press is "ON".
- 17. BE SMART.** If your project requires the drilling of large holes, clamp the project to the table or use the drill press vise. It is possible, if you do not secure the project, the bit may grab, and the project may spin at high speed. **DO NOT** use multi-part hole cutters or fly cutters, they can become unbalanced in use or come apart.
- 18. BE SURE** the spindle has completely stopped before touching the project.
- 19. ACCIDENTAL STARTING.** Always turn the switch "OFF" and unplug the drill press before removing or installing any attachment or accessory, or performing any adjustment.
- 20. WARNING.** Always lock the switch "OFF" when the drill press is not in use. Remove and keep the key in a safe place.
- 21. RECOMMENDED SPEED.** SEE INSTRUCTIONS that come with your project (accessory and / or material) for the recommended drill press speed.
- 22. ALWAYS** use the self-ejecting style chuck key as included with the drill press.
- 23. THE SPINDLE MUST REACH FULL SPEED** before starting the drill. If the drill press vibrates excessively, or makes unfamiliar sounds, turn "OFF" the drill press, and unplug immediately. **DO NOT** use the drill press until the problem is resolved.
- 24. KEEP GUARDS** in place and in working order.

AVAILABLE ACCESSORIES

ON/OFF Toggle Switch	W50030
Drill Chuck	W50031
Chuck Guard	W50032
Chuck Key	W50033

DRILL PRESS ASSEMBLY

LOOSE PARTS CONTENTS:

Spindle box assembly	1 each
Base	1 each
Handle bar	3 each
Drill chuck 1/2"	1 each
Hex socket screws 4mm	2 each
Table assembly	1 each
Column assembly	1 each
Bolt - M8 X 20	3 each

The following tools (not included) are needed to assemble and align:

Adjustable Wrench, Hammer and block of wood,
Combination square, Screwdrivers, 4mm Hex Key

WARNING: If any parts are missing or damaged at time of purchase DO NOT operate this unit until missing and / or damaged parts have been replaced. Failure to do so could result in possible serious injury. If parts are missing and / or damaged at time of purchase, contact customer service at 800.426.1262.

DO NOT begin assembly of your drill press until you are certain the tool is NOT plugged in.

DO NOT begin assembly until you are certain the drill press is in the "OFF" position.

1. Mount drill press on a firm level surface where there is plenty of room for handling and properly supporting the project.
2. Avoid a dangerous environment. Use the drill press in a dry, indoor place protected from the rain. Keep work area well lit.
3. Disconnect tools before servicing or when changing accessories such as drill bits.
4. Keep guards in place and in working order. To avoid accidental starting, make sure the power switch is in the "OFF" position before plugging in.
5. Use recommended accessories. Consult the owners manual for recommended accessories. The use of improper accessories may cause risk of injury to yourself and others.

WARNING: Some dust created by drilling and other construction activities contains chemicals known to cause cancer, birth defects or other reproductive harm. Some examples of these chemicals are: LEAD from lead based paint, CRYSTALLINE SILICA from bricks and cement and other masonry products, ARSENIC and CHROMIUM from chemically treated lumber. Your risk from these exposures varies, depending on how often you do this type of work. To reduce your exposure to these chemicals: work in a well ventilated area, and work with approved safety equipment, such as those dust masks that are especially designed to filter out microscopic particles. **Know your power tool. Read the OWNERS MANUAL carefully. Learn the tools applications and limitations, as well as the specific potential hazards specific to it.**

BASE/COLUMN

1. Set the base (1) on the floor.
2. Place the column (2) on the base, align the holes in the column support with the base holes.
3. Install a bolt (3) in each column support hole, and tighten with a wrench.

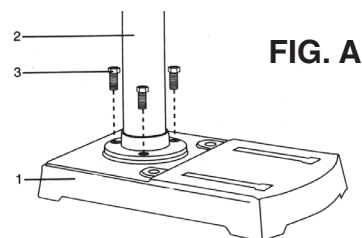

FIG. A

TABLE

1. Slide table assembly (1) down the column (2), until it rests on the base.
2. Install the lock handle (3) in the threaded hole.
3. Slide the table up the column to working height and hand tighten the lock handle to secure the table in place.

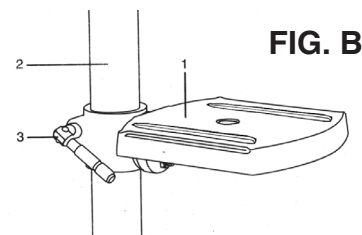

FIG. B

HEAD/MOTOR ASSEMBLY

CAUTION: The head/motor assembly (1) is heavy. Lift carefully.

1. Lift above the column (2), slide down the column as far as it will go.
2. Line the head up with the base.
3. Tighten the two locking screws (3) with a 4mm hex key.

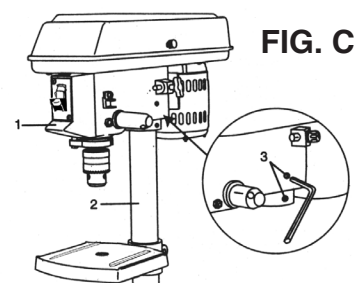

FIG. C

FEED ASSEMBLY

1. Thread the feed handles (1) into the holes on the feed hub (2).
2. Hand tighten.

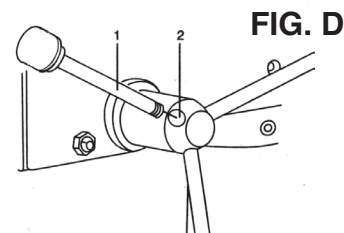

FIG. D

DRILL PRESS ASSEMBLY CONTINUED



WARNING: Be sure the switch is "OFF", and the drill press is disconnected from the power source prior to installing, removing or adjusting the chuck.

CHUCK GUARD

The telescopic chuck guard is partially assembled onto the machine.

1. Remove three cross head screws (1) just below the hinge on the collar.
2. Position the transparent plastic shield (3) into the collar and secure in place with three small cross head screws.
3. Loosen wing nuts (4) to adjust guard height.
4. Pull bottom of guard towards front of drill press and up to expose spindle for chuck installation and changing bits.

DO NOT adjust chuck guard or leave in the open position while drill is in operation or spindle is turning.

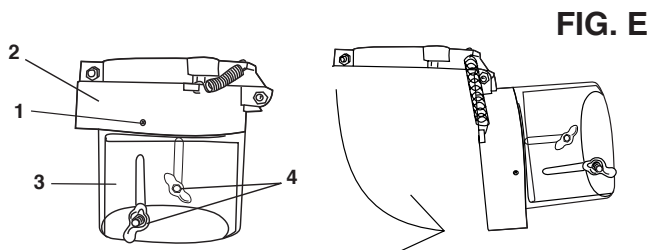

CHUCK

1. Inspect and clean the hole in the chuck (1) and the spindle (2).
2. Remove all grease, coatings, and particles from the chuck and spindle surfaces with a clean cloth.
3. Open the chuck jaws (3), by turning the chuck barrel clockwise, and make sure the jaws are completely recessed inside the chuck.
4. Seat the chuck (1) (FIG. F) onto the spindle by placing a block of wood under the chuck, and tapping the wood with a hammer, or tap the chuck with a rubber mallet or plastic-tipped hammer.

DO NOT TAP THE CHUCK WITH A METAL HAMMER.

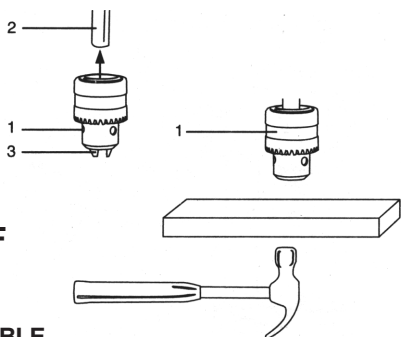

FIG. F

TO TILT THE TABLE

NOTE: The table is not pictured in FIG G for illustration purposes only.

1. Loosen the bevel lock (1) with a 3/4" wrench.
2. Tilt the table to the desired angle, using the bevel scale (2) as a basic guide.
3. Tighten the bevel lock.
4. To return the table to its original position, loosen the bevel lock bolt (1). Realign the bevel scale to 0° setting.
5. Tighten the bevel lock with a 3/4" wrench.

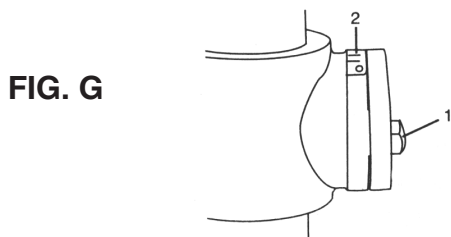

FIG. G

MOUNTING THE DRILL PRESS

Your drill press must be securely fastened by the two base holes to a stand or workbench with heavy-duty fastener (not included). This will prevent the drill press from tipping over, sliding, or moving during operation.

IMPORTANT: If the stand or workbench has a tendency to move during operation, fasten securely to the floor. (Hardware not included.)

1. Drill press base
2. Bolt
3. Flat washer
4. Rubber washer
5. Work surface
6. Flat washer
7. Lock washer
8. Hex nut
9. Jam nut

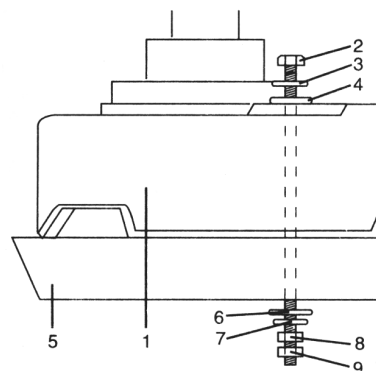

FIG. H

SPINDLE SPEEDS

This drill offers 5 spindle speeds from 760 to 3070 R.P.M. The highest speed is obtained when the belt is positioned on the largest motor pulley step and the smallest spindle pulley step.



WARNING: Be sure the switch is "OFF", and the drill press is disconnected from the power source prior to installing, removing or adjusting the chuck.

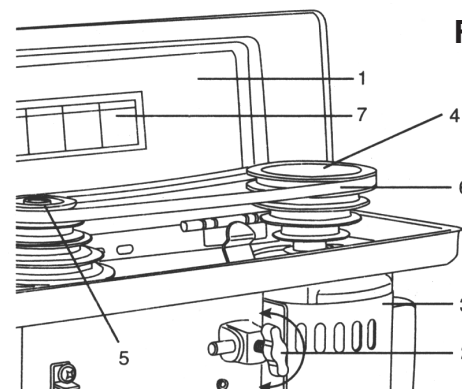

FIG. I

TO ADJUST THE TENSION BELT

1. Open the belt housing cover.(1)
 2. Turn the belt tension knob (2) to loosen the motor tension spring.
 3. Pull the motor (3) toward the front of the drill press.
 4. Hold the motor in position, and set the belt (6) on the desired steps of the motor (4) and spindle (5) pulleys.
- NOTE:** Refer to the chart (7) located under the pulley cover for set-up pulley speeds.
5. Pivot the motor (3) away from the drill press head to increase the belt tension and tighten the tension knob (2).
 6. The belt (6) should be tight enough to prevent slippage. Correct tension is set if the belt flexes about 1/2" when thumb pressure is applied at the midpoint of the belt between the pulleys.

Spindle		Motor
3070		
2180		
1630		
1150		
760		

FIG. J

DRILL PRESS ASSEMBLY CONTINUED

TO SQUARE THE TABLE TO THE HEAD

1. Insert a 3" drill bit (1) into the chuck (2), and tighten by turning the chuck barrel counterclockwise.
2. Place a combination square (4) on the table (3) as shown. The drill bit should be parallel to the straight edge of the square.
3. If an adjustment is needed, loosen the bevel lock (5) with a wrench.
4. Square the table to the bit by turning the table.
5. Tighten the bevel lock when square.

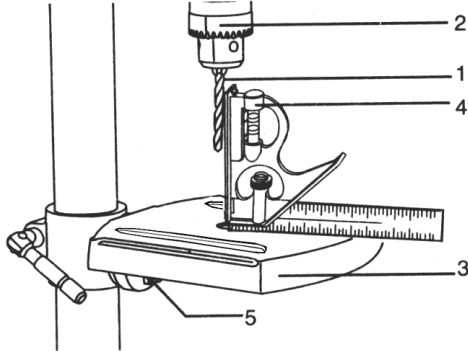

FIG. K

TO MOVE THE TABLE

1. Raise or lower the table (1) by loosening the support lock handle (2).
2. Move the table to the desired position and tighten the support lock handle.

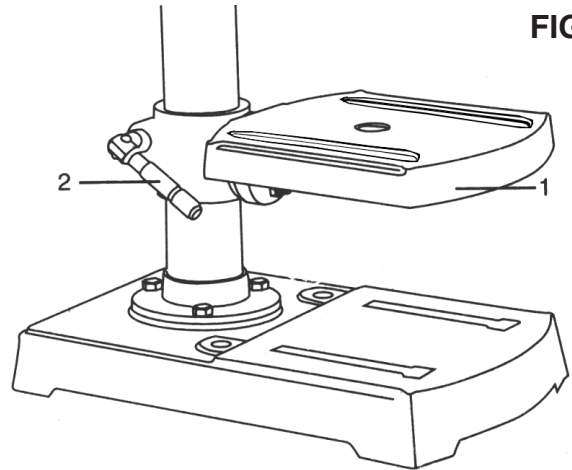

FIG. L

ADJUSTMENTS

NOTE: All necessary adjustments for the proper functioning of the drill press have been made at the factory. Please **DO NOT** modify them. Readjustments may be necessary due to normal wear and tear of the drill press.

RETURN SPRING ADJUSTMENT

It may be necessary to adjust the tension of the return spring if the quill returns too rapidly or too slowly.

1. Lower the table for additional clearance.
2. Work from the left side of the drill press.
3. Move the stop nuts (1) down to the lowest position and tighten to prevent the quill from dropping while tensioning the spring.
4. Place a screwdriver in the front notch (2) of the spring housing (3), and hold it in place. Loosen the jam nut (outer) nut (4). Remove the jam nut.
5. With the screwdriver remaining in the front notch, loosen the inner nut (5) until the notch (7) disengages from the boss (6).

DO NOT REMOVE THIS NUT.

6. Carefully move the screwdriver upward or counterclockwise, engaging the next notch in the spring housing.

DO NOT REMOVE THE SCREWDRIVER.

7. Tighten the nut (5) with the wrench only enough to engage the boss (6). **DO NOT OVERTIGHTEN** as this will restrict movement.
8. Move the stop nuts (1) and depth pointer to the upper-most position and check the tension while turning the feed handles.
9. If there is enough tension on the spring, repeat steps 3 - 8, moving only one notch each time. Proper tension is achieved when the quill returns gently to the full up position when released.
10. When there is enough tension, replace the jam nut (4) and tighten the inner nut (5), but **DO NOT** overtighten.
11. Rotate the handle to check the quill for unrestricted movement. If the movement is too tight, loosen the jam nut (4) and slightly loosen the inner nut (5). Retighten the jam nut.

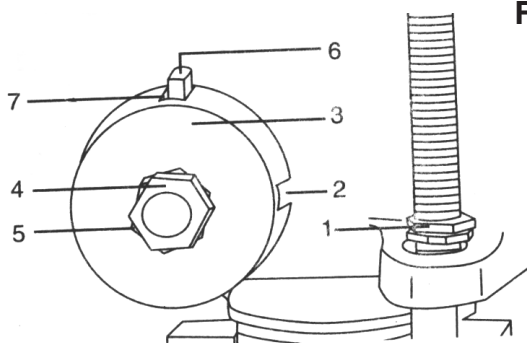

FIG. M



WARNING: For your own safety, turn switch "OFF" and remove plug from power source outlet before adjusting and maintaining your bench drill. If power cord is worn, cut, or damaged in any way, have it replaced immediately.

ANGULAR PLAY OF THE SPINDLE

Move the spindle to the lowest downward position, take it in your hands, Now try to make the spindle revolve about its axis. If there is too much play, proceed as follows:

1. Loosen the lock nut (1).
2. Turn the screw (2) clockwise to eliminate the play but without obstructing the upward and downward motion of the spindle (a little bit of play is normal).
3. Tighten the lock nut (1).

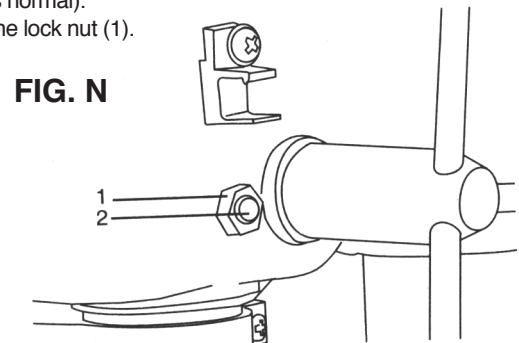

FIG. N

INSTALLING DRILL BITS

1. Open the chuck jaws by hand, turning the barrel of the chuck (1) clockwise.
2. Insert a drill bit into the chuck far enough to obtain maximum gripping of the chuck jaws (2).
3. Make sure that the drill bit is centered correctly between the chuck jaws before final tightening of the chuck.
4. Turning the chuck barrel counterclockwise, hand tighten the drill chuck sufficiently so the drill bit does not slip while drilling.

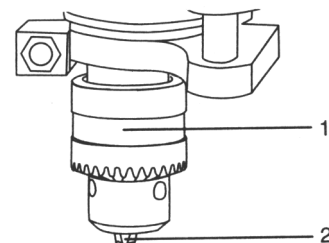

FIG. O

OPERATION

ON/OFF SWITCH

The "ON/OFF" switch has a removable, yellow plastic key. The key should always be removed and safely stored when not in operation.

1. To turn the drill press "ON", insert key (1) into the slot of the switch (2), and move the switch upward to the "ON" position.
2. To turn the drill press "OFF", move the switch downward.
3. To lock the switch in the "OFF" position, grasp the end, or yellow part, of the switch toggle, and pull it out, store in a safe place
4. With the switch key removed, the switch will not operate.
5. If the switch key is removed while the drill press is running, it can be turned "OFF", but cannot be restarted without inserting the switch key.



WARNING: Always lock the switch "OFF" when the drill press is not in use. Remove the key and keep it in a safe place. In the event of a power failure, blown fuse, or tripped circuit breaker, turn the switch "OFF" and remove the key, preventing an accidental startup when the power comes on.

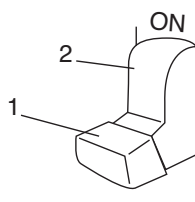

FIG. P

DRILLING A HOLE

Using a center punch or a sharp nail, mark the project where you want the hole. Before turning the switch "ON", bring the drill bit down to the project, lining up with the hole location. Turn the switch "ON" and pull down on the feed handles with only enough effort to allow the drill to cut. FEEDING TOO SLOWLY might cause the drill bit to turn. FEEDING TOO RAPIDLY might stop the motor, cause the belt or drill to slip, tear the project loose, or break the drill bit. It may be necessary to lubricate the tip of the drill bit while drilling metal. This will prevent overheating.

POSITIONING THE TABLE AND PROJECT

Always put a piece of wood or backup material (1) on the table underneath the project (2). This will prevent splintering on the underside of the project as the drill bit breaks through. To keep the project from spinning out of control, one end of it must touch the left side, (3) of the column (4) as illustrated.

FIG. Q

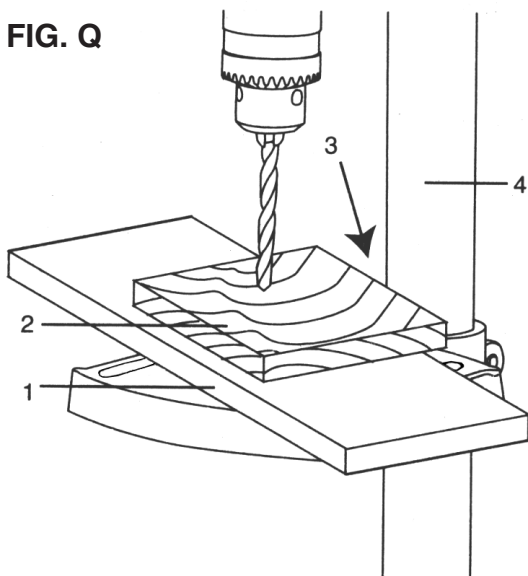

DRILLING TO A SPECIFIC DEPTH

Drilling a blind hole (not all the way through the project) to a given depth can be done two ways. (See Figures R & S)

PROJECT METHOD

1. MARK the depth of the hole on the side of the project (1).
2. WITH THE SWITCH "OFF", bring the drill bit (2) down until the tip is even with the mark.
3. Hold the feed handle at this position,
4. Spin the lower nut (3) down to contact the depth stop lug (6) on the head.
5. Spin the upper nut (5) down and tighten against the lower nut (3).
6. The drill bit will now stop after traveling the distance marked on the project.

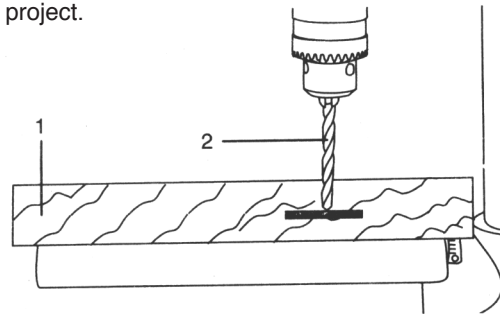

FIG. R

DEPTH SCALE METHOD (FIG.S)

NOTE: For this method, with the spindle in the up position, the drill bit tip (2) slightly touches the top of the project (1).

1. WITH THE SWITCH "OFF", turn the feed handle until the pointer (7) points to the desired depth on the depth scale (4). Hold the feed handles in that position.
2. Spin the lower nut (3) down to contact the depth stop lug (6) on the head.
3. Spin the upper stop nut (5) against the lower stop nut and tighten.
4. The downward progress of the chuck and drill bit will now stop after traveling the distance selected on the depth scale.

FIG. S

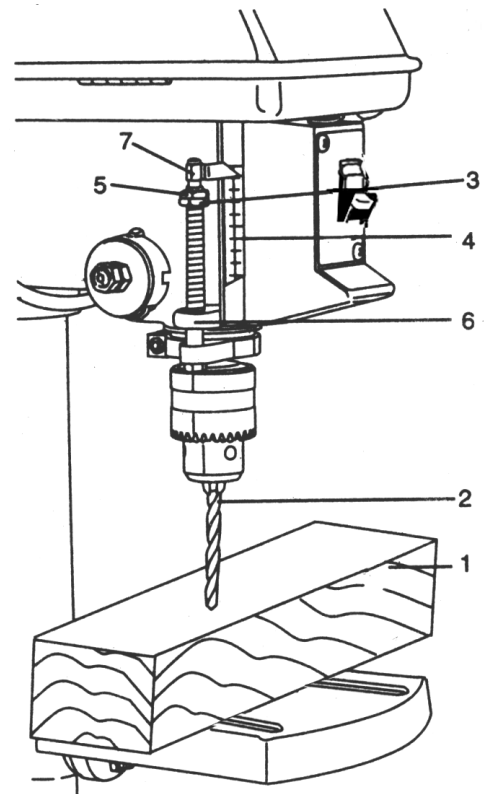

OPERATION CONTINUED

NOTE: It is suggested to use scrap material to get the feel of the drill press before attempting regular work.

DRILLING SPEEDS

DRILLING SPEED FACTORS TO CONSIDER: Type of material, hole size, type of drill bit or cutter, desired cut quality. Remember, the smaller the drill bit, the greater the required speed. When drilling soft materials, the speed required is greater than that required for hard materials.

WOOD WORKING

To drill completely through the project, line the table up so the bit will enter the center hole. Feed slowly when the bit is about to cut through the wood to prevent splintering. Use a scrap piece of wood for a base block under the work; it will help to reduce splintering and protect the point of the bit. **DO NOT** use auger bits. They have a tendency to turn so fast that the project is lifted off the table.

METAL WORKING

A metal workpiece should be clamped down securely. **NEVER** hold it with your bare hands; the drill bit may seize the project and cause serious personal injury. The drill bit may also break if the metal project hits the column. Clamp work firmly; any tilting, twisting, or shifting results not only in a rough hole, but increases the potential of drill bit breakage. If the metal piece is flat, place a piece of wood under it to prevent it from turning. If the piece is an irregular shape and cannot be laid flat on the table, it should be securely blocked and clamped.

FEEDING

Pull down on the feed handles with enough force to allow the drill to cut. Feeding too rapidly might stall the motor, cause the belt to slip, damage the workpiece, or break the drill bit. Feeding too slowly will cause the drill bit to heat up and burn the workpiece.

WARNING: To prevent the project or backup material from being torn from your hands while drilling, you **MUST** position the project against the **LEFT** side of the column. If the project or the backup material is not long enough to reach the column, clamp them to the table or use the drill press vise. Failure to secure the project could result in personal injury.

PARTS DESCRIPTION AND DEFINITION

BASE - Supports drill press. For additional stability, holes are provided in base to bolt drill press to floor. (See "Specific Safety Instructions for Drill Presses".)

BACKUP MATERIAL - A piece of scrap wood placed between the project and table. The backup board prevents wood in the workpiece from splintering when the drill passes through the backside of the project. It also prevents drilling into the table top.

BELT GUARD ASSEMBLY - Covers pulley and belt during operation of the drill press.

BELT TENSION - Refer to the "Assembly" section, "Installing and Tensioning Belt."

BELT TENSION LOCK KNOB - Tightening the knob locks the motor bracket support maintaining correct belt distance and tension.

BEVEL SCALE - Shows degree of table tilt for bevel operations. Scale is mounted to side of arm

CHUCK - Holds drill bit or other recommended accessory to perform desired operations.

CHUCK KEY - A self-ejecting chuck key that will pop out of the chuck when you let go of it. This action is designed to help prevent throwing of the chuck key from the chuck when the power is turned "ON". **DO NOT** use any other key as a substitute: order a new one if damaged or lost.

COLUMN - Connects head, table, and base on a one piece tube for easy alignment and movement.

COLUMN SUPPORT - Supports column and provides mounting holes for column to base.

DEPTH SCALE - Indicates depth of hole being drilled.

DEPTH SCALE POINTER - Indicates the drilling depth by pointing to the depth scale.

DEPTH SCALE LOCK - Locks the depth scale to selected depth.

DRILL BIT - The cutting tool used in the drill press to make holes in a project.

DRILL ON/OFF SWITCH - This drill features a locking ON/OFF switch that is intended to help prevent use by children and others.

DRILLING SPEED - Changed by placing the belt in any of the steps grooves in the pulleys. See Spindle Speed inside belt guard.

FEED HANDLE - Moves the chuck up or down. One or two of the handles may be removed if necessary whenever the project is such unusual shape that it interferes with the handles.

HEAD LOCKS - Locks the head to the column. **ALWAYS** lock head into place while operating the drill press.

PROJECT - Material being drilled.

REVOLUTION PER MINUTE (RPM) - The number of turns completed by a spinning object in one minute.

SPINDLE SPEED - The RPM of the spindle.

SPRING CAP - Adjusts quill spring tension.

SUPPORT LOCK - Tightening locks table support to column. **ALWAYS** have it locked in place while operating the drill press.

TABLE - Provides working surface to support workpiece.

TABLE BEVEL LOCK - Locks the table in any position from 0° - 45°.

TABLE LOCK - Locks the table after it is rotated to various positions.

TABLE SUPPORT - Rides on column to support table arm and table. 8

DRILL PRESS COMPONENTS



WARNING: If any parts are missing do not operate this machine until the missing parts are replaced. Failure to do so could result in possible serious injury. **Know your drill press. Read the OWNERS MANUAL carefully. Learn the tools applications and limitations, as well as the specific potential hazards specific to it.**



WARNING: MAINTAIN DRILL PRESS WITH CARE. Keep tools sharp and clean for best and safest results. To avoid fire or toxic reaction, never use gasoline, naphtha, acetone, lacquer thinner or similar highly volatile solvents to clean the drill press.

To protect the drill press from moisture, a protective coating has been applied to the machined surfaces. Remove this coating with a soft cloth moistened with or WD-40

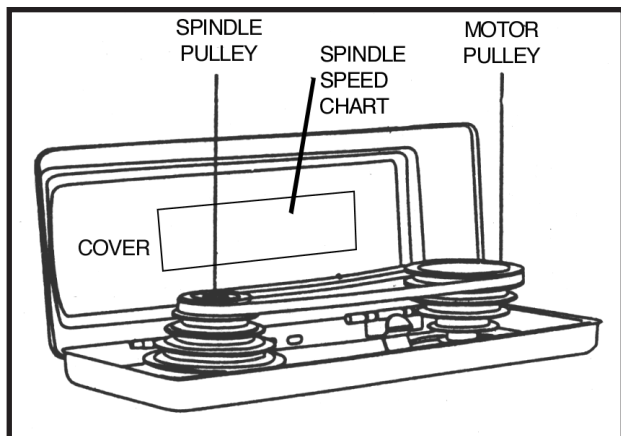

See "ASSEMBLY & ADJUSTMENTS" for spindle speed options

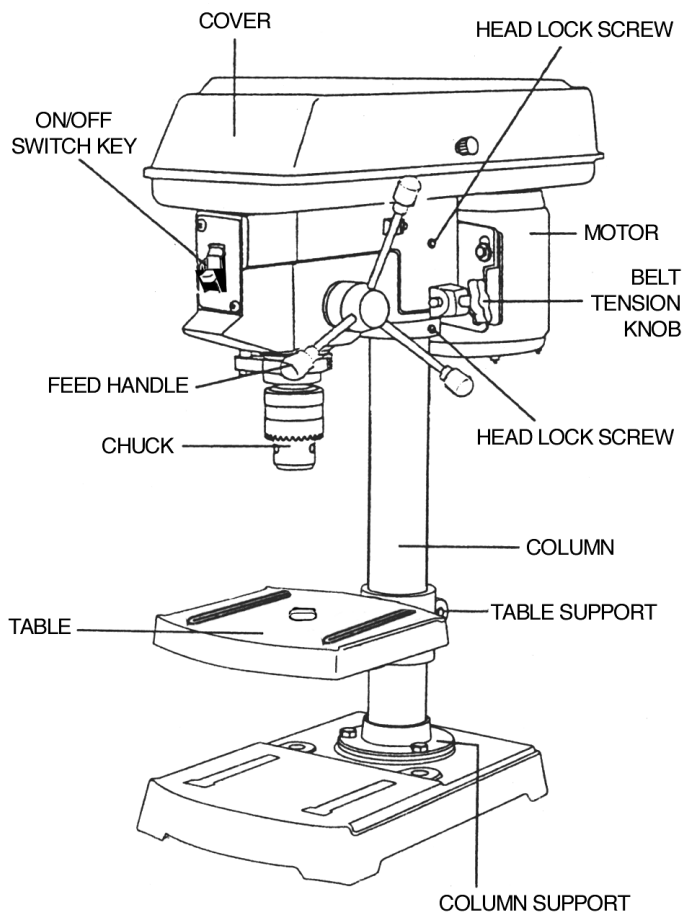
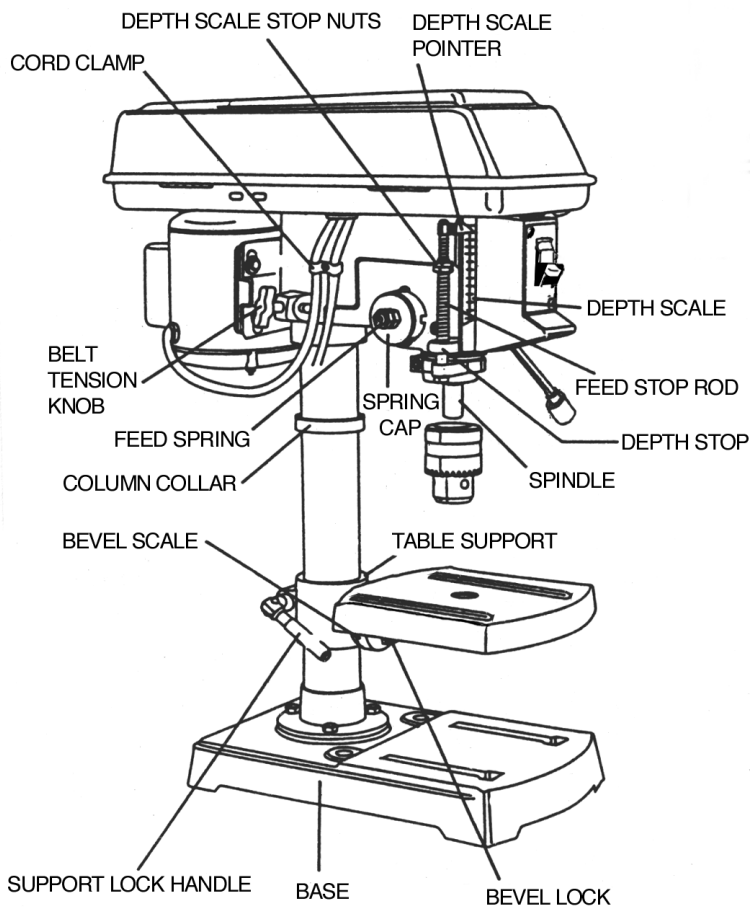

PARTS LIST

PART NO.	DESCRIPTION	Q'TY	PART NO.	DESCRIPTION	Q'TY
1	Base	1	42	Pulley Cover	1
2	Column	1	43	Washer	4
3	Bolt	3	44	Screw	4
3-1	Washer	3	45	V-Belt	1
4	Clamping Sleeve	1	46	Spindle Pulley	1
5	Table	1	47	Headless Set Screw	1
6	Bolt	1	48	Retain Ring	1
7	Clamping Lever	1	49	Internal Spline Sleeve	1
8	Body	1	50	Retaining Ring	1
9	Headless Set Screw	1	51	Ball Bearing	1
10	Nut	1	52	Ball Bearing	1
11	Feed Shaft	1	53	Retaining Ring	1
12	Handle Bar	3	54	Retaining Ring	1
13	Knob	3	55	Ball Bearing	1
14	Headless Set Screw	2	56	Collar	1
15	Shifter Bar	1	57	Spindle Sleeve	1
16	Spring Seat	1	58	Ball Bearing	1
17	Spring Cap	1	59	Spindle	1
18	Nut	1	60	Drill Chuck	1
19	Nut	1	61	Plug	1
20	Switch	1	62	Nut	1
21	Clamping Sheet	1	63	Bolt	1
22	Screw	2	64	Chuck Key	1
23	Bush	2	65	Handle	1
24	Wire	1	66	Washer	1
25	Pointer	1	67	Screw	1
26	Nut	1	68	Screw	1
27	Nut	1	69	Grounding Symbol	1
28	Limit Bolt	1	70	Washer	1
29	Nut	1	71	Washer	1
30	Heel Block	1	72	Manual	1
31	Rubber Washer	1	73	Upper-Inner Carton	1
32	Spring	1	74	Lower-Inner Carton	1
33	Slide Bar	1	75	External Carton	1
34	Rubber Pad	1	76	Hex Key 3mm	1
35	Bolt	3	77	Hex Key 4mm	1
36	Washer	3	78	Switch Box	1
37	Motor Base	1	79	Screw	2
38	Motor	1	80	Screw	2
39	Bolt	2	81	Wire Clamps	2
40	Motor Pulley	1	82	Nut	2
41	Headless Set Screw	1			

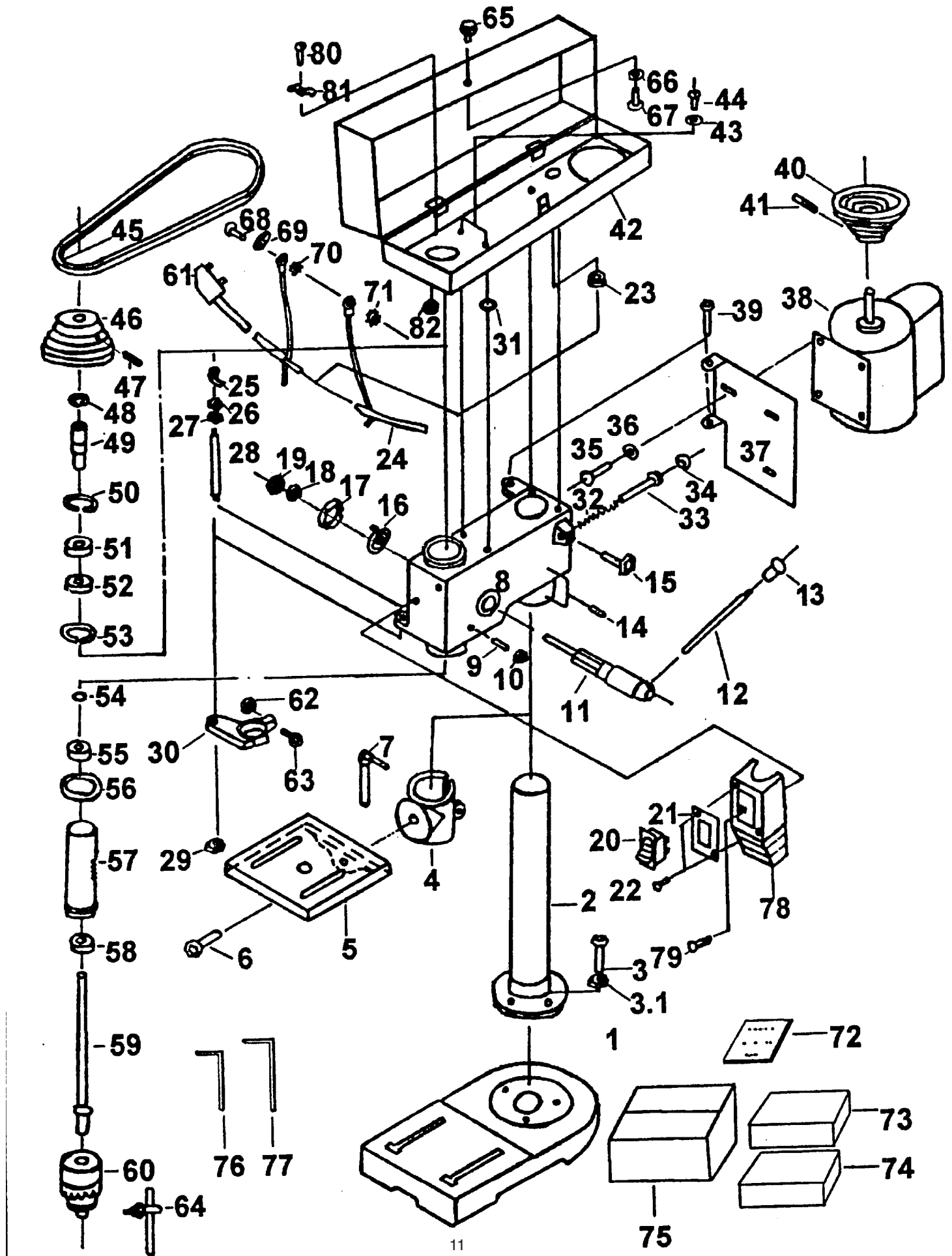

2-1/2" VISE

WARNING: If any parts are missing or damaged at time of purchase DO NOT operate this unit until missing and / or damaged parts have been replaced. Failure to do so could result in possible serious injury. If parts are missing and / or damaged at time of purchase, contact customer service at 800.426.1262.

2-1/2" Vise	1 each
Washers	8 each
1-1/8" Bolt	4 each
Hex Nut	4 each

An adjustable wrench is necessary to install your 2-1/2" Vise.

1. Align the holes on the base of the vise up with the holes on the table of the drill press.
2. Place a washer (2) on a bolt (3) and insert through the vise and the table.
3. On the bottom side of the table place a washer and a hex nut (4) onto the exposed bolt. Tighten finger tight.
4. Repeat steps 1-3 on other remaining 3 bolts.
5. Insure vise is in proper position and tighten bolts with adjustable wrench. Check to make sure that the vise is secure before using.
6. To tighten vise jaws turn support lock handle clockwise, To loosen jaws turn counterclockwise.
7. Keep children and others out of work area.

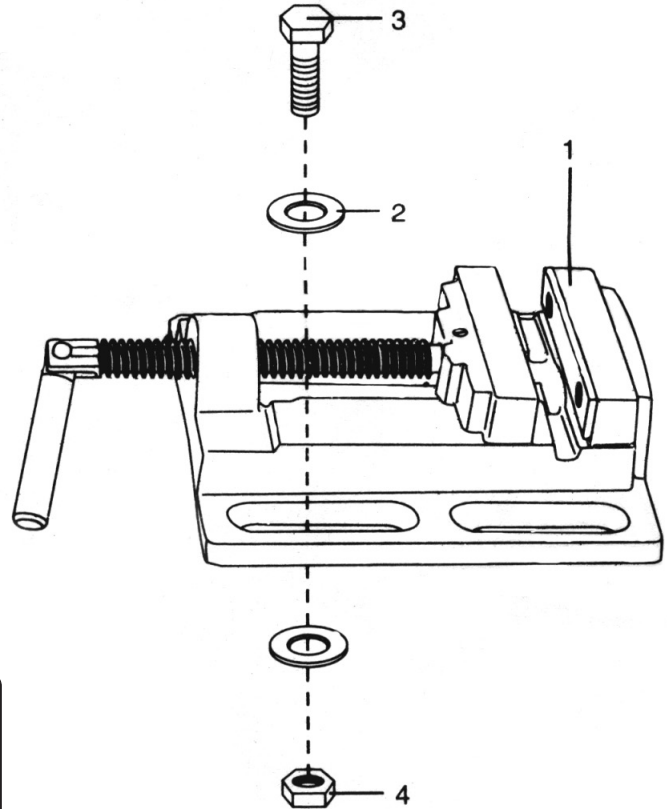

PROTECT YOUR EYES.

The operation of any power tool can result in foreign objects being thrown into the eyes which can result in severe eye damage. Always wear eye protection during power tool operation.

PLEASE WEAR



WARRANTY

LIMITED WARRANTY

PERFORMANCE TOOL extends only the following warranties, and only to original retail purchasers. These warranties give specific legal rights. Except where prohibited by local law, the law of the State of Washington governs all warranties and all exclusions and limitations of warranties and remedies. There may be other rights which vary from state to state.

PERFORMANCE TOOL warrants the product to be free from defects in materials and workmanship under normal use and service. A defective product may be returned for a free replacement within 90 days from the date of purchase, provided that product is returned to place of purchase immediately after discovery of defect. After 90 days and up to 1 year from date of purchase, PERFORMANCE TOOL will replace at no charge any parts which our examination shall disclose to be defective and under warranty. These warranties shall be valid only when a sales receipt showing the date of purchase accompanies the defective product or defective part(s) being returned. For part(s) after 90 days, please remit your request, postage prepaid to: PERFORMANCE TOOL, P.O. Box 24086 Seattle, WA 98124

These warranties exclude blades, bits, punches, dies, bulbs, fuses, and other consumables which must be replaced under normal use and service. These warranties shall not apply to any product or part which is used for a purpose for which it is not designed, or which has been repaired or altered in any way so as to affect adversely its performance or reliability, nor shall these warranties apply to any product or part which has been subject to misuse, neglect, accident or wear and tear incident to normal use and service.

PERFORMANCE TOOL does not authorize any other person to make any warranty or to assume any liability in connection with its products.

Except for warranties of title and the limited express warranties set forth above, PERFORMANCE TOOL makes no express or implied warranties of any kind with respect to its products. In particular, PERFORMANCE TOOL makes no implied warranty of merchantability and no implied warranty of fitness for any particular purpose, except that for goods purchased primarily for personal, family or household use and not for commercial or business use, PERFORMANCE TOOL makes an implied warranty of merchantability (and, if otherwise applicable, an implied warranty of fitness for a particular purpose), but only for the particular qualities or characteristics, and for the duration, expressly warranted above. The laws on limitation of implied warranties may differ from state to state, so the above limitations may not apply in all cases.

PERFORMANCE TOOL shall not be liable for consequential, incidental or special damages resulting from or in any manner related to any product, or to the design, use, or any inability to use the product. The sole and exclusive remedy for a defective product or part shall be the repair, or replacement thereof as provided above. The laws on limitation of remedies or on consequential, incidental or special damages may vary from state to state, so the above limitations may not apply in all cases.

Copyright © 2015 PERFORMANCE TOOL P.O. Box 88259 Tukwila, WA 98138 – All rights reserved