



Project Name: \_\_\_\_\_

Location: \_\_\_\_\_

Item #: \_\_\_\_\_ Qty: \_\_\_\_\_

Model: \_\_\_\_\_

# 15 INCH COUNTERTOP OR BUILT-IN ICE MAKER

MODEL:  MIMC15C



MIMC15C

The Maxx Ice MIMC15C produces up to 15 pounds of crescent ice cubes per day, up to 4 times as much as your standard household freezer ice maker. Its compact front-breathing design make it suitable for built-in applications while the fact that it does not need a drain line gives you even more flexibility to install in a wide variety of locations with ease. The stylish stainless steel reversible door and finished black exterior will look great anywhere.

## FEATURES AND CONSTRUCTION

- Produces up to 15 lbs of ice per day, up to 4x as much as a standard household freezer ice maker
- Ice storage bin holds up to 12 lbs and is removable for easy access to the ice
- The interior is a freezer so the ice stays frozen – no drain required
- Compact design with a height of 24.8” allows installation under a counter and is also ADA Compliant
- Stainless steel door is stylish and field-reversible for left or right handed operation
- Door-close assist feature forms a strong seal when door is closed and also prevents accidental opening
- Simple and worry-free On/Off switch with automatic shutoff when the ice bin is full
- Adjustable feet for leveling the unit and installing at the perfect height
- The unit must be periodically manually defrosted
- Includes ice scoop and water inlet hose

## ELECTRIC

115V / 60Hz / 1Ph  
International voltage available  
6' (1.9m) NEMA 5-15P cord set included

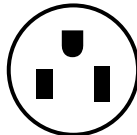

NEMA 5-15P

## DAILY ICE PRODUCTION

Air Temp 50°F (10°C) / Water Temp 50°F (10°C)  
MIMC15C ..... 15 lbs (6.8 kg)

## ICE BIN STORAGE CAPACITY

MIMC15C ..... 12 lbs (5.4 kg)

## 3RD PARTY APPROVALS



## MAXX ICE WARRANTY (USA / CANADA)

Contact Maxx Ice for warranty statement at  
TechnicalServices@TheLegacyCompanies.com or 877.368.2797

## OPERATING REQUIREMENTS

Ambient Air Temperature Range..... 50° to 100°F (10° to 38°C)  
Water Temperature Range ..... 40° to 90°F (4° to 32°C)  
Water Usage per 100 lbs of ice..... 12.6 Gallons (47.7L)  
Water Supply Line Connection ..... 1/4” O.D. Compression  
Water Pressure Range:

Min PSI..... 20                      Max PSI .....80\*  
Min Bar ..... 1.0                      Max Bar.....5.5

\*Above 75 PSI requires a regulator



# MAXX ICE

## 15 INCH COUNTERTOP OR BUILT-IN ICE MAKER

### SIDE VIEW

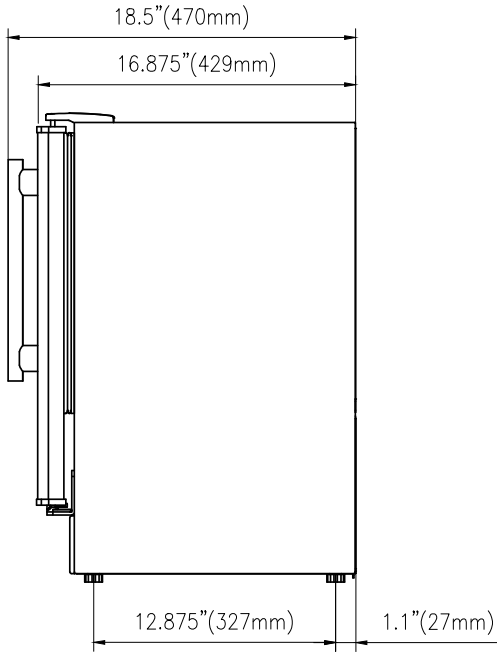

### FRONT VIEW

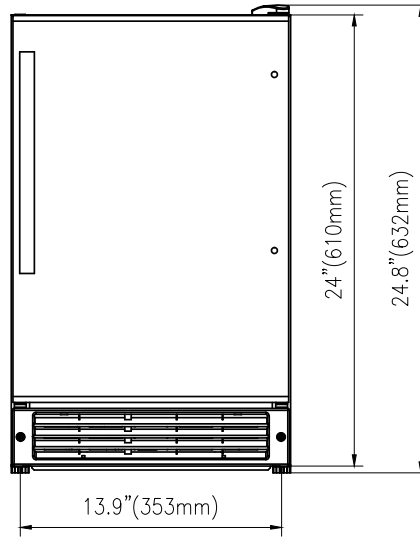

### TOP VIEW

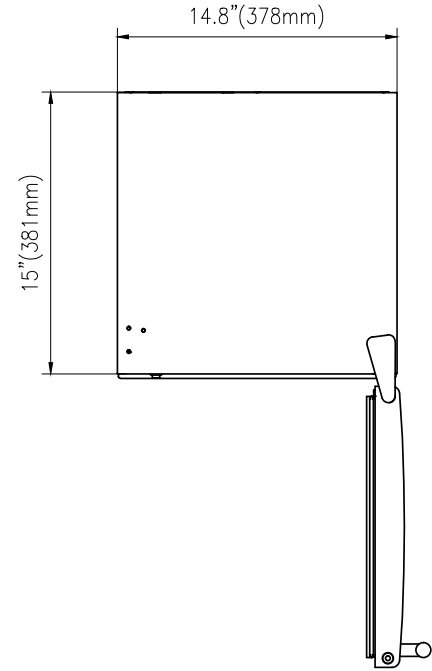

### CRESCENT CUBE (ACTUAL SIZE)

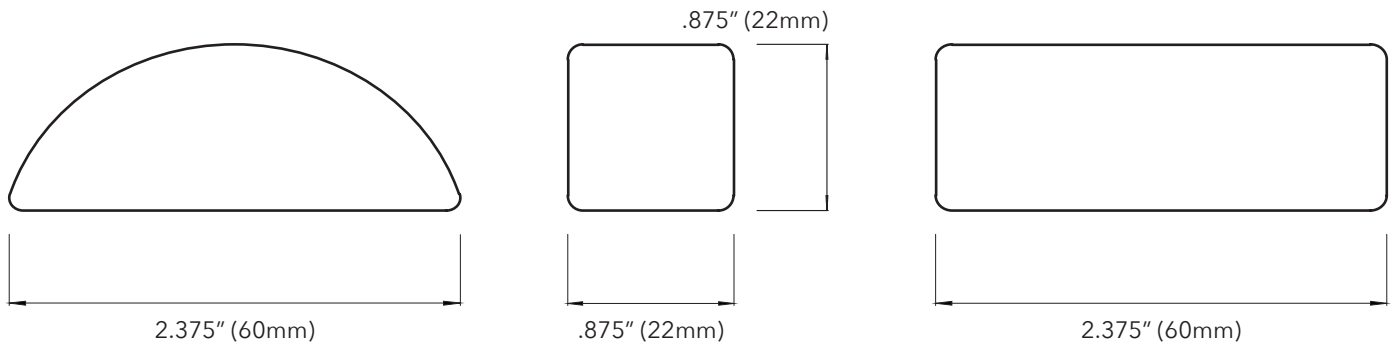

| MODEL   | EXTERNAL DIMENSIONS                           | DAILY ICE PRODUCTION (70°F Air / 50°F Water) | ICE BIN STORAGE CAPACITY | NET WEIGHT / SHIPPING WEIGHT     | AMP DRAW (MAKING / HARVESTING) | REFRIGERANT AND CHARGE SIZE | ELECTRICAL        |
|---------|---|--|--------------------------|----------------------------------|--------------------------------|-----------------------------|-------------------|
| MIMC15C | 14.8" x 18.5" x 24.8"<br>(378 x 470 x 632 mm) | 15 lbs (6.8 kg)                              | 12 lbs (5.4 kg)          | 50 lbs (23 kg)<br>60 lbs (27 kg) | 1.2A / 2.7A                    | R-600a<br>1.69oz (48g)      | 115V / 60Hz / 1Ph |

### INSTALLATION

- All ventilation from front, limited vent in the back of unit - no additional clearance required around sides of unit
- Requires incoming water line - no drain required