

# K36/40 Fitting

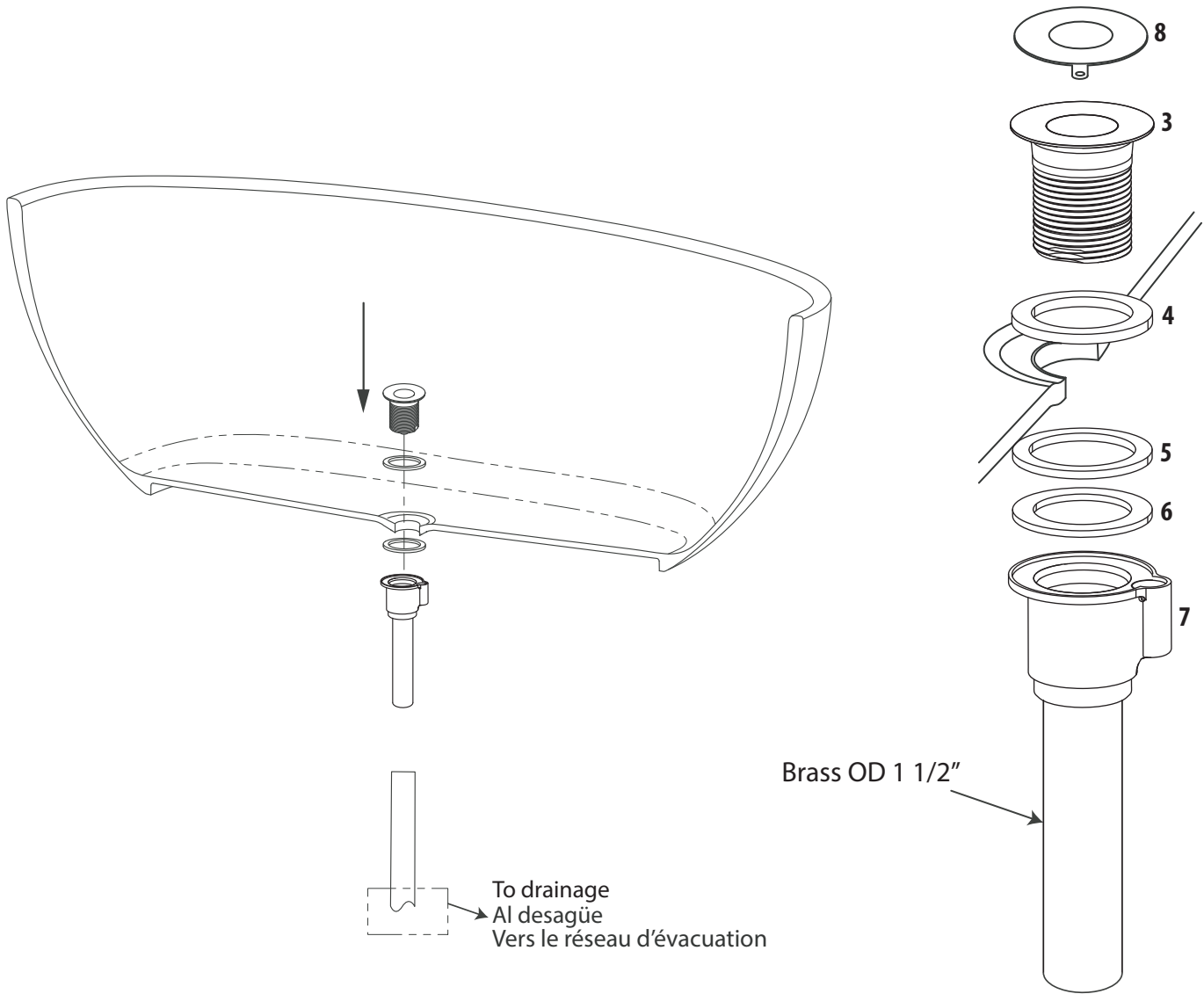

Connection, V+A recommend "Profex" or "No-Hub" couplings, other choices are available. Always check local plumbing code.

Conexión, V+A recomienda acoples "Profex" o "No-Hub", hay disponibles otras opciones. Consulte siempre los códigos de plomería locales.

Raccordement, V+A recommande des raccords « Profex » ou « sans moyeu »; autres choix offerts. Toujours consulter le code de plomberie local.

## K36E/K40E



Maximum horizontal run to trap = 300mm/12"

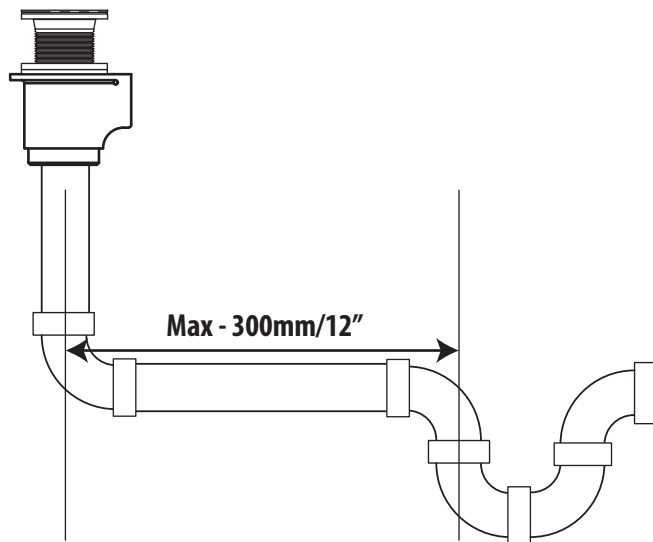

# K36/40 Fitting

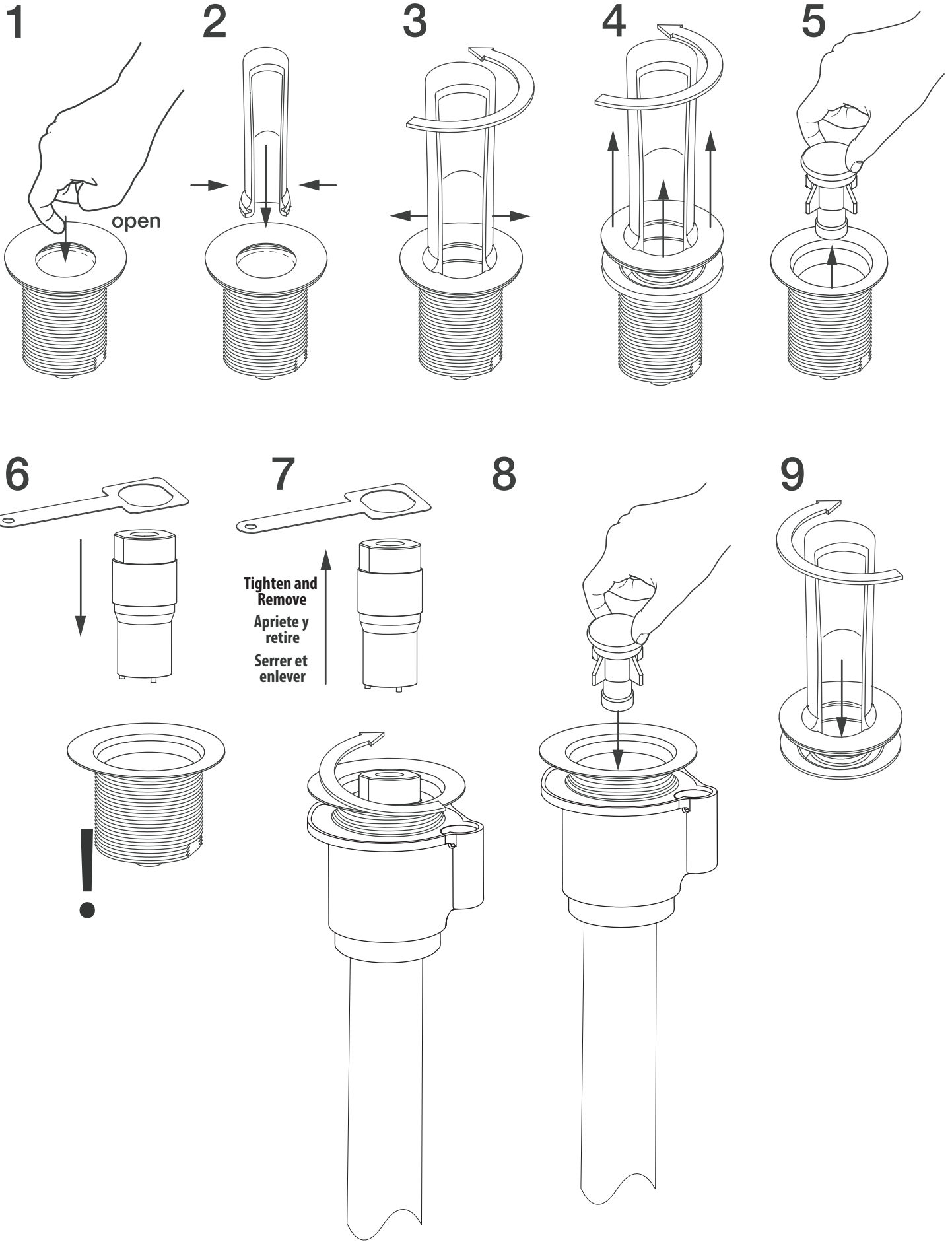

# K36/40 Testing



CHECK  
COMPROBAR  
VÉRIFIER  
ÜBERPRÜFEN

1

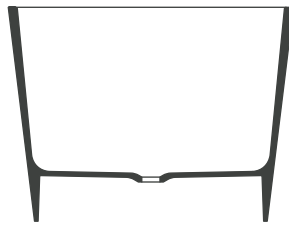

2

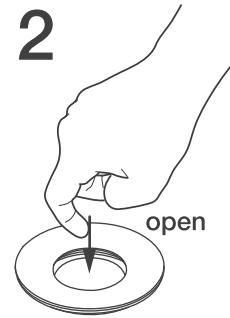

3

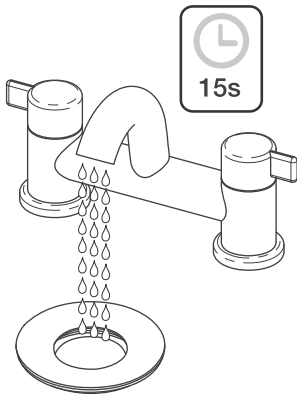

4

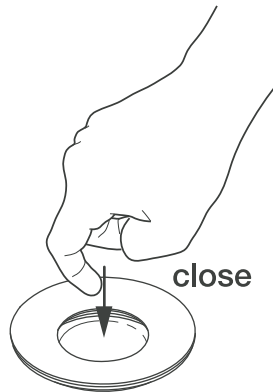

5

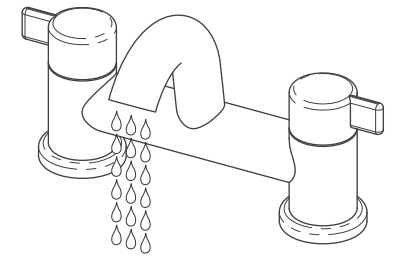

6

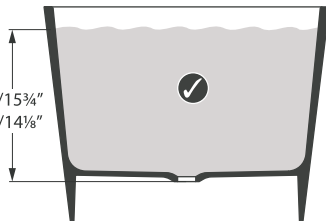

K40 = 400mm/15¾"  
K36 = 360mm/14⅝"

7

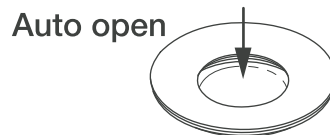

8

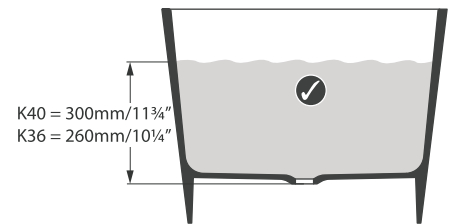

K40 = 300mm/11¾"  
K36 = 260mm/10¼"

9



10

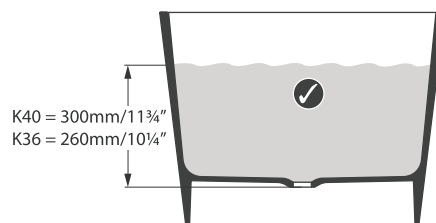

K40 = 300mm/11¾"  
K36 = 260mm/10¼"

11



# K36/40 Cleaning

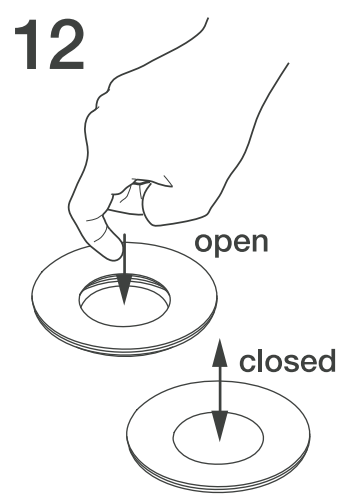
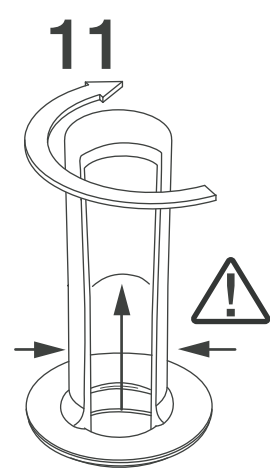
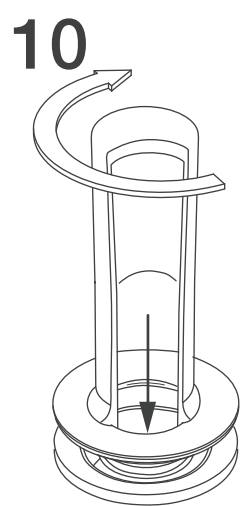
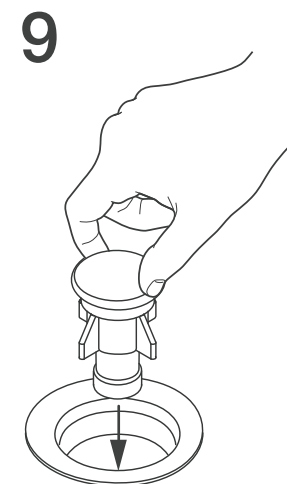
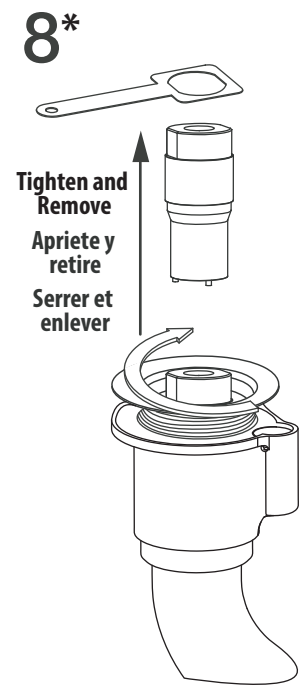
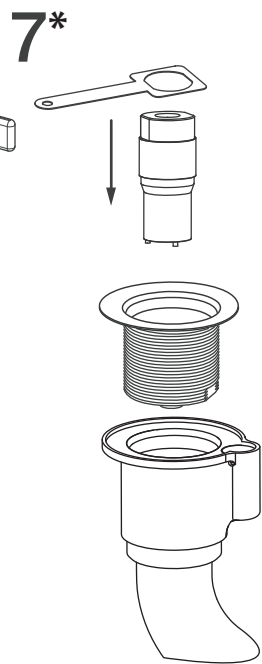
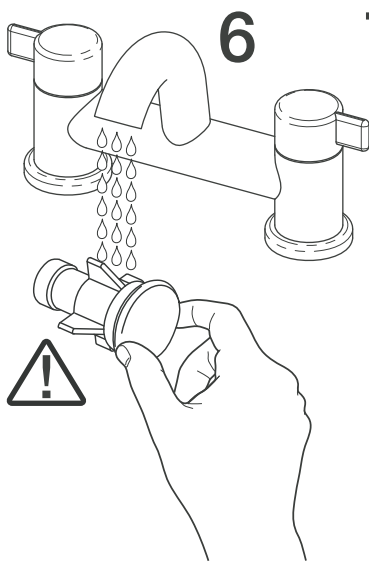
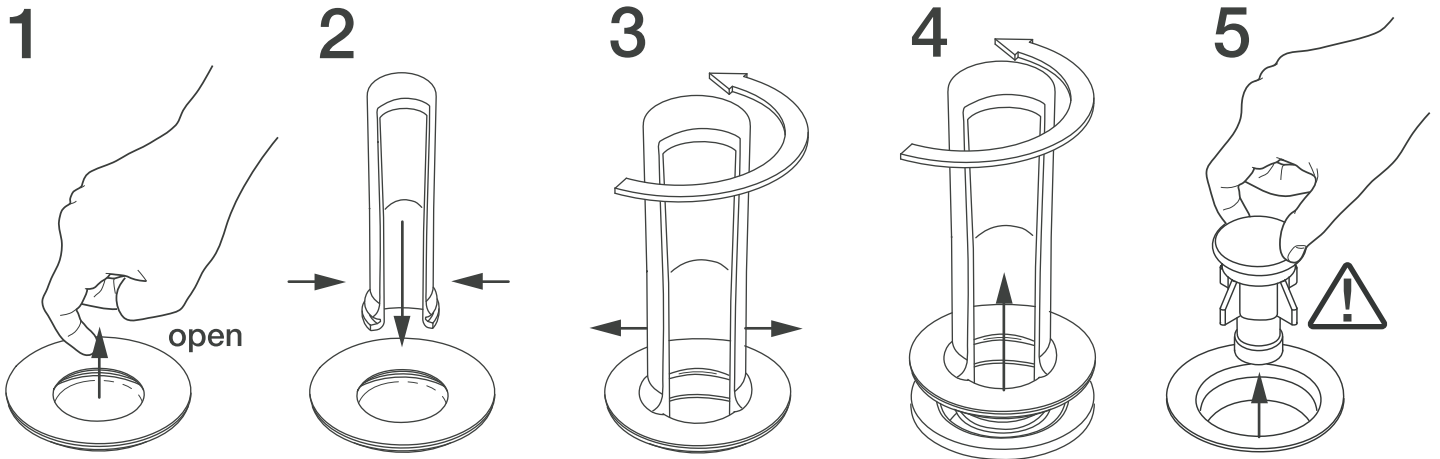

**\* Only to ensure the waste did not come loose.**

**\*Sólo para asegurarse de que el desagüe no quedó suelto.**

**\*Seulement pour s'assurer que la bonde ne se desserre pas.**

# K36/40 Cleaning



EN: Leave water flushing for 15 seconds before closing the valve and filling the bath

ES: Deje correr el agua durante 15 segundos antes de cerrar la válvula y llenar la tina.

DE: Lassen Sie Wasser für 15 Sekunden spülen bevor dem Schließen des Ventils und Befüllen der Badewanna

IT: Lasciare correre l'acqua per 15 secondi prima di chiudere il tappo e riempire la vasca

FR: Laisser l'eau couler pendant 15 secondes avant de refermer la bonde et de remplir la baignoire

