



Project Name: \_\_\_\_\_

Location: \_\_\_\_\_

Item #: \_\_\_\_\_ Qty: \_\_\_\_\_

Model: \_\_\_\_\_

# WATER BATH STEAM TABLE - ELECTRIC / OPEN BASE

MODEL:  EST-240 - 4 BAY



EST-240 - 4 BAY  
Shown with optional cutting board and tray holder

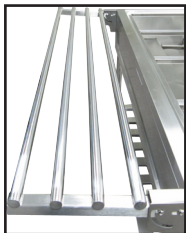

EST-240/TH  
Tray Holder



304 Stainless Steel  
Water Pan Well



EST-240/PCB  
9" Cutting Board

## ELECTRIC

208V/240V  
5' NEMA 6-20P cord set included



NEMA 6-20P

## ADCRAFT WARRANTY (USA / CANADA)

These units are backed by a 1 year limited replace or repair warranty (parts only for Canada). For warranty, non-warranty related issues, and technical support, call NSA at 877.672.7740 or contact support@admiralcraft.com.

Admiral Craft Equipment Corp. • 3355 Enterprise Avenue, Suite 160 • Fort Lauderdale, FL 33331  
Sales: 516-433-3535 • orders@admiralcraft.com • www.admiralcraft.com

Adcraft's electric water bath steam table is constructed of all stainless steel. All four top openings fit a 12" x 20" full size food pan with no additional water pans needed. The stainless steel water pan is fully welded and has a recessed well that houses the immersed heating element. Thermostatic temperature dial allows for accurate food holding temperature. Comes standard with adjustable stainless steel legs, undershelf and a 3/4" drainage pipe for easy removal of water. The steam table is customized with the optional stainless steel tray rack and optional 9" wide polycarbonate cutting board shelf. This unit ships knocked down and assembly is required. This unit is backed by Adcraft's 1 year limited warranty.

## CONSTRUCTION

- Heavy duty stainless steel body and well
- 4 top openings that fit 12" x 20" full size food pans
- Stainless steel legs with adjustable bullet ends
- Undershelf for storage

## WATER PAN

- Fully welded 304 stainless steel construction
- Recessed well with 3000W immersed heating element
- 3/4" drain for quick and easy draining

## ELECTRICAL

- Single 3000W heating element that runs throughout the bottom of the water well
- Thermostatic control dial
- 5' power cord with NEMA 6-20 plug extends out from underneath the unit
- Low water cutoff sensor with reset button
- 208V/240V, 3000W, 12.5 Amps

## AVAILABLE OPTIONS & ACCESSORIES

- EST-240/TH - Stainless steel tray holder (hardware sold separately)
- EST-24 - Hardware with bracket for tray slide
- EST-240/PCB - 9" wide cutting board and s/s shelf (hardware sold separately)
- EST-23 - Hardware with support for cutting board

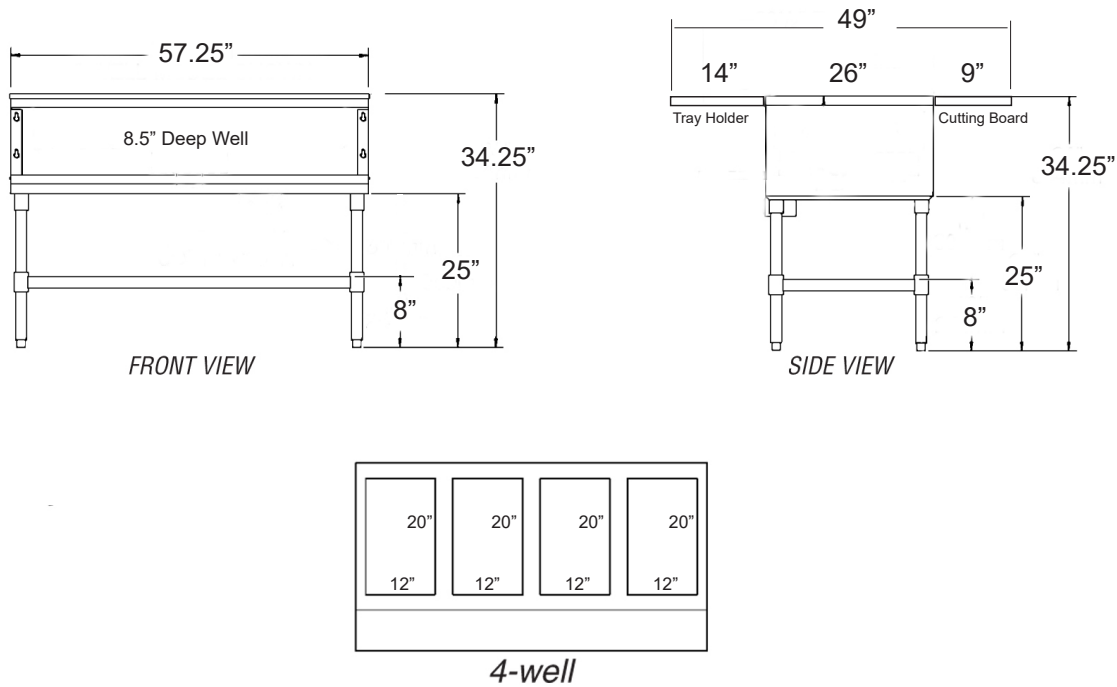

### SPECIFICATIONS

ITEM NUMBER	WELL OPENINGS	VOLTS	WATTAGE	AMPS	NEMA PLUG
EST-240	4	208V/240V	3000W	12.5	6-20P

### SHIPPING INFO

ITEM NUMBER	DESCRIPTION	DIMENSIONS (W x D x H)	GROSS WEIGHT	NET WEIGHT
EST-240	Water Bath Steam Table - 4 Bay	57.25" x 26" x 34.25"	79 lbs	68 lbs
EST-240/TH	Stainless Steel Tray Holder	57.25" x 14" x 2"	10 lbs	10 lbs
EST-240/PCB	Polycarbonate Cutting Board w/shelf	57.25" x 9" x 1"	20 lbs	18.75 lbs