

PRODUCT SPECIFICATIONS

Elkay Quartz 8 ounce Rejuvenator. Overall dimensions are 2-1/2" x 2-1/2" x 7-1/4".

Dimensions:	2-1/2" x 2-1/2" x 7-1/4"
Shipping Weight:	.5 lbs.

- Keep the rich hues of Elkay quartz sinks vibrant by using our rejuvenator as a polish from time to time.



A Century of Tradition and Quality.

For more than 100 years, Elkay has been making innovative products and providing exceptional customer care. We take pride in offering plumbing products that make life easier, inspire change and leave the world a better place.

[Warranty \(PDF\)](#)

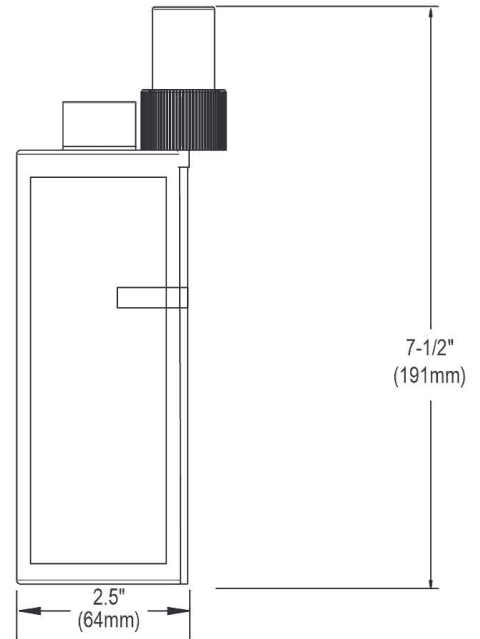

PART: _____ QTY: _____

PROJECT: _____

CONTACT: _____

DATE: _____

NOTES: _____

APPROVAL: _____

In keeping with our policy of continuing product improvement, Elkay reserves the right to change product specifications without notice. Please visit elkay.com for the most current version of Elkay product specification sheets. This specification describes an Elkay product with design, quality, and functional benefits to the user. When making a comparison of other producers' offerings, be certain these features are not overlooked.