

SIDES	BOTTOM
6 1/2" KNOCKOUTS	3 1/2" KNOCKOUTS
3 1/2"-3/4" MOON KNOCKOUTS	2 1/2"-3/4" MOON KNOCKOUTS
2 PCS 8-32x1/2 Screws Installed	
Material:Steel-0.0625"-G60 Galvanized	

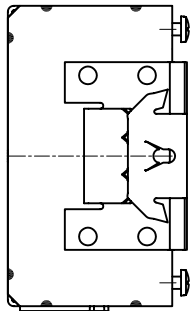
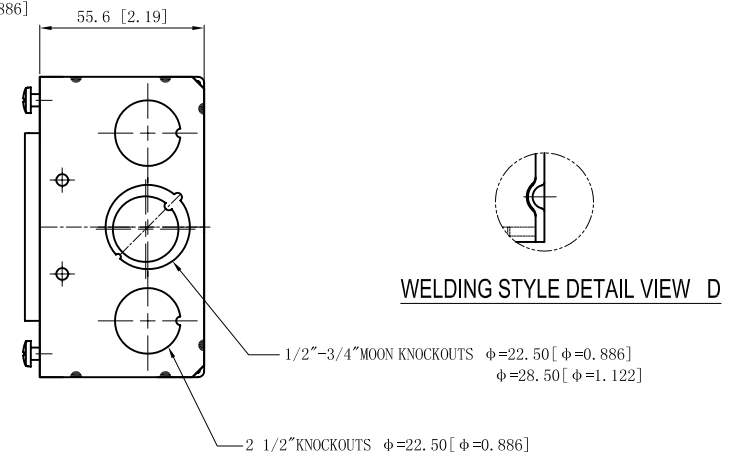
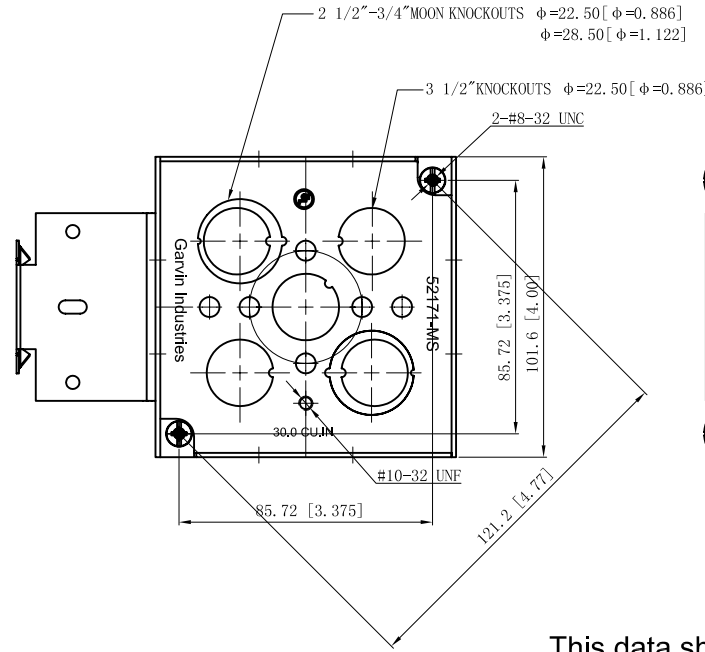
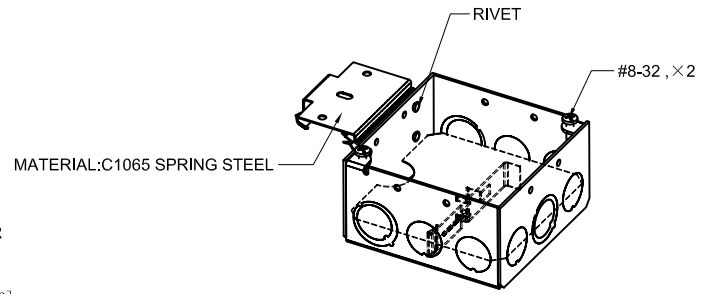
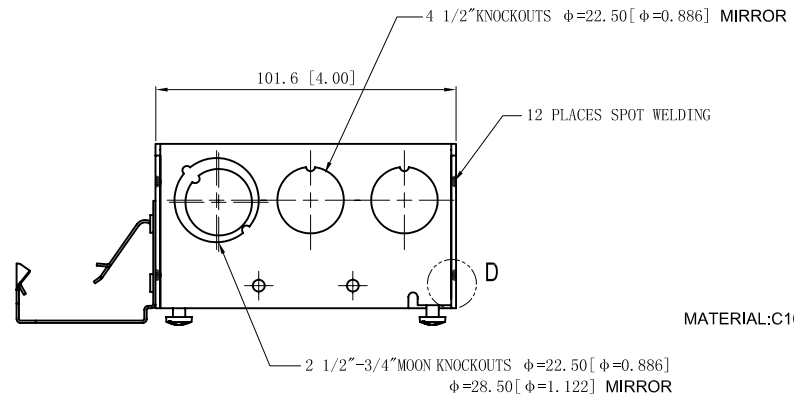

DESCRIPTION
TRADE REFERENCE TERMS

This data sheet is for reference only .GARVIN INDUSTRIES reserves the right to make changes to the design without prior notice.

STANDARD PACKING	GARVIN INDUSTRIES		
	4" SQUARE BRACKET BOXES (2-1/8" DEEP)		
25 PCS	TITLE	52171-MS	
	SIZE	DWG NO.	REV
	A4		D
		DATA SHEET	