



Project _____
 Item # _____
 Quantity _____

Commercial Water Boilers

Models: EWB-50A | EWB-100A | EWB-100A-I

Always have hot water handy with the Winco water boiler. This water boiler is sure to be a great additional to any hot beverage service.

Standard Features

- ◆ Large 2.1 gallon (8L) or 4.2 gallon (16L) capacities
- ◆ Polished #304 stainless steel construction
- ◆ Twist-locking lid design
- ◆ Cool touch handles
- ◆ Dripless faucet with protected level indicator
- ◆ Waterproof ON/OFF switch with protective cover
- ◆ Heating and holding indicator lights
- ◆ Automatic shut-off safety feature
- ◆ One year parts and labor warranty



EWB-50A
 EWB-100A
 Intertek
 CE
 EWB-100A-I

Parts

EWCU-P3	Faucet Assembly
EWCU-P4	Water Gauge Assembly for EWB-50A
EWCU-P5	Water Gauge Assembly for EWB-100A
EWCU-P19	Locking Lid Assembly for EWB-50A
EWCU-P20	Locking Lid Assembly for EWB-100A

Options & Accessories

SGN-series	Stainless Steel Beverage Signs
DT-series	Drip Trays
VSW-series	Push Button Beverage Servers
CF-series	Beverage Carafes
VSS-series	Coffee/Cream Servers
CLO-series	Cup & Lid Organizers
CLSO-series	Cup & Lid Organizers

For California Customers
WARNING: Cancer and Reproductive Harm - www.P65Warnings.ca.gov

Winco®, DWL International Trading, LLC

www.wincous.com | equipsales@wincous.com

New Jersey Headquarters:
 65 Industrial Road, Lodi, NJ 07644
 Tel. 1.888.946.2682 | Fax: 1.888.946.2632

California Distribution Center
 14950-14952 Valley View Avenue, La Mirada, CA 90638
 Tel. 1.888.946.2652 | Fax: 1.562.926.5678

Florida Distribution Center
 10800 NW 103rd St. Bldg 22, Ste 11, Miami, FL 33178
 Tel. 1.786.536.4656

Winco® Commercial Water Boilers

Models: EWB-50A | EWB-100A | EWB-100A-I

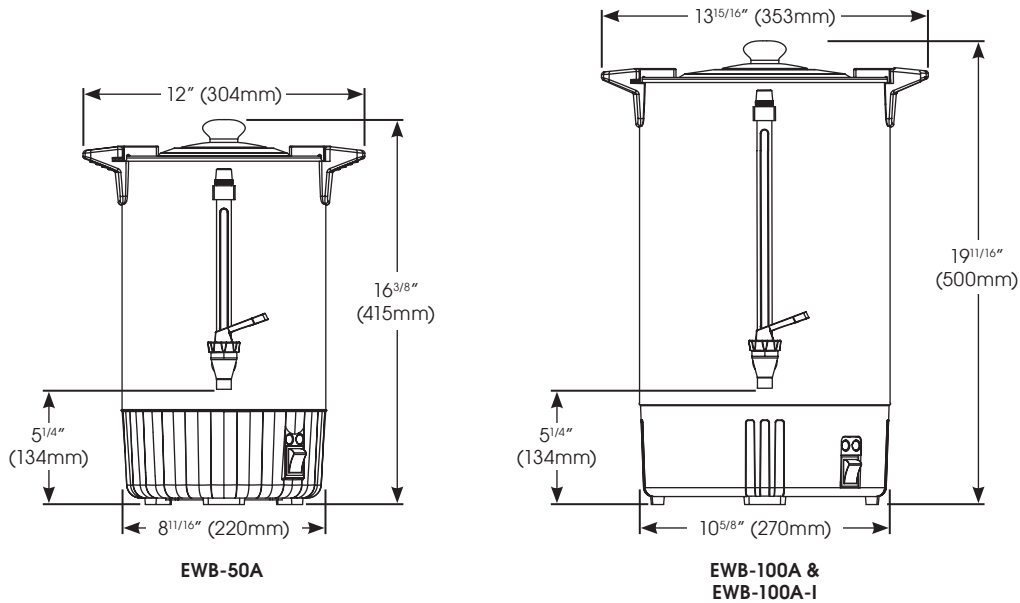

Specifications

MODEL	DESCRIPTION	OVERALL DIMENSIONS			VOLTS	HZ	WATTS	AMPS	PLUG	SHIP WEIGHT
		LENGTH	DEPTH	HEIGHT						
EWB-50A	2.1 Gallon (8 L)	12\"/>								

Cord Location

On back right side

Plug Configuration

NEMA 5-15P

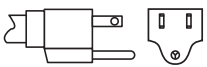

EWB-50A
EWB-100A

VDE

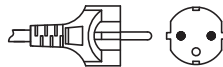

EWB-100A-I

Product Specs

Commercial Water Boiler

The Commercial Water Boilers models EWB-50A, EWB-100A, and EWB-100A-I as manufactured by Winco®, Lodi, NJ 07644.

The Commercial Water Boiler model EWB-50A with a 2.1 gallon (8L) capacity shall be rated at 1300 Watts and model EWB-100A with a 4.2 gallon (16L) capacity shall be rated at 1500 Watts. Both units are rated for 110-120V-60Hz and supplied with a NEMA 5-15P plug. Model EWB-100A-I with a 4.2 gallon (16L) capacity shall be rated at 2250 Watts for 220-240V-50-60Hz and supplied with a VDE plug. All units shall be constructed of polished #304 stainless steel with cool-touch handles. Units shall be equipped with a twist-locking lid, dripless faucet with protected level indicator, and waterproof ON/OFF switch with protective cover, heating and holding indicator lights, and automatic shut-off safety feature.

CE and ETL listed for safety (Canada & US).

Warranty consists of one year parts and labor.

Winco®, DWL International Trading, LLC

New Jersey Headquarters:
65 Industrial Road, Lodi, NJ 07644
Tel. 1.888.946.2682 | Fax: 1.888.946.2632

California Distribution Center
14950-14952 Valley View Avenue, La Mirada, CA 90638
Tel. 1.888.946.2652 | Fax: 1.562.926.5678

Florida Distribution Center
10800 NW 103rd St. Bldg 22, Ste 11, Miami, FL 33178
Tel. 1.786.536.4656

www.wincous.com | equipmentsales@wincous.com