

# FLEXSTEEL®

## W1077-834

### Round Dining Table

#### IMPORTANT NOTE

Carefully remove all the parts from the carton and put them individually on a soft cloth to prevent damage to the parts.

We have taken great care in the design of this product and request that you carefully and strictly follow our assembly instructions to ensure a completed product as it was designed.

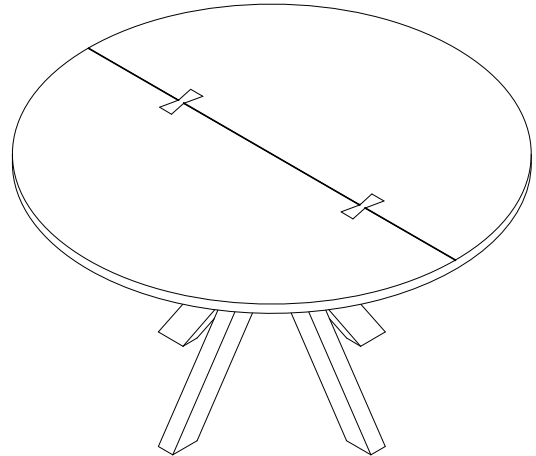

#### Part List

#### Assembly Instructions 1/3

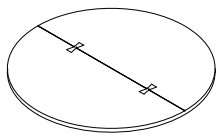

A. Table Top  
1 piece



B. Table Leg  
4 pieces

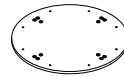

C. Connecting Panel  
1 piece



D. Metal Bar  
1 piece

#### Hardware List



1. Flat Washer  
 $\Phi 5/16 \times 19 \times 1.5\text{mm}$   
36 pieces



2. Spring Washer  
 $\Phi 5/16"$   
36 pieces



3. Long Bolt  
 $\Phi 5/16" - 18 \text{ UNC} \times 32\text{mm}$   
20 pieces



4. Short Bolt  
 $\Phi 5/16" - 18 \text{ UNC} \times 20\text{mm}$   
16 pieces

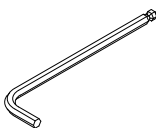

5. Hex Key  
 $110 \times 25 \times 4\text{mm}$   
1 piece

Tool(s) recommended for assembly: Level

### IMPORTANT NOTES

- Do not tighten up all the bolts until each part is properly assembled.
- Keep the Hex Key in a safe place as you may need to tighten up the bolts in the future.
- Use a soft cloth between these parts and the floor.
- We recommend this product be assembled by at least two adults.

### STEP 1

Attach Table Leg (B) to Metal Bar (D) by 4 Short Bolt (4), 4 Spring Washer (2) and 4 Flat Washer (1) loosely, repeat this step on each leg, level all legs then fully tighten with Hex Key (5). (See Figure 1.)

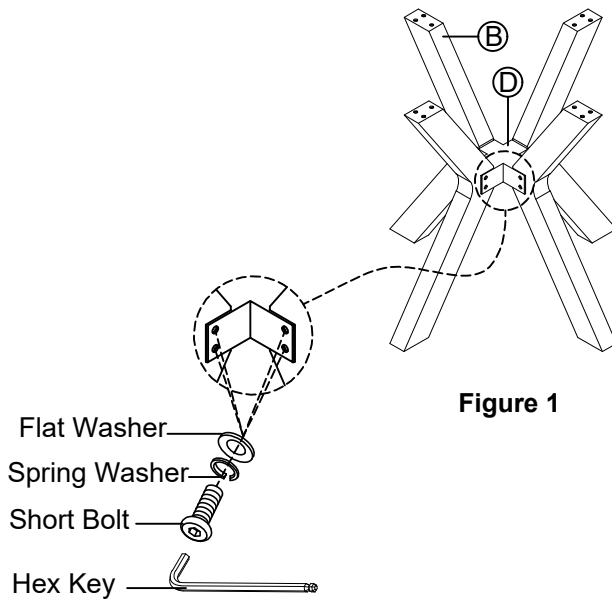

### STEP 2

Assemble Connecting Panel (C) to Table Leg (B) with 12 Long Bolts (3), 12 Spring Washer (2) and 12 Flat Washer (1), fully tighten with Hex Key (5). (See Figure 2.)

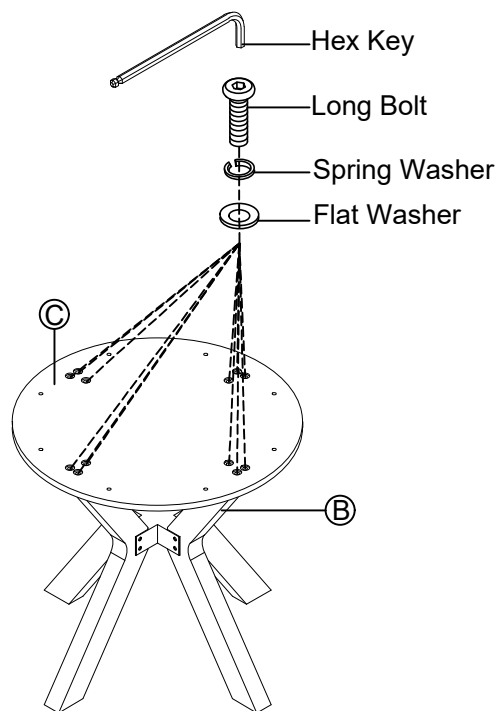

Figure 2

### STEP 3

Attach Connecting Panel (C) to Table Top (A) by 8 Long Bolt (3), 8 Spring Washer (2) and 8 Flat Washer (1), fully tighten with Hex Key (5). (See Figure 3.)

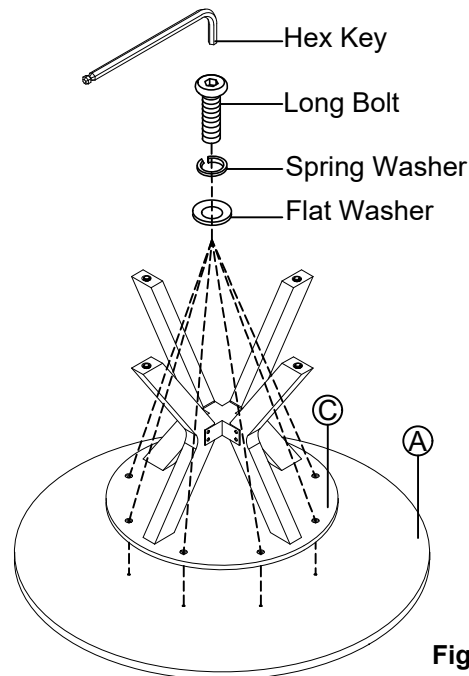

Figure 3

### STEP 4

Flip Table over and adjust the levelers on the legs until the furniture is leveled. (See Figure 4.)

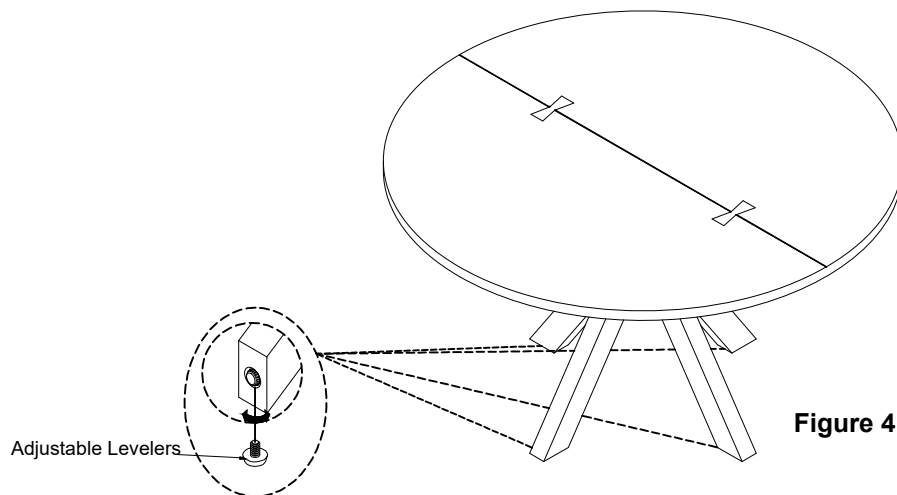

Figure 4

### CARE INSTRUCTIONS

- To avoid scratches, do not place sharp or jagged objects directly on the table top.
- Do not place hot items directly on the tabletop.
- Use placemats or trivets under hot items and coasters under beverages to prevent marks and stains.
- Avoid the use of harsh chemicals or abrasive cleaning materials.
- Wipe the table clean with a soft, dry cloth after each use.
- Wipe up spills quickly with a soft, dry cloth.

**Flexsteel Industries, Inc.**

For Parts or Customer Service call toll-free: 1-888-415-3979

Monday-Friday, 8:00-5:00pm Central Time

Email: [customersolutions@flexsteel.com](mailto:customersolutions@flexsteel.com)

[www.flexsteel.com](http://www.flexsteel.com)