

# CAMDEN PANEL FULL BED

## ASSEMBLY INSTRUCTIONS



### PARTS PACKING CONFIGURATIONS

**BOX #1:**  
A. HEADBOARD 1 PC

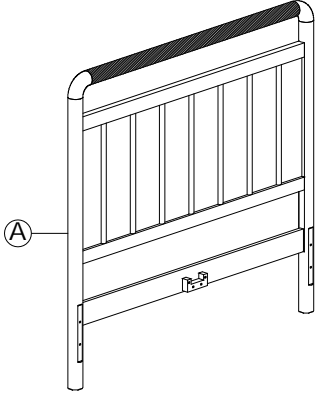

**BOX #2:**  
B. FOOTBOARD 1 PC  
C. SLAT ROLL 1 SET

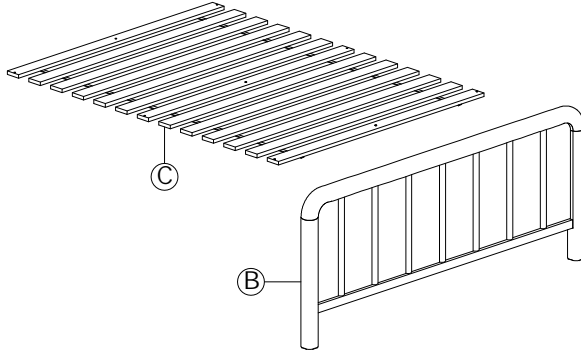

**BOX #3:**  
D. SIDE RAILS 2 PCS  
E. SLAT SUPPORT LEG 3 PCS  
F. CENTER SLAT SUPPORT 1 PC

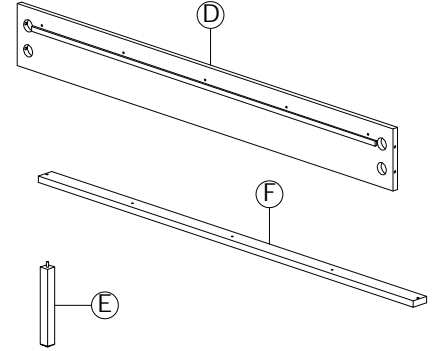

### FULLY ASSEMBLED

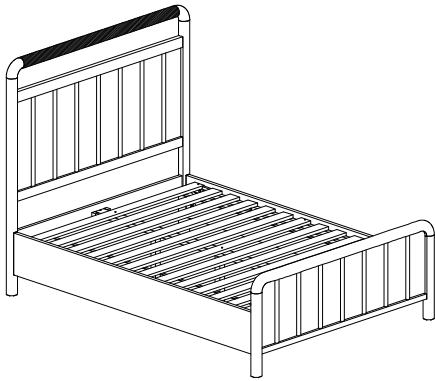

### HARDWARE KIT PACKED IN BOX #2

No.	Description	Image	Quantity
1	THREADED BOLT (8x90mm)		8 PCS
2	HALF MOON WASHER (7x14x27mm)		8 PCS
3	HEX NUT (M8)		8 PCS
4	ALLEN KEY (4mm)		1 PC
5	WOOD SCREW (4x30mm)		11 PCS
6	WRENCH (13mm)		1 PC



### STEP 1:

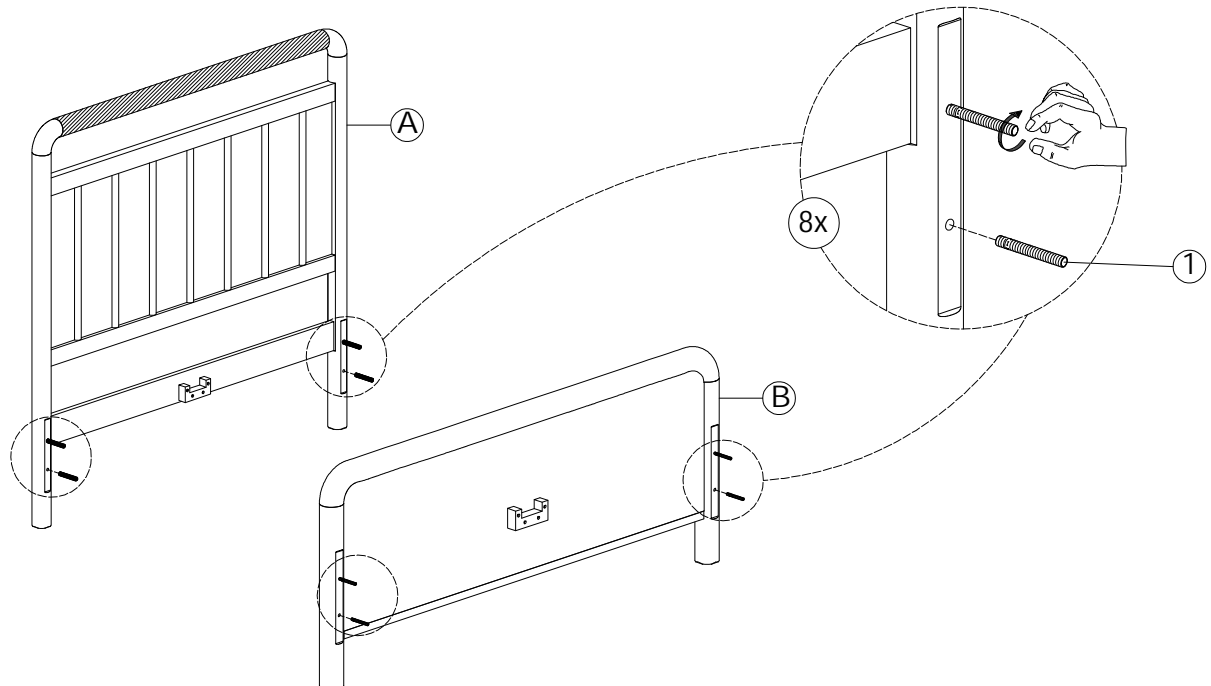

# CAMDEN PANEL FULL BED

## ASSEMBLY INSTRUCTIONS



### STEP 2:

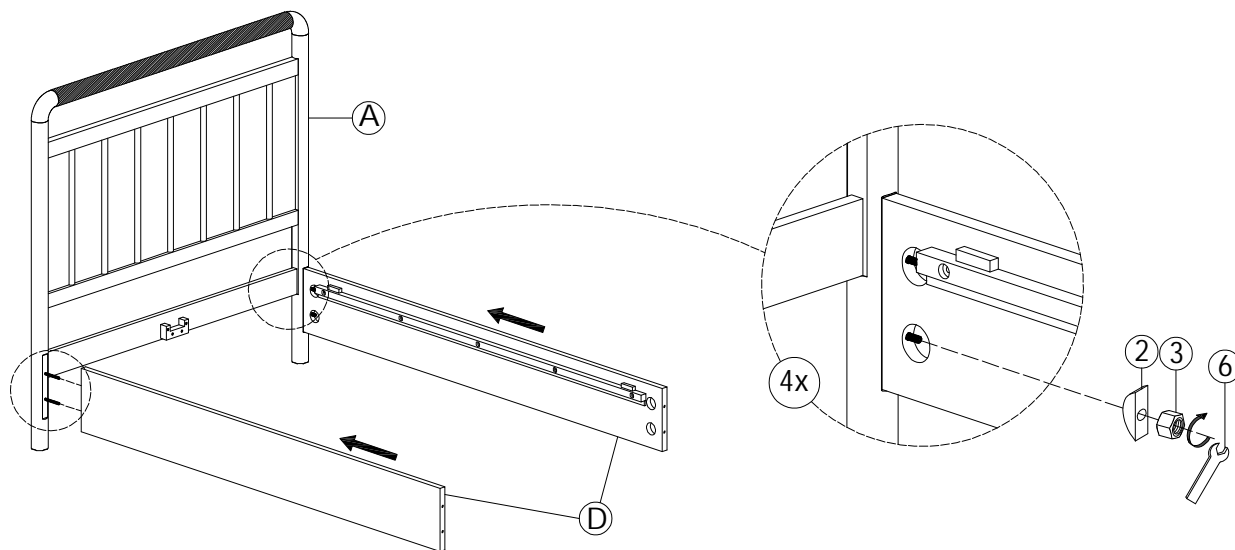

### STEP 3:

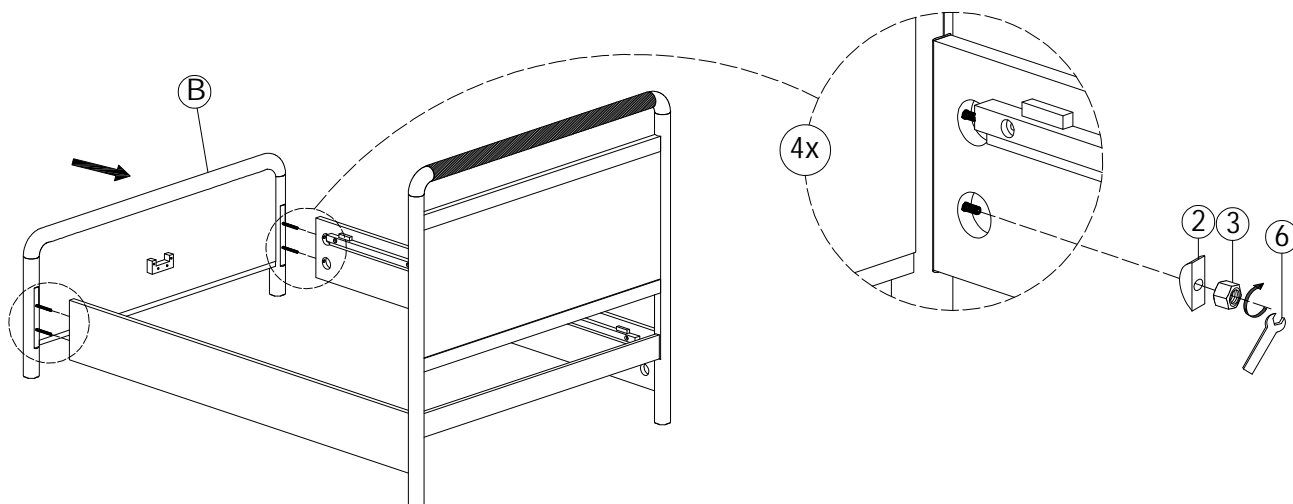

### STOP

- IF USING BED WITH AN ADJUSTABLE MATTRESS BASE, SKIP STEPS 4, 5, 6 & 7 AND REFERENCE APPENDIX A: ADJUSTABLE MATTRESS BASE ASSEMBLY SUPPLEMENT.
- IF USING BED FRAME WITH STANDARD BOX SPRING OR FOUNDATION, CONTINUE TO STEP 4

### STEP 4:

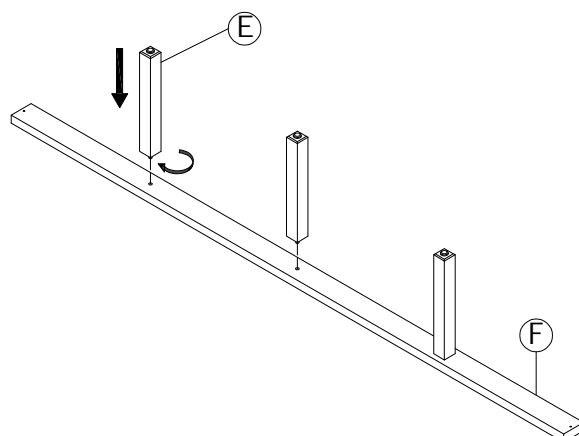

# CAMDEN PANEL FULL BED

## ASSEMBLY INSTRUCTIONS



### STEP 5:

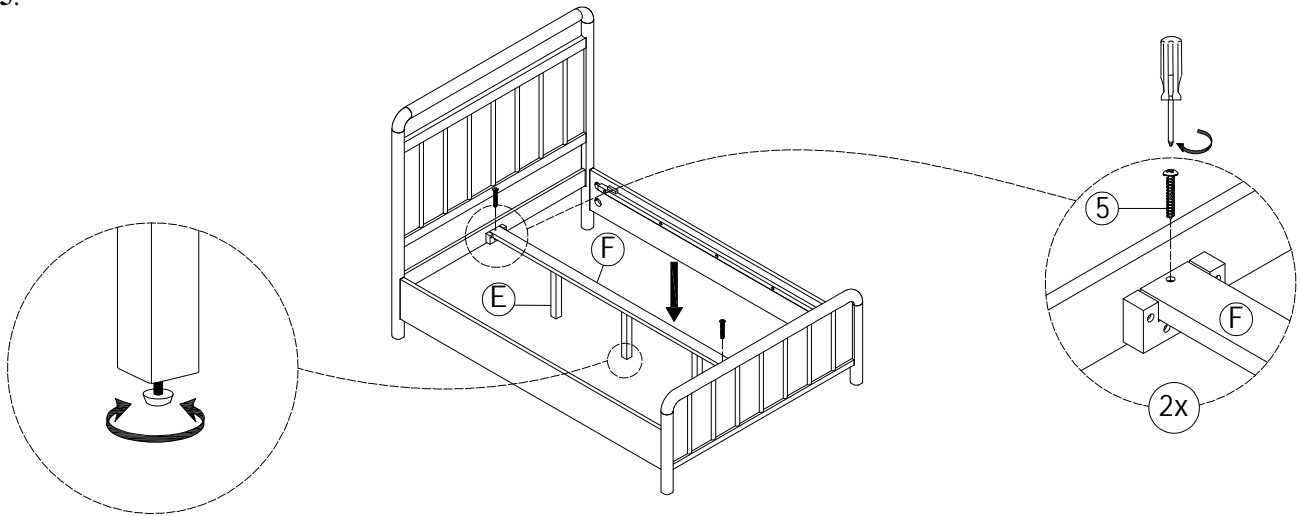

### STEP 6:

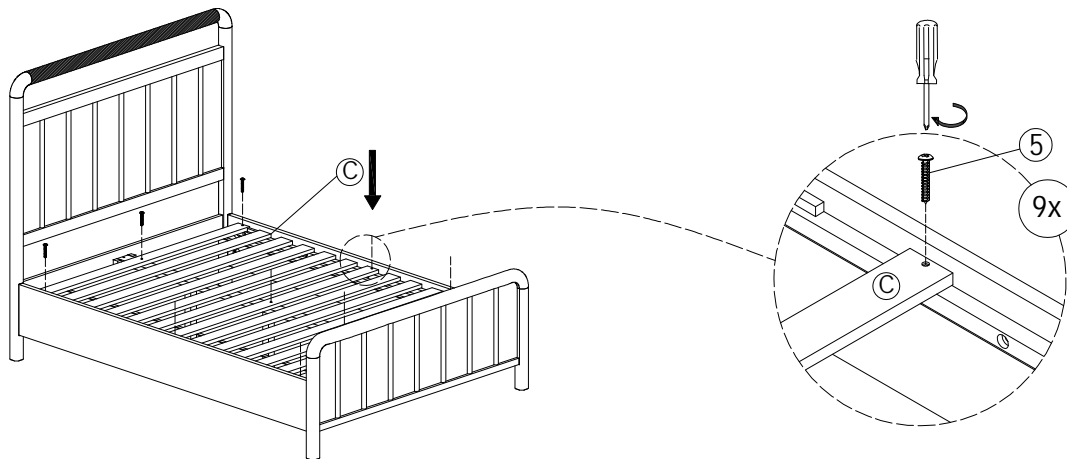

### STEP 7:

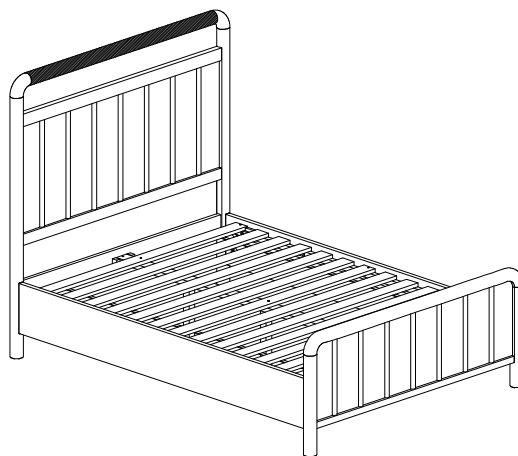

ASSEMBLY COMPLETE

#### INSTRUCTIONS FOR ADJUSTING LEVELERS:

Position the bed in your space and locate the leveler under each support leg.

Turn the leveler counter-clockwise to extend the leveler and clockwise to retract it.

Adjust each leveler until each support leg is applying equal, upward pressure on the support slat.

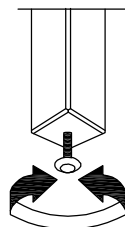

#### MAINTENANCE INSTRUCTIONS:

- Periodically check all fittings and tighten if necessary, as they can loosen over time.
- Always remove box spring and mattress before moving the bed.
- Lift the bed when moving it. Dragging the bed can damage the center support.
- Readjust levelers after moving the bed.

# CAMDEN PANEL FULL BED

## ASSEMBLY INSTRUCTIONS

### APPENDIX A: ADJUSTABLE MATTRESS BASE ASSEMBLY SUPPLEMENT



AN ADJUSTABLE MATTRESS BASE IS A FREESTANDING MATTRESS SUPPORT THAT SITS WITHIN THE PERIMETER OF THE BED FRAME.

IF USING THIS BED FRAME WITH A STANDARD BOX SPRING OR FOUNDATION THESE INSTRUCTIONS DO NOT APPLY.

PRE-ASSEMBLED SIDE RAIL CLEATS OBSTRUCT ADJUSTABLE BASE INSTALLATION AND OPERATION. FOLLOW THESE INSTRUCTIONS TO REMOVE THEM.

THE FOLLOWING PARTS ARE NOT REQUIRED FOR ADJUSTABLE MATTRESS BASE INSTALLATION:

C. SLAT ROLL	:1 SET	5. WOOD SCREW (4x30mm)	:11 PCS
E. SLAT SUPPORT LEG	:3 PCS		
F. CENTER SLAT SUPPORT	:1 PC		

#### STEP 1:

USE ALLEN KEY (4) IN BOX #2 TO UNSCREW ALLEN BOLTS AND REMOVE PRE-ASSEMBLED SIDE RAIL CLEATS.

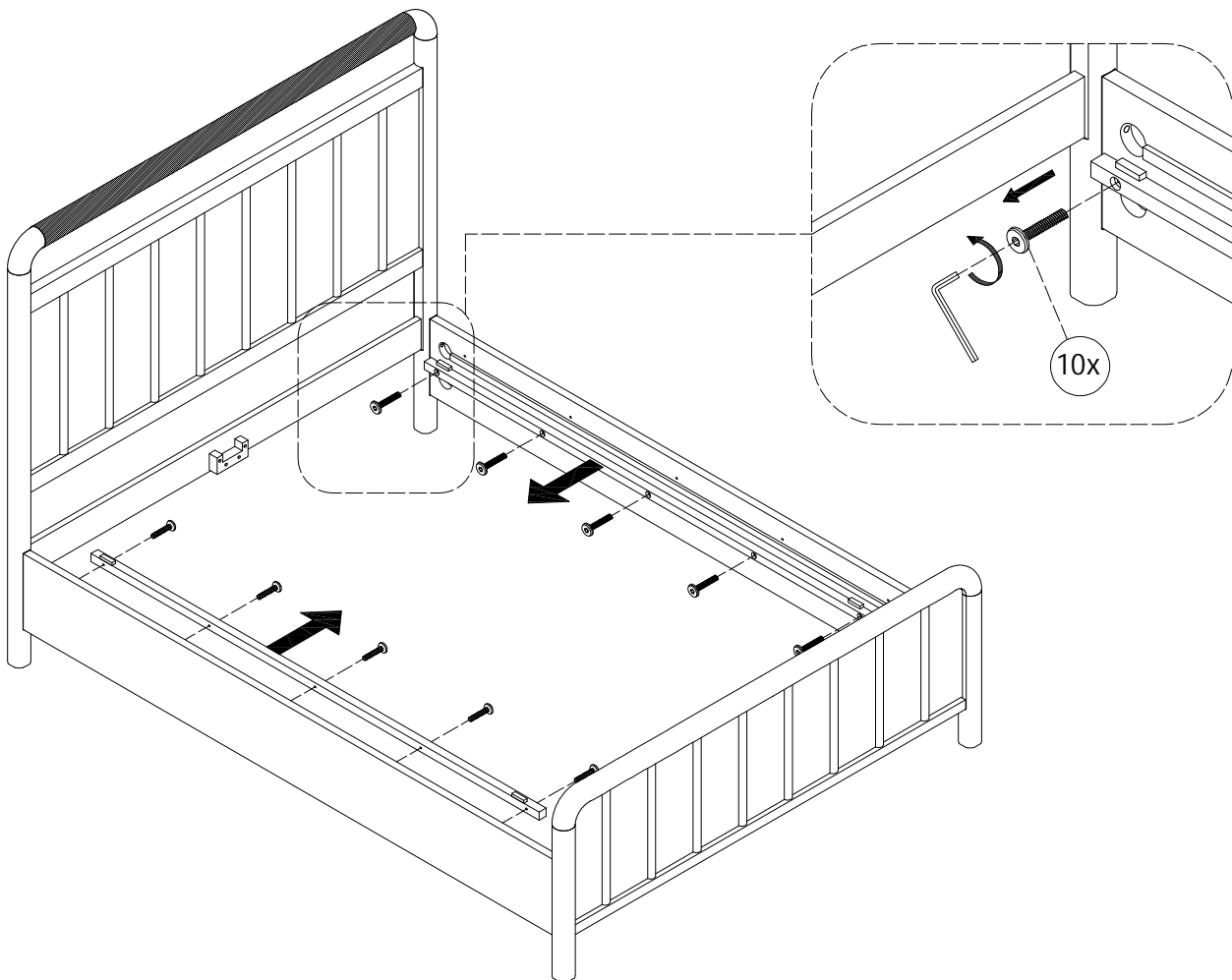

NOTE: YOU MAY WISH TO RETAIN UNUSED PARTS IF IN THE FUTURE YOU INTEND TO USE THE BED FRAME WITH A STANDARD BOX SPRING OR FOUNDATION.

# CAMDEN PANEL QUEEN BED

## ASSEMBLY INSTRUCTIONS





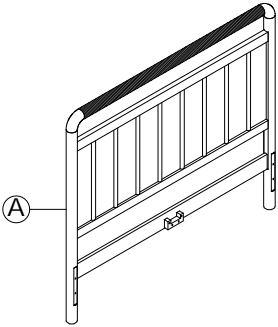
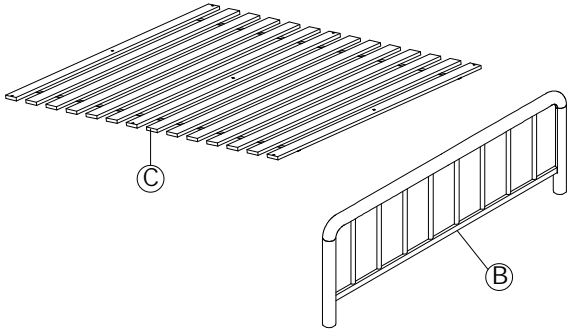
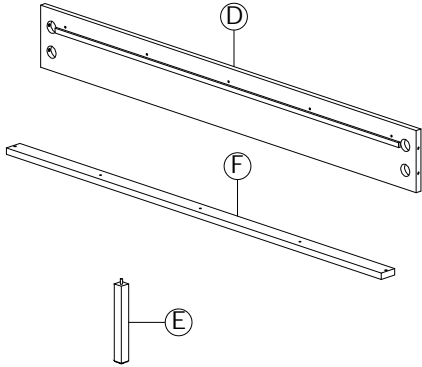

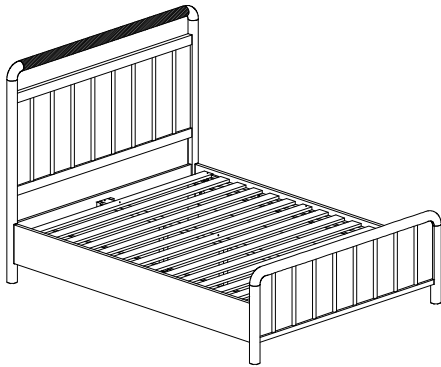

### PARTS PACKING CONFIGURATIONS

<b>BOX #1:</b> A. HEADBOARD 1 PC 	<b>BOX #2:</b> B. FOOTBOARD 1 PC C. SLAT ROLL 1 SET 	<b>BOX #3:</b> D. SIDE RAILS 2 PCS E. SLAT SUPPORT LEG 3 PCS F. CENTER SLAT SUPPORT 1 PC 
---	---	--

### FULLY ASSEMBLED



### HARDWARE KIT PACKED IN BOX #2

No.	Description	Image	Quantity
1	THREADED BOLT (8x90mm)		8 PCS
2	HALF MOON WASHER (7x14x27mm)		8 PCS
3	HEX NUT (M8)		8 PCS
4	ALLEN KEY (4mm)		1 PC
5	WOOD SCREW (4x30mm)		11 PCS
6	WRENCH (13mm)		1 PC

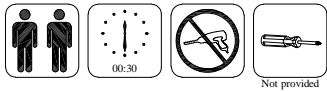

### STEP 1:

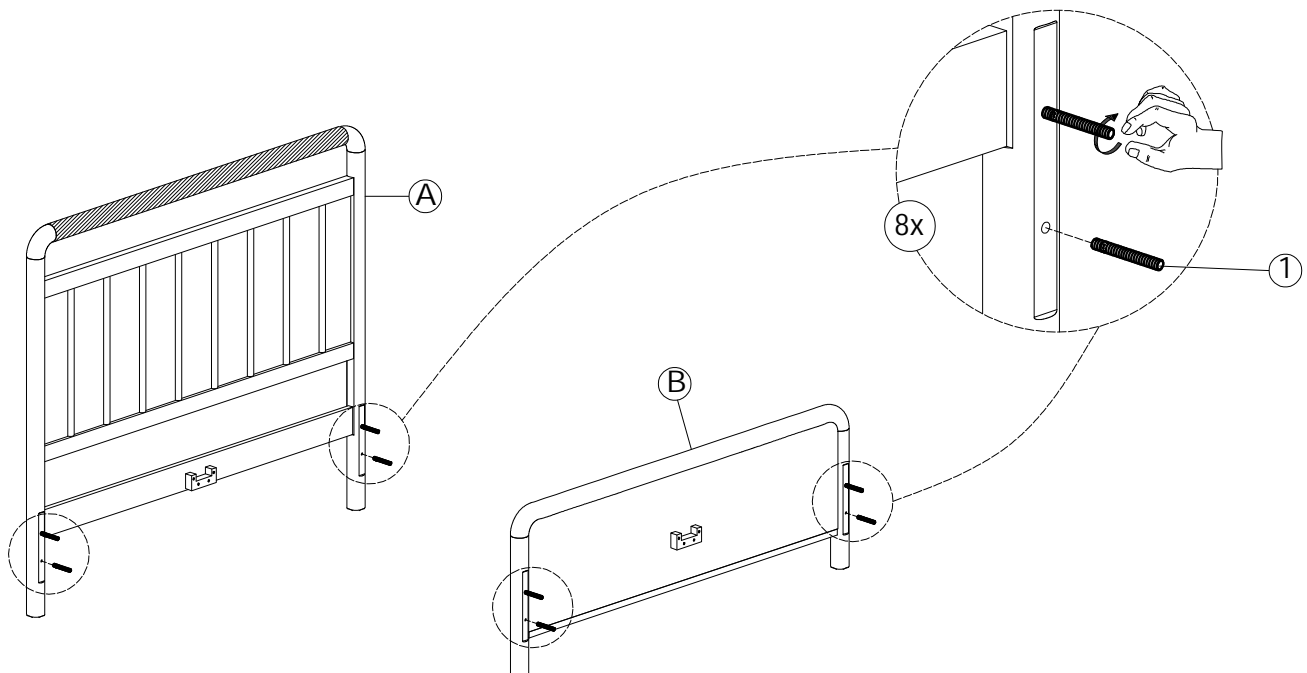

# CAMDEN PANEL QUEEN BED

## ASSEMBLY INSTRUCTIONS



### STEP 2:

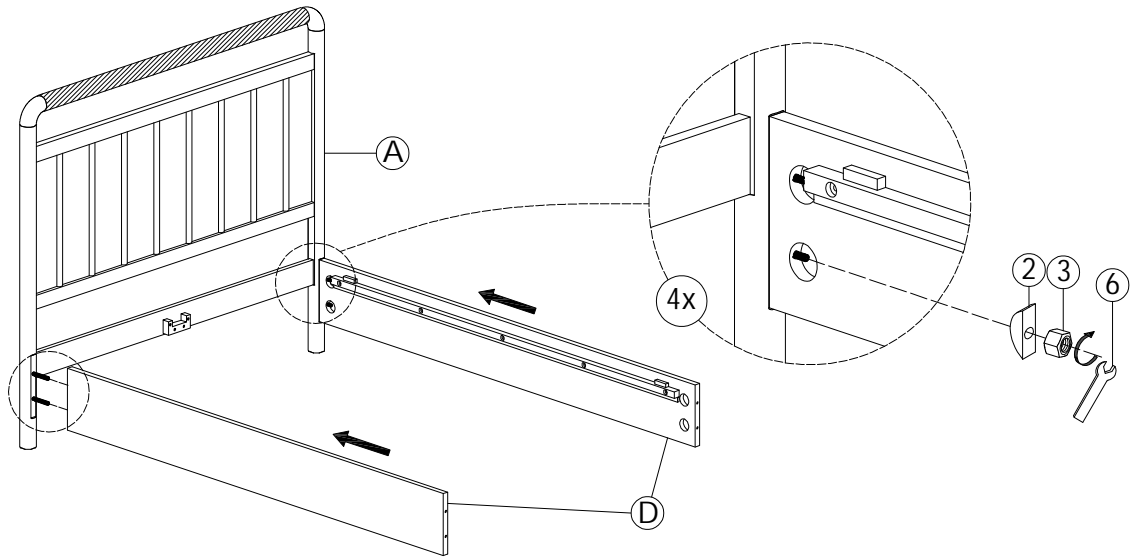

### STEP 3:

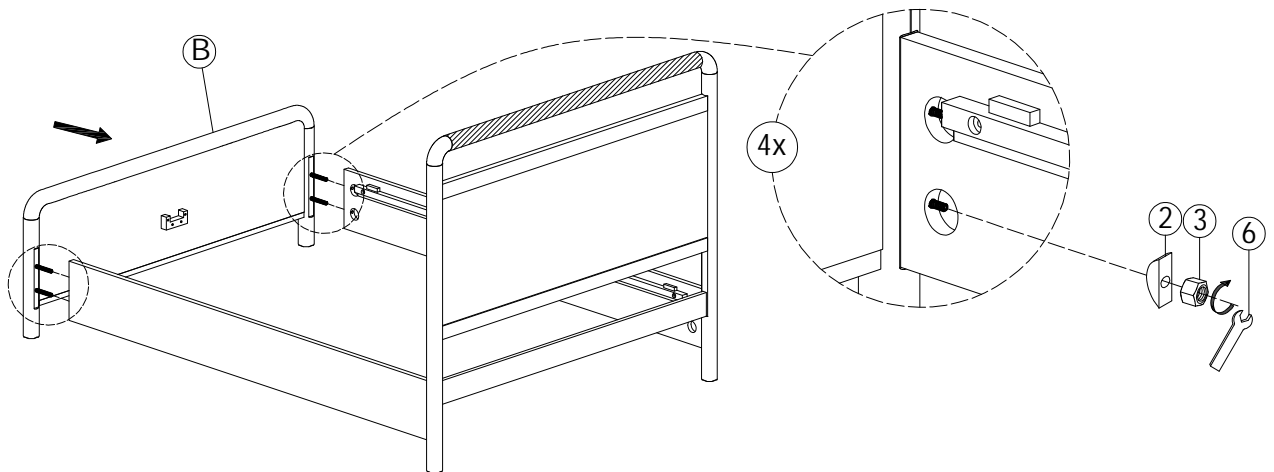

### STOP

- IF USING BED WITH AN ADJUSTABLE MATTRESS BASE, SKIP STEPS 4, 5, 6 & 7 AND REFERENCE APPENDIX A: ADJUSTABLE MATTRESS BASE ASSEMBLY SUPPLEMENT.
- IF USING BED FRAME WITH STANDARD BOX SPRING OR FOUNDATION, CONTINUE TO STEP 4

### STEP 4:

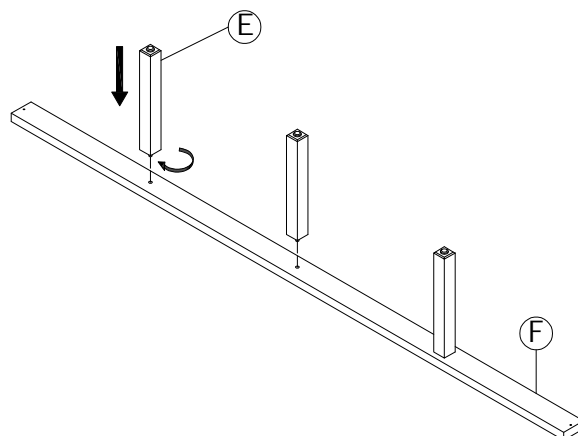

# CAMDEN PANEL QUEEN BED

## ASSEMBLY INSTRUCTIONS



### STEP 5:

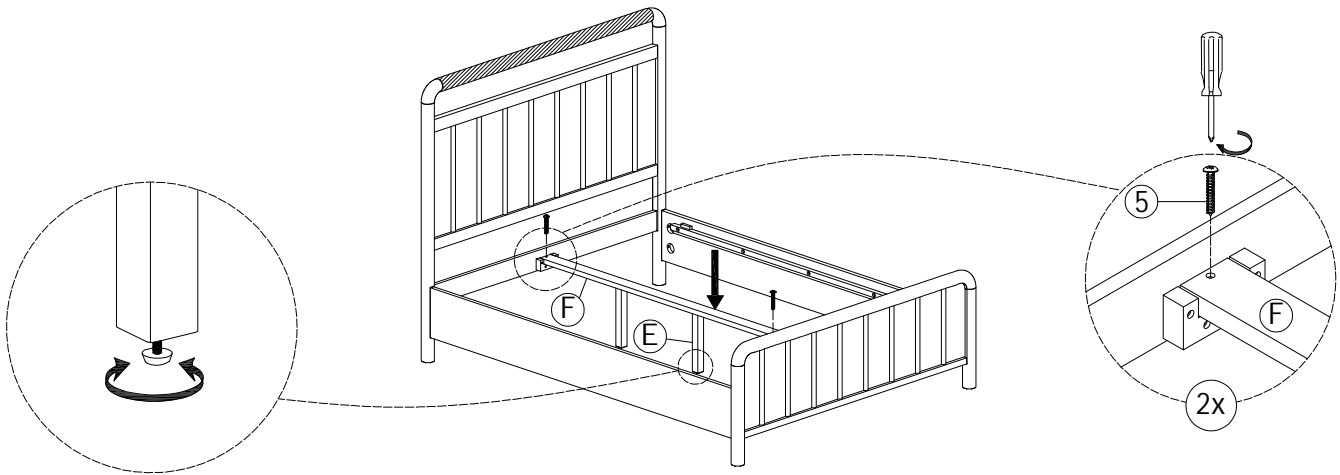

### STEP 6:

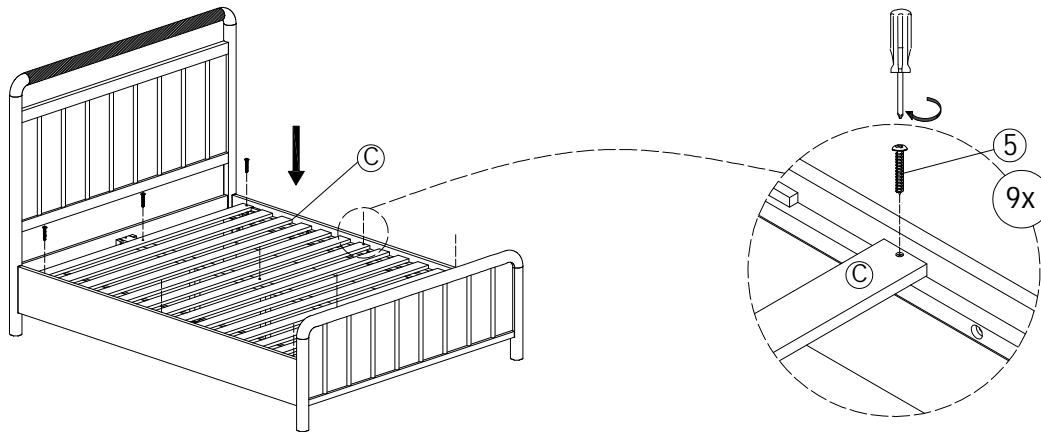

### STEP 7:

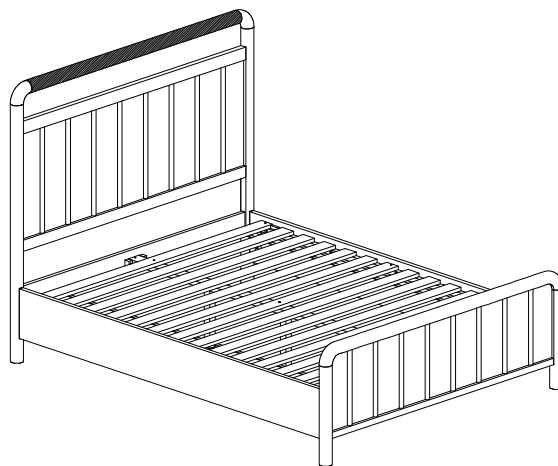

ASSEMBLY COMPLETE

#### INSTRUCTIONS FOR ADJUSTING LEVELERS:

Position the bed in your space and locate the leveler under each support leg.

Turn the leveler counter-clockwise to extend the leveler and clockwise to retract it.

Adjust each leveler until each support leg is applying equal, upward pressure on the support slat.

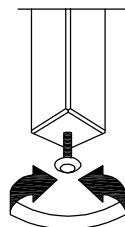

#### MAINTENANCE INSTRUCTIONS:

- Periodically check all fittings and tighten if necessary, as they can loosen over time.
- Always remove box spring and mattress before moving the bed.
- Lift the bed when moving it. Dragging the bed can damage the center support.
- Readjust levelers after moving the bed.

# CAMDEN PANEL QUEEN BED

## ASSEMBLY INSTRUCTIONS



### APPENDIX A: ADJUSTABLE MATTRESS BASE ASSEMBLY SUPPLEMENT

AN ADJUSTABLE MATTRESS BASE IS A FREESTANDING MATTRESS SUPPORT THAT SITS WITHIN THE PERIMETER OF THE BED FRAME.

IF USING THIS BED FRAME WITH A STANDARD BOX SPRING OR FOUNDATION THESE INSTRUCTIONS DO NOT APPLY.

PRE-ASSEMBLED SIDE RAIL CLEATS OBSTRUCT ADJUSTABLE BASE INSTALLATION AND OPERATION. FOLLOW THESE INSTRUCTIONS TO REMOVE THEM.

THE FOLLOWING PARTS ARE NOT REQUIRED FOR ADJUSTABLE MATTRESS BASE INSTALLATION:

C. SLAT ROLL	:1 SET	5. WOOD SCREW (4x30mm)	:11 PCS
E. SLAT SUPPORT LEG	:3 PCS		
F. CENTER SLAT SUPPORT	:1 PC		

#### STEP 1:

USE ALLEN KEY (4) IN BOX #2 TO UNSCREW ALLEN BOLTS AND REMOVE PRE-ASSEMBLED SIDE RAIL CLEATS.

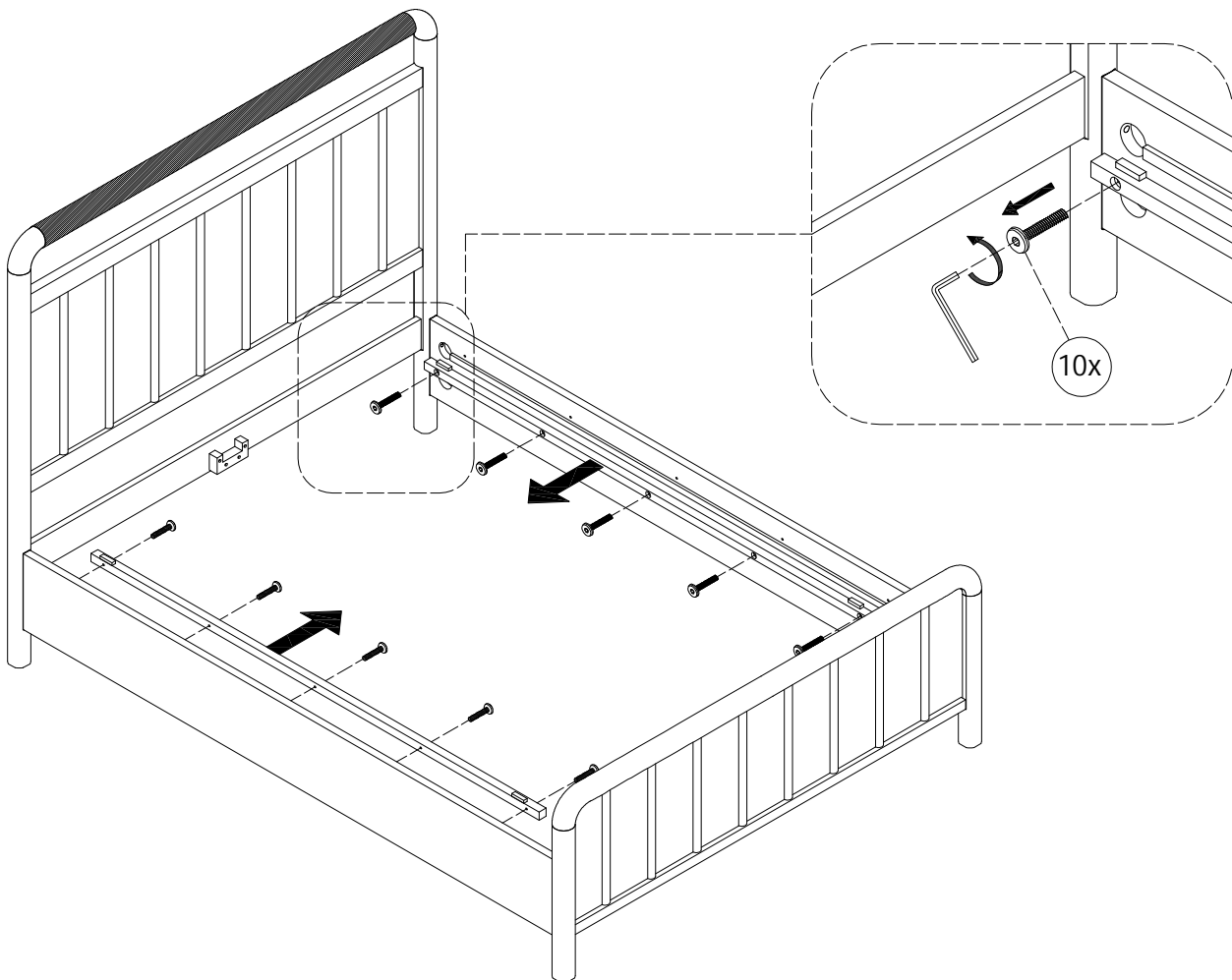

NOTE: YOU MAY WISH TO RETAIN UNUSED PARTS IF IN THE FUTURE YOU INTEND TO USE THE BED FRAME WITH A STANDARD BOX SPRING OR FOUNDATION.



# CAMDEN PANEL CAL. KING BED

## ASSEMBLY INSTRUCTIONS



### PARTS PACKING CONFIGURATIONS

**BOX #1:**  
A. HEADBOARD 1 PC

**BOX #2:**  
B. FOOTBOARD 1 PC  
C. SLAT ROLL 1 SET

**BOX #3:**  
D. SIDE RAILS 2 PCS  
E. SLAT SUPPORT LEG 6 PCS  
F. CENTER SLAT SUPPORT 2 PCS  
G. MATTRESS SPACER 2 PCS

### FULLY ASSEMBLED

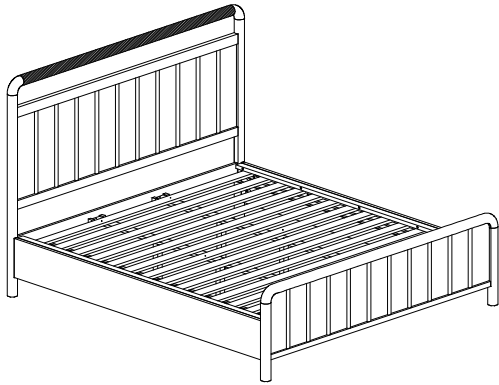

### HARDWARE KIT PACKED IN BOX #2

No.	Description	Image	Quantity
1	THREADED BOLT (8x90mm)		8 PCS
2	HALF MOON WASHER (7x14x27mm)		8 PCS
3	HEX NUT (M8)		8 PCS
4	ALLEN KEY (4mm)		1 PC
5	WOOD SCREW (4x30mm)		16 PCS
6	WRENCH (13mm)		1 PC
7	ALLEN BOLT (6x60mm)		10 PCS
8	SPRING WASHER (M6)		10 PCS
9	FLAT WASHER (M6)		10 PCS



### STEP 1:

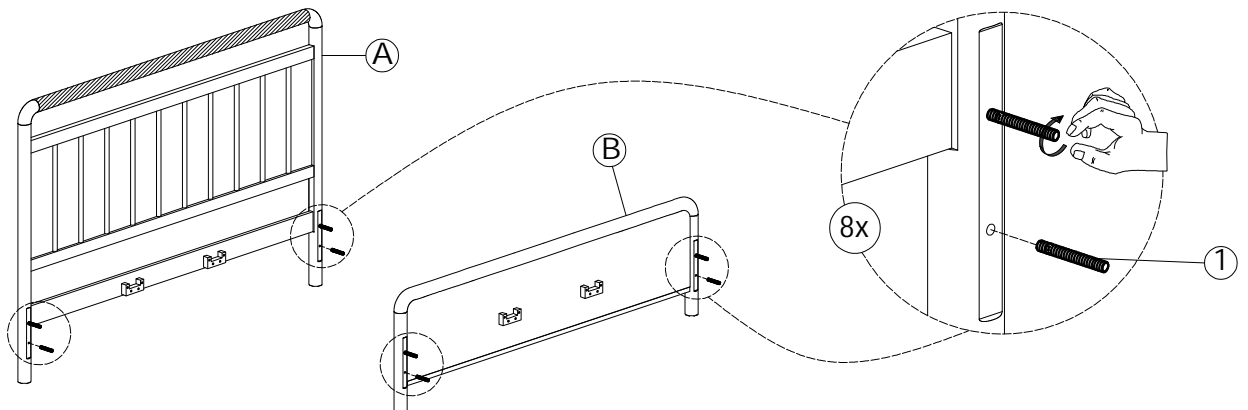

# CAMDEN PANEL CAL. KING BED

## ASSEMBLY INSTRUCTIONS



### STEP 2:

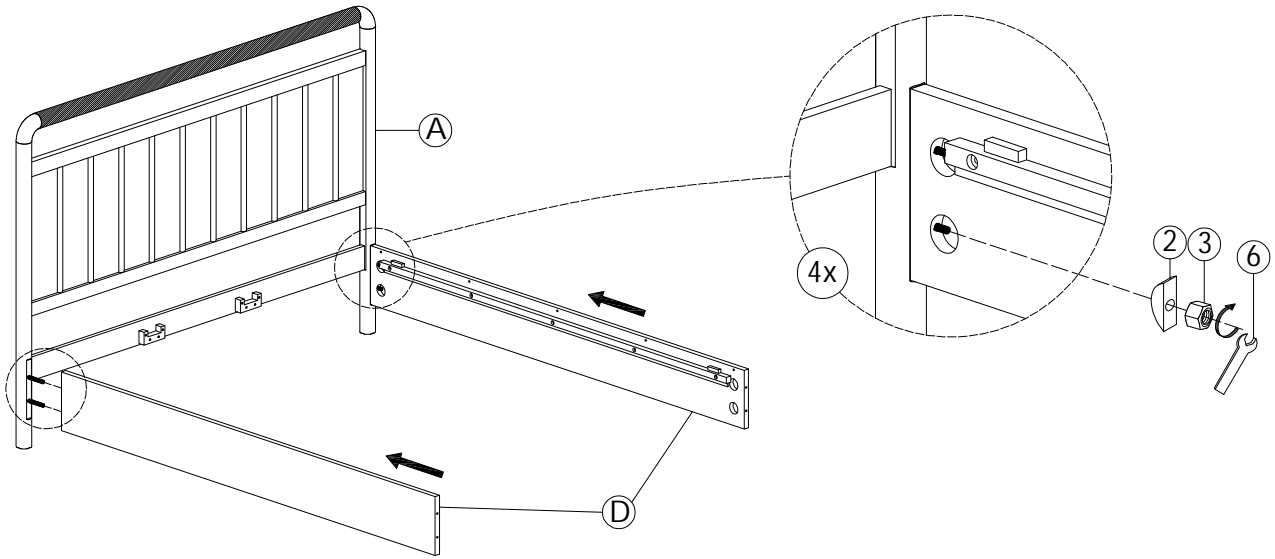

### STEP 3:

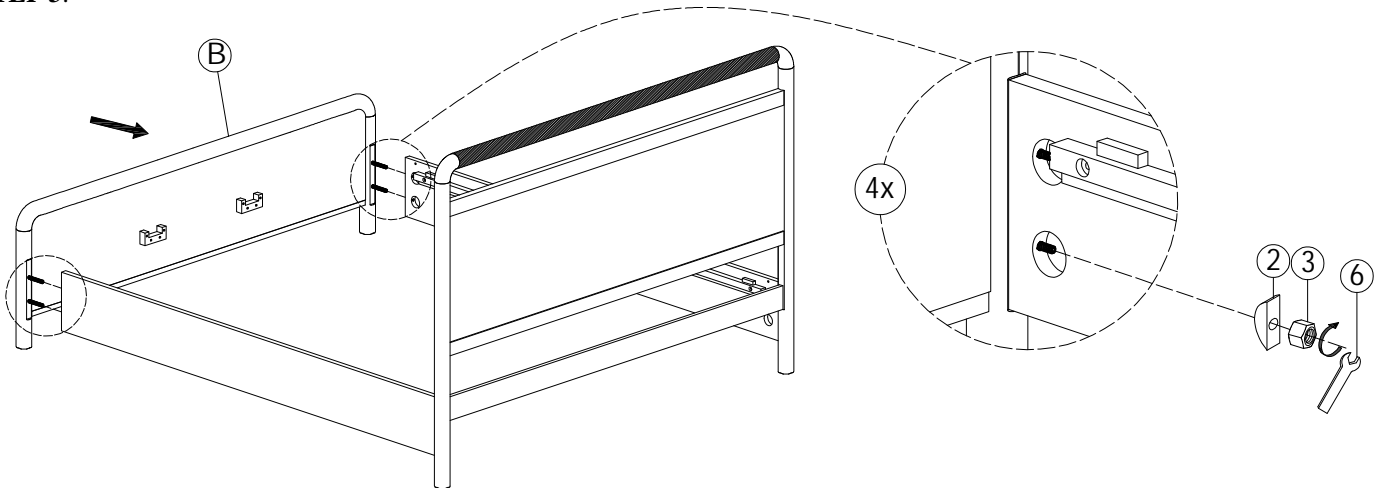

### STOP

- IF USING BED WITH AN ADJUSTABLE MATTRESS BASE, SKIP STEPS 4, 5, 6 & 7 AND REFERENCE APPENDIX A: ADJUSTABLE MATTRESS BASE ASSEMBLY SUPPLEMENT.
- IF USING BED FRAME WITH STANDARD BOX SPRING OR FOUNDATION, CONTINUE TO STEP 4

### STEP 4:

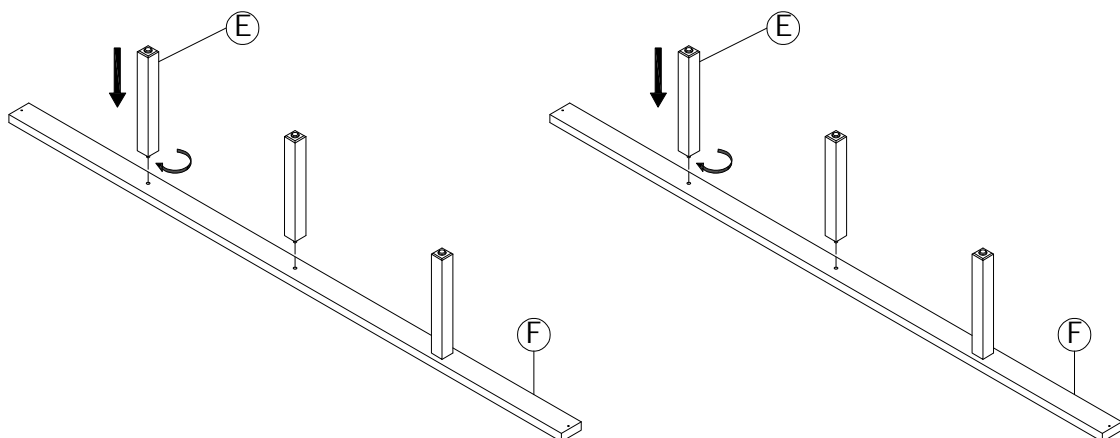

# CAMDEN PANEL CAL. KING BED

## ASSEMBLY INSTRUCTIONS



### STEP 5:

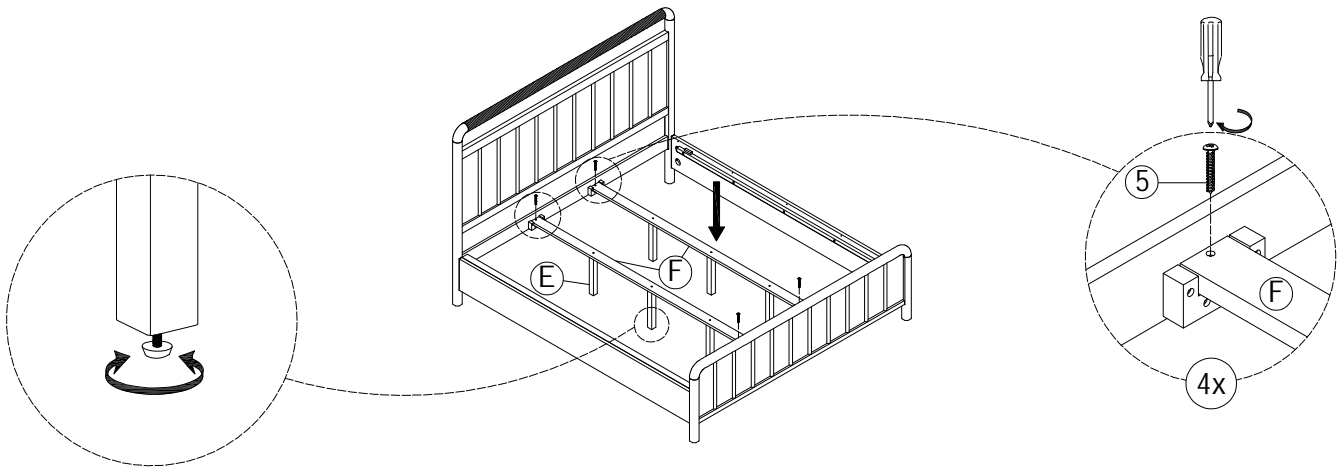

### STEP 6:

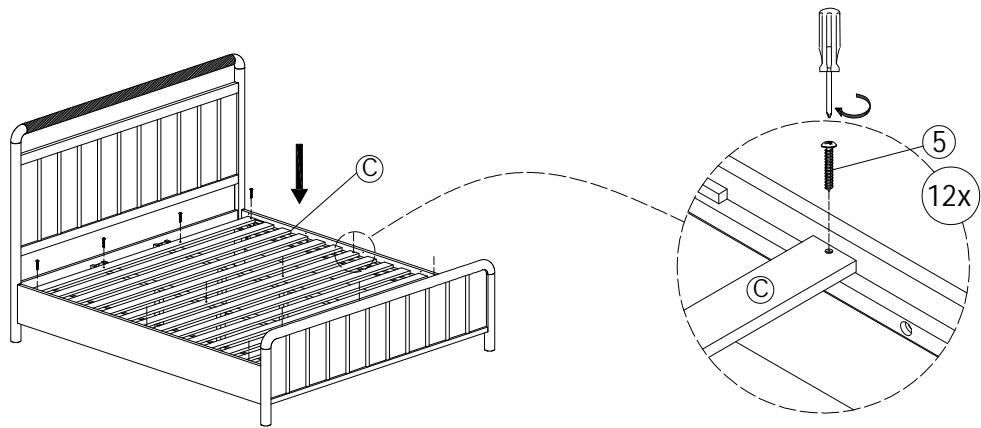

### STEP 7:

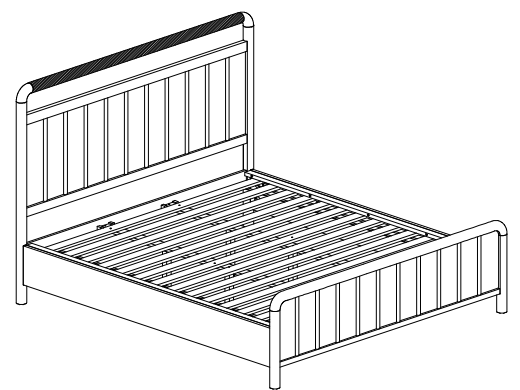
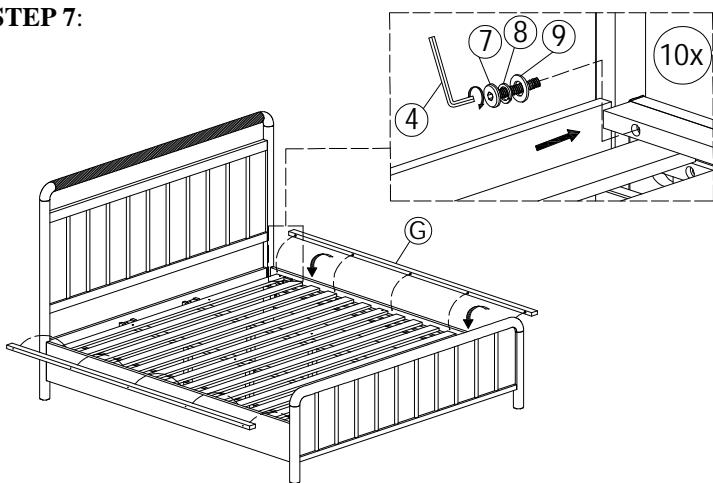

ASSEMBLY COMPLETE

### INSTRUCTIONS FOR ADJUSTING LEVELERS:

Position the bed in your space and locate the leveler under each support leg.

Turn the leveler counter-clockwise to extend the leveler and clockwise to retract it.

Adjust each leveler until each support leg is applying equal, upward pressure on the support slat.

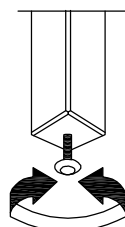

### MAINTENANCE INSTRUCTIONS:

- Periodically check all fittings and tighten if necessary, as they can loosen over time.
- Always remove box spring and mattress before moving the bed.
- Lift the bed when moving it. Dragging the bed can damage the center support.
- Readjust levelers after moving the bed.

# CAMDEN PANEL CAL. KING BED

## ASSEMBLY INSTRUCTIONS

### APPENDIX A: ADJUSTABLE MATTRESS BASE ASSEMBLY SUPPLEMENT



AN ADJUSTABLE MATTRESS BASE IS A FREESTANDING MATTRESS SUPPORT THAT SITS WITHIN THE PERIMETER OF THE BED FRAME.

IF USING THIS BED FRAME WITH A STANDARD BOX SPRING OR FOUNDATION THESE INSTRUCTIONS DO NOT APPLY.

PRE-ASSEMBLED SIDE RAIL CLEATS OBSTRUCT ADJUSTABLE BASE INSTALLATION AND OPERATION. FOLLOW THESE INSTRUCTIONS TO REMOVE THEM.

THE FOLLOWING PARTS ARE NOT REQUIRED FOR ADJUSTABLE MATTRESS BASE INSTALLATION:

C. SLAT ROLL	:1 SET	5. WOOD SCREW (4x30mm)	:16 PCS
E. SLAT SUPPORT LEG	:6 PCS	7. ALLEN BOLT (6x60mm)	:10 PCS
F. CENTER SLAT SUPPORT	:2 PCS	8. SPRING WASHER (M6)	:10 PCS
G. MATTRESS SPACER	:2 PCS	9. FLAT WASHER (M6)	:10 PCS

#### STEP 1:

USE ALLEN KEY (4) IN BOX #2 TO UNSCREW ALLEN BOLTS AND REMOVE PRE-ASSEMBLED SIDE RAIL CLEATS.

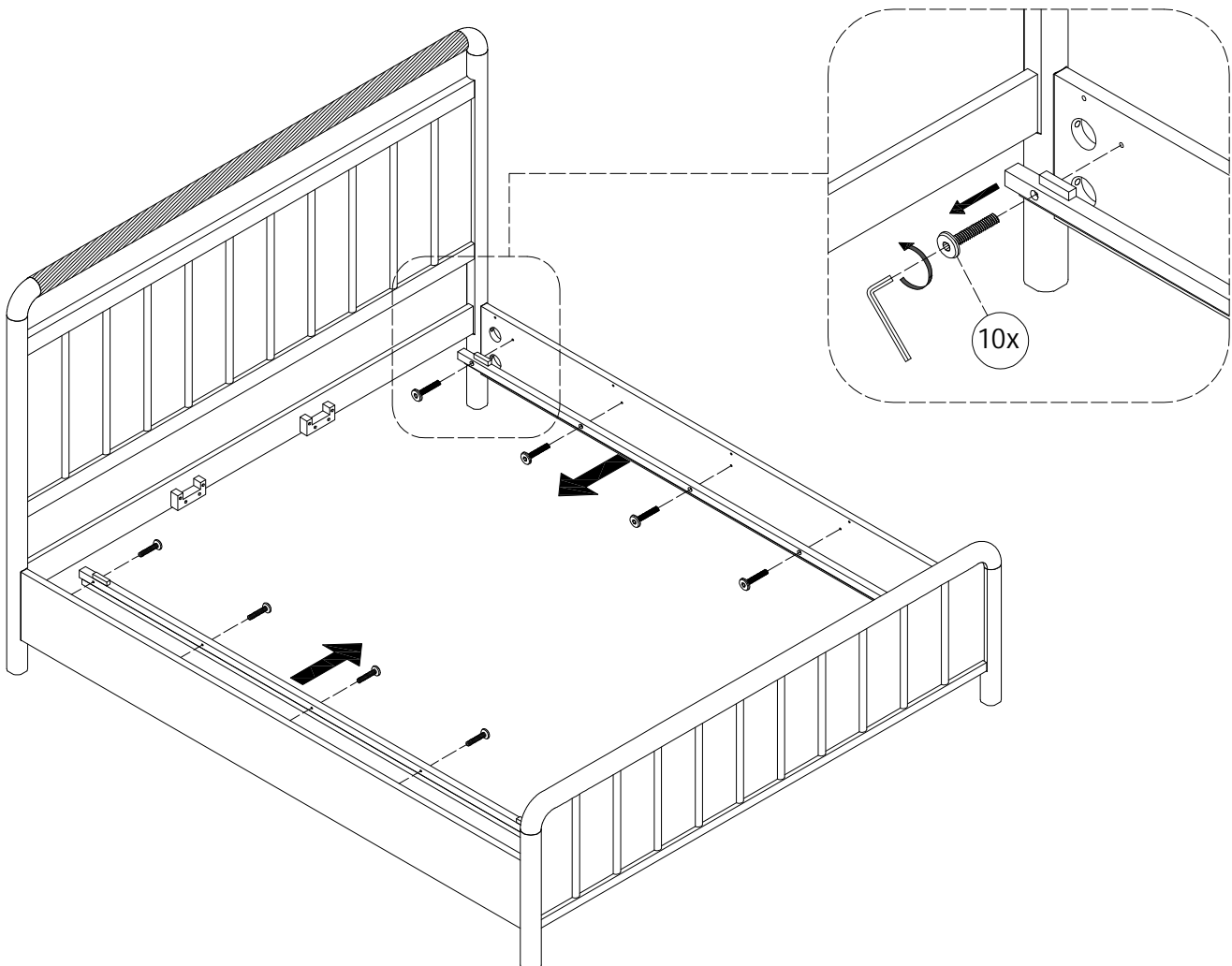

NOTE: YOU MAY WISH TO RETAIN UNUSED PARTS IF IN THE FUTURE YOU INTEND TO USE THE BED FRAME WITH A STANDARD BOX SPRING OR FOUNDATION.

# CAMDEN PANEL KING BED

## ASSEMBLY INSTRUCTIONS



### PARTS PACKING CONFIGURATIONS

**BOX #1:**  
A. HEADBOARD 1 PC

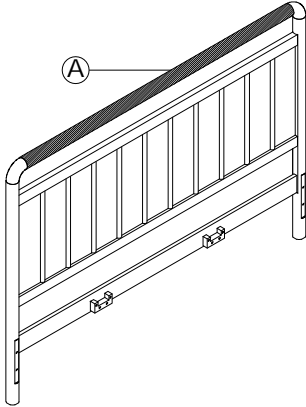

**BOX #2:**  
B. FOOTBOARD 1 PC  
C. SLAT ROLL 1 SET

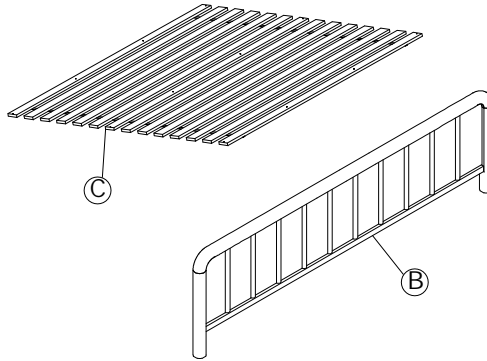

**BOX #3:**  
D. SIDE RAILS 2 PCS  
E. SLAT SUPPORT LEG 6 PCS  
F. CENTER SLAT SUPPORT 2 PCS

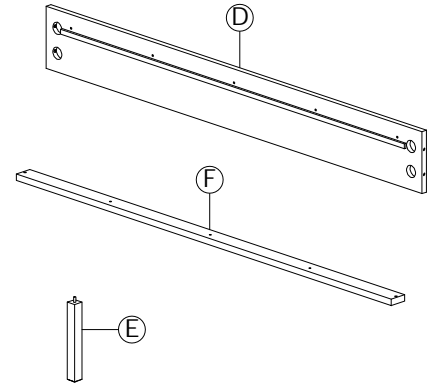

### FULLY ASSEMBLED

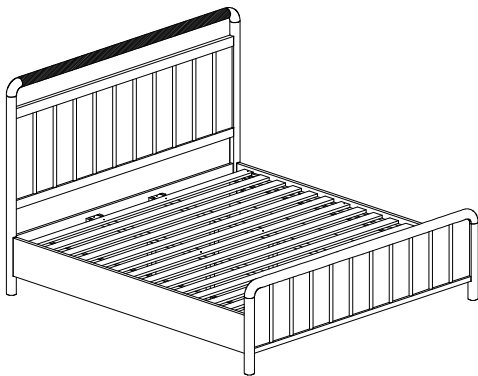

### HARDWARE KIT PACKED IN BOX #2

No.	Description	Image	Quantity
1	THREADED BOLT (8x90mm)		8 PCS
2	HALF MOON WASHER (7x14x27mm)		8 PCS
3	HEX NUT (M8)		8 PCS
4	ALLEN KEY (4mm)		1 PC
5	WOOD SCREW (4x30mm)		16 PCS
6	WRENCH (13mm)		1 PC



### STEP 1:

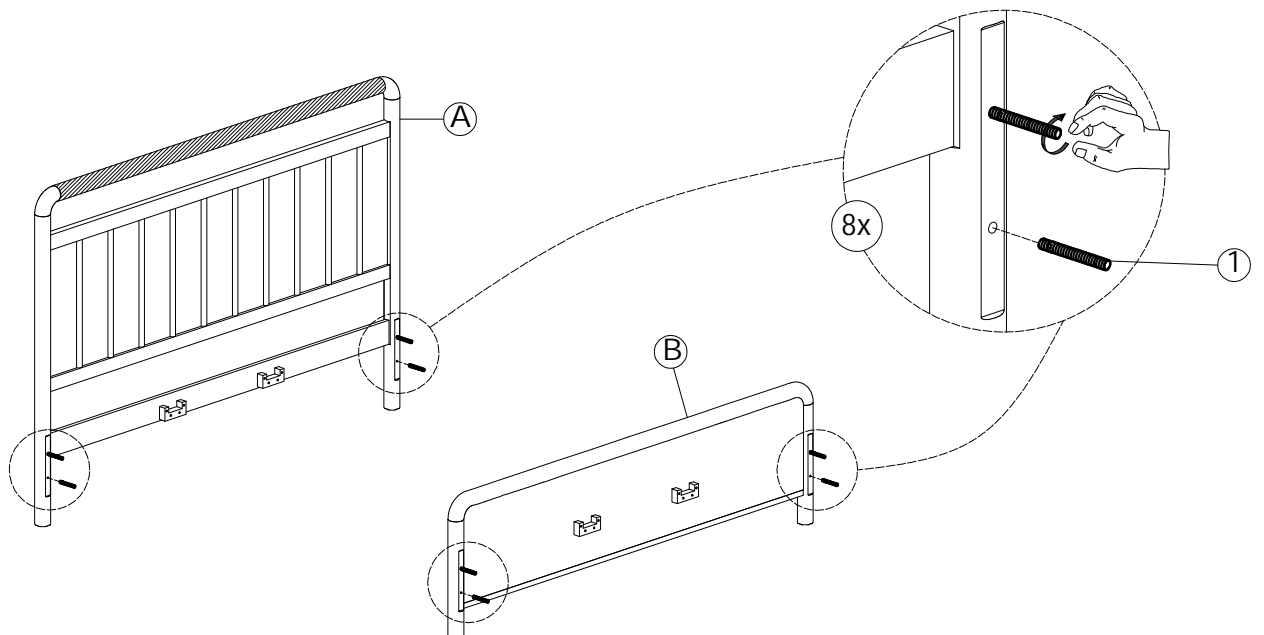

# CAMDEN PANEL KING BED

## ASSEMBLY INSTRUCTIONS



### STEP 2:

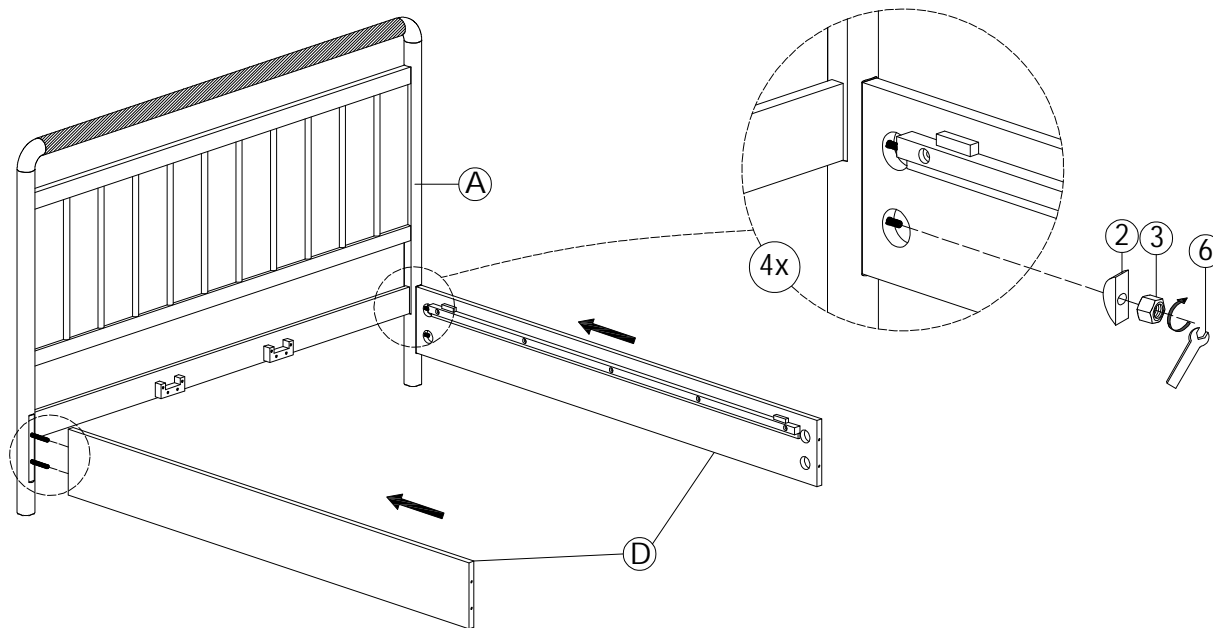

### STEP 3:

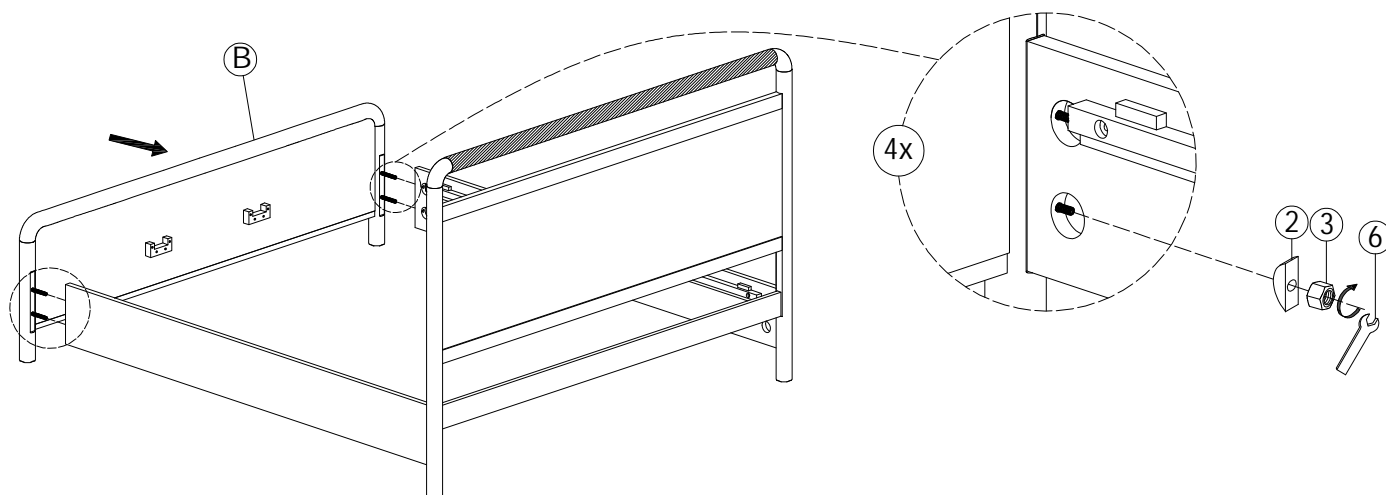

### STOP

- IF USING BED WITH AN ADJUSTABLE MATTRESS BASE, SKIP STEPS 4, 5, 6 & 7 AND REFERENCE APPENDIX A: ADJUSTABLE MATTRESS BASE ASSEMBLY SUPPLEMENT.
- IF USING BED FRAME WITH STANDARD BOX SPRING OR FOUNDATION, CONTINUE TO STEP 4

### STEP 4:

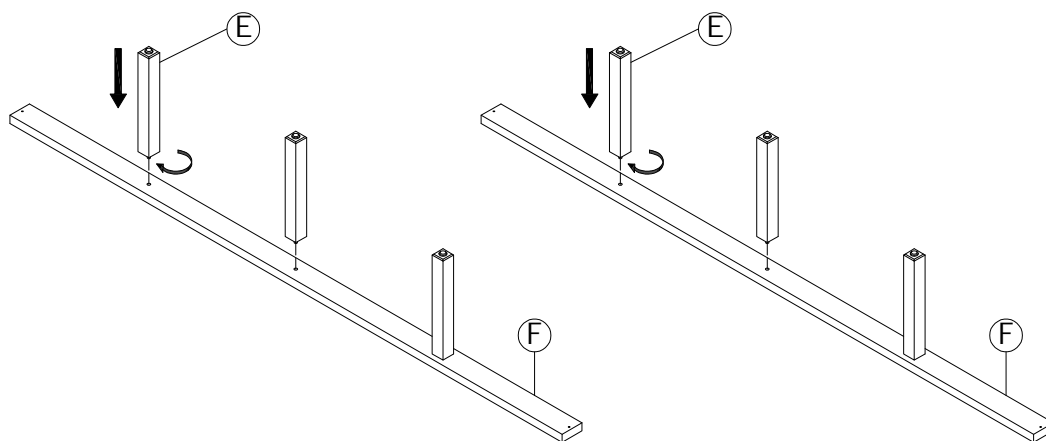

# CAMDEN PANEL KING BED

## ASSEMBLY INSTRUCTIONS



### STEP 5:

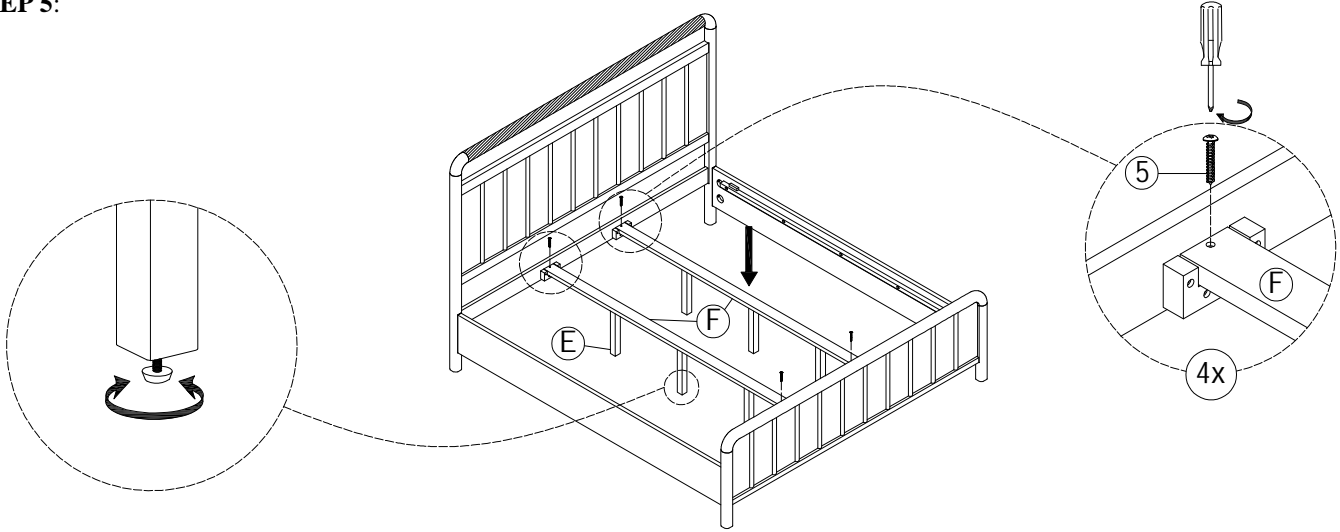

### STEP 6:

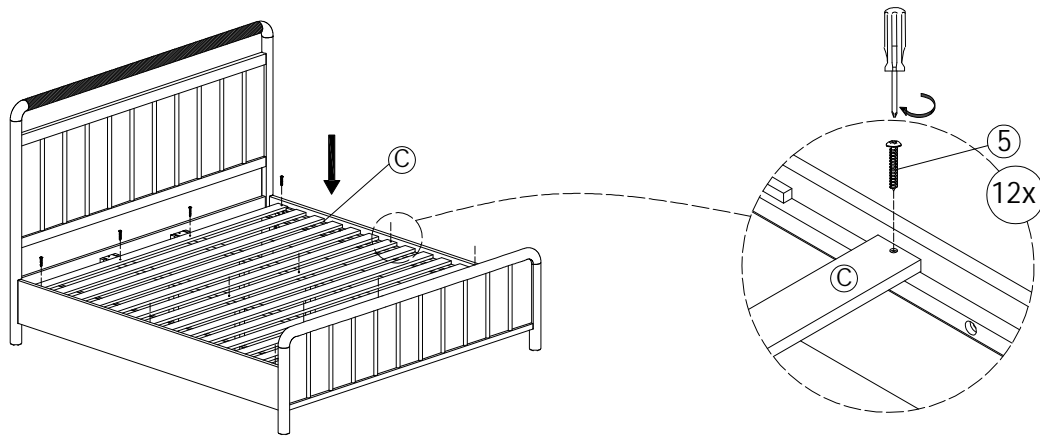

### STEP 7:

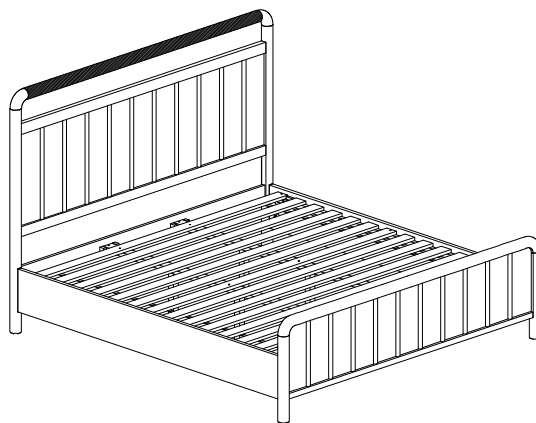

ASSEMBLY COMPLETE

#### INSTRUCTIONS FOR ADJUSTING LEVELERS:

Position the bed in your space and locate the leveler under each support leg.

Turn the leveler counter-clockwise to extend the leveler and clockwise to retract it.

Adjust each leveler until each support leg is applying equal, upward pressure on the support slat.

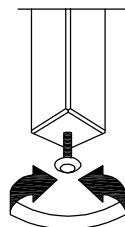

#### MAINTENANCE INSTRUCTIONS:

- Periodically check all fittings and tighten if necessary, as they can loosen over time.
- Always remove box spring and mattress before moving the bed.
- Lift the bed when moving it. Dragging the bed can damage the center support.
- Readjust levelers after moving the bed.

# CAMDEN PANEL KING BED

## ASSEMBLY INSTRUCTIONS

### APPENDIX A: ADJUSTABLE MATTRESS BASE ASSEMBLY SUPPLEMENT



AN ADJUSTABLE MATTRESS BASE IS A FREESTANDING MATTRESS SUPPORT THAT SITS WITHIN THE PERIMETER OF THE BED FRAME.

IF USING THIS BED FRAME WITH A STANDARD BOX SPRING OR FOUNDATION THESE INSTRUCTIONS DO NOT APPLY.

PRE-ASSEMBLED SIDE RAIL CLEATS OBSTRUCT ADJUSTABLE BASE INSTALLATION AND OPERATION. FOLLOW THESE INSTRUCTIONS TO REMOVE THEM.

THE FOLLOWING PARTS ARE NOT REQUIRED FOR ADJUSTABLE MATTRESS BASE INSTALLATION:

C. SLAT ROLL	:1 SET	5. WOOD SCREW (4x30mm)	:16 PCS
E. SLAT SUPPORT LEG	:6 PCS		
F. CENTER SLAT SUPPORT	:2 PCS		

#### STEP 1:

USE ALLEN KEY (4) IN BOX #2 TO UNSCREW ALLEN BOLTS AND REMOVE PRE-ASSEMBLED SIDE RAIL CLEATS.

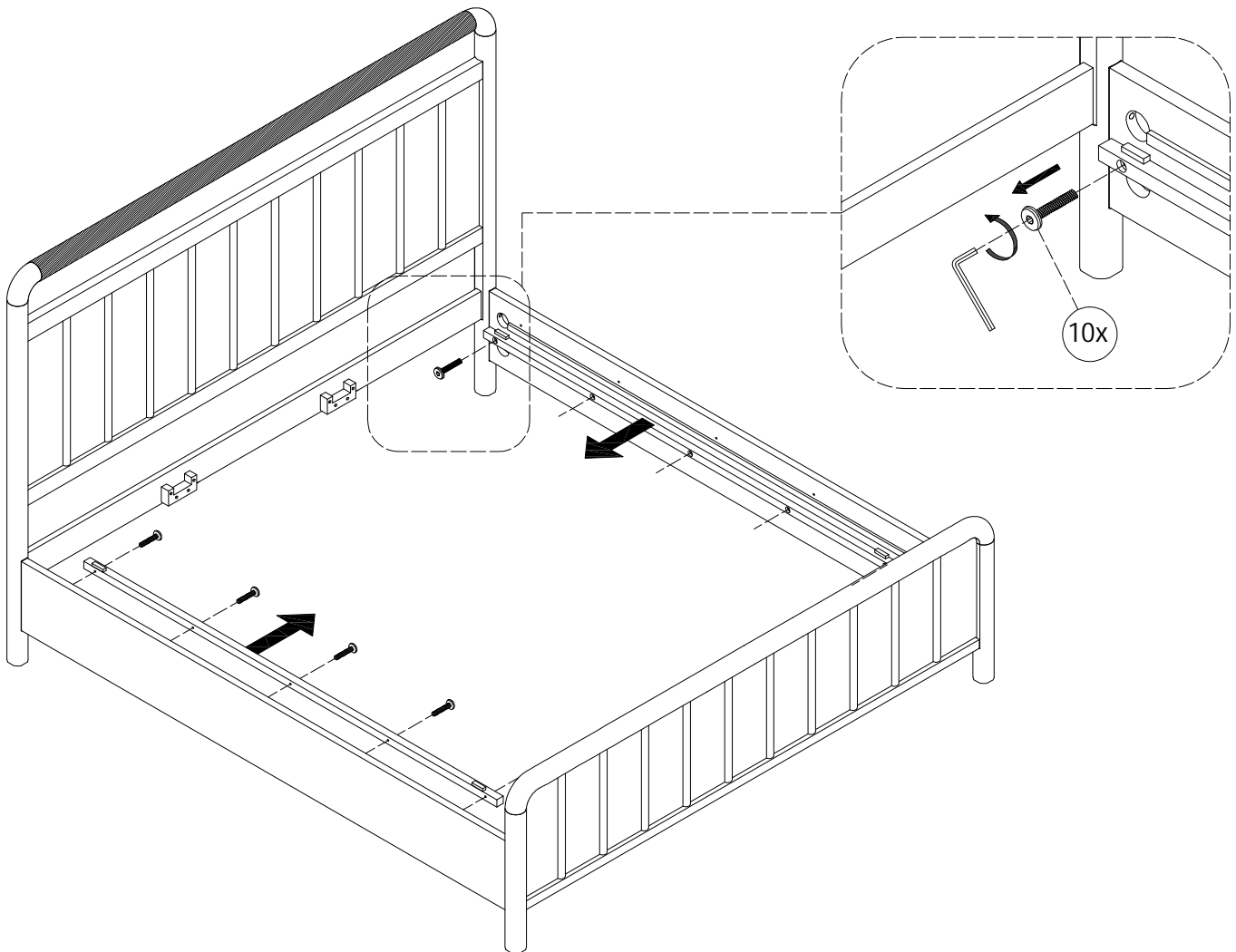

NOTE: YOU MAY WISH TO RETAIN UNUSED PARTS IF IN THE FUTURE YOU INTEND TO USE THE BED FRAME WITH A STANDARD BOX SPRING OR FOUNDATION.