

ChildLife[®]

Playsets

**3 POSITION UNIVERSAL
SWING BEAM**

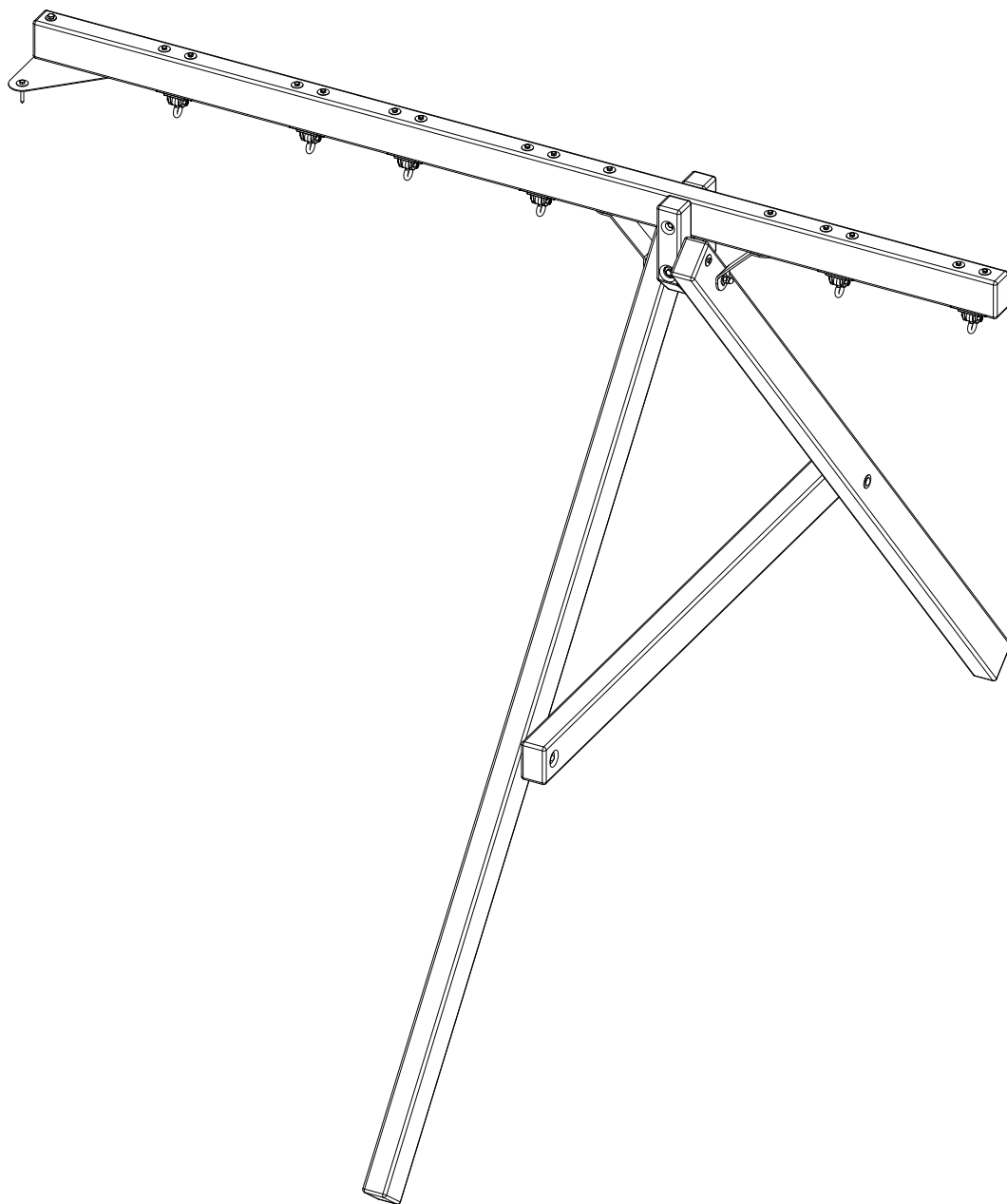

PG-MA-0027-01

INSTRUCTIONS FOR ASSEMBLY & ATTACHMENT OF ADJUSTABLE A-FRAME & HEADBEAM

PARTS LIST

ITEM	DESCRIPTION	QUANTITY
A	138" or 168" Headbeam	(1)
B	4X4 118" or 4X6 132" A-Frame Leg	(2)
C	U-Shaped Bracket	(1)
D	4X4 64" or 4X6 83 3/4" Cross Brace	(1)

Note: Depending on the model you ordered parts B and D may be 4X6 or 4X4 parts. 4X6 parts are pictured in this manual.

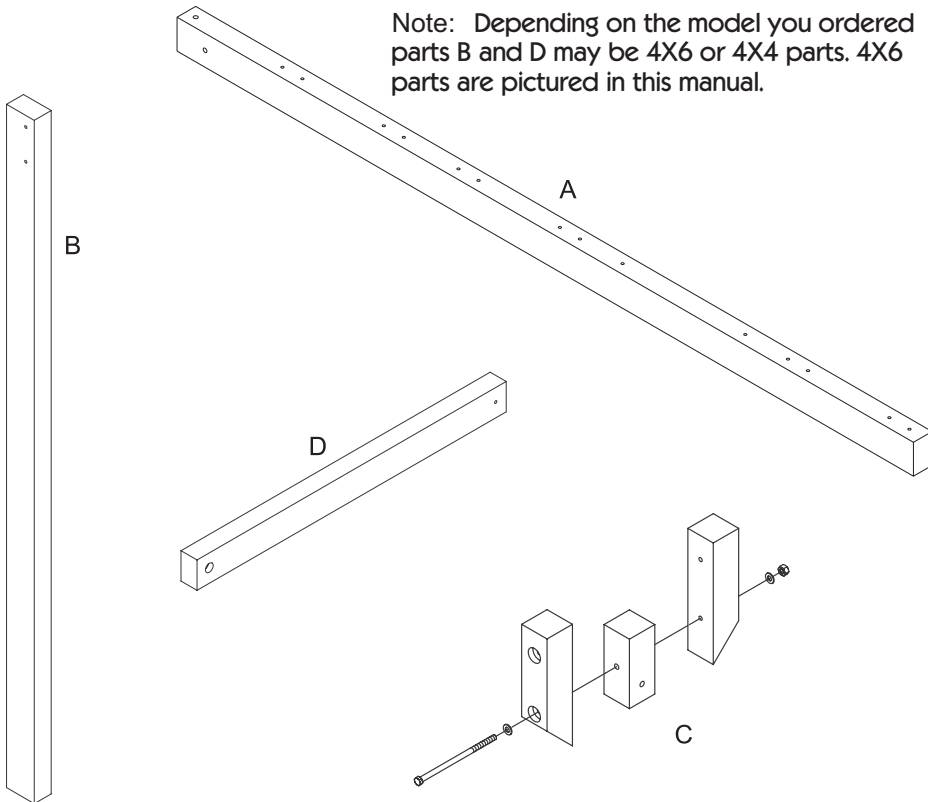

STEP 1: POSITION HEADBEAM & INSTALL HANGERS

1

PARTS NEEDED:

(1) A (138" or 168" Headbeam)

HARWARE NEEDED:

(6) DH (Ductile Swing Hanger only (4) required if 138" Headbeam)
 (12) MB2 (3/8" x 6 1/2" Machine Bolt)
 (12) FW3 (3/8" Fender Washer)
 (12) FW2 (3/8" Standard Washer)
 (12) SN1 (3/8" Loc Nut)

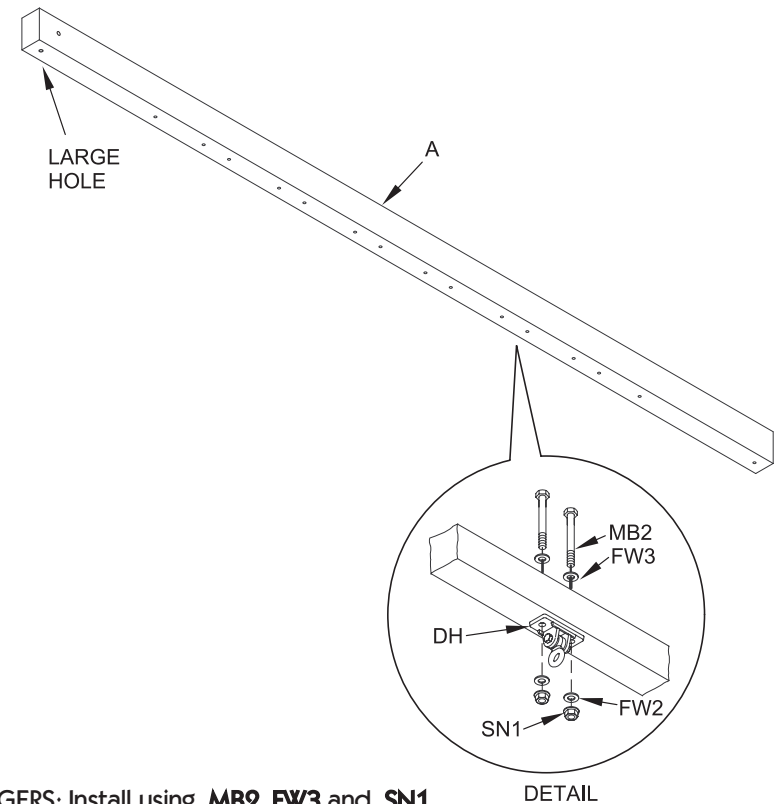

PART DH HANGERS: Install using **MB2, FW3,** and **SN1**
 (See Detail)

Now position the headbeam to where it will be attached to the playset. Place the headbeam on the ground perpendicular to the location on the playset where it attaches. The end of the headbeam with a hole through the side attaches to the playset.

STEP 2: ASSEMBLE ADJUSTABLE A-FRAME

2

PARTS NEEDED:

- (2) B (A-Frame Leg)
- (1) C (U-Shaped Bracket)

HARVARE NEEDED:

- (1) MB6 (1/2" x 12" Machine Bolt)
- (2) FW4 (1/2" Standard Washer)
- (1) SN2 (1/2" Loc Nut)
- (2) BR (Steel Support Bracket)

At the end of headbeam opposite the playset, place a part **B** and a Steel Support Brace (**BR**) on each side of part **C** as shown. Bolt together as shown using **MB6**, **FW4** and **SN2**. **DO NOT TIGHTEN COMPLETELY.**

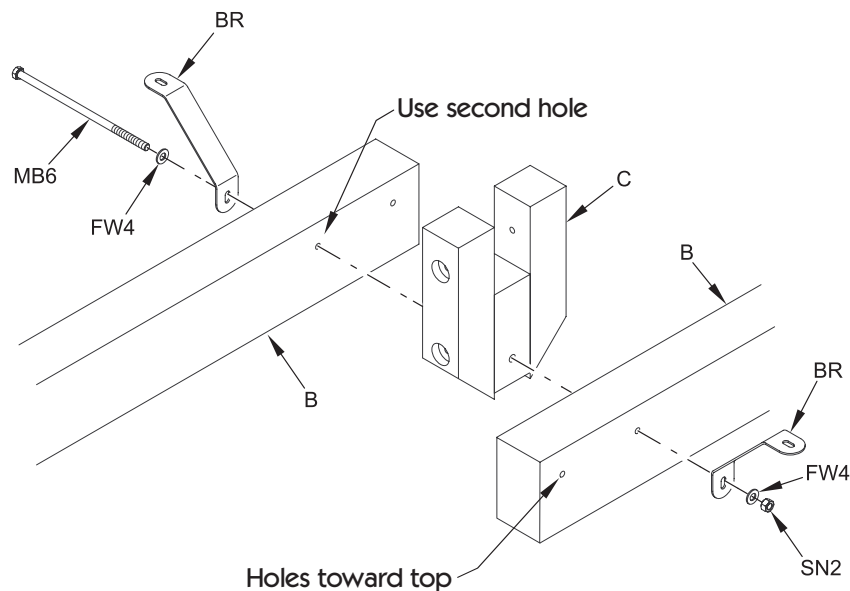

STEP 3: ATTACH HEADBEAM TO A-FRAME

3

HARVARE NEEDED:

- (2) MB2 (3/8" x 6 1/2" Machine Bolt)
- (2) FW2 (3/8" Standard Washer)
- (4) FW3 (3/8" Fender Washer)
- (2) SN1 (3/8" Loc Nut)
- (2) LS4 (4 1/2" Lag Screw)

Place the headbeam into the U-Shaped Bracket part **C** of the Step 2 assembly and line up the steel support braces to the two single holes in the headbeam spaced 23 1/4" apart (49" apart if your set has a mini-deck) and attach using **MB2**, **FW3**, **FW2** and **SN1**. When the headbeam is sitting flat in the U-bracket, attach with the **LS4** and **FW3** into the headbeam from each side. (You may need to prop up the end of the headbeam 6" for it to lay flat in the U-bracket.)

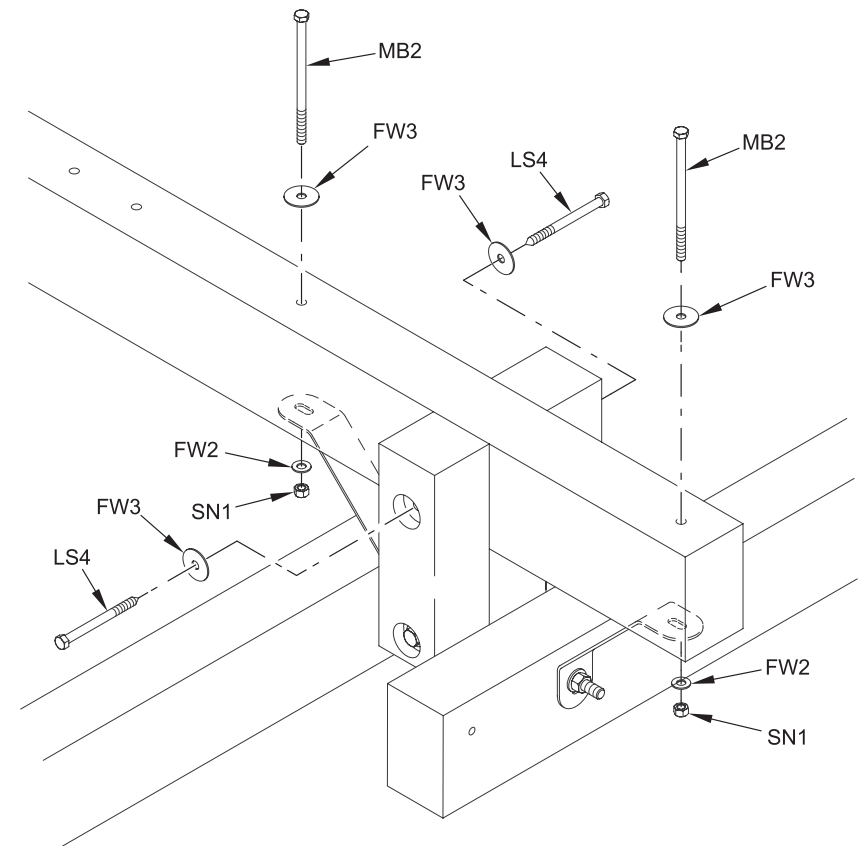

STEP 4: RAISE HEADBEAM & ATTACH TO PLAYSET

4

PARTS NEEDED:

(1) D (Cross Brace)

HARWARE NEEDED:

(2) CB1 (1/2" X 6 1/2" Carriage Bolt)

(2) FW5 (1/2" Flat Washer)

(2) LW1 (1/2" Lock Washer)

(2) SN3 (1/2" Hex Nut)

(2) FW3 (3/8" Fender Washer)

(2) FW6 (1/2" Large Washer)

(2) LS5 (3/8" X 5 1/2" Lag Screw)

ADDITIONAL HARDWARE DETERMINED BY WHICH SET YOU PURCHASE.

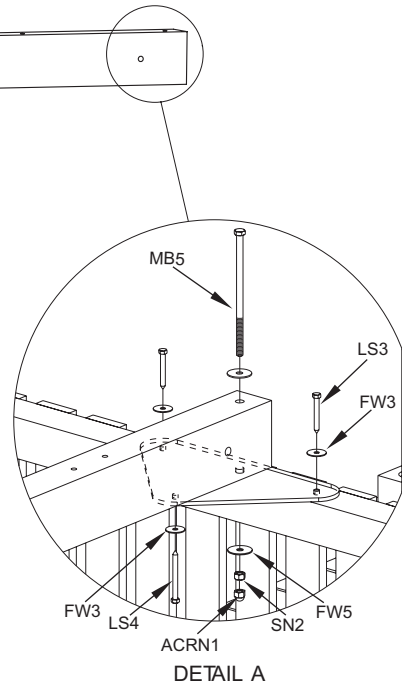
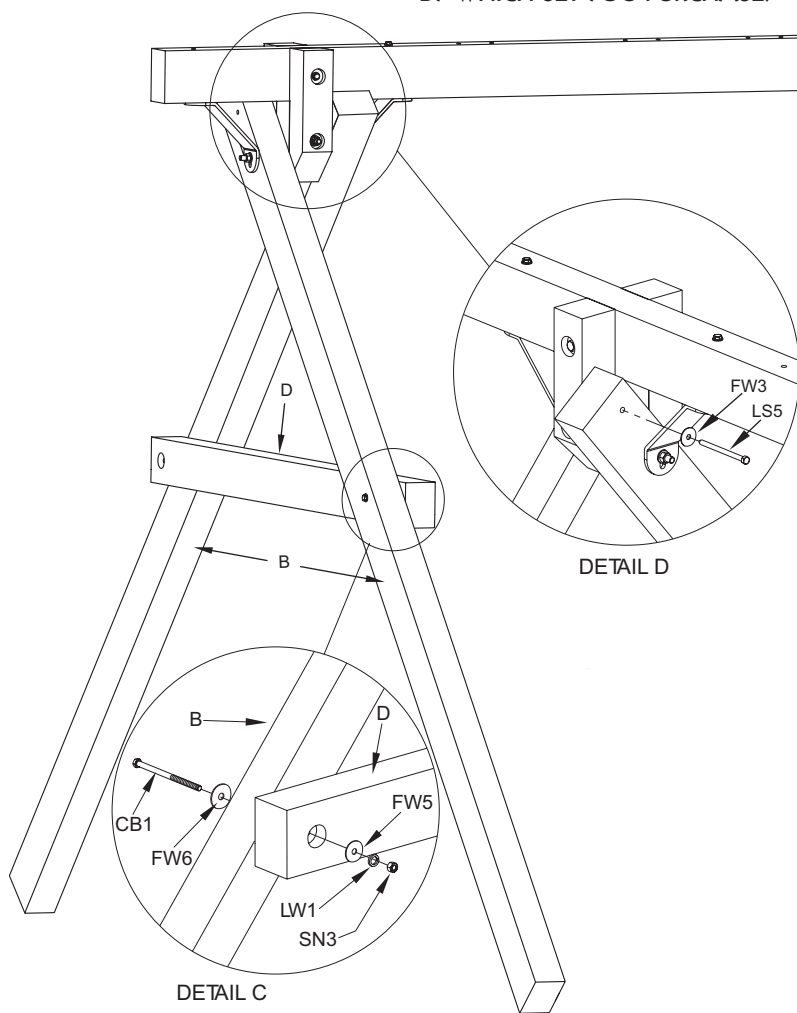

HARWARE NEEDED:

(1) PL (Steel Triangular Plate)

(1) MB5 (1/2" X 9" Machine Bolt)

(2) FW5 (1/2" Flat Washer)

(1) SN2 (1/2" Lock Nut)

(1) ACRN1 (1/2" Acorn Nut)

(2) LS3 (3/8" X 5 1/2" Lag Screw)

(1) LS4 (3/8" X 4" Lag Screw)

(3) FW3 (3/8" Fender Washer)

Before raising the headbeam, place the hardware needed to attach the headbeam up in the playset so it will be handy. If the attachment requires the Steel Triangular Plate (PL), go ahead and attach the plate to the safety rail.

With a helper, carefully lift the headbeam from both ends till it is level with the safety rail of playset while bringing the A-Frame legs together to support the headbeam. Place the headbeam on the safety rail being extremely careful it does not slip off and fall. With one person in the playset and the other steadying the A-Frame bolt the headbeam to the fort as shown. Using MB5, FW5, SN2 and ACRN1. (see Detail A)

Place part D into position between parts B as shown. Using a level determine and mark the location of the holes to be made in part B so that the hole in part D is centered on part B. Mark the location on one side and drill a 1/2" hole in part B. Attach part D Using CB1, FW6, FW5, LW1 and SN3. (See Detail C)

With one side of part D attached, check the location of the mark for the other hole and adjust if needed. Drill the hole and finish attaching part D. Once the AFrame And headbeams are attached and level, tighten all bolts and install the LS5 and FW3 at the top of part B. (See Detail D)

ChildLife® Playsets

ChildLife Limited Lifetime
& TwoYear Warranties

Subject to proper installation and normal residential use, Escalade Sports warrants, subject to the limitations stated below, to the original retail purchaser, all chain, seats, swing hangers, hardware, metal braces, ropes and accessories to be free from defects in material and workmanship for a period of two years from date of purchase. Cracks in non-functional plastic components are not considered defects in materials and workmanship if they do not affect the functionality of the playset. Merchandise covered under this limited two-year warranty will, at our option, be repaired or replaced, excluding **any freight or labor fees that may be required.**

In addition, for the lifetime of the playset, Escalade Sports warrants, to the original retail purchaser, all wooden components against structural failure due to corrosion, wood rot, or insect infestation. **Seasonal checks and surface cracks, knotholes and knots, natural characteristics of all wooden play equipment, not resulting in structural failure, are not covered under this warranty.**

Timber is a natural material which can absorb and release moisture. Although this product is designed to minimize this effect, in certain circumstances some movement or distortion is unavoidable. During dry hot weather timber may shrink and check - this is a normal process of weathering. After the first year of service it is advisable to apply a non-toxic stain / sealant safe for children's use.

Components covered under this limited lifetime warranty will be replaced free of charge excluding freight and labor fees.

Non-residential use of the playset is prohibited and voids the warranty as the playsets are designed for residential use only.

Escalade Sports reserves the right to examine photographs and/or physical evidence of merchandise claimed to be defective, and to recover said merchandise, prior to disposition of warranty claims. Merchandise returned to our factory for examination or recovery must be shipped freight prepaid, unless a Return Authorization Number is issued.

No warranty is offered on equipment subjected to abuse, negligence, improper installation, vandalism, acts of God, unauthorized alteration or attachment to equipment other than our own, or improper use, service or repair by customer or any third party. Escalade Sports assumes no responsibility for incidental or consequential damages which may arise from the purchase or use of our equipment. Please supervise your children's play activity and maintain your play equipment periodically.

THIS WARRANTY IS EXPRESSLY IN LIEU OF ALL OTHER WARRANTIES, EXPRESSED OR IMPLIED, INCLUDING WARRANTIES OF MERCHANTABILITY OR FITNESS FOR USE. CHIDLIFE PLAYSETS DOES NOT ASSUME, OR AUTHORIZE ANY PERSON TO ASSUME FOR US, ANY OTHER LIABILITY IN CONNECTION WITH THE SALE OF OUR PRODUCTS.

For warranty service, contact:

Childlife Playsets
Escalade Sports
P.O. Box 889
Evansville, IN 47706
1-800-GO-SWING

Or E-Mail us at: playgroundcs@escaladesports.com

Revised 2014