

Step 1. Through-fixing

1. Drill one 25mm hole (using spade bit) x 10mm deep and 2 off 9mm holes through door at required distance (backset) from door edge (refer Template).
2. Fit the stepped threaded post (1) provided to the threaded hole in underside of lever handle assembly (2).
3. Now holding the dummy fixing plate (3) fit threaded ferrule (4) using suitable screw (5) for door thickness.
4. Fit the dummy fixing plate to back face of door and fit the lever handle assembly to front face of door. Fit screw (6) 2 places to secure lever handle assembly to door.
5. Slide the rosette cover (7) over the lever (ensuring the notch in rosette cover is pointing to the floor) and fix into position (refer to diagram).
6. For square rosette cover tighten grub screw (8) using allen key (9), located on underneath side of rosette.

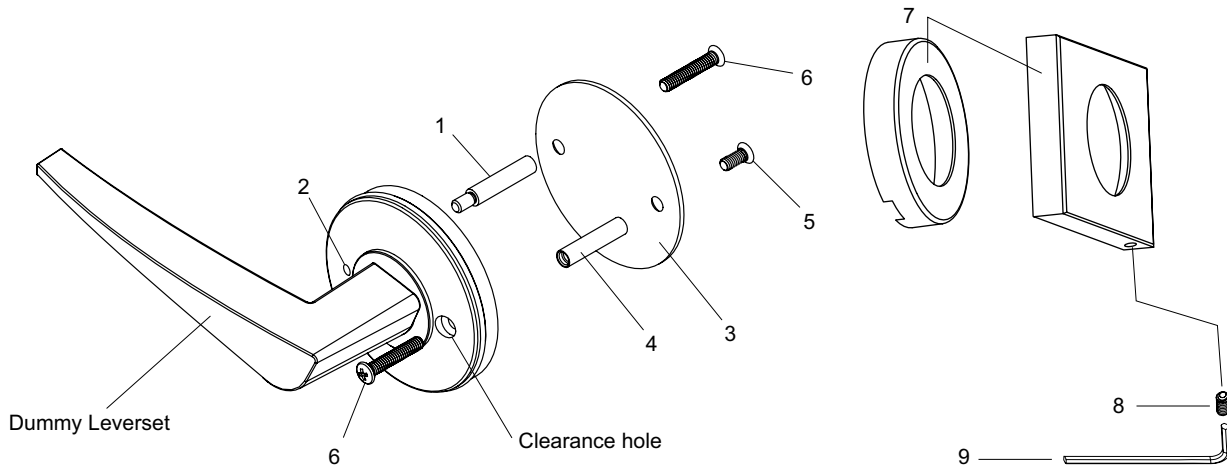

Note: Notch in round rosette cover or grub screw hole in square rosette cover should point to floor – refer diagram.

NOTE: Carefully follow these instructions when installing. Screws to be tightened to a recommended 2.5Nm torque.



FOLD HERE

FOLD HERE

Fit here on door edge

Fit here on door edge

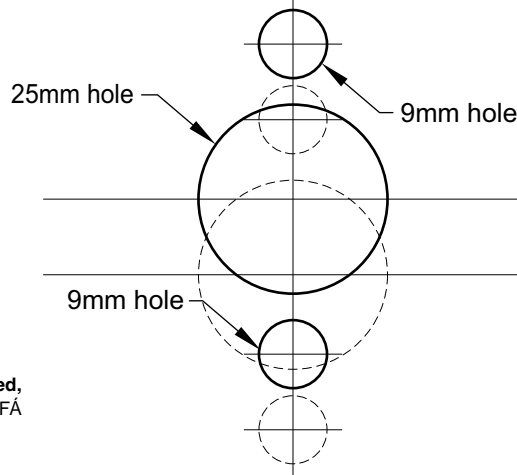

Installation template for dummy applications