

SMART APP ONLINE UPS SERIES

INSTALLATION AND OPERATION MANUAL

OL1KRTHDTAA / OL1K5RTHDTAA / OL2K2RTHDTAA / OL3KRTHDTAA

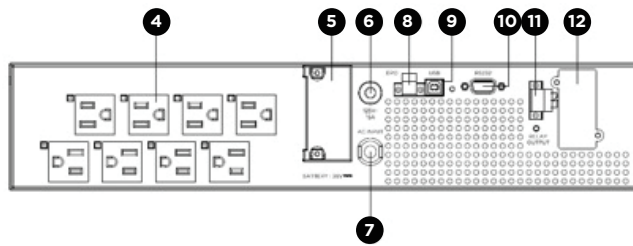
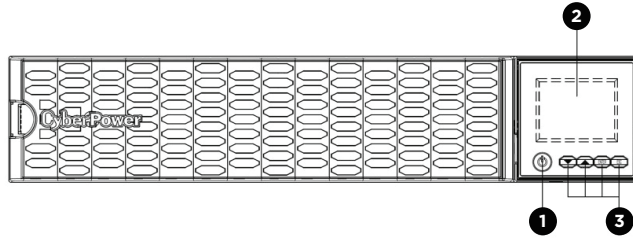

OL1KRTHDTAA / OL1K5RTHDTAA

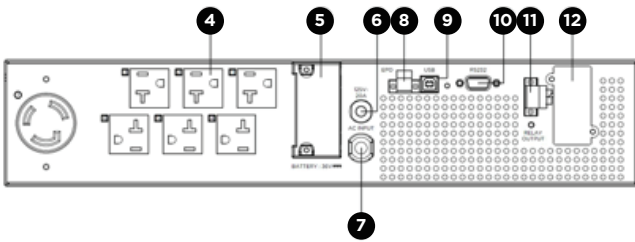

OL2K2RTHDTAA

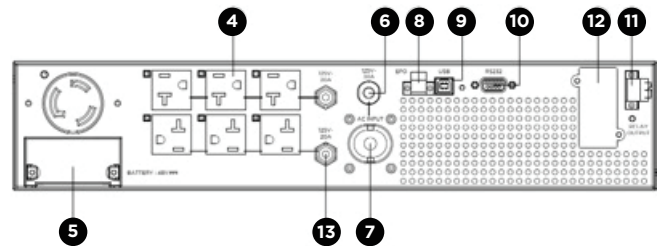

OL3KRTHDTAA

- | | |
|--|--|
| 1. Power Button / Power On Indicator | 8. EPO (Emergency Power Off) Connector |
| 2. UPS Status / Multifunction LCD Readout | 9. USB (HID Compliant) Port |
| 3. Function Buttons | 10. Serial Port |
| 4. Individual Banks (Outlets) for Battery Backup and Surge Protected | 11. Relay Output Connector |
| 5. Extended Runtime Battery Module Connector | 12. Expansion Slot |
| 6. Input Circuit Breaker | 13. Output Circuit Breaker |
| 7. AC Input power cord | |

TABLE OF CONTENTS





SAFETY INSTRUCTIONS	3
SPECIAL SYMBOLS	3
PERSONAL SAFETY	3
SAFETY INSTRUCTIONS	4
INTRODUCTION	5
UPS	5
EXTENDED BATTERY MODULES	5
PACKAGE CONTENTS	5
SYSTEM BLOCK DIAGRAM	6
HARDWARE INSTALLATION GUIDE	6
BASIC OPERATION	7
HARDWARE INSTALLATION - RACKMOUNT INSTALLATION FOR 4-POST RACK	8
HARDWARE INSTALLATION - RACKMOUNT INSTALLATION FOR 2-POST RACK	9
HARDWARE INSTALLATION - VERTICAL/TOWER INSTALLATION	10
UPS SYSTEM STARTUP	11
USING THE UPS SYSTEM	12
LCD SCREEN - UPS MODES OF OPERATION	13
FUNCTION TREE	15
TROUBLESHOOTING	27
MAINTENANCE	29
Storage	29
Battery Replacement	29
Safety Precautions	29
BATTERY REPLACEMENT	30
TECHNICAL SPECIFICATIONS	32
PRODUCT REGISTRATION	34
CONFORMANCE APPROVALS	34
LIMITED WARRANTY AND CONNECTED EQUIPMENT GUARANTEE	34

SAFETY INSTRUCTIONS

SAVE THESE INSTRUCTIONS

This manual contains important instructions that should be followed during installation and maintenance of the UPS and batteries. The Smart App Online 1KVA-3KVA UPS models that are covered in this manual are intended for installation in an environment within 32°F to 104°F (0°C to 40°C), free of conductive contaminants.

SPECIAL SYMBOLS

	Warning: High voltage - Risk of Electric Shock
	Caution - Important Instructions: Must always be followed.
	Do Not Discard: The UPS or UPS batteries in trash. The batteries contain lead acid. For more information, contact your local recycling or hazardous waste facility.
	Information, advice, help
	See applicable user manual

PERSONAL SAFETY

⚠ **CAUTION!** To reduce the risk of fire, the unit connects only to a circuit provided with 15 amperes (OL1KRTHDTAA, OL1K5RTHDTAA); 20 amperes (OL2K2RTHDTAA); 30 amperes (OL3KRTHDTAA) maximum branch circuit overcurrent protection in accordance with the National Electric Code, ANSI/NFPA 70.

⚠ **CAUTION!** The AC electrical service where the UPS is connected should be close to the unit and easily accessible.

⚠ **CAUTION!** Please use only UL-marked mains cable, (e.g. the mains cable of your equipment), to connect the UPS to the AC outlet.

⚠ **CAUTION!** Please use only UL-marked power cables to connect any equipment to the UPS.

⚠ **CAUTION!** When installing the equipment, ensure that the sum of the leakage current of the UPS and the connected equipment does not exceed 3.5mA.

⚠ **CAUTION!** Do not unplug the unit from AC power during operation, as this will disconnect the protective ground insulation.

⚠ **CAUTION!** Do not use an improper size power cord as it may cause damage to your equipment and cause fire hazards.

⚠ **CAUTION!** Make sure everything is turned off and disconnected completely before conducting any maintenance, repairs or shipment.

⚠ **CAUTION!** DO NOT INSTALL THE UPS WHERE IT WOULD BE EXPOSED TO DIRECT SUNLIGHT OR NEAR A STRONG HEAT SOURCE!

⚠ **CAUTION!** DO NOT BLOCK OFF VENTILATION OPENINGS AROUND THE HOUSING!

⚠ **CAUTION!** DO NOT CONNECT DOMESTIC APPLIANCES SUCH AS HAIR DRYERS TO UPS OUTPUT SOCKETS!

⚠ **CAUTION!** SERVICING OF BATTERIES SHOULD BE PERFORMED OR SUPERVISED BY PERSONNEL KNOWLEDGEABLE OF BATTERIES AND THE REQUIRED PRECAUTIONS. KEEP UNAUTHORIZED PERSONNEL AWAY FROM BATTERIES!

⚠ **CAUTION!** FOR PERMANENTLY CONNECTED EQUIPMENT, A READILY ACCESSIBLE DISCONNECT DEVICE SHALL BE INCORPORATED IN THE BUILDING INSTALLATION WIRING.

SAFETY INSTRUCTIONS



WARNING!

WARNING! RISK OF ELECTRIC SHOCK

RISK OF ELECTRIC SHOCK

A battery can present a risk of electric shock and high short circuit current. The following precaution should be observed when working on batteries:

- a) Remove watches, rings or other metal objects.
- b) Use tools with insulated handles.
- c) Wear rubber gloves and boots.
- d) Do not lay tools or metal parts on top of batteries.
- e) Disconnect charging source prior to connecting or disconnecting battery terminals.
- f) Remove battery grounds during installation and maintenance to reduce likelihood of shock. Remove the connection from ground if any part of the battery is determined to be grounded.

The UPS must be connected to a grounded AC power outlet with fuse or circuit breaker protection. DO NOT plug the UPS into an outlet that is not grounded. If you need to power-drain this equipment, turn off and unplug the unit.

No User Serviceable Parts: Risk of electric shock, do not remove cover. No user serviceable parts inside. Refer servicing to qualified service personnel.

To prevent the risk of fire or electric shock, install in a temperature and humidity controlled indoor area, free of conductive contaminants. (Please see specifications for acceptable temperature and humidity range).

To avoid electric shock, turn off and unplug the unit before installing the input/output power cord with a ground wire. Connect the ground wire prior to connecting the line wires!

Connect the Protection Earth (PE) safety conductor before any other cables are connected.

Fuses: To reduce the risk of fire, replace only with the same type and rating of fuse.

⚠ **WARNING!** The battery can power hazardous components inside the unit, even when the AC input power is disconnected. The UPS should be placed near the connected equipment and easily accessible.

Non-Isolated Battery Supply: Risk of electric shock, battery circuit is not isolated from AC power source; hazardous voltage may exist between battery terminals and ground. Test before touching.

⚠ **WARNING! DO NOT USE FOR MEDICAL OR LIFE SUPPORT EQUIPMENT!** Under no circumstances should this unit be used for medical applications involving life support equipment and/or patient care.

⚠ **WARNING! DO NOT USE WITH OR NEAR AQUARIUMS!** To reduce the risk of fire, do not use with or near aquariums. Condensation from the aquarium can come in contact with metal electrical contacts and cause equipment to short out.

The unit has a dangerous amount of voltage. When the UPS indicators are on, the units may continue to supply power thus the unit's outlets may have a dangerous amount of voltage even when it is not plugged in to the wall outlet.

BATTERY PRECAUTIONS

⚠ **CAUTION!** Do not dispose of batteries in fire as the battery may explode.

⚠ **CAUTION!** Do not open or mutilate the battery, released material is harmful to the skin and eyes. It may be toxic.

⚠ **CAUTION!** RISK OF EXPLOSION IF BATTERY IS REPLACED BY AN INCORRECT TYPE. DISPOSE OF USED BATTERIES ACCORDING TO THE INSTRUCTIONS.

⚠ **CAUTION!** When replacing batteries, replace with the same number of the following battery:
CyberPower RB1290X3E for OL1KRTHDTAA, RB1290X3E for OL1K5RTHDTAA, RB1290X4M for OL2K2RTHDTAA and RB1290X4M for OL3KRTHDTAA.

⚠ **CAUTION!** Risk of Energy Hazard, 36V (OL1KRTHDTAA / OL1K5RTHDTAA) and 48V (OL2K2RTHDTAA / OL3KRTHDTAA), maximum 9.4 Ampere-hour battery. Before replacing batteries, remove conductive jewelry such as chains, wrist watches, and rings. High energy through conductive materials could cause severe burns.

INTRODUCTION

UPS

CyberPower Smart App Online rack/tower UPS systems, with double-conversion topology, provide sine wave output to mission-critical applications and equipment requiring seamless power correction. These units offer generator compatibility and deliver clean AC power with zero transfer time.

They offer Smart Battery Management (SBM), which helps extend overall battery life, and Fast Charge Technology, which helps keep charge times to less than four hours, regardless of the number of Extended Battery Modules (EBMs). Features include energy-saving GreenPower UPS™ ECO Mode technology, and PowerPanel Business software for monitoring and managing the UPS. Smart App Online 1KVA-3KVA UPS systems come with a three-year warranty and a \$400,000 Connected Equipment Guarantee.

EXTENDED BATTERY MODULES

Extended Battery Modules (EBMs) from CyberPower (BP36VL2U01TAA / BP48VL2U01TAA) increase battery runtimes during power outages. Each rack/tower convertible EBM uses 2U of rack space, depending upon the model, and can be installed in a tower form factor to match the UPS installation. The DC plug-and-play power connectors allow to daisy-chain additional EBMs to a UPS system. EBMs compatible with Smart App Online UPS systems also have a built-in battery charger, providing Fast Charge Technology to quickly restore the backup power supply. Every CyberPower EBM has a three-year warranty.

PACKAGE CONTENTS

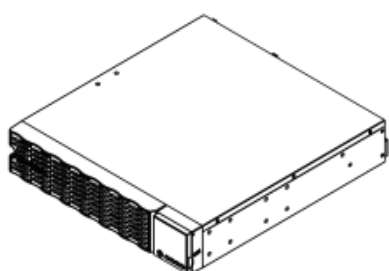

A

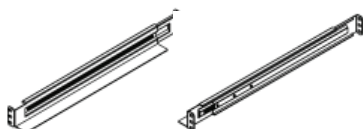

B



C



D

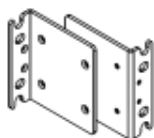

E



F



G



H



I



J



K



L



M

- | | |
|--|---|
| A. UPS x 1 | I. Black M4X8L flat head screws x 8 |
| B. Left and right rackmount rails x 1 each | J. Black M3X6L flat head screws x 4 |
| C. Serial Interface Cable (RS-232) x 1 | K. Rubber pads x 12 |
| D. USB communication cable x 1 | L. Cage nuts x 10 |
| E. Rackmount ears x 2 | M. Screw hole dust covers x 18 |
| F. Rackmount handles x 2 | N. Installation and Operation Manual,
Registration warranty card,
PowerPanel® Management Software download card |
| G. Black M5X8L pan head screws x 10 | |
| H. Black M4X7L pan head screws x 4 | |

SYSTEM BLOCK DIAGRAM

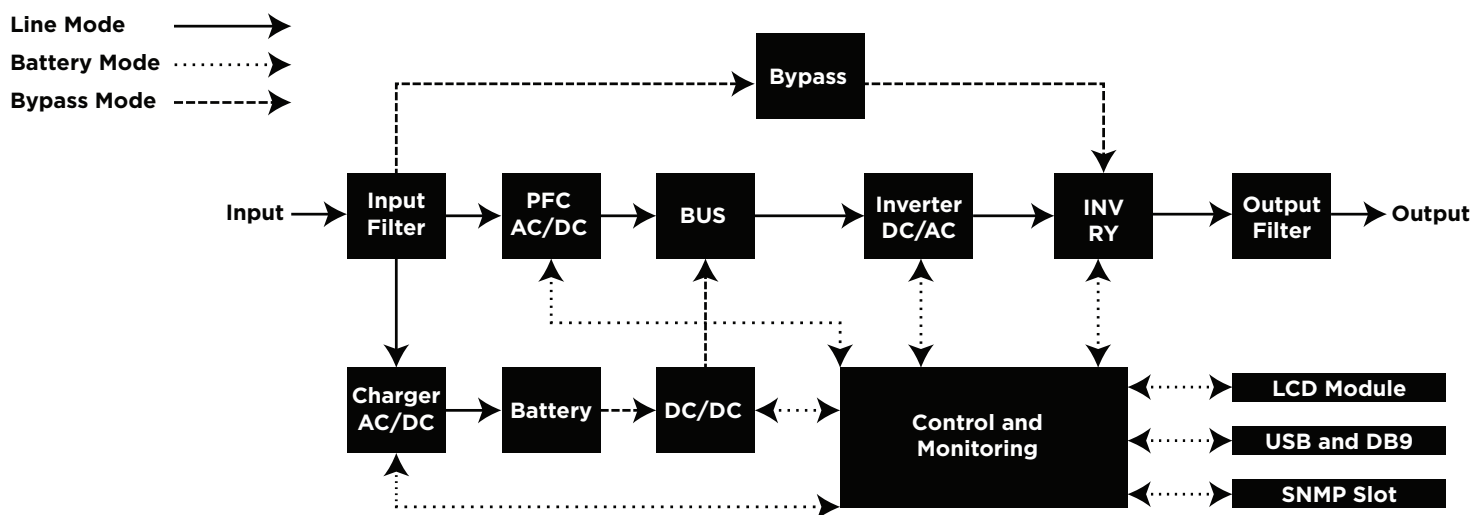

HARDWARE INSTALLATION GUIDE

1. Battery charge loss may occur during shipping and storage. Before using the UPS, it is strongly recommended to charge batteries for four hours to ensure the batteries' maximum charge capacity. To recharge the batteries, simply connect the UPS to its designated AC electrical service.
2. When using PowerPanel Business software, connect either the serial or the USB cable between the computer and the corresponding port on the UPS. Note: If the USB port is used, the serial port will be disabled. They cannot be used simultaneously. After connecting to either the USB port or the serial port on the UPS, a computer with PowerPanel Business software installed can control the operating schedule, battery test, outlets, as well as obtain UPS status information. However, other computers with PowerPanel Business Client software can only obtain UPS status information via LAN connection.
3. Connect your computer, monitor, and any externally-powered data storage device (Hard drive, Tape drive, etc.) into the outlets only when the UPS is off and unplugged. DO NOT plug a laser printer, copier, space heater, vacuum, paper shredder or other large electrical device into the UPS. The power demands of these devices will overload and possibly damage the unit.
4. Press the ON/OFF switch to turn the UPS on. The Power-On indicator LED will turn on when activated. If an overload is detected, an audible alarm will sound and the UPS will continuously emit two beeps per second. For resetting the unit, unplug some equipment from the outlets. Make sure your equipment carries a load current within the unit's safe range, (refer to the technical specifications).
5. This UPS is equipped with an auto-charge feature. When the UPS is connected to AC electrical service the battery will automatically charge, even when the unit is switched off.
6. To maintain an optimal battery charge, leave the UPS connected to AC electrical service at all times.
7. Before storing the UPS for an extended period of time, turn the unit OFF. Then cover it and store it with the batteries fully charged. Recharge the batteries every three months to ensure good battery capacity and long battery life. Maintaining a good battery charge will help prevent possible damage to the unit from battery leakage.
8. The UPS has one USB port (default) and one serial port that allows connection and communication between the UPS and any attached computer running PowerPanel Business software. The UPS can control the computer's shutdown during a power outage through the connection while the computer can monitor the UPS and alter various programmable parameters. Note: Only one communication port can be used at a time. The port not in use will automatically become disabled or the serial port will be disabled if both ports are attached.
9. EPO (Emergency Power Off) Port: EPO ports allow administrators the capability to connect the UPS unit to customer-supplied EPO switches. These installations give operators a single access point to immediately power-off all equipment connected to the UPS during an emergency. EPO function is provided in UPS. EPO remote switch which is Push-Back button is installed computer room outside by a phone line, and not connected any other equipment.
10. To avoid electric shock, turn the unit OFF and disconnect the unit from utility power before hardwiring the UPS (in/out power cord). The in/out power cord MUST be grounded.
11. Please note the internal UPS temperature will increase when fans are not in operation or ventilation is obstructed. When the high temperature sensor activates protection, the UPS generates an alarm and shuts down to avoid unexpected equipment damage. When the over temperature occurs, please check the Troubleshooting section. If the condition persists, please contact CyberPower for technical support.
12. The UPS may be used with a maximum of ten extended battery modules.

BASIC OPERATION

1. Power Button / Power on Indicator

Master ON/OFF switch for the UPS. Indicates that the UPS is on and supplying power.

2. UPS Status / Multifunction LCD Readout

Shows UPS status, information, settings and events.

3. Function Buttons

Scroll DOWN scroll UP, ENTER, and ESCAPE.

4. Individual Banks (Outlets) for Battery Backup & Surge Protected

Provides battery backup and surge protection. They ensure power is provided to connected equipment during the utility power failure.

Programmable Individual Banks (Outlets)

Allows the creation of load priorities to ensure that battery power reserves are transferred to specified individual banks (outlets) during a power outage.

The unit can be programmed to provide additional runtime for equipment connected to the individual banks (outlets) which support to main equipment, while stopping the power supply to non-major equipment connected to other individual banks (outlets) after a specified set time or capacity.

Individual Banks (Outlets)

These can be programmed, scheduled or controlled remotely to supply power to different devices.

5. Extended Runtime Battery Module Connector

Connection for additional CyberPower External Battery modules.

6. Input Circuit Breaker

Provides input overload and fault protection.

7. AC Input power cord

Connect to utility power

8. EPO (Emergency Power Off) Connector

Enables an emergency UPS power-off from a remote location.

9. USB (HID Compliant) port

USB port provides communication between the UPS and a computer. The UPS can trigger a computer with PowerPanel Business software installed to shut down during a power outage through the connection while the computer can monitor the UPS and change its various programmable settings.

10. Serial port

Serial port provides RS-232 communication between the UPS and a computer. The UPS can trigger a computer with PowerPanel Business software installed to shut down during a power outage through the connection while the computer can monitor the UPS and change its various programmable settings. Note: USB communication has priority over serial port.

11. Relay Output Connector

Convert UPS signals into real potential-free dry contacts for industrial controls.

12. Expansion Slot

Slot to install optional remote management card.

13. Output Circuit Breaker

Provides output current overload and fault protection.

HARDWARE INSTALLATION - RACKMOUNT INSTALLATION FOR 4-POST RACK

CyberPower UPS systems can be installed in a rackmount or vertical/tower orientation. This versatility is especially important to growing organizations with changing needs that value having the option to position a UPS on the floor or in a rackmount system. Please follow the instructions below for the respective mounting methods.



CAUTION!

CAUTION! To prevent the risk of fire or electric shock, only use the supplied hardware to attach the mounting brackets.

Step 1: Screw the handles and install rackmount ear

Screw the handles on the rack-mount ears using four black M3X6L flat head screws as shown below. Attach two rackmount ears to the UPS using eight black M4X8L flat head screws.

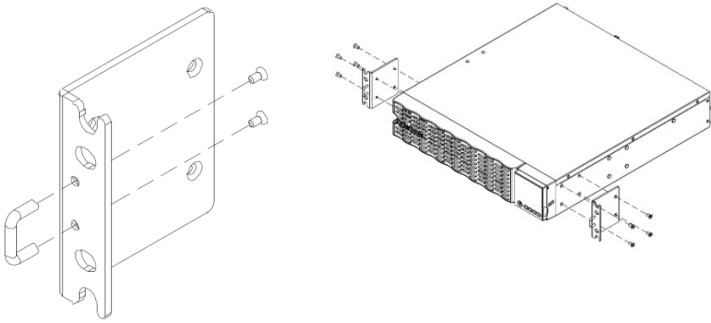

Step 2: Rackmount rail Installation

Select the proper holes in the rack for positioning the UPS in the rack. The UPS takes up 2 rack units: rack hole positions 1 through 6.

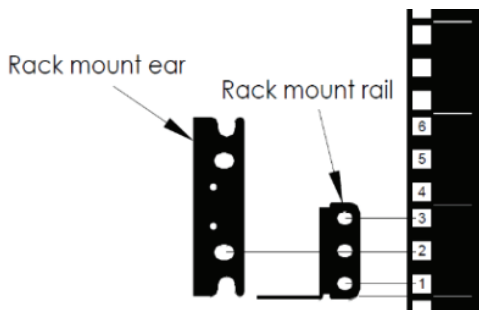

Step 3: Select the proper holes to insert the cage nuts

Select the proper holes in the rack for positioning the unit in the rack. Insert the cage nuts (Not needed for threaded rack)

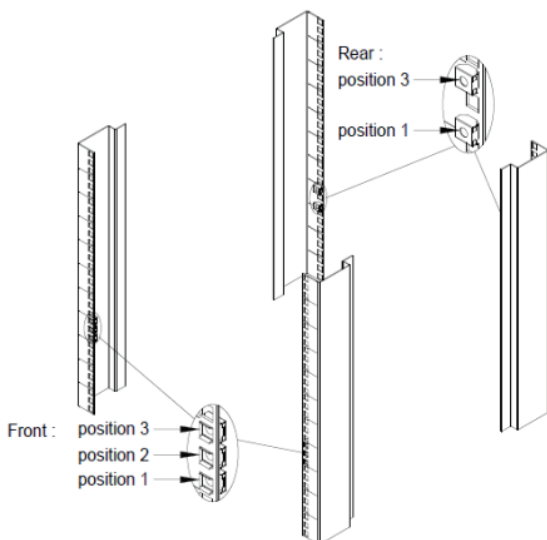

Step 4: Adjust rackmount rails to fit your rack

The mounting depth of the included rackmount rails can adjust from 18.1 in to 29 in (46 cm to 73.5 cm). Adjust the rail depth to match your rack depth. Attach each rackmount rail to your rack with two black M5X8L pan head screws at the front of the rack (square holes 1 and 3 as shown below). Secure each rail to the rear of the rack with two black M5X8L pan head screws.

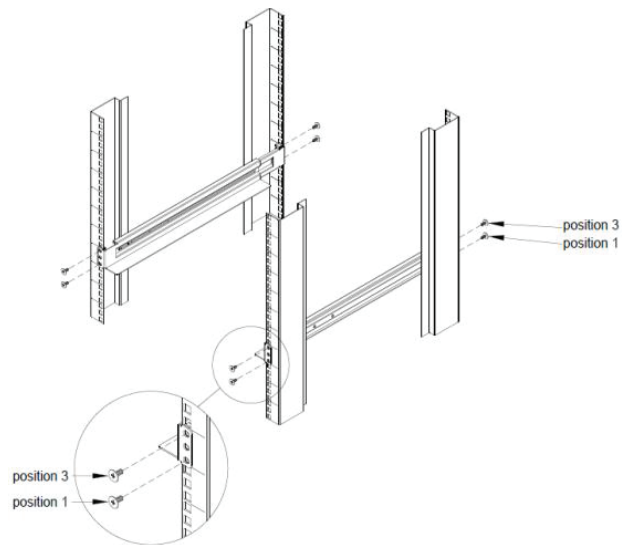



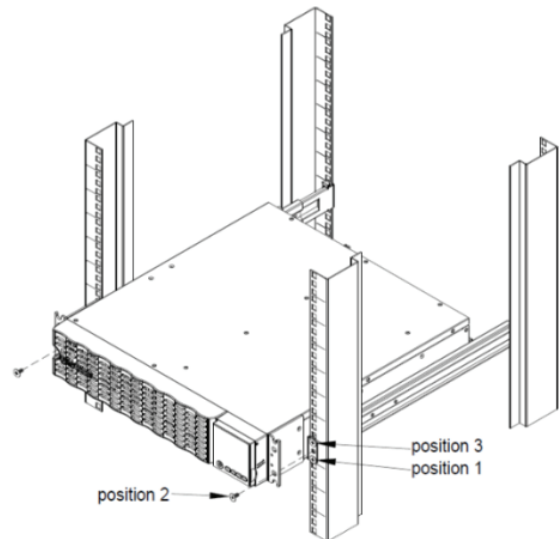

Step 5: Place and secure the UPS on the rails

Slide the hanging brackets on the UPS onto the rails mounted in the rack with the front of the unit facing toward you. Secure the UPS to your rack with two black M5X8L pan head screws at the front of the rack (square holes 2 and 5 as shown above).



HARDWARE INSTALLATION - RACKMOUNT INSTALLATION FOR 2-POST RACK

 CAUTION!	Due to the weight of this unit, it is strongly recommended to install it at the bottom of the rack.
 CAUTION!	Prior to installing the unit, remove internal batteries to reduce the weight of the unit. Refer to the battery replacement section in this user manual for instructions.
 CAUTION!	It is strongly recommend having two to three people assist during the installation process.
 CAUTION!	It is strongly recommended that the 2-post rack be bolted to the floor prior to the installation of the UPS.

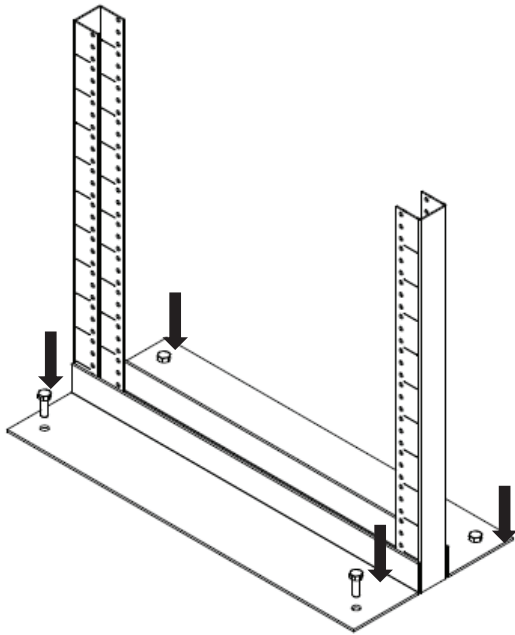

Step 1: Remove side dust covers and install rackmount ears

Remove eight dust covers from screw holes as shown below. Attach the included rackmount ears to the center holes on the sides of the UPS using eight black M4X8L flat head screws as shown below.

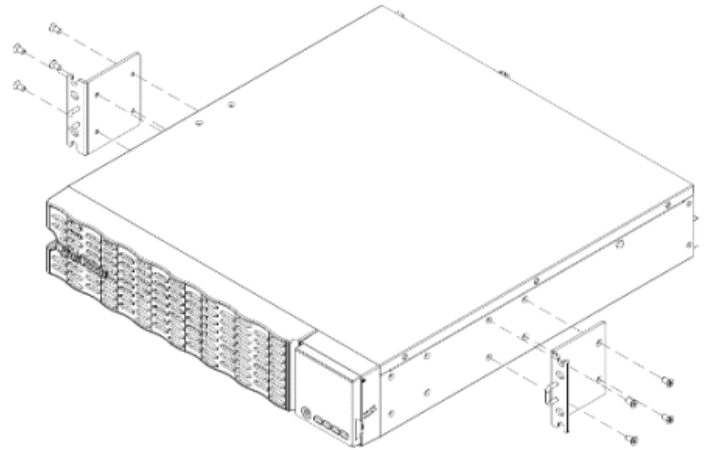
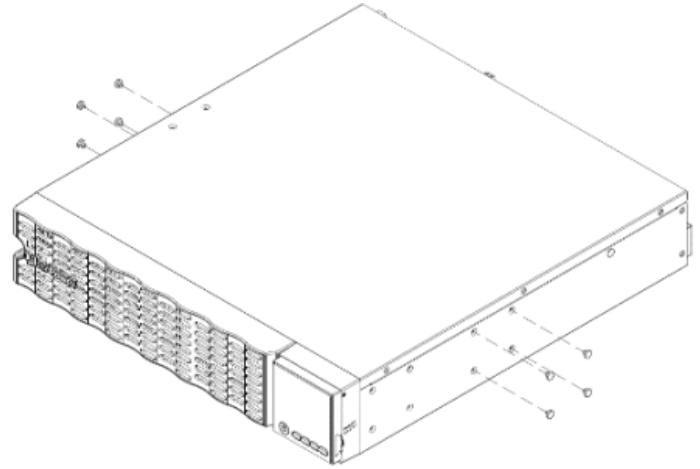

Step 2: Secure the UPS to the rack

Secure the UPS to your rack with four black M5X8L screws at the front of the rack (square holes 2 and 5 as shown below).

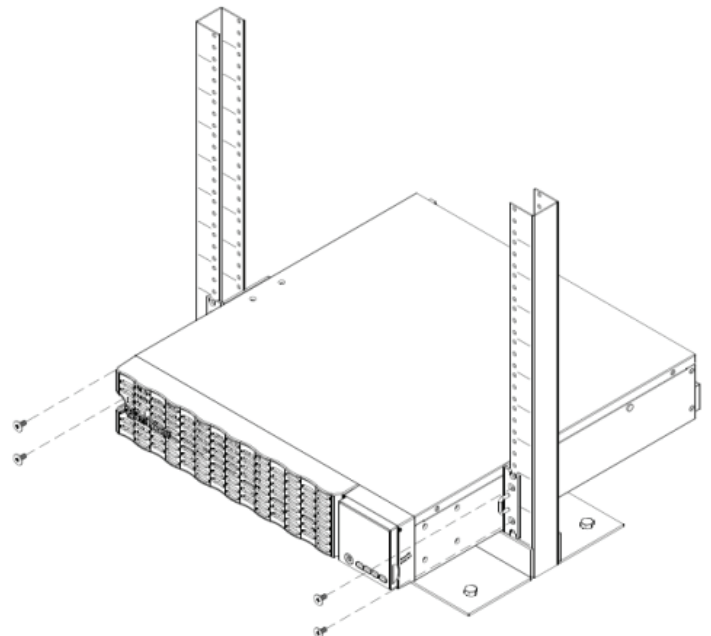

HARDWARE INSTALLATION - VERTICAL/TOWER INSTALLATION

Step 1: Adhere rubber pads

Adhere twelve circular rubber pads to the stands and to the left-hand side of the UPS as shown below. This will become the bottom of the UPS. Insert the dust covers into the open screw holes on bottom.

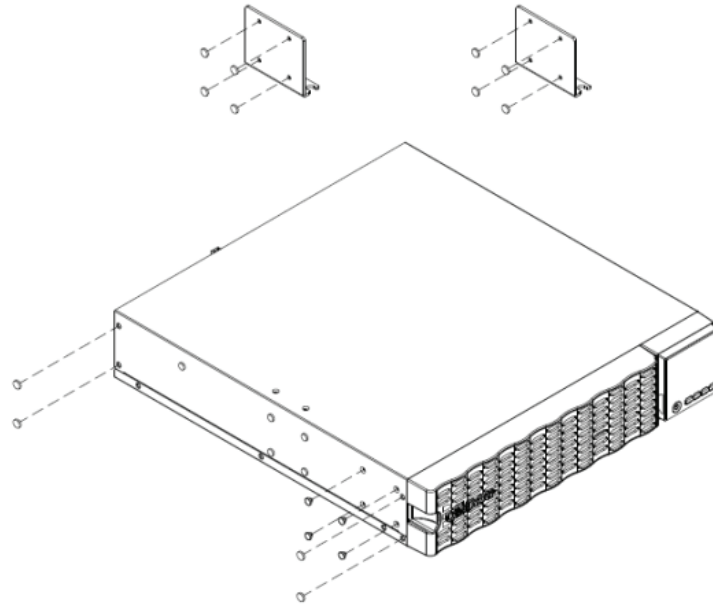

Step 2: Attach the base stands and attach the dust covers

Stand the UPS system on its side and tighten the screws on the tower stands onto the bottom of the UPS as shown below. Insert the dust covers into the open screw holes on top.

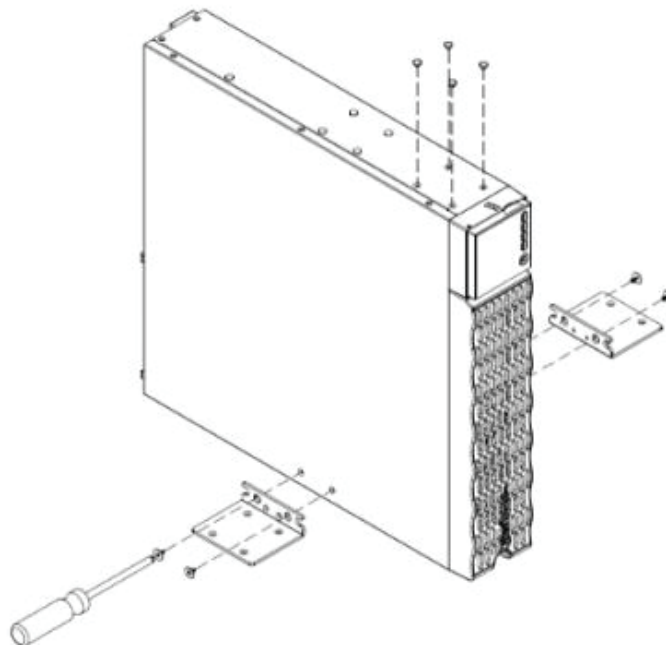

After completing the hardware installation of the UPS, you are now ready to connect the UPS and connect your equipment.

UPS SYSTEM STARTUP

To start the UPS:

1. Verify that the UPS input cable or terminal blocks are connected to AC source.
2. The UPS LCD shows "Standby Mode" and fans turn on.



3. Press the ON/OFF button on the UPS front panel for at least 3 seconds to turn On the UPS.
4. UPS will perform a brief self-test lasting about 15 seconds. The LCD will show result in the sequence below.

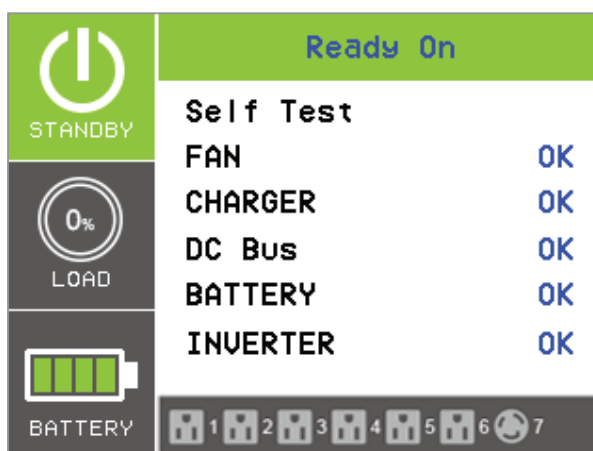

5. The UPS is operating in Battery Mode first then transfers to Line Mode if Input power is qualification and powering the output.

USING THE UPS SYSTEM

LCD Panel



Item	Button	Function Description
1	ON/OFF	Press this button for at least 3 seconds to turn on or turn off UPS.
2	▼	Press this button to scroll down in the LCD menu.
3	▲	Press this button to scroll up in the LCD menu.
4	Enter	Press this button to select an option.
5	ESC	Press this button to cancel or return to previous LCD menu.

USING THE UPS SYSTEM

LCD Display Introduction

UPS Summary: There are three display Zones: Icon Zone, Content Zone and Bank (Outlet) Zone.

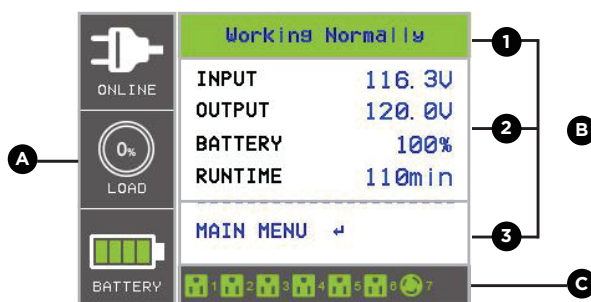

A. ICON ZONE: In the Left area, there are three icons for displaying the UPS working status / Load % / Battery Capacity and, depending on UPS status changing, the icons will display Warning and Fault with a yellow or red color.

B. CONTENT ZONE: In the middle and right screens:

1. The top of the content area is for displaying UPS working information: Working Normally (Line Mode) / V+Hz out of range (Battery Mode) / etc.
2. The central area is the UPS Status which depends on different UPS status to provide different information including: Input / Output / Battery / Load parameters.
3. The bottom area of the content zone is the function select index including: Main Menu and quick link selection which depends on different UPS status to provide relevant functional link.

C. BANK (outlet) ZONE: The bottom area is for displaying UPS individual bank Information: Bank On/Bank Off.

- The number beside the outlet icon is the outlet number.
- Depending on different UPS models, one bank may have two outlet numbers.
- From left to right are the bank numbers 1, 2, 3, etc.
- Green outlet means the Bank is On and has output voltage.
- Gray outlet means the Bank is Off and has no output voltage.

Push Enter Button to Main Menu when UPS displays the summary page.

LCD SCREEN - UPS MODES OF OPERATION

Icon	Working Information	Modes Description
	Standby	A utility power has been connected but UPS is Off.
	Working Normally	UPS is operating in Line Mode. The UPS is operating and protecting the equipment normally
	V+Hz out of range	UPS is operating in Battery Mode. A utility power failure (V+Hz/V/Hz out of range) has occurred. The UPS is using battery power to work and protect the equipment.
	V out of range	
	Hz out of range	
	Bypass Mode Warning or Fault Information	UPS is operating in Bypass Mode. A Warning or fault has been detected and the UPS transfers output to utility power.
	Manual Bypass	UPS is operating in Manual Bypass. The UPS has been manually transferred to bypass for maintenance purposes.
	ECO Mode	UPS is operating in ECO (Economy) Mode. If Bypass quality is within the ECO mode setting specifications, the UPS will operate in Bypass until input power is disqualified per set specifications. At that time the UPS will automatically switch to Line Mode.

USING THE UPS SYSTEM

LCD SCREEN - UPS MODES OF OPERATION CONT.

LCD will use a red or yellow color to indicate the Fault or warning status and also connect the color frame with icon which has the same color and located on the left zone of the screen.

The UPS status in the UPS Summary page will provide the related information by different working function.

The Function Select Menu in the UPS Summary page will provide the quick link to related function.

Battery Mode

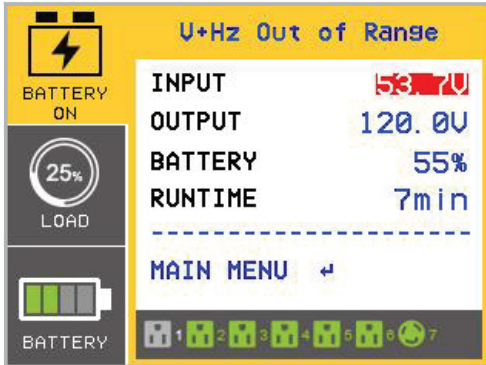

Output Overload

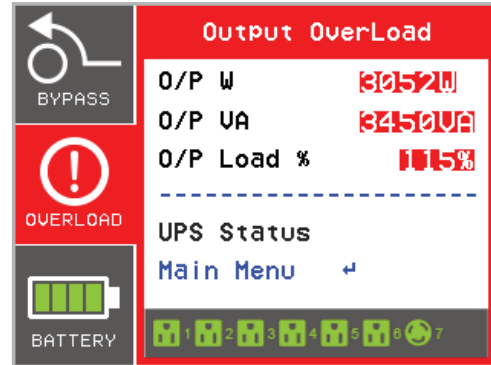





Press the **UP** and **DOWN** buttons to select the quick link function. Push **Enter** Button to select function page.

LCD SCREEN - Individual Bank (Outlet) Information

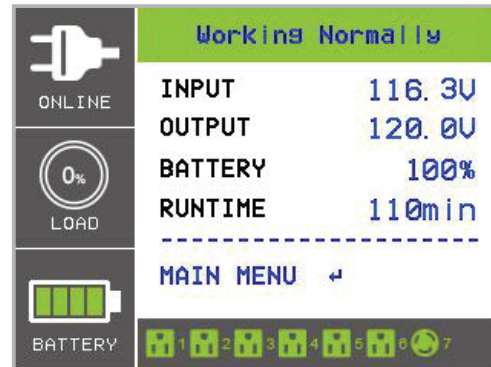
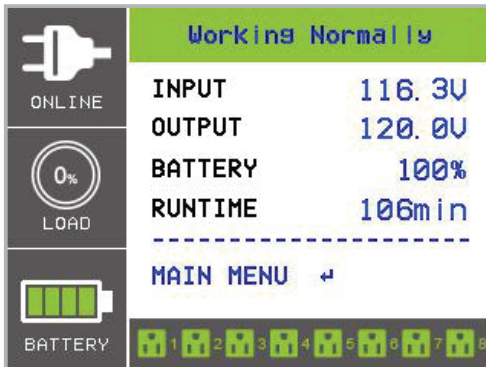
OL1KRTHTDAA / OL1K5RTHDTAA: 8 Banks (8 Outlets)

OL2K2RTHDTAA / OL3KRTHTDAA: 7 Banks (7 Outlets)



Outlet Icon	Description
 	Green: Display the Individual Bank (Outlet) Information: Bank (Outlet) On.
 	Gray: Display the Individual Bank (Outlet) Information: Bank (Outlet) Off.

USING THE UPS SYSTEM

Function Tree

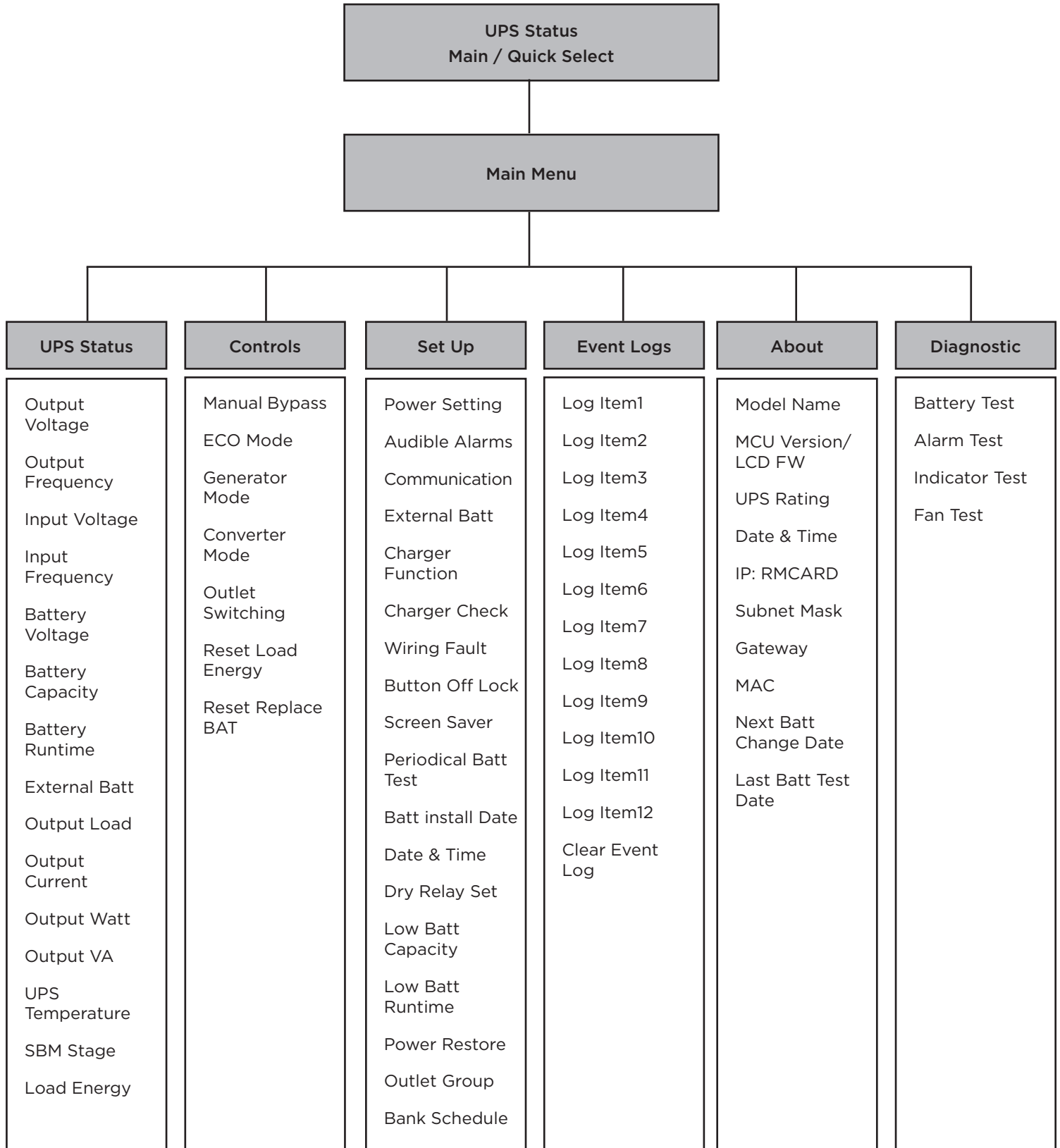





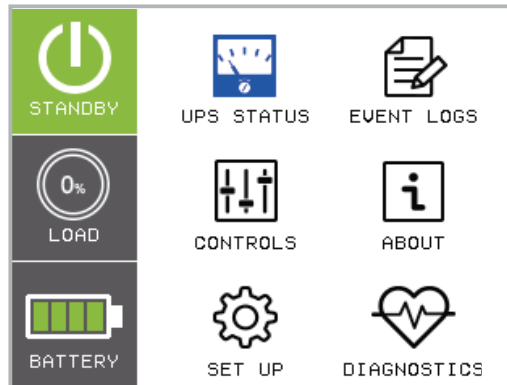

USING THE UPS SYSTEM

Main Menu: Function Select

The Main Menu has six icons of different functions listed in the table below.



Icon	Function Select Menu	Description
	UPS Status	Displays the UPS status
	Controls	Displays the UPS Control items that can be set by the user.
	Set Up	Displays the UPS Set Up items that can be configured by the user.
	Event Logs	Displays the 12 most recent events, by event count, time (Year/Month/Day Hour: Minute), and event description.
	About	Displays the UPS information.
	Diagnostic	Displays the UPS Diagnostics items that can be activated by the user.

USING THE UPS SYSTEM

1. UPS STATUS

There are 15 types of UPS status Readout available for display.

1. Select **UPS Status** Icons
2. Press the **ENTER** button to enter the **UPS Status**.
3. Press the **UP** and **DOWN** buttons to scroll through the UPS Status items shown in the table below.
4. Press the **ESC** button to return to the Main Menu.

There is a Navigation bar on the right area of content zone; it will indicate the current page in Navigation Bar.

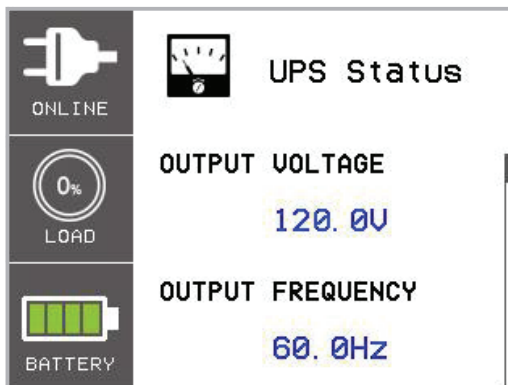

UPS STATUS ITEMS	DATA DISPLAYED	DESCRIPTION
OUTPUT VOLTAGE	= XXX.XV	Displays the Output Voltage
OUTPUT FREQUENCY	= XX.XHz	Displays the Output Frequency
INPUT VOLTAGE	= XXX.XV	Displays the Input Voltage
INPUT FREQUENCY	= XX.XHz	Displays the Input Frequency
BATTERY VOLTAGE	= XX.XV	Displays the Battery Voltage
BATTERY CAPACITY	= XXX%	Displays the Estimated Percentage of Battery Capacity
BATTERY RUNTIME	= XXXM	Displays the Estimated Battery Runtime in Minutes
EXTERNAL BATT	= X	Displays the Number of Extended Battery Modules Configured
OUTPUT LOAD	= XXX%	Displays the Output Load as a Percentage of Maximum Load
OUTPUT CURRENT	= XX.XA	Displays the Output Current
OUTPUT WATT	= XXXXW	Displays the Output Wattage
OUTPUT VA	= XXXXVA	Displays the Output VA
UPS TEMPERATURE	= XX°C / XXX°F	Displays the Approximate Internal UPS Temperature in both °C (Celsius) and °F (Fahrenheit)
SBM STAGE	= XXXXX XH(M)	Displays the stage of Smart Battery Management with Operation Time.
LOAD ENERGY	XXXX.XKWh	Display UPS Load Energy Consumption

USING THE UPS SYSTEM

2. CONTROLS

There are seven UPS items that can be controlled by the user.

1. Press the **UP** and **DOWN** buttons to select the **CONTROLS** icon.
2. Press the **ENTER** button to enter the **CONTROLS** function.
3. Press the **UP** and **DOWN** buttons to scroll to the **CONTROLS** option.
4. Press the **ENTER** button to select the **CONTROLS** submenu items shown in the table below.
5. Press the **ENTER** button to select the setting you want to set up.
6. The present **SET UP** parameter will be displayed by a blue color with a select mark in the front of setting parameters.
7. Press the **UP** and **DOWN** buttons to scroll through the different control functions.
8. Press the **ENTER** button to select the parameter you want to set.
9. You may be prompted **Activate?** to activate the selection. If so, press the **ENTER** button to activate the control function. Some options are started automatically. (See the following table and screen for additional details.)
10. Press the **ESC** button to cancel or return to the previous **SET UP** menu.

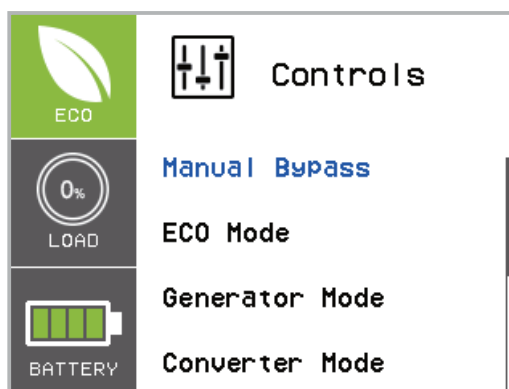

CONTROL ITEMS	AVAILABLE SETTINGS	DEFAULT SETTING
Manual Bypass	[Disable] [Enable]	Disable
	When performing UPS maintenance, the user can manually transfer the connected load to Bypass without interrupting the output to the connected equipment.	
ECO Mode This function cannot be set when Manual Bypass, Generator Mode or Converter Mode is enabled.	[Disable] [Enable]	Disable
	[Voltage = +/-15%] [Voltage = +/-10%] (for [Enable])	V Range = +/-10%
	When ECO mode is enabled the UPS will check the following specifications of Bypass quality (1) Bypass voltage is inside the [V Range= +/-10%] (default setting) or [V Range= +/-15%]. (2) Bypass frequency is inside the +/-3Hz range of output nominal frequency.	

USING THE UPS SYSTEM

CONTROL ITEMS	AVAILABLE SETTINGS	DEFAULT SETTING
Generator Mode UPS has no bypass when Generator Mode is enabled. UPS be derated to 60% when Generator Mode is enabled.	[Disable] [Enable]	Disable
	When the UPS input power source is a generator set the UPS will operate normally without transferring to Battery Mode when this is [Enable].	
Converter Mode UPS has no bypass when Converter Mode is enabled. This function can only be set before the UPS is on. UPS is derated to 60% when Converter Mode is enabled.	[Disable] [Enable]	Disable
	[Output Freq = 50Hz] [[Output Freq = 60Hz] (for [Enable])] Sets [Output Freq = 50Hz] [[Output Freq = 60Hz] to convert the input frequency to required output frequency.	
Outlet Switching	Bank On [Bankx] [Bank All] Sets Bank On directly. When the user sets Bank On, the bank output power will turn on directly.	Bank On
	Bank off [Bankx] [Bank All] Sets Bank Off directly. When the user sets Bank Off, the bank output power will turn off directly.	
	Bank Delay On [Bankx] [Bank All] Sets Bank On with delay. When the user sets Bank Delay On, the bank output power will turn on with delay.	
	Bank Delay Off [Bankx] [Bank All] Sets Bank Off with delay. When the user sets Bank Delay Off, the bank output power will turn off with delay.	
	Bank Reboot [Bankx] [Bank All] Sets Bank Reboot directly. When the user sets Bank Reboot, the bank output power will reboot directly.	
	Bank Delay Reboot [Bankx] [Bank All] Sets Bank Reboot with delay. When the user sets Bank Delay Reboot, the bank output power will reboot with delay.	
Reset Load Energy	[Reset] Reset Load Energy Consumption (KWH) value.	None
Reset ReplaceBAT	[Reset] Manually reset the Battery Replacement date.	None

USING THE UPS SYSTEM

3. SET UP

There are 29 UPS items that can be Set Up by the user.

1. Press the **UP** and **DOWN** buttons to select the **SET UP** icon.
2. Press the **ENTER** button to enter the **SET UP** function.
3. Press the **UP** and **DOWN** buttons to scroll to the **SET UP** option.
4. Press the **ENTER** button to select the **SET UP** submenu items shown in the table below.
5. Press the **ENTER** button to select the setting you want to set up.
6. The present **SET UP** parameter will be displayed by a blue color with a select mark in the front of setting parameters.
7. Press the **UP** and **DOWN** buttons to scroll through the different parameters.
8. Press the **ENTER** button to select the parameter you want to set.
9. You may be prompted **Save Change?** to save the selection, if so, press the **ENTER** button to save the setting. Some options are saved and started automatically. (See the following table and screen for additional details.)

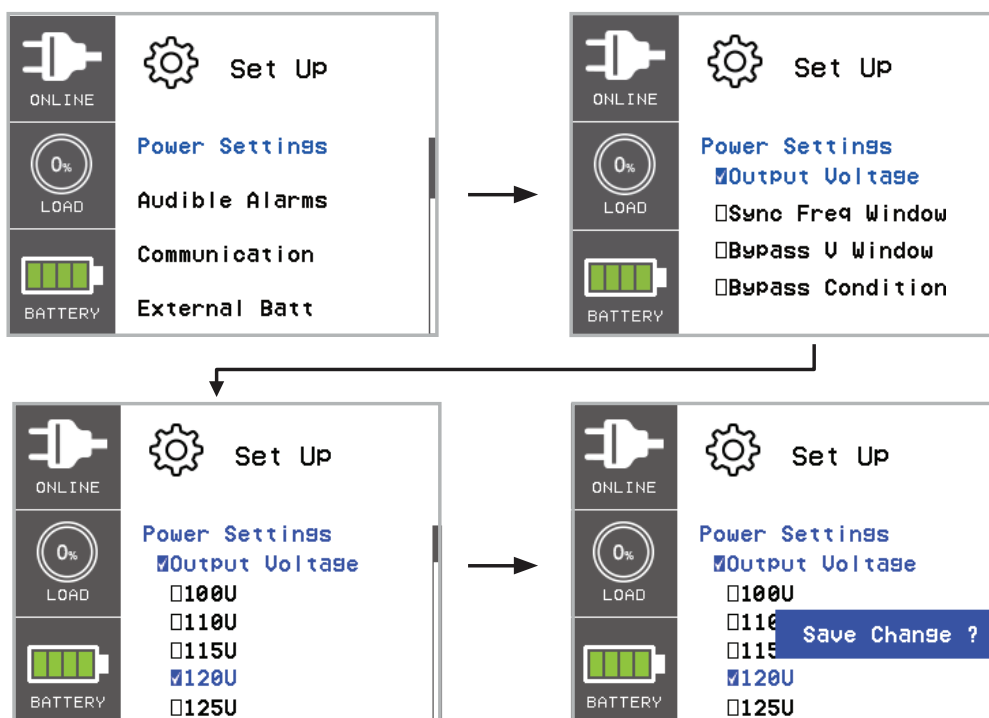

10. Press the **ESC** button to cancel or return to the previous **SET UP** menu.

USING THE UPS SYSTEM

SET UP ITEMS		AVAILABLE SETTINGS	DEFAULT SETTING
Power Setting	Output Voltage*	[100V*] [110V**] [115V**] [120V] [125V] Sets UPS output voltage	120V
	Sync Freq Window	Range= [+/- 1%] [+/- 2%] [+/- 3%] [+/- 4%] [+/-5%] [+/- 6%] [+/- 7%] [+/- 8%] [+/- 9%] [+/-10%] Sets output synchronization frequency range If input line frequency is outside this range, the UPS will lock in at the nominal frequency.	+/-5%
	Bypass Volt Window	Range= [+10%/-10%] [+10%/-15%] [+10%/-20%] [+15%/-10%] [+15%/-15%] [+15%/-20%] Sets Bypass Voltage range	+10%/-15%
	Bypass Condition	[Check Freq/Volt] [Check Volt Only] [No Bypass] Bypass Condition: The default setting [Check Freq/Volt] means the UPS will check the the following specifications (1) and (2) when UPS has fault and needs transfer to Bypass. The setting [Check Volt Only] means the UPS will check the the following specification (1) when UPS has fault and needs transfer to Bypass. (1) Bypass voltage is inside the range of "Bypass V Window". (2) Bypass frequency is inside the range of "Sync Freq Range". The setting [No Bypass] means the UPS is forbidden to transfer to Bypass when UPS has fault.	Check Freq/Volt
Audible Alarms		[Disable] [Enable] User can [Disable] or [Enable] the buzzer sound.	Enable
Communication	IP Address	[Mode:DHCP] [Mode:Manual]	Mode: DHCP
		[IP Address] [Subnet Mask] [Gateway] (for [Mode:Manual]) Select [Mode:Manual] to set [IP Address] [Subnet Mask] [Gateway] to network interface (RMCARD) or select DHCP to set automatically	None
	Signal Inputs	[Disable] [EPO] [ROO] Sets [EPO] (Emergency Power Off) to shutdown the UPS remotely when the contact is open. Sets [ROO] (Remote On/Off) to turn On the UPS remotely when the contact is close and turn Off the UPS remotely when the contact is open. The On/Off power button on front panel will be disabled when set to [ROO].	Disable
	Comm Setting	[Disable] [Enable] All communication ports on the UPS are [Disable] or [Enable].	Enable
External Batt		= [0] [1] [2] [3] [4] [5] [6] [7] [8] [9] [10] Sets the actual EBM (extended battery modules) number to get the correct estimated runtime.	0

*When set Output Voltage to [100V], UPS will be derated to 80%.

**When set Output Voltage to [110V] or [115V], UPS will be derated to 90%.

USING THE UPS SYSTEM

SET UP ITEMS		AVAILABLE SETTINGS	DEFAULT SETTING
Charger Function		[SBM] [Constant] Sets [SBM] to activate the Smart Battery Management to charge the batteries. Sets [Constant] to use trickle charge method to charge the batteries.	SBM
Charger Check		[Disable] [Enable] Sets [Disable] or [Enable] to constantly monitor the charger function.	Enable
Wiring Fault		[Disable] [Enable] Sets [Disable] or [Enable] the auto checking of Input wiring fault.	Disable
Button OFF LOCK		[Disable] [Enable] When [Enable] is set the Power ON/OFF Button is locked and will not function to prevent accidental UPS power ON/OFF operation.	Disable
Screen Saver		[Disable] [1 Minute] [5 Minutes] Sets the amount of time the LCD screen stays on after no user input. The [Disable] option keeps the LCD screen on at all times.	5 Minutes
Periodical Batt Test		[Disable] [1 week] [2 weeks] [3 weeks] [4 weeks] Sets the Periodical Time Battery Test	Disable
Batt Install Date		---/-- /-- Sets the date that the batteries were last replaced	None
Date & Time		---/-- /-- --:-- :-- Set Year/Month/Day Hour: Minute: Second to UPS or get Date & Time from PPBE (Agent) or RMCARD automatically.	None
Dry Relay Set		[I/P Power Fail] [Battery Low] [Summary Alarm] [UPS On Bypass] [UPS Fail]	UPS Fail
Low Batt Capacity*** *** The battery low alarm triggers when "Low Battery Threshold" or "Low Runtime Threshold" is reached.		[20%] [25%] [30%] [35%] [40%] [45%] [50%] [55%] [60%] [65%] When the UPS supplies battery power and the remaining capacity is lower than this threshold, the UPS will alert the software.	20%
Low Batt Runtime***		[0] [1] [2] [3] [4] [5] [.....] [26] [27] [28] [29] [30] min When the UPS supplies battery power and the remaining running time is lower than this threshold, the UPS will alert the software.	5
Power Restore During the UPS performs an autorestart process, when the conditions reach the setting of "Recharged Delay" and "Recharged Capacity" at the same time, the UPS will restore output.	Recharged Delay	[Instant] [1] [2] [3] [5] [10] [20] [30] [60] min When the utility power is restored, the UPS will start to recharge until the specified delay is expired before restoring output power.	Instant
	Recharged Capacity	[Instant] [15%] [30%] [45%] [60%] [75%] [90%] When the utility power is restored, the UPS will start to recharge until the specified battery capacity is met before restoring output power.	Instant

USING THE UPS SYSTEM

SET UP ITEMS		AVAILABLE SETTINGS	DEFAULT SETTING
Outlet Group	Turn On Delay	[Bankx] [Bank All] [Instant] [30sec] [1min] [2min] [3min] [5min] [10min] [20min] [30min] [60min] [120min] When the utility power is restored, the UPS will restore the output of this bank after the delay time is met.	Instant
	Turn Off Delay	[Bankx] [Bank All] [NeverOff] [Instant] [30sec] [1min] [2min] [3min] [5min] [10min] [20min] [30min] [60min] [120min] When supplying battery power, the UPS will power off this bank after this delay time is met.	NeverOff
	Turn Off Capacity	[Bankx] [Bank All] [NeverOff] [5] [10] [15] [20] [25] [30] [35] [40] [45] [50] [55] [60] [65] [70] [75] [80] [85] [90] [95] [100] % When supplying battery power, the UPS will power off this bank if the remaining battery capacity is lower than this threshold.	NeverOff
	Turn Off Runtime	[Bankx] [Bank All] [NeverOff] [1] [2] [3] [4] [5] [.....] [26] [27] [28] [29] [30] min When supplying battery power, the UPS will power off this bank if the remaining battery runtime is lower than this threshold.	NeverOff
Bank Schedule	Delay On Time	[Bankx] [Bank All] [Instant] [30sec] [1min] [2min] [3min] [5min] [10min] [20min] [30min] [60min] [120min] Set the bank delay time of user select. UPS turns on selected bank after the time be counted down from the setting to zero.	Instant
	Delay Off Time	[Bankx] [Bank All] [NeverOff] [Instant] [30sec] [1min] [2min] [3min] [5min] [10min] [20min] [30min] [60min] [120min] Set the bank delay time of user select. UPS turns off selected bank after the time be counted down from the setting to zero.	NeverOff
	Delay Reboot Time	[Bankx] [Bank All] [5] [10] [15] [20] [25] [30] [35] [40] [45] [50] [55] [60] sec Set the bank delay time of user select. UPS reboots selected bank after the time be counted down from the setting to zero.	5 sec

USING THE UPS SYSTEM

4. EVENT LOGS

1. Select **EVENT LOGS** Icons
2. Press the **ENTER** button to enter the **EVENT LOGS**.

EVENT DISPLAYED	DESCRIPTION
(xx) ----/--/-- :-- Event Content	Event date and time followed by event description.
EVENT ITEMS	AVAILABLE SETTINGS
Clear Event Log	[Activate?] Clears all the events stored in the LCD Control Panel Event Log.

3. Press the **UP** and **DOWN** buttons to scroll through the **EVENT LOGS**. The UPS will record events listed in the table below. (See the reference screen with No Event.)
4. If you want to clear the present Event Logs data, press the **UP** and **DOWN** buttons to scroll to the **Clear Event Logs** Option then press the **ENTER** button.
5. You may be prompted **Activate?** to act the selection, if so press the **ENTER** button to act the Clear Event Logs function.
6. Press the **ESC** button to return to the Main Menu.

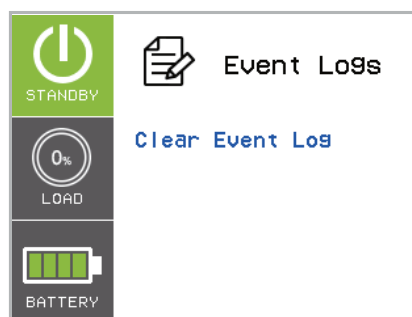
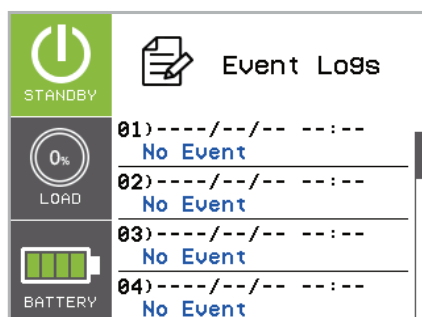

EVENT CONTENT	DESCRIPTION
High Output Voltage	The UPS has detected Inverter voltage too High.
Low Output Voltage	The UPS has detected Inverter voltage too Low.
Output short	The UPS has detected output short.
Bus Fault	The UPS has detected DC Bus too High or Low.
Over Temperature	The UPS has detected internal temperature too High.
Wiring Fault	The UPS has detected the input line/neutral wire are reversed or without ground wire.
Output Overload	The UPS has detected Output Watt or VA are too High.
Over Charge	The Battery has been charged too High voltage.
Charger Failure	The Battery Charger has malfunctioned.
Battery Low	The Battery has been discharged to low level.

USING THE UPS SYSTEM

EVENT CONTENT	DESCRIPTION
Load Over Set%	The UPS has detected Output Watt or VA has exceeded user set parameter.
Service Battery	The Battery Replacement Date has reached the maintenance period.
Battery Failure	The UPS has detected battery failure.
Line Abnormal	The UPS has detected the utility is out of range when the UPS is running auto-restart process.
Fan Error	The UPS has detected a fan malfunction.
BAT Disconnected	The UPS has not detected batteries.
Bypass Forbidden	User cannot use Manual Bypass function when Generator Mode or Converter Mode is enabled
Ready ON	The UPS has been turned on.
Battery Test	The Batteries have been tested.

5. ABOUT

There are ten UPS About items that can be tested by the user.

1. Select **ABOUT** Icons
2. Press the **ENTER** button to enter the **ABOUT**.
3. Press the **UP** and **DOWN** buttons to scroll through the **ABOUT** items shown in the table below.
4. Press the **ESC** button to return to the Main Menu.

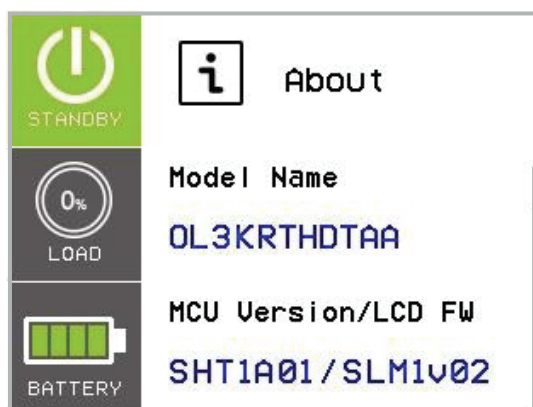

ABOUT ITEM	DATA DISPLAYED	DESCRIPTION
Model Name		Displays the UPS Model Name
MCU Version/LCD FW	XXXXX/XXXXX	Displays the UPS MCU and LCD Firmware Version
UPS Rating	XXXXVA/XXXXW	Displays the UPS Rating
Date and Time	----/--/-- --:--	Displays the present Date & Time
IP	XXXXXX	Display the network IP address
	XXX.XXX.XXX.XXX	
Subnet Mask	XXX.XXX.XXX.XXX	Display the network Subnet Mask
Gateway	XXX.XXX.XXX.XXX	Display the network Gateway
MAC	XX-XX-XX-XX-XX-XX	Display the network card MAC address
Next BATT Change	XXX / XXXX	Displays the next Battery Change Date & Time
Last BATT Test Date	XXXX/XX/XX	Displays the Last Battery Test Date & Time

USING THE UPS SYSTEM

6. DIAGNOSTICS

There are four UPS Diagnostic items that can be tested by the user.

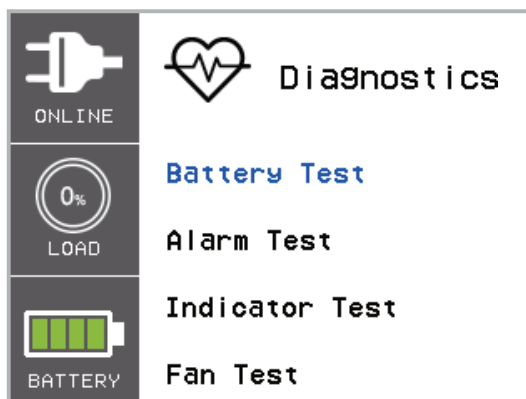

1. Select **DIAGNOSTICS** Icon.
2. Press the **ENTER** button to enter the **DIAGNOSTICS**.
3. Press the **UP** and **DOWN** buttons to scroll through the **DIAGNOSTICS** items shown in the table below.
4. You may be prompted **Activate?** to activate the selection, if so, press the **ENTER** button to activate the test function and the test will start automatically.
5. Press the **ESC** button to return to the Main Menu.



ITEMS	AVAILABLE SETTINGS	DESCRIPTION
Diagnostic	Battery Test The Battery Test may not perform if the UPS condition did not match the testing condition.	Starts a manual battery test, UPS will operate ten seconds on Battery mode to check battery condition.
	Alarm Test	Starts a manual Alarm test, buzzer will sound for five seconds.
	Indicator Test	Starts a manual Indicator test, UPS will change LCD color display to Yellow/Blue/Green and initialize the screen to WELCOME page then back to Main Menu.
	Fan Test	Starts a manual Fan test, UPS will operate fan with full speed five seconds.
	Activate?	

TROUBLESHOOTING

LCD will use a red or yellow color to indicate the Fault or warning status and also connect the color frame with the icon which has the same color and located on the left zone of the screen.

WARNING	ICON	POSSIBLE CAUSE	SOLUTION
Battery Mode		UPS is operating on battery power.	Save your data and perform a controlled shutdown.
Load Over XXX%		Your equipment requires more power than the setting in the Power Management Software (Power Panel Business) will allow.	Shut off the non-essential equipment or increase the level in the Power Management Software.
Wiring Fault		Line and neutral wires are reversed.	Exchange line and neutral wires.
		Missing ground wire.	Connect ground wire.
		No ground wire.	Disable Wiring Fault alarm on LCD panel.
		Line Abnormal	Utility power is out of range for the UPS to auto-restart.
Over Charge		Battery is overcharged.	Remove battery connector and check charger voltage.
Service Battery		The Battery Replacement Date has reached the recommended maintenance period.	If batteries have been recently replaced, then reset the Battery Replacement Date using PowerPanel Business software, RMCARD interface or through the LCD control panel on the UPS (See LCD Setting Configuration).

TROUBLESHOOTING

WARNING	ICON	POSSIBLE CAUSE	SOLUTION
Output Overload		Your equipment requires more power than the UPS can provide. If the UPS is in Line Mode, then it will transfer to Bypass Mode; if the UPS is in Battery Mode it will shutdown.	Shut off non-essential equipment. If this solves the overload problem, the UPS will transfer to normal operation.
Battery Low		UPS is operating on battery power and will be shutting down soon due to extremely low battery voltage.	UPS will restart automatically when acceptable utility power returns.
BAT Disconnected		Missing battery power.	Check battery connector and battery breaker
Battery Failure		UPS has failed in Battery Test.	Check battery connector and battery breaker. Contact technical support to replace the battery.
Output Short		Output short circuit.	Your attached equipment may have problems, please remove them and check again.
Over Temperature		High temperature sensor activates protection.	Check the fan for operation and if the ventilation hole has been covered.
Bypass Forbidden		Manual Bypass Forbidden when the LCD screen shows "Generator On" or "Converter On".	Slide the Interlock Bracket to the right. (For the Maintenance Bypass Module only)
EPO OFF	N/A	Missing the EPO connection.	Check the EPO connection.
Cold start Lock		UPS is locked to prevent consuming battery power during shipping.	Connect UPS to utility power for first-time operation.
Auto restart Lock		"Automatic Restore" is disabled in Power Management Software (PowerPanel Business)	Press "ON/OFF" button to turn on UPS or let the UPS auto restart by setting "Automatic Restore" to Enable via Power Management Software (PowerPanel Business) or RMCARD.
Charger Failure		Charger has failed.	Contact CyberPower for assistance.
High Output V		Output voltage is too high.	Shut down UPS and turn off input breaker. Contact CyberPower for assistance.
Low Output V		Output voltage is too low.	
Bus Fault		Internal DC bus voltage is too high or too low.	
Fan Error		Internal Fan has failed.	

MAINTENANCE

Storage

To store your UPS for an extended period of time, cover and store it with the battery fully charged. Recharge the battery every three months to ensure battery life.

Battery Replacement

Please read and follow the Safety Instructions before servicing the battery. Battery replacement should be performed by trained personnel who are familiar with the procedures and safety precautions. Make a note of the Replacement Battery part number. When replacing batteries, replace with the same type and number of batteries or battery packs.

Safety Precautions

	WARNING! HIGH VOLTAGE — RISK OF ELECTRIC SHOCK
--	---

Only use replacement batteries that are certified by Cyber Power Systems. Use of incorrect battery type is an electrical hazard that could lead to explosion, fire, electric shock, or short circuit. Batteries contain an electrical charge that can cause severe burns. Before servicing batteries, please remove any conductive materials such as jewelry, chains, wrist watches, and rings. Do not open or mutilate the batteries. Electrolyte fluid is harmful to the skin/eyes and may be toxic.

To avoid electric shock, turn off and unplug the UPS from the wall receptacle before servicing the battery. Only use tools with insulated handles. Do not lay tools or metal parts on top of the UPS or battery terminals.

Replacement Batteries

Please refer to the front side of the EBM for the model number of the correct replacement batteries. For battery procurement, go to www.CyberPowerSystems.com, or contact your local dealer. When the Replace Battery the LCD displays Service Battery, use PowerPanel Business software or log on to the RMCARD to perform a runtime calibration to verify battery capacity is sufficient and acceptable.

Battery Disposal

	DO NOT DISCARD IN HOUSEHOLD TRASH
--	--

Batteries are considered hazardous waste and must be disposed of properly. Contact your local government for more information about proper disposal and recycling of batteries. Do not dispose of batteries in fire. Cyber Power Systems encourages environmentally sound methods for disposal and recycling of its UPS products. Please dispose and/or recycle your UPS and batteries in accordance with local regulations.

BATTERY REPLACEMENT

Step 1: Remove the front panel and unscrew the battery access door. This screw is designed to be fixed on the door, do not remove it from the metal cover.

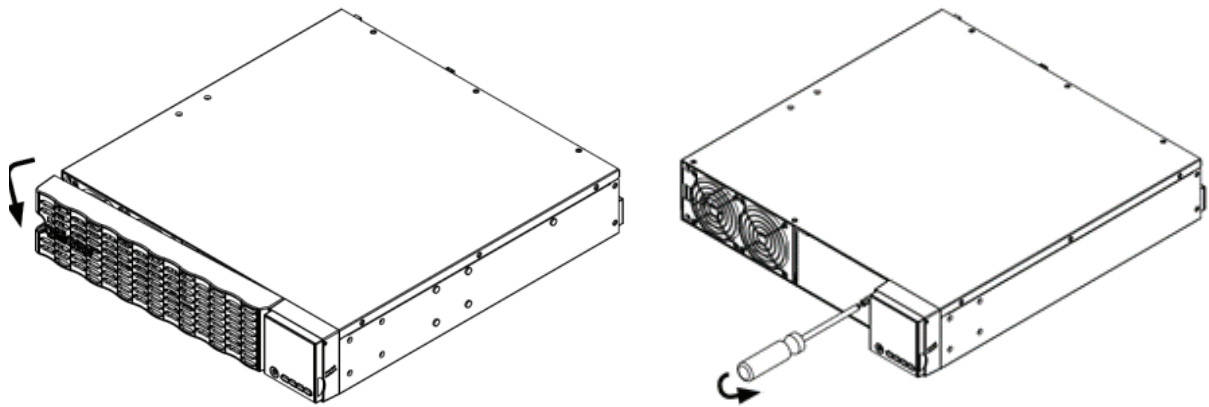

Step 2: Disconnect the internal battery connectors and unscrew the thumbscrew on the battery retention bracket and then remove it.

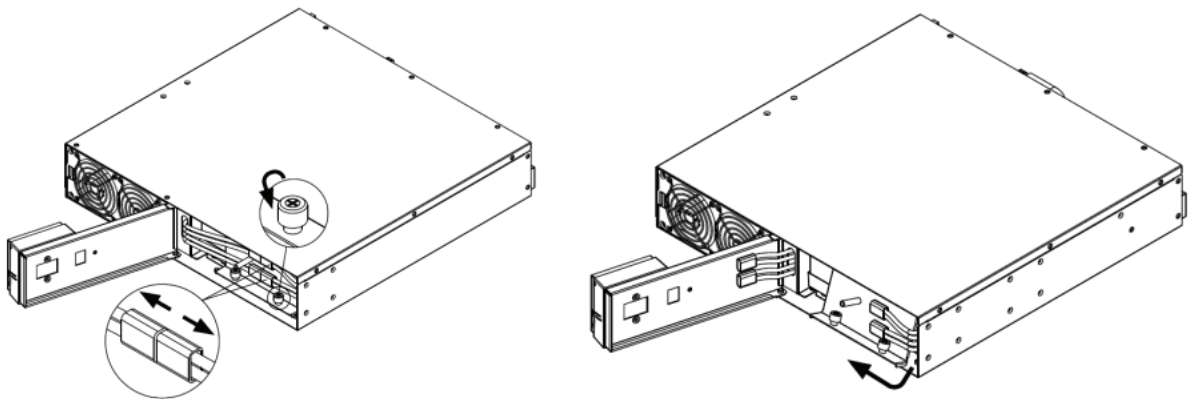

Step 3: Pull the battery trays out slowly and then put the new battery trays into the compartment.

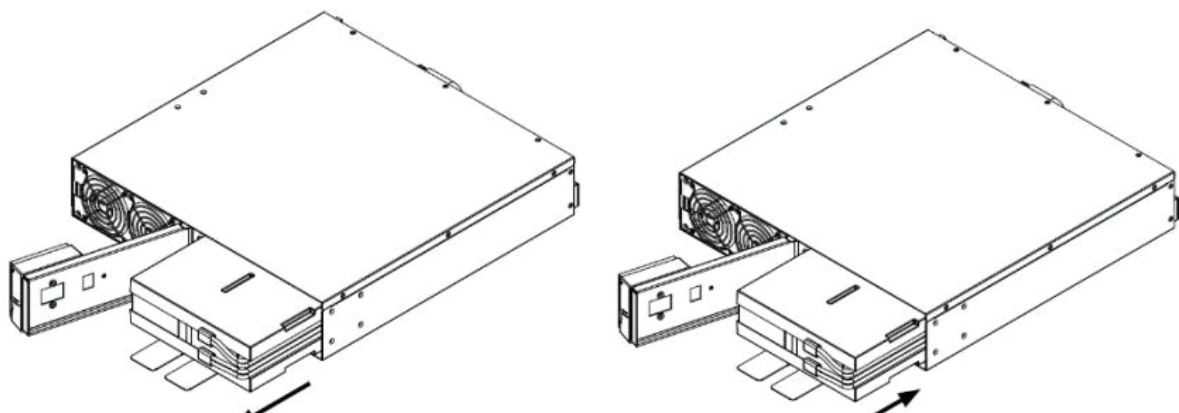

BATTERY REPLACEMENT

Step 4: Assemble the battery retention bracket and tighten the thumbscrew and assemble the battery retention bracket and tighten the thumbscrew. Connect the internal battery connector. Ensure that they are seated properly (connector will click into place).

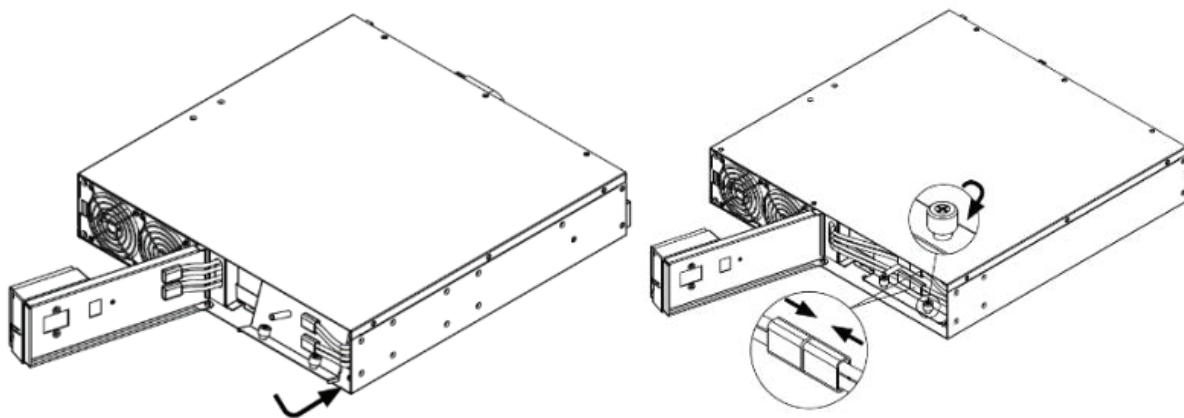

Step 5: Tighten the screw on the battery access door and install the front panel.

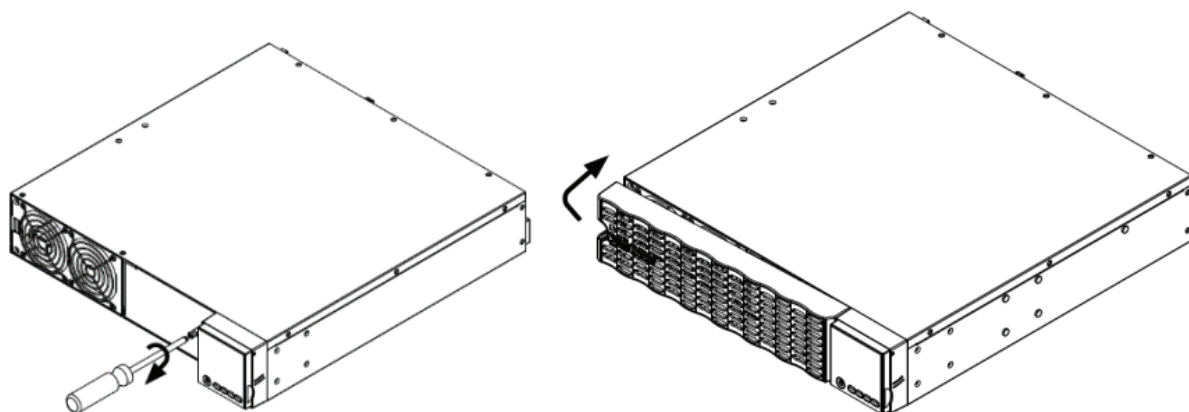

Step 6: Execute a battery test via the LCD control panel. To do this go to the Main Menu and select the Diagnostics Icon, then select Battery Test and Activate. After Battery test, go back to the Main Menu then select the Set Up icon, then select Batt Install Date to set the battery installation date. This operation can also be done via PowerPanel Business or the RMCARD web interface. Please see their respective User Manuals for detailed instructions.

TECHNICAL SPECIFICATIONS

MODEL	OL1KRTHDTAA	OL1K5RTHDTAA	OL2K2RTHDTAA	OL3KRTHDTAA
Configuration				
Capacity (VA)	1000	1500	2200	3000
Capacity (Watts)	1000	1350	1800	2700
Form Factor	Rackmount / Tower			
Energy-saving Technology	> 96.5%			
Input				
Input Power Plug	NEMA 5-15P	NEMA 5-15P	NEMA 5-20P	NEMA 5-30P
Input Voltage	100 - 125Vac			
Input Frequency	50 / 60Hz			
Input Power Factor	0.99			
Cold Start	Yes			
Output				
Output Waveform	Sine wave			
Output Voltage	100, 110, 115, 120, 125 Vac (Configurable) +/- 2%			
Output Frequency	50 / 60Hz (Auto-Sensing or Configurable) +/- 0.25Hz			
Transfer Time (Typical)	0ms			
Rated Power Factor	1.0	0.9	0.82	0.9
Harmonic Distortion	THD < 3% at Linear Load, < 5% at Non-linear Load			
Crest Factor	3 : 1			
ECO Mode Bypass Voltage Range	+/- 10%, +/- 15% (Configurable)			
Outlets	8 x NEMA 5-15R		6 x NEMA 5-20R 1 x NEMA L5-20R	6 x NEMA 5-20R 1 x NEMA L5-30R
Programmable & Controllable Outlets	(8) individually		(7) individually	
Protection				
Surge Protection	710 J			
Phone / Network Surge Protection	RJ11/RJ45 (One In/One Out)			
Overload Protection	Line Mode: 102 to 130% Load for 12 sec / 131 to 150% Load for 2 sec / >150% load 300ms Battery Mode: 102 to 130% Load for 12 sec / >130% Load for 2 sec Bypass Mode: 102% to 110% warning / 111% to 130% Load for 5 min / 131% to 150% 16 sec / >150% for 300 ms			
Short Circuit Protection	UPS Output Cut off Immediately or Input Fuse / Circuit Breaker Protection			
Battery				
Battery Size	12V / 9Ah			
Battery Quantity	3		4	
Battery Type	Sealed Lead-Acid Battery			
Recharge Time 0-90% (Typical)	4 hours			
Hot-Swappable	Yes			
LCD Screen	Multi-Function Color TFT-LCD readout that supports: (15) types of UPS Status / (7) types of Controls / (29) types of Set Up / Event Logs / (10) types About / (4) types Diagnostics			
Audible Alarms	Battery Mode / Battery Low / Overload / UPS Fault			

TECHNICAL SPECIFICATIONS

MODEL	OL1KRTHTDAA	OL1K5RTHDTAA	OL2K2RTHDTAA	OL3KRTHTDAA
Management & Communications				
On-Device Features	Start-up Self Test / Auto-Charge / Auto-Restart / Auto-Overload Recovery			
Connectivity Ports	1 x Serial Port (RS232) / 1 x USB Port / 1 x Dry Relay / 1 x EPO			
SNMP/HTTP Capable	Remote Management Card is optional			
Environment				
Operating Temperature	32°F to 104°F / 0°F to 40°C			
Operating Relative Humidity	0 to 90% non-condensing			
Software				
Power Management Software	PowerPanel® Business			
Physical				
Dimensions Length/Width/Height	17.05 x 3.41 x 14.96 in. / 433 x 86.5 x 380 mm		17.05 x 3.41 x 18.5 in. / 433 x 86.5 x 470 mm	
Net Weight	37.26 lbs. / 16.9 kg		50.93 lbs. / 23.1 kg	
Certifications				
Safety	UL 1778 / CSA C22.2 No. 107.3 FCC Part 15 Class B		UL 1778 / CSA C22.2 No. 107.3 FCC Part 15 Class A	
Environmental	RoHS Compliant			

PRODUCT REGISTRATION

Thank you for purchasing a CyberPower product. This UPS is designed to provide unsurpassed power protection, operation, and performance during the lifetime of the product. Please take a few minutes to register your product at: www.CyberPowerSystems.com/registration.

Registration certifies your product's warranty, confirms your ownership in the event of a product loss or theft, and entitles you to free technical support. Register your product now to receive the benefits of CyberPower ownership.

CYBERPOWER GREENPOWER UPS™ TECHNOLOGY

Advanced Energy-Saving Design

The GreenPower UPS™ has a high-efficiency charger, which makes it the most energy-efficient UPS in its class. The advanced high-frequency charging system significantly improves charging efficiency and conserves energy. As a result of this advanced design, the GreenPower UPS™ uses less energy compared to competitive models. The GreenPower UPS™ is manufactured in accordance with the Restriction on Hazardous Substances (RoHS) directive making it one of the most environmentally-friendly UPS systems on the market today.



FCC COMPLIANCE STATEMENT

This device complies with part 15 of the FCC Rules. Operation is subject to the following two conditions: (1) This device may not cause harmful interference, and (2) this device must accept any interference received, including interference that may cause undesired operation.

Warning: Changes or modifications not expressly approved by the party responsible for compliance could void the user's authority to operate the equipment. This document is believed to be accurate, but CyberPower reserves the right to change or correct the contents and does not assume any responsibility for omissions or errors.

For 2200 and 3000VA Online UPS Models:

NOTE: This equipment has been tested and found to comply with the limits for a Class A digital device, pursuant to part 15 of the FCC Rules. These limits are designed to provide reasonable protection against harmful interference when the equipment is operated in a commercial environment. This equipment generates, uses, and can radiate radio frequency energy and, if not installed and used in accordance with the instruction manual, may cause harmful interference to radio communications. Operation of this equipment in a residential area is likely to cause harmful interference in which case the user will be required to correct the interference at his own expense.

The Class A digital apparatus meets all requirements of the Canadian Interference-Causing Equipment Regulation. Cet appareil numérique de la class A respecte toutes les exigences du Règlement sur le matériel brouilleur du Canada.

Canadian Compliance Statement

CAN ICES-3(A)/NMB(A)

Shielded signal cables must be used with this product to ensure compliance with the Class A FCC limits.

For 1000 and 1500VA Online UPS Models:

NOTE: This equipment has been tested and found to comply with the limits for a Class B digital device, pursuant to part 15 of the FCC Rules. These limits are designed to provide reasonable protection against harmful interference in a residential installation. This equipment generates, uses, and can radiate radio frequency energy and, if not installed and used in accordance with the instructions, may cause harmful interference to radio communications. However, there is no guarantee that interference will not occur in a particular installation. If this equipment does cause harmful interference to radio or television reception, which can be determined by turning the equipment off and on, the user is encouraged to try to correct the interference by one or more of the following measures:

- Reorient or relocate the receiving antenna.
- Increase the separation between the equipment and receiver.
- Connect the equipment into an outlet on a circuit different from that to which the receiver is connected.
- Consult the dealer or an experienced radio/TV technician for help.

Canadian Compliance Statement

CAN ICES-3 (B)/NMB-3(B)



LIMITED WARRANTY AND CONNECTED EQUIPMENT GUARANTEE

Please visit www.CyberPowerSystems.com for a copy of the Limited Warranty and Connected Equipment Guarantee.

Where Can I Get More Information?

The application of the United Nations Convention of Contracts for the International Sale of Goods is expressly excluded. CyberPower is the warrantor under this Limited Warranty. For further information please feel free to contact CyberPower at: Cyber Power Systems (USA), Inc. 4241 12th Ave E., STE 400, Shakopee, MN 55379; call us at (877) 297-6937; or submit a web ticket online at cyberpowersystems.com/support.

Cyber Power Systems (USA), Inc. encourages environmentally sound methods for disposal and recycling of its UPS products. Please dispose and/or recycle your UPS and batteries in accordance to the local regulations of your state.

WARNING: This product can expose you to chemicals including bisphenol A (BPA) and styrene, which is known to the State of California to cause reproductive harm and cancer. For more information, go to www.P65Warnings.ca.gov.