

Installation Instructions for 2800 & 2900 Series Leversets

(Purchase tubular latch separately)

Step 1.

- Fold template where indicated.
- Position template on door edge at desired latch height.
- Firmly hold template and mark latch height and 5 hole centres (4 off 9mm & 1 off 35mm) at required backset.
- Measure door thickness and mark centre.
- Drill 25mm latch hole.
- **Note:** it is important to drill this hole squarely.
- Drill Pilot holes - suggest 3mm, then enlarge (4 off) 9mm holes & (1 off) 35mm holes from both sides of the door.

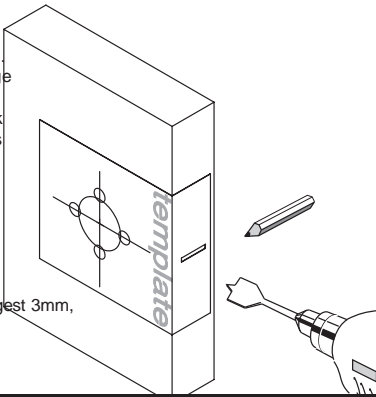

Important Note: Do not drill 35mm hole if using privacy adaptor with this leverset. A privacy adaptor requires a 44mm diameter hole. See privacy adaptor installation instruction and template before commencing any drilling.

Step 2.

- Mark and chisel door edge for faceplate.
- Chisel the recess to a depth that allows latch to sit flush with door edge.
- Use latch faceplate as a template.
- Insert latch & fasten with wood screws provided.

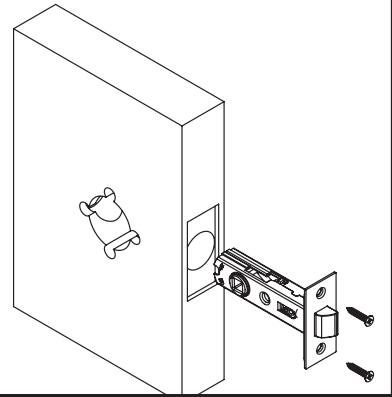

Important Note: Use in conjunction with Gainsborough 480 or 960/980 Series Dual Sprung Tubular Latch – purchase separately.

Step 3.

Install lever assemblies to door:

- Insert square drive spindle (1) through latch in door.
- Identify which side of the door each lever assembly will need to be located to allow both levers to move in a downward motion once installed.
- Remove rosette covers (2a or 2b) from both lever assemblies.
- Place lever assembly (3) with latch alignment posts (4) onto the square drive spindle.
- Place other lever assembly (5) into position, locating it onto the other end of spindle.
- Fasten both lever assemblies together with screws (7) & tube nuts (8) provided: Use long screws for thick doors and short screws for thin doors.
- Install screws (7) from internal side, through the vertical countersunk holes (6), and into the tube nut hole (8) of the opposite under-rose. Then tighten both screw heads.

2900

- Reapply rosette covers (2a) to both under-roses by pushing the covers over the rubber rings until flush with door. (Ensure tabs at bottom of under-rose match cut-out in rosette covers).

2800

- Reapply rosette covers (2b) to both under-roses by pushing the covers over the rubber rings until flush with door. The *grub-screw, which is already located in the rosette cover, should be on the lower face.

- Check the rosette covers are square with the door edge. Fasten in place with

*grub-screw using allen key (9) provided.

*Note: Grub-screw is already located in the rosette cover.

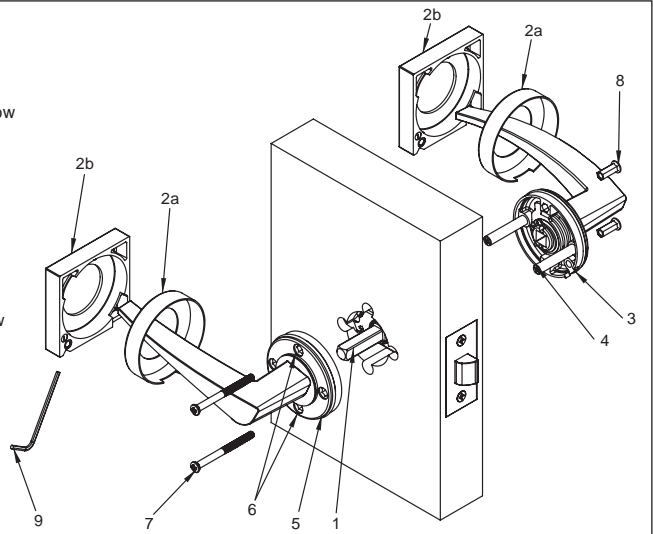

NOTE: Carefully follow these instructions when installing. Screws to be tightened to a recommended 2.5Nm torque.

Important Note:

Do not drill 35mm hole if using privacy adaptor with this leverset. A privacy adaptor requires a 44mm diameter hole. See privacy adaptor installation instruction and template before commencing any drilling.

Mark centre-line of latch hole

Mark centre-line of latch hole

Important Notes: Warranty void if installed with latch alignment posts removed for latch application. Mortice lock and privacy adaptor applications excluded. For installation with mortice locks and privacy adaptors latch alignment posts are required to be removed. Refer to mortice lock and privacy adaptor instructions for drilling

FOLD HERE

Fit here on door edge

Important Note
Drill 9.0mm holes before 35mm hole for ease of drilling

9mm hole (drill first)

35mm hole (drill second)

BACKSET 60mm

BACKSET 70mm

Fit here on door edge

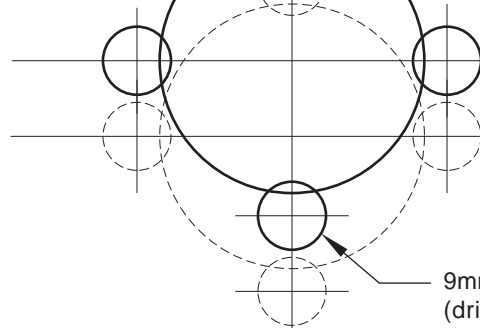

9mm hole (drill first)

Installation template for passage applications

