

INSTRUCTION MANUAL



30" Square Bar Table
SKU: OP7006

V1.0

! NOTICE

Do not overtighten screws. (Insert all screws before tighten screws.)

- Please do not exceed the weight limitations of this item.
- Do not stand on or use any part of this item as a step ladder.
- Firmly secure all bolts, screws and nuts before use.
- Reconfirm that all bolts, screws, and nuts are secure every 90 days.
- Do not use or store this item in the proximity of open flame or flammable/combustible chemicals.
- Be aware that some parts are heavy and have sharp edges.
- Please adjust the speed slowly when you use electric drill for assembling to avoid screw slippage.

TOOLS REQUIRED

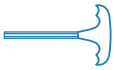

ALLEN WRENCH
(PROVIDED)



WRENCH
(PROVIDED)



TABLE
300 LBS
CAPACITY



1 PERSON
ASSEMBLY



UP TO 20MIN.
ASSEMBLY

HARDWARE

1

M6.3 x70mm
BOLT



16 PCS

2

M6.3 x80mm
BOLT



16 PCS

3

M6 x90mm
BOLT



4 PCS

4

M6 x100mm
BOLT



4 PCS

5

M6 NUT



8 PCS

6

M6 WASHER



8 PCS

7

ALLEN
WRENCH

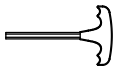

1 PC

8

WRENCH

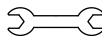

1 PC

PARTS

A

TABLE TOP

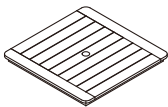

1 PC

B

TABLE LEG I



2 PCS

C

TABLE LEG II

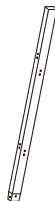

2 PCS

D

SHORT RAIL



4 PCS

E

LONG RAIL



4 PCS

PRODUCT ASSEMBLY-OVERALL VIEW

1

Look at following overall view of this table and exact position of each parts to be assembled.

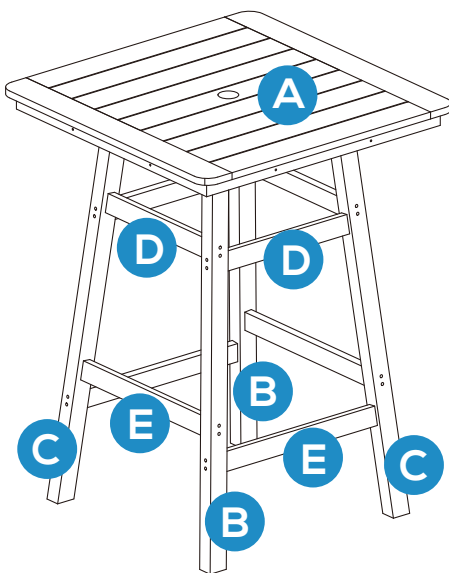

PRODUCT ASSEMBLY

1

Attach part B Table leg I to part A Table top with 4 pcs of Hardware 3 Bolt, 5 nut and 6 washer.

Notice: Please put the B Table leg I to the posit on with "B Table leg I" sticker on Table Top

Attach part C Table leg II to part A Table top with 4 pcs of Hardware 4 Bolt, 5 nut and 6 washer.
Do not tighten screws too much at this step.

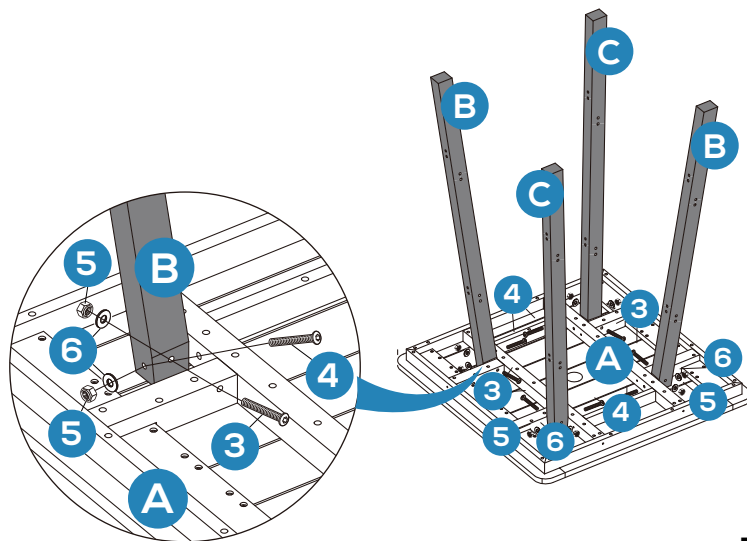

PRODUCT ASSEMBLY

2

Attach part D Short rail to part B&C Table leg with 4 pcs of Hardware 1 Bolt in **the narrow side** of table leg
Attach part D Short rail to part B&C Table leg with 4 pcs of Hardware 2 Bolt in **the wide side** of table leg
Do not tighten screws too much at this step.

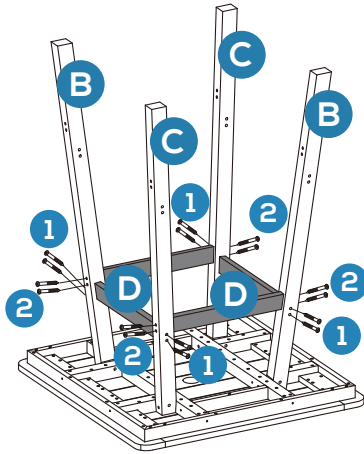

Please pay attention of
the narrow side and wide side
on the table leg before installation

3

Attach part E Long rail to part B&C Table leg with 4 pcs of Hardware 1 Bolt in **the narrow side** of table leg.
Attach part E Long rail to part B&C Table leg with 4 pcs of Hardware 2 Bolt in **the wide side** of table leg
Do not tighten screws too much at this step.

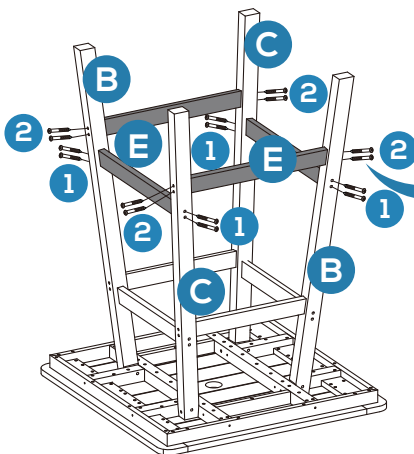

Please pay attention of
the narrow side and wide side
on the table leg before installation

PRODUCT ASSEMBLY

4

Check and tighten all the bolts and screws again and finish the assembly.

