

Model 540 Ergonomic Mesh Chair

Parts Listing

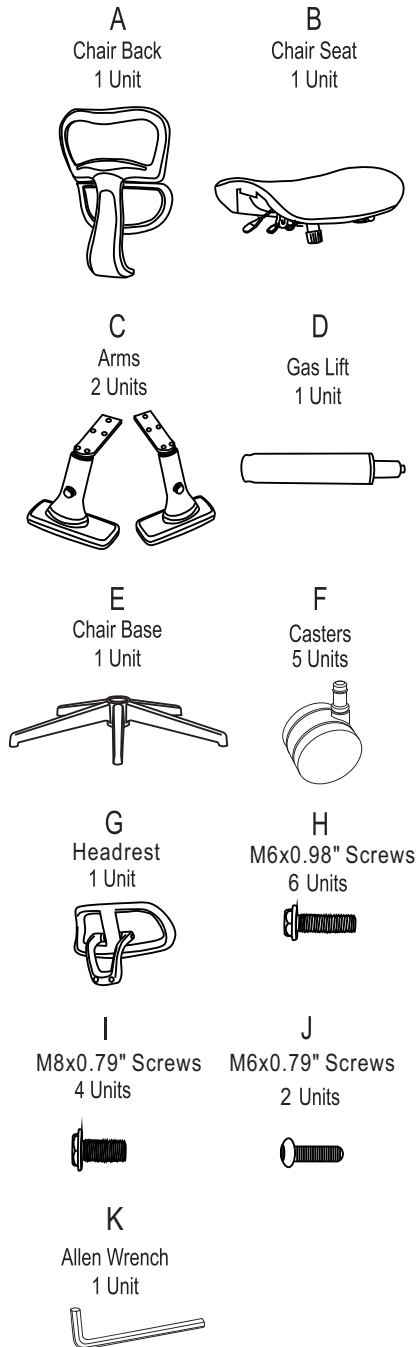

Assembly Instructions



Tools Needed: Allen Wrench - Provided
Please read all instructions before assembly.

- Step 1:** Insert Casters (F) into Chair Base(E). Insert Gas Lift(D) into the hole in the center of the Base(E).
- Step 2:** Attach Arms (C) to both sides of the chair Seat(B) using M6 x 0.98" Screws(H). Tighten with Allen Wrench(K).
- Step 3:** Attach Chair Back (A) to Chair Seat(B) using four M8x0.79" Screws(I) as shown. Tighten with Allen Wrench(K).
- Step 4:** Carefully place the assembled Chair Frame onto the Gas Lift(D). Aligning the hole in the Seat Mechanism on the Chair Seat(B) with the Gas Lift(D). Press down on the Chair Seat(B) to secure in place.
- Step 5:** Attach Headrest(G) to Chair Back(A), using two M6 x 0.79" Screws(J). Tighten with Allen Wrench(K).

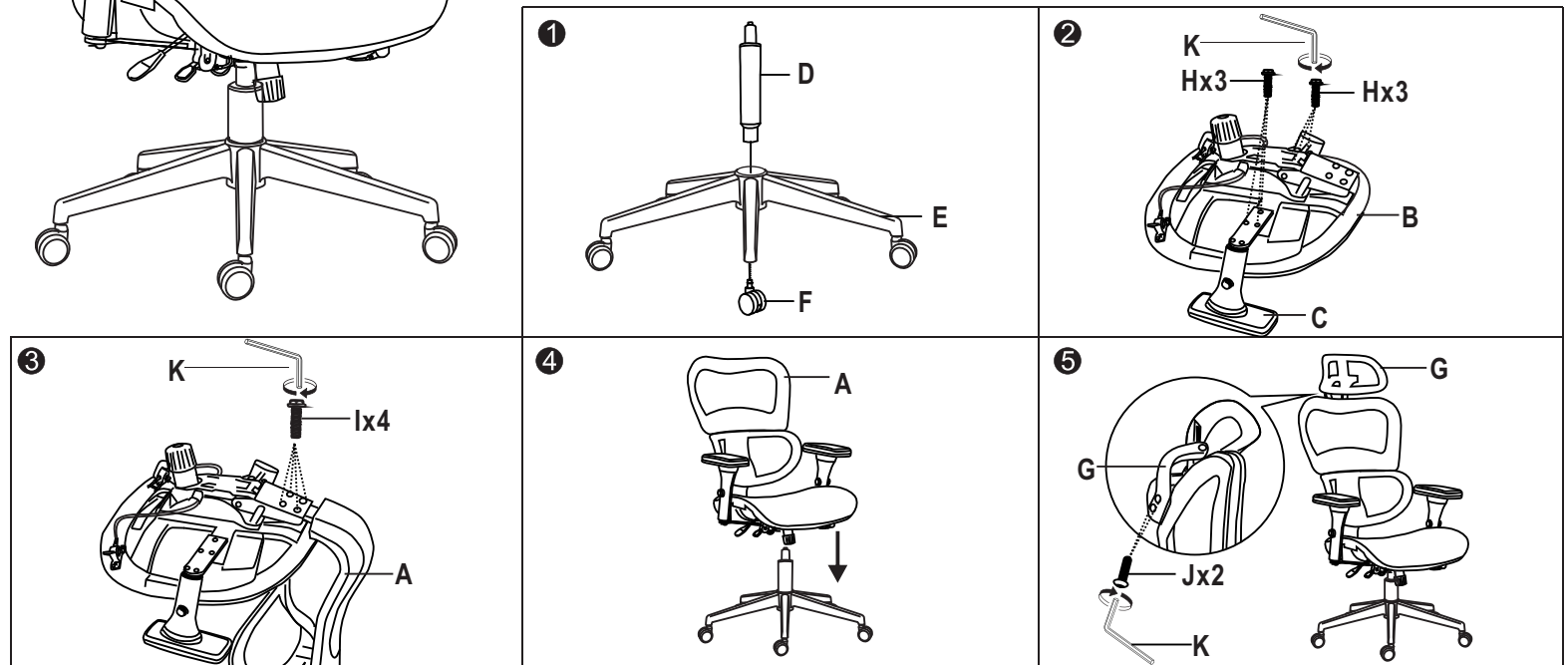

WEIGHT CAPACITY: 275 lbs.

Assembly Notes:

During assembly, hand tighten screw only when all screws are in place, you may then tighten all screws completely.

CAUTION:

1. Do not use this chair as a step ladder.
2. Check for loose screws and tighten them every 6 months.

161 Tradition Trail Holly Springs, NC, 27540
800-520-7471 (voice) 919-362-4765 (fax)
919-303-6389 (voice) www.ofminc.com
support@ofminc.com