

Item # : CH30MAROT

Assembly Instructions

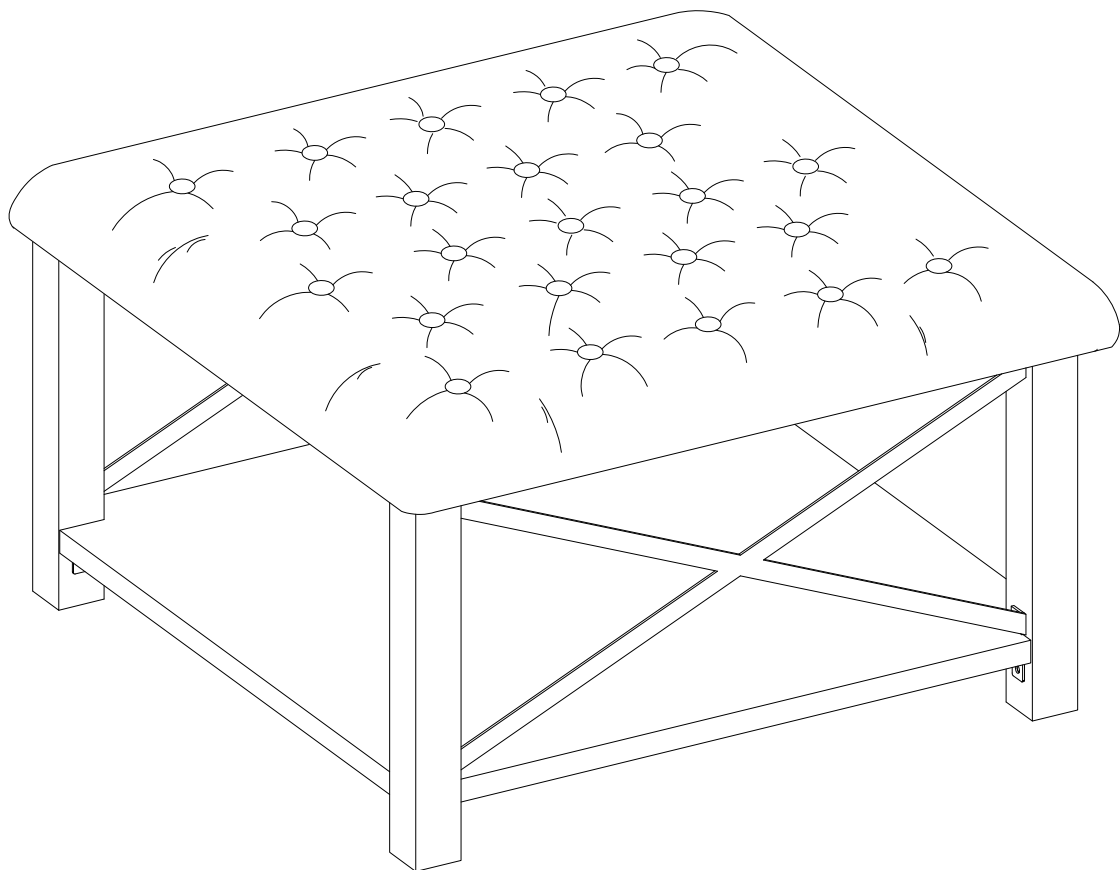

Walker Edison®

Please visit our website for the most current instructions, assembly tips, report damage,
or request parts. www.walkeredison.com

Revised 20/06/2019(L)

General Assembly Guidelines

- I. Ensure that all parts and hardware are available before beginning assembly.
- II. Follow each step carefully to ensure the proper assembly of this product.
- III. Two people are recommended for ease in the assembly of this product.
- IV. The three main types of hardware used to assemble this product are: wood dowels, screws and bolts.
- V. The provided glue is to secure wood dowels in place. When first inserting dowels, locate the appropriate hole for the dowel, place a small amount of glue in the hole and insert the dowel. Wipe away excess glue immediately.

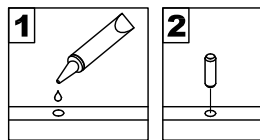

In future assembly steps when dowels are necessary to attach assembly parts together, place a small amount of glue on the end of the dowel before attaching parts together. Wipe away excess glue immediately.

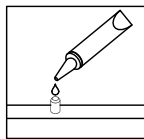

- VI. A Phillips head screwdriver is required for the assembly of this product .

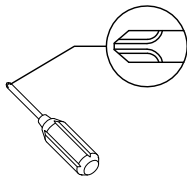

- VII. Power tools should not be used to assemble this product.

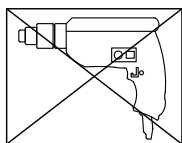



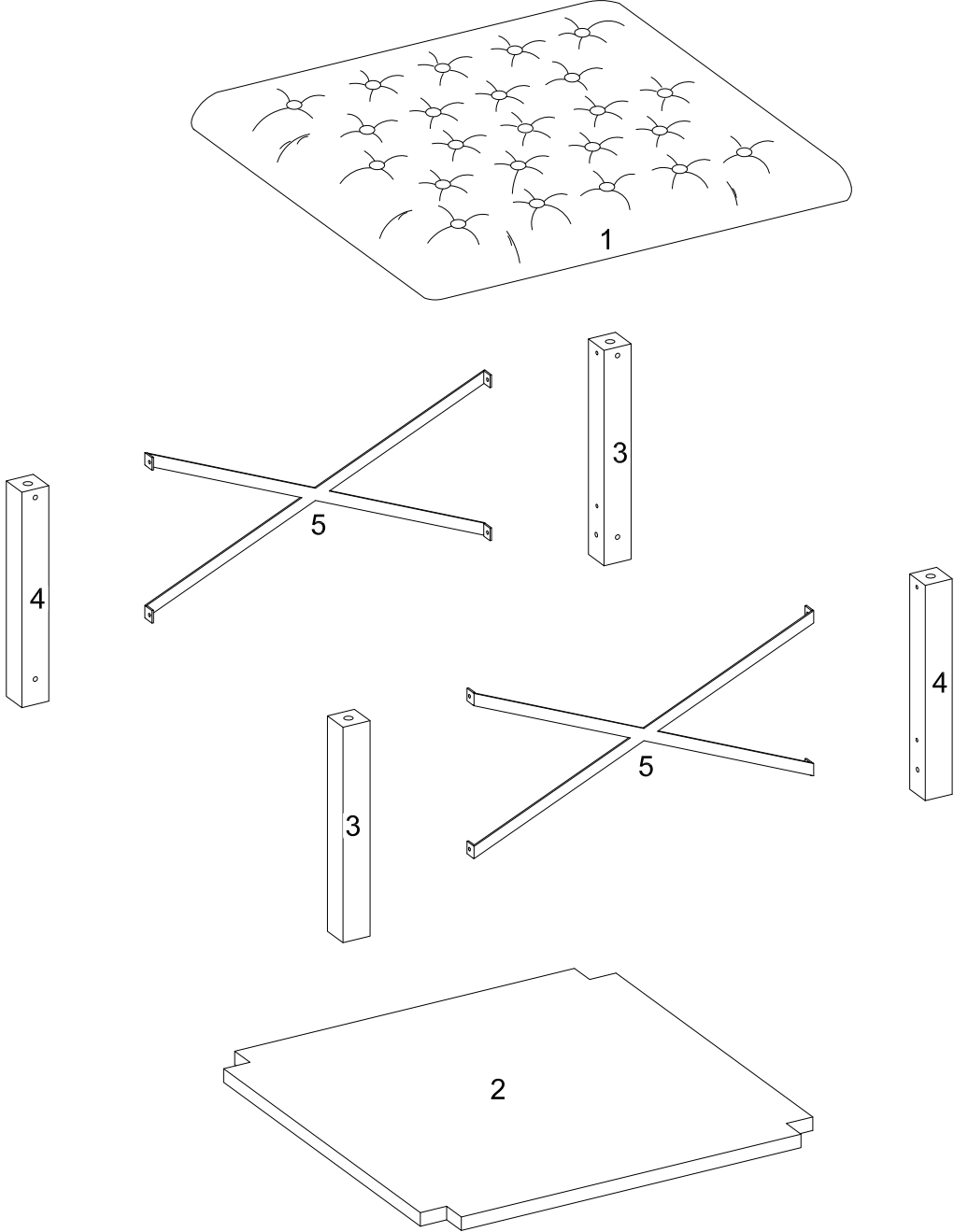

- VIII. Drill may be needed for securing product to wall.

Parts List

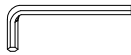

Hardware List

A		Ø12x40mm	Wooden dowel	4 pcs
B		M6x15	Bolt	32 pcs
C			L type connector	12 pcs
D		M 4	Hex Key	1 pcs
E			Glue tube	1 pcs

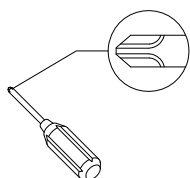

Philips head screwdriver required for assembly
(not included)

*The hardware quantities listed above are required for proper assembly.
Some extra hardware may also have been included.*

Step 1

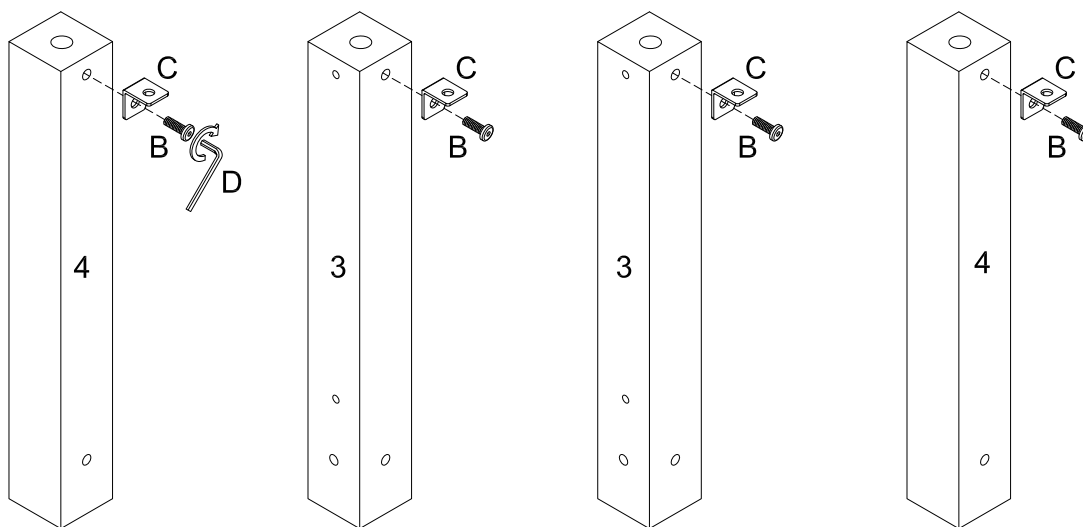

Using bolt (B) secure L type connector (C) into parts (3,4) with hex key (D) as per diagram.

Step 2

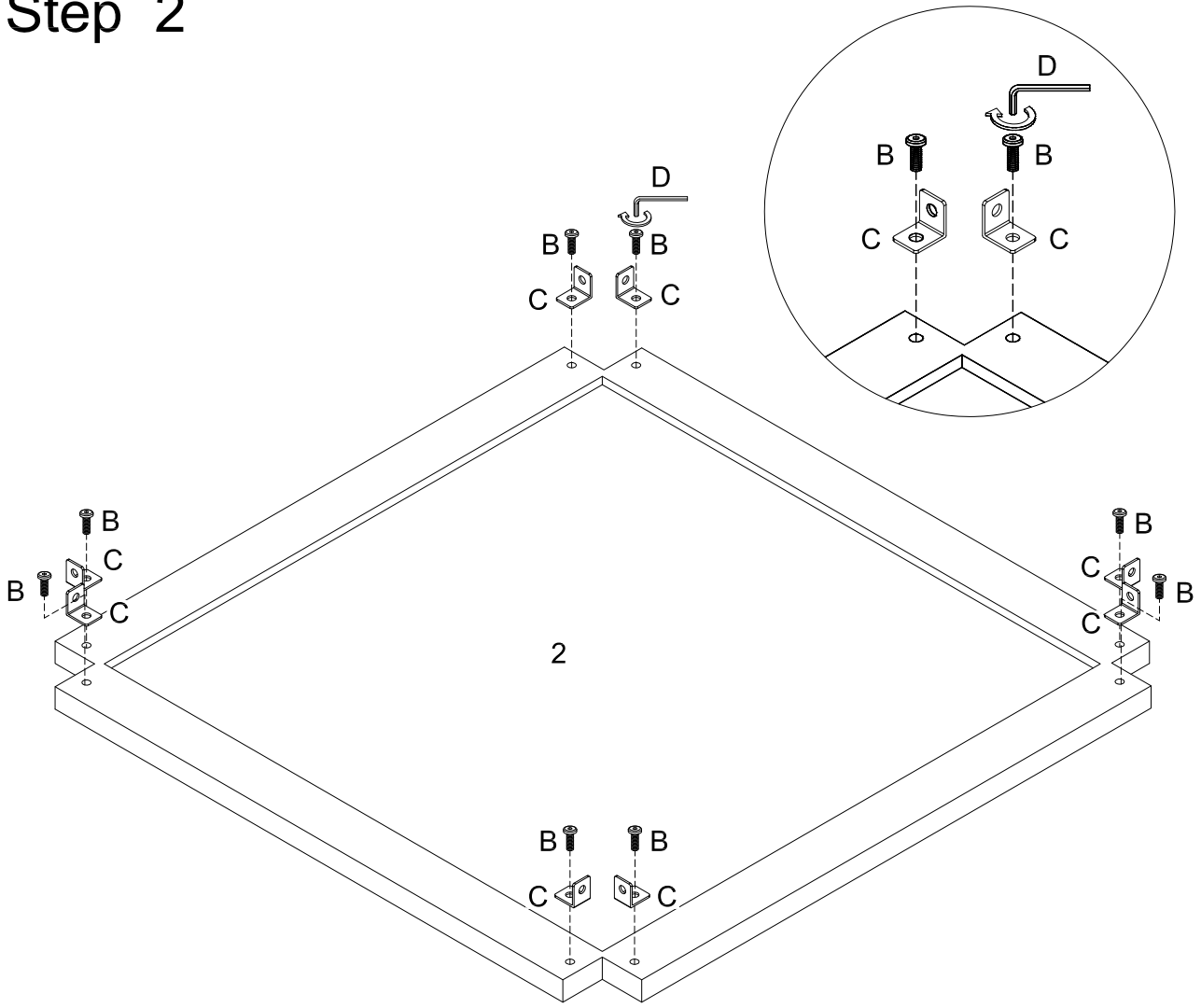

Using bolt (B) secure L type connector (C) into part (2) with hex key (D) as per diagram.

Step 3

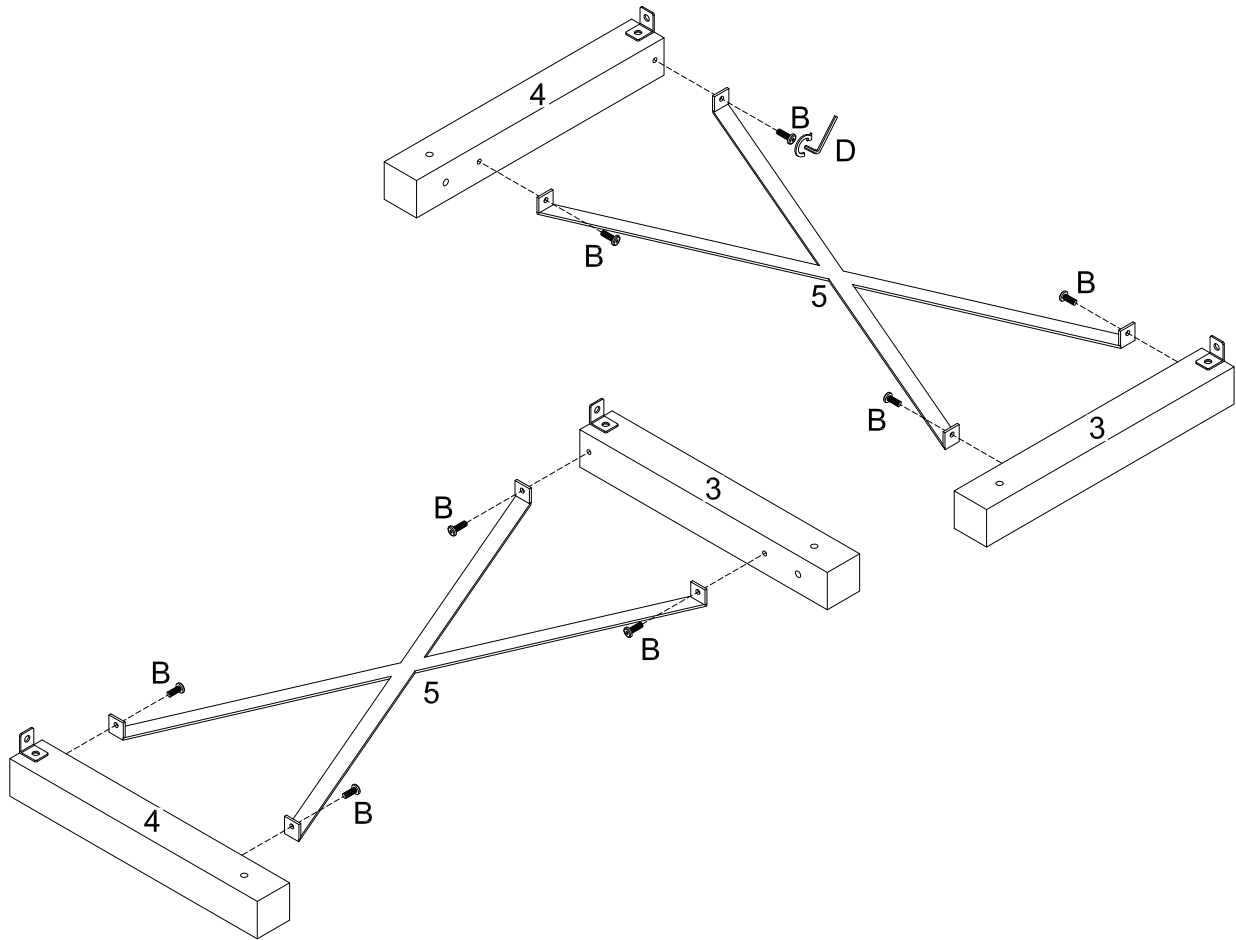

Using bolt (B) secure part (5) into parts (3,4) with hex key (D) as per diagram.

please do not fully tighten the bolts when assemble this step ,otherwise it may caused the next step can not be assembled.

Step 4

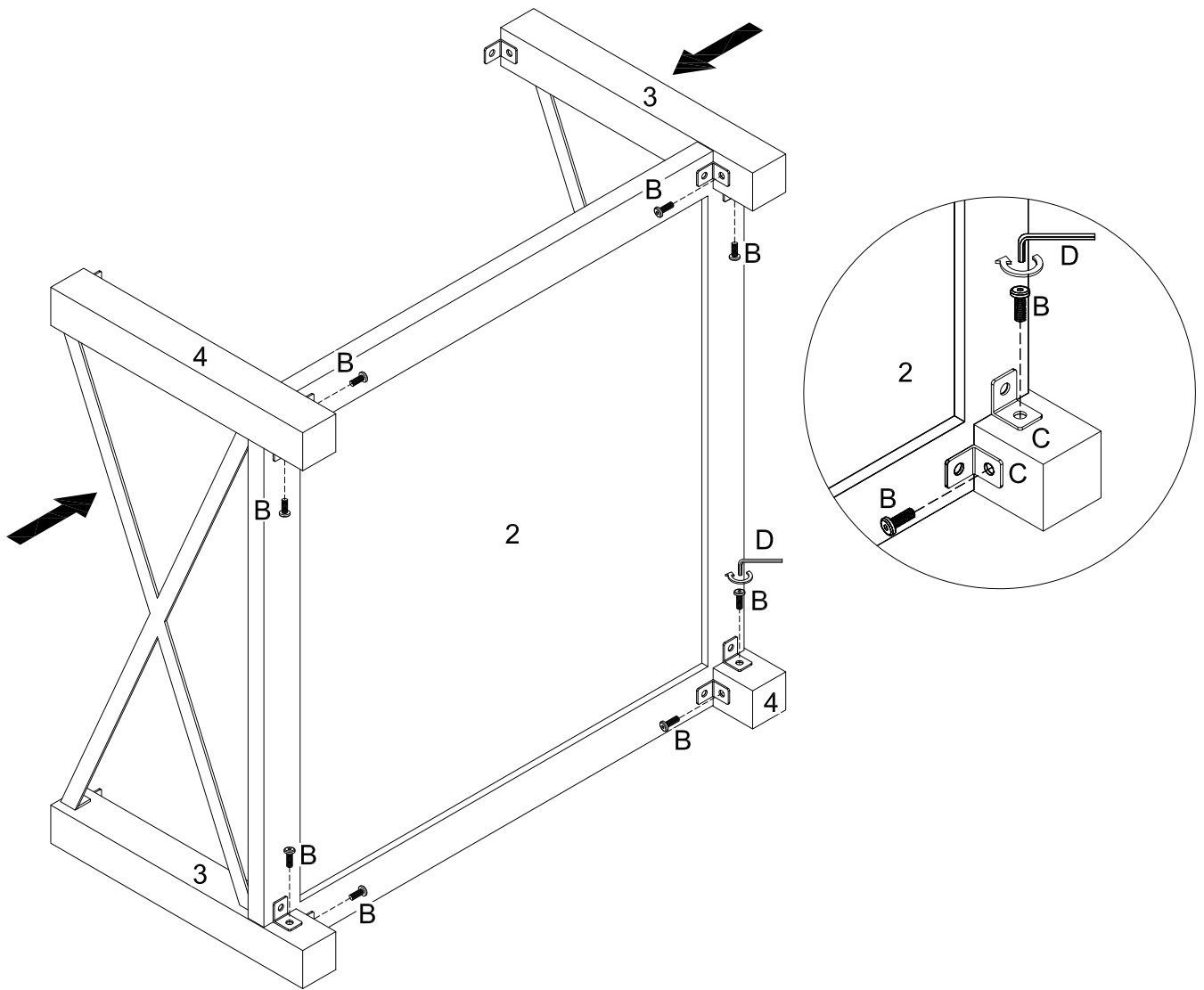

Using bolt (B) secure L type connector (C) into parts (2,3,4) with hex key (D) as per diagram.

Step 5

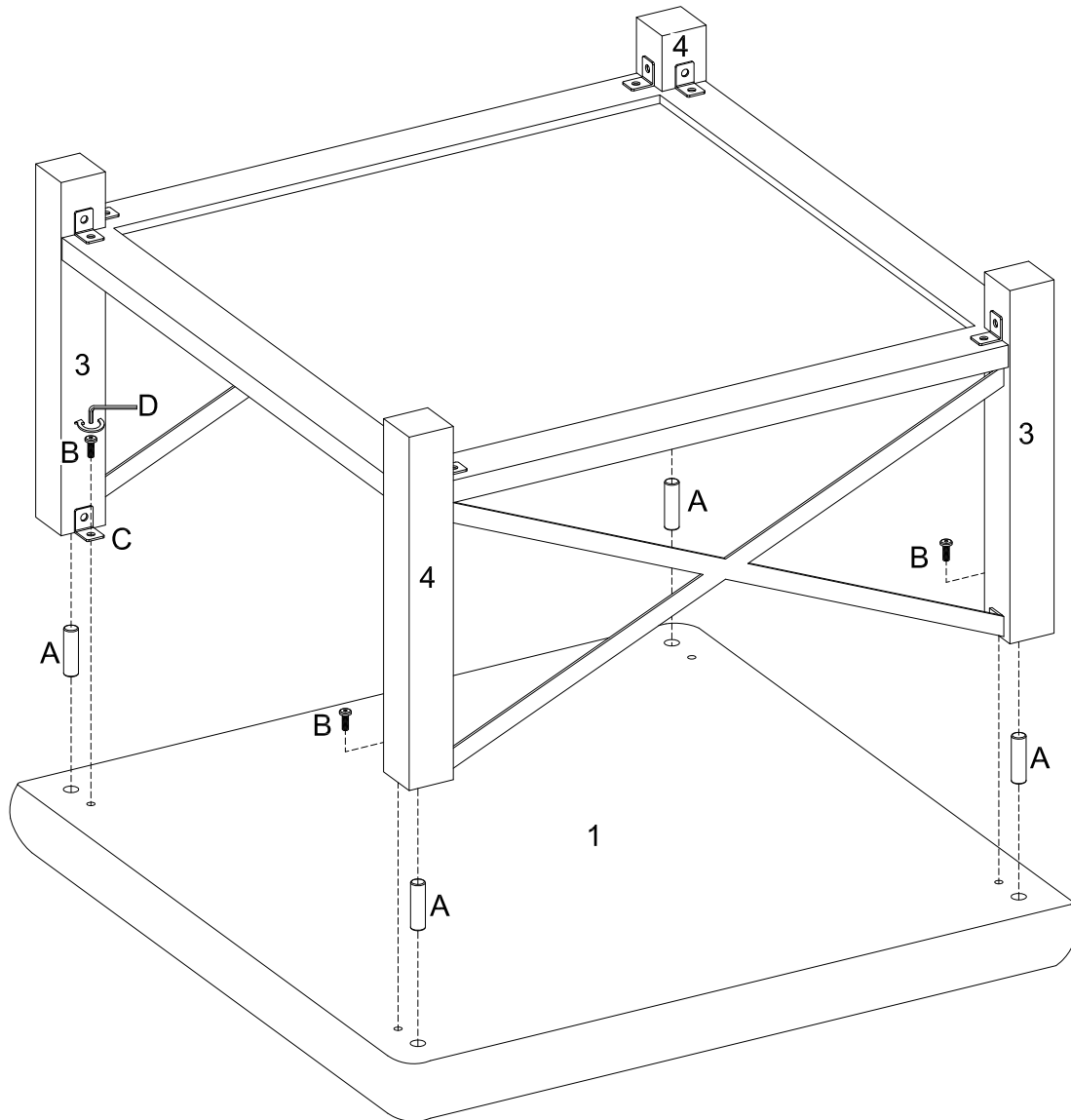

Insert wooden dowel (A) into part (1) ,using bolt (B) secure L type connector into parts (3,4) to part (1) with hex key (D) as per diagram.

Step 6

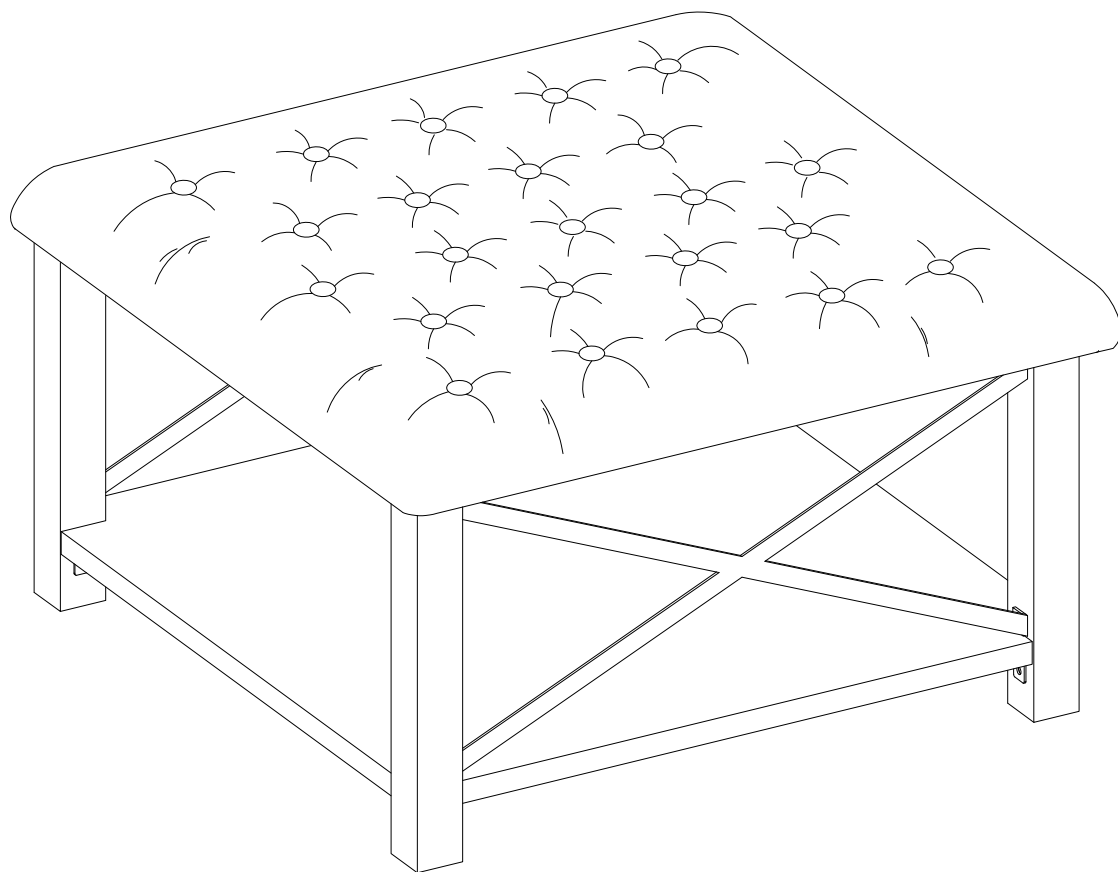

Adjust any parts out of alignment and tighten all bolts.

Final Assembly