

CONVERSION TABLES

Inch Pounds (in.lbs)	Kilo-gram Meters (Kgm or mkg)	Newton Meters (Nm)	Newton Meters (Nm)	Inch Pounds (in.lbs)	Kilo-gram Meters (Kgm or mkg)	Kilo-gram Meters (Kgm or mkg)	Newton Meters (Nm)	Inch Pounds (in.lbs)
60	0.69	6.78	10	88.56	1.02	1	9.81	86.76
120	1.38	13.56	20	177.00	2.04	2	19.61	173.64
180	2.07	20.34	30	265.56	3.06	3	29.42	260.40
240	2.76	27.12	40	354.00	4.08	4	39.23	347.16
300	3.46	33.90	50	442.56	5.10	5	49.04	434.04
360	4.15	40.68	60	531.12	6.12	6	58.84	520.80
420	4.84	47.46	70	619.56	7.14	7	68.65	607.56
480	5.53	54.24	80	708.12	8.16	8	78.46	694.44
540	6.22	61.02	90	796.56	9.18	9	88.26	781.20
600	6.91	67.80	100	885.12	10.20	10	98.07	867.96
660	7.60	74.58	110	973.68	11.22	11	107.88	954.84
720	8.29	81.36	120	1,062.12	12.24	12	117.68	1,041.60
780	8.98	88.14	130	1,150.68	13.26	13	127.49	1,128.36
840	9.67	94.92	140	1,239.12	14.28	14	137.30	1,215.24
900	10.37	101.70	150	1,327.68	15.30	15	147.11	1,302.00
960	11.06	108.48	160	1,416.24	16.32	16	156.91	1,388.88
1,020	11.75	115.26	170	1,504.68	17.34	17	166.72	1,475.64
1,080	12.44	122.04	180	1,593.24	18.36	18	176.53	1,562.40
1,140	13.13	128.82	190	1,681.68	19.38	19	186.33	1,649.16
1,200	13.82	135.60	200	1,770.24	20.40	20	196.14	1,736.04
1,260	14.51	142.38	210	1,858.80	21.42	21	205.95	1,822.80
1,320	15.20	149.16	220	1,947.24	22.44	22	215.75	1,909.56
1,380	15.89	155.94	230	2,035.80	23.46	23	225.37	1,996.44
1,440	16.58	162.72	240	2,124.24	24.48	24	235.37	2,083.20
1,500	17.28	169.50	250	2,212.80	25.50	25	245.18	2,170.08
1,560	17.97	176.28	260	2,301.36	26.52	26	254.98	2,256.96
1,620	18.66	183.06	270	2,389.80	27.54	27	264.79	2,343.60
1,680	19.35	189.84	280	2,478.36	28.56	28	274.60	2,430.48
1,740	20.04	196.62	290	2,566.92	29.58	29	284.41	2,517.24
1,800	20.73	203.40	300	2,655.48	30.60	30	294.22	2,604.00
1,860	21.42	210.18	310	2,744.04	31.62	31	304.03	2,690.76
1,920	22.11	216.96	320	2,832.60	32.64	32	313.84	2,777.52
1,980	22.80	223.74	330	2,921.16	33.66	33	323.65	2,864.28
2,040	23.49	230.52	340	3,009.72	34.68	34	333.46	2,951.04
2,100	24.19	237.30	350	3,099.60	35.70	35	343.35	3,036.60
2,160	24.88	244.08	360	3,188.16	36.72	36	353.16	3,123.36
2,220	25.57	250.86	370	3,276.72	37.74	37	362.97	3,210.12
2,280	26.26	257.64	380	3,365.28	38.76	38	372.78	3,296.88
2,340	26.95	264.42	390	3,453.84	39.78	39	382.59	3,383.64
2,400	27.64	271.20	400	3,542.40	40.80	40	392.40	3,470.40
2,460	28.33	277.98	410	3,630.96	41.82	41	402.21	3,557.16
2,520	29.02	284.76						
2,580	29.71	291.54						
2,640	30.40	298.32						
2,700	31.09	305.10						
2,760	31.78	311.88						
2,820	32.47	318.66						
2,880	33.16	325.44						
2,940	33.85	332.22						
3,000	34.54	339.00						
3,120	35.88	352.56						
3,240	37.26	366.12						
3,360	38.64	379.68						
3,480	40.02	393.24						
3,600	41.40	406.80						

CONVERSION FORMULAS

1 CMKG = 13.883 IN-OZ	1 dNm = 14.161 IN-OZ
1 CMKG = 0.8677 IN-LB	1 Nm = 8.8507 IN-LB
1 MKG = 7.233 FT-LB	1 Nm = 0.73756 FT-LB
1 CMKG = 1 CMKG	1 KpM = 1 MKG
1 FT-LB = 12 IN-LB	1 MKG = 9.80665 Nm

Purchased at: _____

Date: _____

ADJUSTMENT OF TORQUE SETTING

READ, UNDERSTAND AND FOLLOW ALL INSTRUCTIONS AND WARNINGS BEFORE OPERATING THIS TOOL. FAILURE TO DO SO MAY RESULT IN PERSONAL INJURY AND/OR PROPERTY DAMAGE AND WILL VOID WARRANTY.



HOW TO USE YOUR NEW TORQUE WRENCH

- Balancing wrench in hand with graduations visible unlock knurled handle by turning lock nut counter clockwise. (see fig. 1)
- Set amount of torque required by turning knurled handle to read exact amount on barrel graduations. Example: 145 in. lbs.
 - Turn knurled handle clockwise until the 0 in. lbs. graduation on the beveled edge of the handle is lined up with the vertical mark on the barrel and is even with the 140 in. lbs. graduations. (see fig. 2)
 - Continue turning handle clockwise until the 5 in. lbs. graduation on the beveled edge of the handle is in line with the vertical line on the barrel. (see fig. 3)
 - Lock knurled handle securely by turning lock nut clockwise. Wrench is now set at 145 in. lbs. and is ready to use.
- When setting for metric (Nm), use the same procedures as setting for in. lbs. using the Nm measurements on the opposite side of the barrel.
- Install the proper socket or attachment to the square drive and apply to nut or bolt and pull handle until you feel and/or here wrench click. Release, pull off and wrench automatically resets for the next operation.

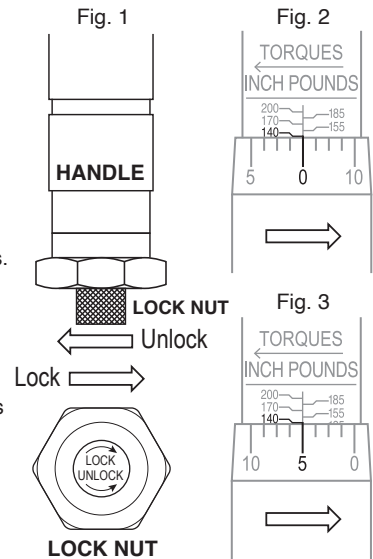

SAFETY GUIDELINES, WARNINGS AND PRECAUTIONS

CAUTION: DO NOT CONTINUE TO PULL AFTER WRENCH RELEASES. USE SPECIAL CARE AT LOW TORQUE SETTINGS THAT PULL STOPS WHEN WRENCH CLICKS.

- If wrench has not been used or has been in storage for some time, operate it several times at a low torque setting which permits special internal lubricants to recoat internal working parts

NOTE: When wrench is not in use, keep adjustment at lowest torque setting.

- Do not turn handle below lowest torque setting.
- Do not continue pulling on the wrench after pre-set torque has been reached and the wrench has released. Pressure must be taken off the handle and the wrench allowed to automatically reset itself. Continuing to apply pressure after the wrench has released, will result in damage to the part being torqued by applying more than the specified amount of torque.
- Tool is rugged and designed for shop use, but is also a precision measuring instrument and should be treated as such.
- Clean wrench by wiping with a cloth. Do not immerse in any type of cleaner which may affect special high pressure lube with which the wrench is packed at the factory.
- This torque wrench was calibrated and tested before leaving the factory and is accurate to $\pm 4\%$.

THIS IS A PRECISION MEASURING INSTRUMENT, CALIBRATION AND SERVICING MUST BE DONE REGULARLY AND IS THE OWNERS RESPONSIBILITY.