

STEP 6: GATES

Fig.9

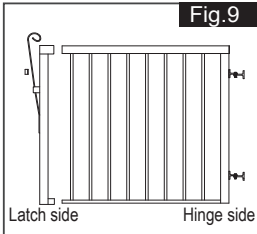

Cut down gate to meet the required width of your opening. Slide latch post on welded section; secure with provided fasteners. Secure hinges to post or wall with provided fasteners. Line up top of gate with top of deck railing and attach hinges with fasteners provided. Line up catch to latch and securing to post or wall with small Tek screws provided. (see Fig. 9)

UNIVERSAL ANGLE BRACKET

Fig.10

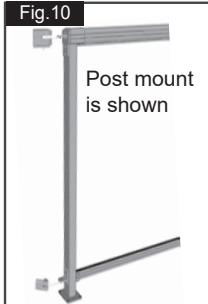

Vista™ Universal Angle Bracket can be used on its own for a wall connection or be attached onto a 2" or 2½" post. Due to different configuration options, it is especially important for UAB installation that the final glass sizes be taken after railing frame is installed. (see fig. 10)

NOTE: Does not work for a 90° angle.

Tools & Materials Required:

Handsaw 10" Miter Saw with thin (Kerf) Blade
Electric Drill - 1/8" and 3/16"
Drill Bits 3/8" Hex Head Driver
Torx Screwdriver - T25 drive
Robertson Screwdriver - #2
Measuring Tape
Rubber Mallet (optional)

vista
style &
simplicity

Residential Deck Railing Assembly Instructions

READ ALL INSTRUCTIONS COMPLETELY BEFORE STARTING INSTALLATION:

It is the responsibility of the installer to meet all code and safety requirements, and to obtain all required building permits. The railing installer should determine and implement appropriate installation techniques for each installation situation. VISTA Railing Systems Inc, its distributors and dealers shall not be held liable for improper or unsafe installations. VISTA Railing Systems posts must always be secured to the sub structure and should never be attached to only the surface material (ie deck board). Failure to follow all of these instructions could result in serious injury or death.

STEP 1: GETTING STARTED

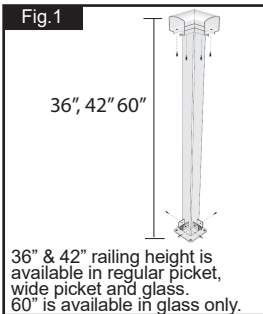

Locate posts as required with the bottom plate $\frac{1}{2}$ " from the edge of the deck (a greater distance from edge may be required on some decks so that post anchoring screws can attach to solid wood under deck surface).

STEP 2: POSTS



Install posts at this time with only 1 fastener (see Fig. 1, 2, and 3). This will allow enough movement in the post for installation of top rail later (see Step 3).

NOTE: Deck fasteners are not included.

STEP 3: LEVEL BRACKET ATTACHMENT

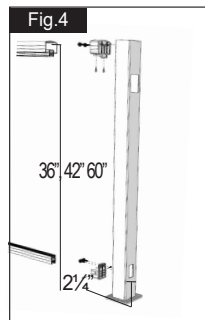

To locate the bottom bracket placement, measure up $2\frac{1}{4}$ " from deck surface to the bottom of bracket. Take a marker and mark the wall/post where the bracket screws will be placed. Attach bottom bracket to VISTA post.

To locate the top bracket placement, measure up 34" (for 36" height railings) or 40" (for 42" height railings) from deck to the bottom of the top bracket. Attach top bracket to VISTA post.

STEP 4: TOP RAIL ASSEMBLY

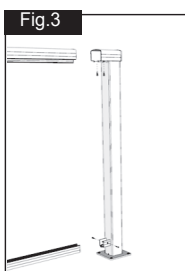

Measure distance between posts, deduct $\frac{1}{2}$ " and cut top rail section. **NOTE:** Top and bottom rail with clear picket gasket (**pre-installed**) can be cut at same time. We recommend drilling a $\frac{3}{16}$ " hole every 2 - 3 feet in bottom rail to allow water drainage. Install top rail securing one end only using #10 x $\frac{3}{4}$ " Tek screws provided with post. Check to ensure posts are perpendicular to deck surface, and install remainder of post to deck fasteners. Refer to step 2 for an appropriate method to attach posts and note about fasteners. (use exterior silicone "non-corrosive" caulking in screw holes for waterproofing). Secure other end of top rail. **For picket installation, go to Step 4A & 5. For glass installation, go to Step 5A.**

Important: Secure both ends using two of the #10 x $\frac{3}{4}$ " Tek screws provided, one from each side. (see Fig. 2, 3 and 4)

STEP 4A: BOTTOM RAIL ASSEMBLY

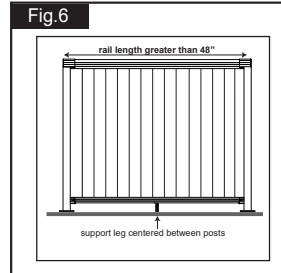

Install bottom rail with support leg in rough position (see Fig. 6). A bottom rail support leg should be used on spans greater than 48". Space bottom rail support leg evenly between posts and secure rails to post with supplied fasteners.

Important: Install supplied fasteners into pre-drilled holes on support leg to fastener to deck.

STEP 5: PICKET ASSEMBLY

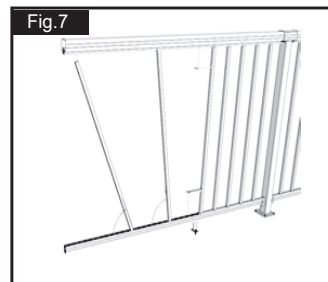

Starting at one end of a section, snap spacer over openings in top and bottom rails (use rubber mallet if necessary). Install picket as per Fig. 7 and repeat procedure until last 4 pickets are left. Install remaining pickets as a group (without spacers in between). Spread out and snap in remaining spacers.

NOTE: The last spacer will likely have to be cut to size. Picket spacing should not exceed 4".

STEP 5A: GLASS ASSEMBLY

Remove the pre-installed (clear picket gasket) and install the top gasket ('U-Shaped') into the top rail and the bottom gasket ('H-Shaped') into the bottom channel. Install bottom rail with support leg (if span is greater than 48") in rough position (see Fig 6). Measure to place in the middle and secure into the deck with #10 x $1\frac{1}{4}$ " wood screw (included). Fasten both top and bottom rails to posts using provided fasteners. When placing the glass panels into position, first place top edge of glass into the top rail gasket, then swing bottom edge of glass into bottom rail gasket and slide down firmly until it rests on the glass gasket (Fig 8).

Due to different configuration options, it is recommended that the final glass sizes be taken after railing frame is installed.

Recommended width of glass panel sizes should be approximately 2" less than the distance in between the posts (36" and 42" railing heights) for ease of installation. See Fig. 8A for Windwall recommendations. Glass thickness must be a minimum of $\frac{1}{4}$ " (6mm) and tempered as per local building code.

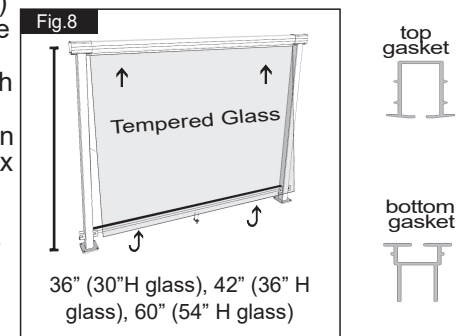

STEP 5B: WINDWALL ASSEMBLY

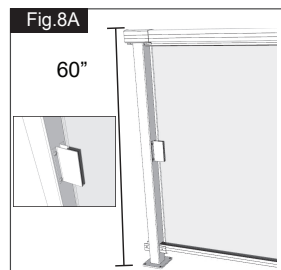

Attach foam pieces to brackets (included). Secure brackets to post with included fasteners. (see Fig 8A)

Note: 1" spacing on glass is recommended on the 60" Windwall system. In areas routinely exposed to wind gusts in excess of 60mph/100km, it may be necessary to consult a local design professional to determine whether this product is suitable for your application. It is required that the glass be supported mid span with a glass center support.