

# INSTRUCTION MANUAL

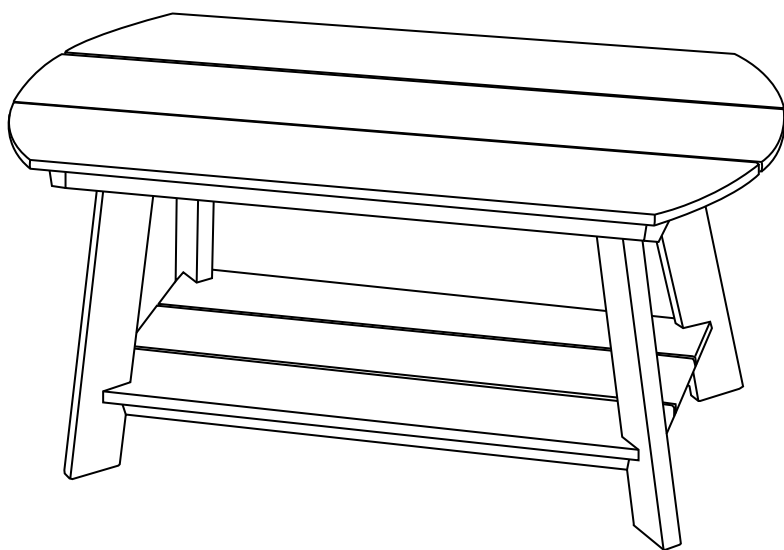

**Outdoor Adirondack Coffee Table**  
**SKU: OP8010**

**V1.0**

## ! CARE & MAINTENANCE

### Please keep this instruction for your future reference.

- Be careful when assembly, avoid hurting the table top surface.
- Clean the table with lukewarm water, mild detergent & soft cloth.
- Firmly secure all bolts before use, do not use any part of this item as a step ladder.
- Reconfirm that all bolts, screws, and nuts are secure every 90 days.
- Do not use or store this item in the proximity of open flame or flammable/combustible chemicals.
- Be aware that some parts are heavy and have sharp edges.
- Do not overtighten screws. (Insert all screws before tighten screws.)
- Please do not exceed the weight limitations of this item.

## TOOLS REQUIRED



ALLEN WRENCH  
(PROVIDED)



TABLE  
110 LBS  
CAPACITY



1 PERSON  
ASSEMBLY



UP TO 20 MIN.  
ASSEMBLY

## HARDWARE

1

M6 x 45mm  
BOLT



4 PCS

2

M6 x 55mm  
BOLT



4 PCS

3

FLANGE NUT



4 PCS

4

ALLEN  
WRENCH



1 PC

## PARTS

A

TABLE TOP  
WITH APRON

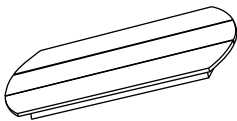

1 PC

B

BOTTOM PANEL  
WITH APRON

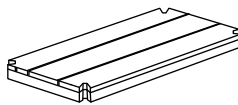

1 PC

C

TABLE LEG



4 PCS

## PRODUCT ASSEMBLY

1

Place Part A Table Top upside down on soft surface like carpet to avoid damage to the paint.

Attach 4 pcs of part C Table Legs to Table Top with 4 sets of hardware 2 Bolt and hardware 3 Nut.

Do not tighten bolts too much at this stage.

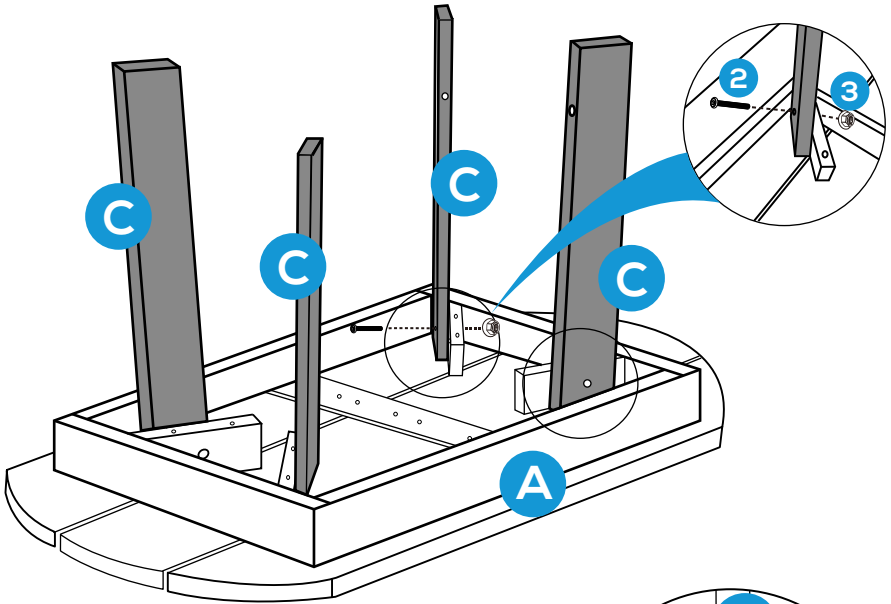

2

Attach part B Bottom Panel to part C Table Legs with 4 pcs of hardware 1 Bolt.

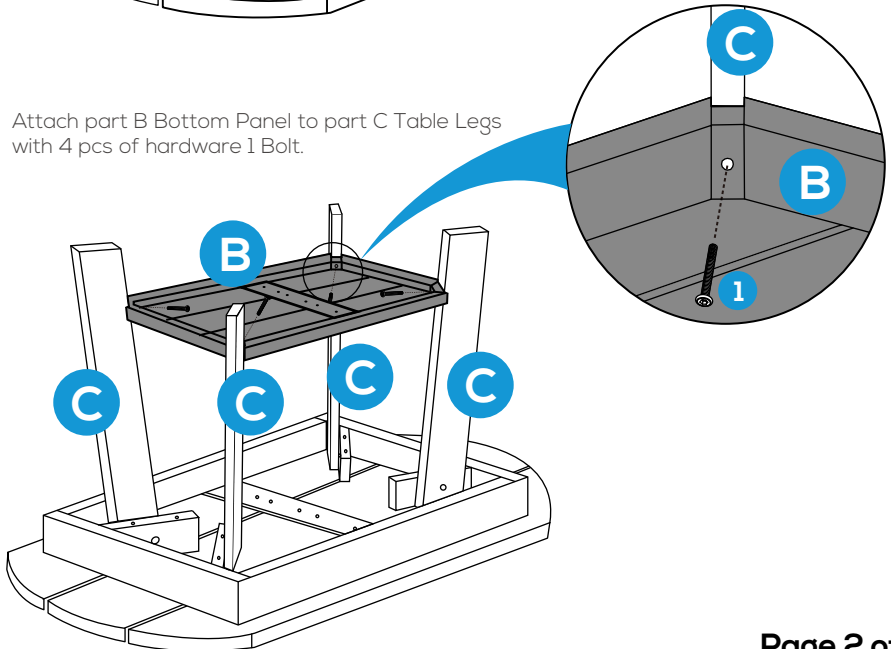

## PRODUCT ASSEMBLY

**3**

Tighten all the bolts again to ensure the steady of this table.

Place the table to normal position as below and finish the assembly.

